

Residential Infill Project

AN UPDATE TO PORTLAND'S
SINGLE-DWELLING ZONING RULES

REVISED PROPOSED DRAFT
FEBRUARY 2019

VOLUME 2: ZONING CODE AND COMPREHENSIVE PLAN AMENDMENTS



Bureau of Planning and Sustainability
Innovation. Collaboration. Practical Solutions.
City of Portland, Oregon



Table of Contents

Volume 2

Section 6: Zoning Code Amendments

33.110 Single-Dwelling Zones	5
33.205 Accessory Dwelling Units	131
33.251 Manufactured Homes and Manufactured Dwelling Parks	141
33.266 Parking, Loading, And Transportation And Parking Demand Management	143
33.270 Planned Development	155
33.281 Schools and School Sites	165
33.405 Additional Housing Opportunity Overlay Zone.....	169
33.418 Constrained Sites Overlay Zone	177
33.420 Design Overlay Zone	179
33.505 Albina Community Plan District	181
33.563 Northwest Hills Plan District	185
33.564 Pleasant Valley Plan District.....	187
33.610 Lots in RF through R5 Zones	189
33.611 Lots in the R2.5 Zone	193
33.676 Lot Confirmation	197
33.677 Property Line Adjustment.....	203
33.825 Design Review	211
33.854 Planned Development Review	213
33.900 List of Terms.....	219
33.910 Definitions.....	221
33.930 Measurements.....	229

Section 7: Comprehensive Plan Amendments

Chapter 10: Land Use Designations and Zoning	246
Glossary.....	250

About Volume 2

Volume 2 presents Zoning Code and Comprehensive Plan amendments to reflect the direction the Planning and Sustainability Commission provided staff following a series of work sessions between May and September 2018. These proposals include revisions to the previous Proposed Draft dated April 2018.

Section 6: Zoning Code Amendments

This document is formatted to facilitate readability by showing proposed amendments on the right-hand pages and explanatory commentary on the facing left-hand pages. Underlined formatting indicates added text, while ~~strikethrough~~ formatting shows what text is deleted. The table of contents provides page numbers for each affected chapter of the zoning code and the comprehensive plan amendments. The “crosswalk table” below is not an exhaustive list of all code changes, but rather it provides a cross reference between the core proposals in the Residential Infill Project and where those code changes appear in this document.

Major Proposals – where to find them in the Zoning Code amendments

Proposal	Summary of change	Code reference
HOUSING OPTIONS AND SCALE		
Allow more housing types	Allow duplex, triplex, or fourplex Allow a house with two ADUs, or a duplex with one ADU	33.110.265.D.& E. 33.205.020
Restrict housing types in certain situations	Unpaved streets Constrained sites	33.110.265.E 33.418
Limit the overall size of structures	New floor to area (FAR) standard Basements and floor area defined	33.110.210 33.910
Visitability	Require one unit to be visitable, when 3 or more units are on the site	33.110.265.E 33.205.040.C 33.270.200
Double-size lots	Require at least two units on oversized lots	33.110.205
Historically narrow lots	Allow historically narrow R5 lots to be confirmed	33.110.202
Small flag lots	Allow small flag lots to be created through property line adjustments	33.677.300.C
Planned developments	Equivalency with land divisions	33.270.020.B 33.854.200
BUILDING DESIGN		
Revise height measurement	Measure from lowest point Dormer projection	33.930.050 33.110.215.C
Building features and articulation	Limit height of main entrance 2’ eave projections	33.110.235.D 33.110.220.C.
More flexible ADU design	Basement ADU conversions Remove front door limitation	33.205.040.C.2 33.205.040.C.1
Modify parking requirements	Delete minimum parking requirements Alley access requirement Driveways and parking	33.266.110.B.2 33.266.120.C.3 33.266.120.C.1& 2
Limit garages	Garages on narrow facades/50% garage limit	33.110.250.C
Building design for lots less than 32 feet wide	Limit detached house height Require attached houses	33.110.260.C.2 33.110.260.C.1

Commentary

33.110 Single-Dwelling Zones

The chapter is being reorganized and renumbered.

The changes:

- Reorganize the order of sections so that general development standards are located toward the front of the chapter followed by additional standards, residential infill options, institutions, and fences and retaining walls
- Update table and figure references to reflect the order of appearance in the chapter
- Move the relevant parking and loading standards from the base zone into the Parking and Loading Chapter (33.266)
- Add a section for minimum dwelling unit density to address new development on double sized lots in the R7 through R2.5 zones (33.11.210)
- Add a new section for floor area ratios (33.110.210)
- Move flag lot provisions from Alternative Development Options into a new section titled Additional Development Standards for Flag Lots, (33.110.255)
- Reorganize and amend Alternative Development Options in a new section titled Residential Infill Options (33.110.265)
- Revise rules that previously applied to historically narrow lots and substandard lots created before July 26, 1979 to a new section titled Additional Development Standards for Narrow Lots" (33.110.260)

33.110 Single-Dwelling Zones

110

Sections:

General

- 33.110.010 Purpose
- 33.110.020 List of the Single-Dwelling Zones
- 33.110.030 Other Zoning Regulations

Use Regulations

- 33.110.100 Primary Uses
- 33.110.110 Accessory Uses
- ~~33.110.120 Nuisance-Related Impacts~~

Development Standards

- 33.110.200 Housing Types Allowed
- 33.110.~~202~~212 Development on Lots and Lots of Record ~~When Primary Structures are Allowed~~
- 33.110.205 Minimum Dwelling Unit Density
- 33.110.210 Floor Area Ratio
- 33.110.215 Height
- 33.110.220 Setbacks
- 33.110.225 Building Coverage
- 33.110.227 Trees
- 33.110.230 Main Entrances ~~in R10 through R2.5 Zones~~
- 33.110.~~235~~232 Street-Facing Facades ~~in R10 through R2.5 Zones~~
- 33.110.~~240~~235 Required Outdoor Areas
- ~~33.110.240 Alternative Development Options~~
- 33.110.~~245~~250 Detached and Connected Accessory Structures
- 33.110.~~250~~253 Additional Development Standards for Garages
- 33.110.255 Additional Development Standards for Flag Lots
- 33.110.~~260~~213 Additional Development Standards for Narrow Lots and Lots of Record
Created Before July 26, 1979
- 33.110.265 Residential Infill Options
- 33.110.~~270~~245 Institutional Development Standards
- 33.110.~~275~~255 Fences
- 33.110.~~280~~257 Retaining Walls
- 33.110.~~285~~260 Demolitions
- 33.110.~~290~~270 Nonconforming Situations Development
- 33.110.~~292~~275 Parking and Loading
- 33.110.~~295~~280 Signs

General

33.110.010 Purpose

The single-dwelling zones are intended to preserve land for housing and to provide housing opportunities for individual households. The zones implement the comprehensive plan policies and designations for single-dwelling housing and provide options for infill housing that is compatible with the scale of the single-dwelling neighborhood.

Commentary

- A. Use regulations.** The use regulations are intended to create, maintain and promote single-dwelling neighborhoods. They allow for some non-household living uses but not to such an extent as to sacrifice the overall image and character of the single-dwelling neighborhood.
- B. Development standards.** The development standards preserve the character of neighborhoods by providing six different zones with different densities and development standards. The development standards work together to promote desirable residential areas by addressing aesthetically pleasing environments, safety, privacy, energy conservation, and recreational opportunities. The site development standards allow for flexibility of development while maintaining compatibility within the City's various neighborhoods. In addition, the regulations provide certainty to property owners, developers, and neighbors about the limits of what is allowed. The development standards are generally written for houses on flat, regularly shaped lots. Other situations are addressed through special regulations or exceptions.

33.110.020 List of the Single-Dwelling Zones

The full names, short names, and map symbols of the single-dwelling residential zones are listed below. When this Title refers to the single-dwelling zones, it is referring to the six zones listed here. When this Title refers to the residential zones, or R zones, it is referring to both the single-dwelling zones in this chapter and the multi-dwelling zones in Chapter 33.120. The Residential Farm/Forest zone is intended to generally be an agricultural zone, but has been named Residential Farm/Forest to allow for ease of reference.

Full Name	Short Name/Map Symbol
Residential Farm/Forest	RF
Residential 20,000	R20
Residential 10,000	R10
Residential 7,000	R7
Residential 5,000	R5
Residential 2,500	R2.5

33.110.030 Other Zoning Regulations

The regulations in this chapter state the allowed uses and development standards for the base zones. Sites with overlay zones, plan districts, or designated historical landmarks are subject to additional regulations. The Official Zoning Maps indicate which sites are subject to these additional regulations. Specific uses or development types may also be subject to regulations in the 200s series of chapters.

Use Regulations

33.110.100 Primary Uses

- A. Allowed uses.** Uses allowed in the single-dwelling zones are listed in Table 110-1 with a "Y". These uses are allowed if they comply with the development standards and other regulations of this Title. Being listed as an allowed use does not mean that a proposed use will be granted an adjustment or other exception to the regulations of this Title. In addition, a use or development listed in the 200s series of chapters is also subject to the regulations of those chapters.

Commentary

33.110.100.B Limited uses

The Paragraphs in this subsection are being renumbered so that they align with the order that they appear in Table 110-1.

B. Limited uses. Uses allowed that are subject to limitations are listed in Table 110-1 with an "L". These uses are allowed if they comply with the limitations listed below and the development standards and other regulations of this Title. In addition, a use or development listed in the 200s series of chapters is also subject to the regulations of those chapters. The paragraphs listed below contain the limitations and correspond with the footnote numbers from Table 110-1.

~~140.~~ 140. Retail Sales ~~and~~ Service. This regulation applies to all parts of Table 110-1 that have note ~~[140]~~. Retail plant nurseries are a conditional use. All other Retail Sales And Service uses are prohibited.

~~26.~~ 26. Manufacturing And Production. This regulation applies to all parts of Table 110-1 that have note ~~[26]~~. Utility Scale Energy Production from large wind turbines is a conditional use in the RF zone. All other Manufacturing And Production uses are prohibited.

~~35.~~ 35. Basic Utilities. This regulation applies to all parts of Table 110-1 that have note ~~[35]~~.

- a. Basic Utilities that service a development site are accessory uses to the primary use being served.
- b. Small Scale Energy Production that provides energy for on-site or off-site use are considered accessory to the primary use on the site. Installations that sell power they generate—at retail (net, metered) or wholesale—are included. However, they are only considered accessory if they generate energy from biological materials or byproducts from the site itself, or conditions on the site itself; materials from other sites may not be used to generate energy. The requirements of Chapter 33.262, Off Site Impacts must be met.
- c. All other Basic Utilities are conditional uses.

~~41.~~ 41. Community Service Uses. This regulation applies to all parts of Table 110-1 that have note ~~[41]~~. Most Community Service uses are regulated by Chapter 33.815, Conditional Uses. Short term housing and mass shelters have additional regulations-in Chapter 33.285, Short Term Housing and Mass Shelters.

~~52.~~ 52. Parks And Open Areas. This regulation applies to all parts of Table 110-1 that have note ~~[52]~~. Parks And Open Areas uses are allowed by right. However, certain accessory uses and facilities ~~which that~~ are part of a Parks And Open Areas use require a conditional use review. These accessory uses and facilities are listed below.

- a. Swimming pools.
- b. Cemeteries, including mausoleums, chapels, and similar accessory structures associated with funerals or burial.
- c. Golf courses, including club houses, restaurants and driving ranges.
- d. Boat ramps.
- e. Parking areas.
- f. Recreational fields for organized sports. Recreational fields used for organized sports are subject to the regulations of Chapter 33.279, Recreational Fields for Organized Sports.

Commentary

33.110.100.B.8 Agriculture in R10 and R7 zones. This sentence is being added to make it consistent with other paragraphs.

33.110.100.B.9 Agriculture in R5 and R2.5 zones. The word "it" is being clarified because it could be referring to the use or the site.

33.110.100.C Conditional Uses

The reference for accessory short-term rentals that require a conditional use is being removed, as it is captured in the general language in 33.110.110 Accessory Uses. There are no proposed changes to the accessory short-term rental regulations.

- ~~63.~~ Daycare. This regulation applies to all parts of Table 110-1 that have note ~~[63]~~. Daycare uses are allowed by right if locating within a building ~~which~~that contains or contained a College, Medical Center, School, Religious Institution, or a Community Service use.
7. Agriculture in RF and R20 zones. This regulation applies to all parts of Table 110-1 that have note [7]. Agriculture is an allowed use. Where the use and site meet the regulations of Chapter 33.237, Food Production and Distribution, the applicant may choose whether it is allowed as a Market Garden.
8. Agriculture in R10 and R7 zones. This regulation applies to all parts of Table 110-1 that have note [8]. Agriculture is a conditional use. Where the use and site meet the regulations of Chapter 33.237, Food Production and Distribution, the applicant may choose whether it is allowed as a Market Garden, which does not require a conditional use.
9. Agriculture in R5 and R2.5 zones. This regulation applies to all parts of Table 110-1 that have note [9]. If the use and site do not meet the regulations of Chapter 33.237, Food Production and Distribution, ~~it~~Agriculture is prohibited.
104. Radio Frequency Transmission Facilities. This regulation applies to all parts of Table 110-1 that have note [104]. Some Radio Frequency Transmission Facilities are allowed by right. See Chapter 33.274.

C. Conditional uses. ~~1.~~—Table 110-1. Uses ~~which~~that are allowed if approved through the conditional use review process are listed in Table 110-1 with a "CU". These uses are allowed provided they comply with the conditional use approval criteria for that use, the development standards, and other regulations of this Title. Uses listed with a "CU" that also have a footnote number in the table are subject to the regulations cited in the footnote. In addition, a use or development listed in the 200s series of chapters is also subject to the regulations of those chapters. The conditional use review process and approval criteria are stated in Chapter 33.815, Conditional Uses.

~~2.~~—~~Accessory short term rentals. Accessory short term rentals are accessory uses that may require a conditional use review. See Chapter 33.207.~~

D. Prohibited uses. Uses listed in Table 110-1 with an "N" are prohibited. Existing uses in categories listed as prohibited may be subject to the regulations of Chapter 33.258, Nonconforming Uses And Development.

33.110.110 Accessory Uses

Accessory uses to a primary use are allowed if they comply with all development standards. Accessory home occupations, accessory dwelling units, and accessory short-term rentals have specific regulations in Chapters 33.203, 33.205, and 33.207 respectively.

Commentary

33.110.120 Nuisance-Related Impacts

References that are not regulatory and only refer to other titles of City code are being removed.

Table 110-1

Numbers in Table 110-1 are being reordered to reflect the order that they appear in the table (and correspond to the revisions to the previous notes in 33.110.100).

33.110.120 Nuisance-Related Impacts

- A. ~~Off-site impacts.~~** All nonresidential primary and accessory uses must comply with the standards of Chapter ~~33.262, Off-Site Impacts.~~
- B. ~~Vehicles.~~** The regulations for operable vehicles and for vehicle service and repair are stated in ~~33.266.150, Vehicles in Residential Zones.~~ The open accumulation and storage of inoperable, neglected, or discarded vehicles is regulated by Section ~~29.20.010 of Title 29, Property and Maintenance Regulations.~~
- C. ~~Animals.~~** Nuisance-type impacts related to animals are regulated by Title 13, Animals. Title 13 is enforced by the County Health Officer.
- D. ~~Other nuisances.~~** Other nuisances are regulated by Section ~~29.20.010 of Title 29, Property and Maintenance Regulations.~~

Table 110-1 Single-Dwelling Zone Primary Uses						
Use Categories	RF	R20	R10	R7	R5	R2.5
Residential Categories						
Household Living	Y	Y	Y	Y	Y	Y
Group Living	CU	CU	CU	CU	CU	CU
Commercial Categories						
Retail Sales And Service	CU <u>[110]</u>	CU <u>[110]</u>	CU <u>[110]</u>	CU <u>[110]</u>	CU <u>[110]</u>	CU <u>[110]</u>
Office	N	N	N	N	N	N
Quick Vehicle Servicing	N	N	N	N	N	N
Vehicle Repair	N	N	N	N	N	N
Commercial Parking	N	N	N	N	N	N
Self-Service Storage	N	N	N	N	N	N
Commercial Outdoor Recreation	N	N	N	N	N	N
Major Event Entertainment	N	N	N	N	N	N
Industrial Categories						
Manufacturing And Production	CU <u>[26]</u>	N	N	N	N	N
Warehouse And Freight Movement	N	N	N	N	N	N
Wholesale Sales	N	N	N	N	N	N
Industrial Service	N	N	N	N	N	N
Bulk Fossil Fuel Terminal	N	N	N	N	N	N
Railroad Yards	N	N	N	N	N	N
Waste-Related	N	N	N	N	N	N

Commentary

Table 110-1

Footnote numbers are being updated to be in numerical order

Language to be **added** is underlined
 Language to be **deleted** is shown in ~~strikethrough~~

Table 110-1 Single-Dwelling Zone Primary Uses						
Use Categories	RF	R20	R10	R7	R5	R2.5
Institutional Categories						
Basic Utilities	<u>L/CU [35]</u>	<u>L/CU [35]</u>	<u>L/CU [35]</u>	<u>L/CU [35]</u>	<u>L/CU [35]</u>	<u>L/CU [35]</u>
Community Service	<u>L/CU [41]</u>	<u>L/CU [41]</u>	<u>L/CU [41]</u>	<u>L/CU [41]</u>	<u>L/CU [41]</u>	<u>L/CU [41]</u>
Parks And Open Areas	<u>L/CU [52]</u>	<u>L/CU [52]</u>	<u>L/CU [52]</u>	<u>L/CU [52]</u>	<u>L/CU [52]</u>	<u>L/CU [52]</u>
Schools	CU	CU	CU	CU	CU	CU
Colleges	CU	CU	CU	CU	CU	CU
Medical Centers	CU	CU	CU	CU	CU	CU
Religious Institutions	CU	CU	CU	CU	CU	CU
Daycare	<u>L/CU [63]</u>	<u>L/CU [63]</u>	<u>L/CU [63]</u>	<u>L/CU [63]</u>	<u>L/CU [63]</u>	<u>L/CU [63]</u>
Other Categories						
Agriculture	L [7]	L [7]	<u>L/CU [8]</u>	<u>L/CU [8]</u>	L [9]	L [9]
Aviation And Surface Passenger Terminals	CU	N	N	N	N	N
Detention Facilities	N	N	N	N	N	N
Mining	CU	N	N	N	N	N
Radio Frequency Transmission Facilities	<u>L/CU [104]</u>	<u>L/CU [104]</u>	<u>L/CU [104]</u>	<u>L/CU [104]</u>	<u>L/CU [104]</u>	<u>L/CU [104]</u>
Railroad Lines And Utility Corridors	CU	CU	CU	CU	CU	CU

Y = Yes, Allowed

L = Allowed, But Special Limitations

CU = Conditional Use Review Required

N = No, Prohibited

Notes:

- The use categories are described in Chapter 33.920.
- Regulations that correspond to the bracketed numbers [] are stated in 33.110.100.B.
- Specific uses and developments may also be subject to regulations in the 200s series of chapters.

Commentary

Table 110-2

The reference to duplexes and attached houses on transitional lots is being deleted from the table because the transitional lot alternative development option is being deleted (see page 67 for further discussion).

References to triplexes and fourplexes are being added because those housing types will be allowed as described in 33.110.265, Residential Infill Options (see page 113)

A reference to multi-dwelling development is being added to the table because the housing type is currently allowed in single dwelling zones through a planned development but the table has not included the reference.

The term group structure is being corrected to match the actual name of the residential structure type—group living facility.

Development Standards

33.110.200 Housing Types Allowed

- A. Purpose.** Housing types are limited in the single-dwelling zones to maintain the overall image and character of the City's single-dwelling neighborhoods. However, the regulations allow options to increase housing variety and opportunities, and to promote affordable and energy-efficient housing.
- B. Housing types.** The kinds of housing types allowed in the single-dwelling zones are stated in Table 110-2.

Table 110-2 Housing Types Allowed In The Single-Dwelling Zones						
Housing Type	RF	R20	R10	R7	R5	R2.5
House	Yes	Yes	Yes	Yes	Yes	Yes
Attached house (See <u>33.110.260.C</u> and <u>33.110.240270.C, E & H</u>)	No	Yes	Yes	Yes	Yes	Yes
Accessory dwelling unit (See 33.205)	Yes	Yes	Yes	Yes	Yes	Yes
Duplexes: On corners (See <u>33.110.240270.D-E</u>)	No	Yes	Yes	Yes	Yes	Yes
On transitional lots (See <u>33.110.240.H</u>)	No	Yes	Yes	Yes	Yes	Yes
Other situations (See <u>33.110.240270.D</u>)	No	No	No	No <u>Yes</u>	No <u>Yes</u>	Yes
<u>Triplexes</u> (See <u>33.110.265.E</u>)	<u>No</u>	<u>No</u>	<u>No</u>	<u>Yes</u>	<u>Yes</u>	<u>Yes</u>
<u>Fourplexes</u> (See <u>33.110.265.E</u>)	<u>No</u>	<u>No</u>	<u>No</u>	<u>Yes</u>	<u>Yes</u>	<u>Yes</u>
Manufactured home (See Chapter 33.251)	Yes	Yes	Yes	Yes	Yes	Yes
Manufactured Dwelling park	No	No	No	No	No	No
Houseboat (See Chapter 33.236)	Yes	Yes	Yes	Yes	Yes	Yes
Single Room Occupancy (SRO) units	No	No	No	No	No	No
Attached Duplexes	Only in Planned Developments, See Chapter 33.270.					
Group <u>Living Facility structure</u>	Only when in conjunction with an approved conditional use.					
Multi-dwelling structure	Only in Planned Developments, See Chapter 33.270					
<u>Multi-dwelling development</u>	<u>Only in Planned Developments, See Chapter 33.270</u>					

Yes = allowed; No = prohibited.

Commentary

33.110.202 Development on Lots and Lots of Record

Paragraph 4 is being reorganized to consolidate a number of similar provisions and to incorporate information that had been in footnotes to the table.

The information in 4.d. is being moved from the table footnotes to the text of the subparagraph, and will continue to allow lots (including lot remnants, adjusted lots, and lots of record) that were lawfully established prior to July 26, 1979, and under separate ownership on April 24, 2010, to be buildable. This subparagraph also recognized as buildable, lots that would otherwise be too small for development but complete a lot confirmation under the existing regulations within 6 months of the effective date of these code amendments.

33.110.202212 Development on Lots and Lots of Record~~When Primary Structures are Allowed~~

- A. Purpose.** The regulations of this section allow for development of primary structures on lots and lots of record that are an adequate size, but do not legitimize plots that were divided after subdivision and partitioning regulations were established. The regulations ensure that development on a site will in most cases be able to comply with all site development standards. The regulations also allow development of primary structures on lots that were large enough in the past, but were reduced by condemnation or required dedications for right-of-way.
- B. Adjustments.** Adjustments to this section are prohibited.
- C. Development on lots and lots of record**~~Primary structures allowed.~~ In all areas outside the West Portland Park Subdivision, development of primary structures are is allowed on a lot or lot of record as follows:
1. On a lots created on or after July 26, 1979;
 2. On a lots created through the Planned Development or Planned Unit Development process;
 3. On a lots, lots of record, lot remnants, or combinations thereof that did not abut~~have not abutted~~ a lot, lot of record, or lot remnant under the same ownership on July 26, 1979, and has not abutted a lot, lot of record, or lot remnant under the same ownership since July 26, 1979; or any time since that date.
 4. On a lots, lots of record, lot remnants, or combinations thereof created before July 26, 1979 that: ~~meet the requirements of Table 110-6.~~
 - a. Meets the requirements of Table 110-3;
 - b. Did meet the requirements of Table 110-3 but was reduced below the requirements solely because of condemnation or required dedication by a public agency for right-of-way;
 - c. Is zoned R20 and met the requirements of Table 110-3 in the past but no longer meets the requirements solely due to a zone change effective on May 24, 2018; or
 - d. Does not meet the requirements of Table 110-3 but:
 - (1) Is zoned R5 and was under separate ownership from abutting lots on April 24, 2010; or
 - (2) Was separated from abutting lots through a lot confirmation that was finalized before [INSERT EFFECTIVE DATE + 6 MONTHS]

Commentary

33.110.202.E.3.c.

This amendment adds R10 to the lot regulations for the West Portland Park subdivision. There are two small areas of R10 zoning in West Portland Park, and currently a lot in R10 only needs to be 6,000 square feet in area to be buildable, but a lot in R7 must be 7,000 square feet in size to be buildable. This change corrects that inconsistency.

33.110.202.F. Nonconforming situations.

This subsection is being deleted because it does not provide any regulations and there is another section in this chapter directs people to the nonconforming situations chapter (33.110.290).

- ~~5. Primary structures are allowed on lots, lots of record, lot remnants, and combinations thereof that did meet the requirements of Table 110-6 in the past but were reduced below those requirements solely because of condemnation or required dedication by a public agency for right-of-way; or.~~
- ~~6. On lots, lots of record, lot remnants, and combinations thereof zoned R20 that met the requirements of Table 110-6 in the past but no longer meet the requirements solely due to a zone change effective on January 1, 2018.~~

D. ~~Regulations for~~ Development on lots and lots of record in West Portland Park. In the West Portland Park subdivision, development of primary structures are ~~is~~ allowed on a lot or lot of record as follows:

1. On a ~~lots~~ created on or after July 26, 1979;
2. On a ~~lots, lots of record, lot remnants, or combinations thereof that did not abut~~ ~~have not abutted~~ a lot, lot of record, or lot remnant under the same ownership on July 26, 1979, and has not abutted a lot, lot of record, or lot remnant under the same ownership since July 26, 1979; or any time since that date;
3. On a ~~lots, lots of record, lot remnants, or combinations thereof created before July 26, 1979, that meet the requirements of this paragraph. The requirements are:~~
 - a. R10 zone. In the R10 zone, the lot, lot of record, lot remnant or combinations thereof must be at least 10,000 square feet in area;
 - ba. R7 zone. In the R7 zone, the lot, lot of record, lot remnant or combinations thereof must be at least 7,000 square feet in area;
 - cb. R5 zone. In the R5 zone, the lot, lot of record, lot remnant or combinations thereof must be at least 5,000 square feet in area; or
 - de. R2.5 zone. In the R2.5 zone, the lot, lot of record, lot remnant or combinations thereof must meet the requirements of Table 110-36.;
4. Development of P ~~primary structures are~~ is ~~allowed on~~ a ~~lots, lots of record, lot remnants and/or combinations thereof that did meet the requirements of D.2, above, in the past but were~~ ~~was~~ reduced below those requirements solely because of condemnation or required dedication by a public agency for right-of-way.

~~FE.~~ Plots. Primary structures are prohibited on plots that are not lots, lots of record, lot remnants, or tracts.

~~F.~~ Nonconforming situations. Existing development and residential densities that do not conform to the requirements of this chapter may be subject to the regulations of Chapter 33.258, Nonconforming Situations. Chapter 33.258 also includes regulations regarding damage to or destruction of nonconforming situations.

Commentary

Table 110-3

In the R5 zone, the previous standard that required a lot be vacant for 5 years if it was less than 36 feet wide or 3,000 square feet is being deleted. Since pairs of these lots will now allow duplexes to be built, allowing lots to be independently built with attached houses achieves a similar form with fee simple ownership potential.

The property line adjustment regulations are also being changed so that combination Lot Confirmation/Property Line Adjustments cannot occur concurrently to make a buildable lot from a lot that is not independently already "buildable" (33.677). These regulations also restrict lots that are narrower than required in the land division chapters (33.610 and 33.611) from having their width further reduced. Lots that were adjusted prior to these changes will continue to be allowed to be built when they are at least 25' feet wide and 2,400 square feet.

Footnote [2] is being added to recognize that the property line adjustment chapter includes provisions to allow the lot line between 2 long narrow lots on a corner to be "swiveled" to create 2 square shaped lots. In addition, the PLA chapter will allow creation of a small flag lot when retaining an existing house on the site.

Note [1] is being deleted because the standards for lots and adjusted lots are now the same.

Note [2] is being deleted because this provision relates to sites that had a dwelling unit on it in the last 5 years. This provision is no longer a relevant threshold for confirming a lot.

Note [3] is being deleted because the updated standards are now embedded in 33.110.202.C

Note [4] is renumbered.

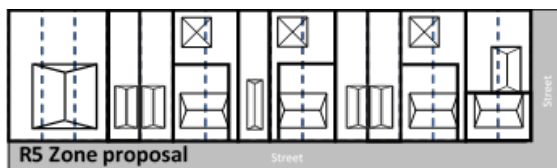
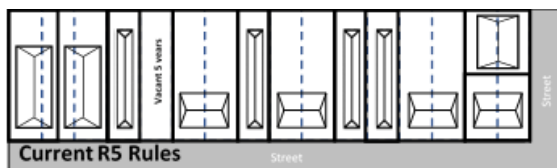
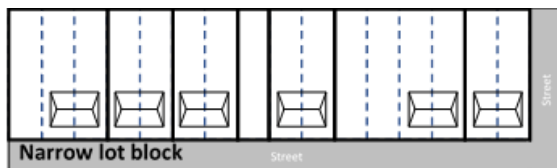

Language to be **added** is underlined
 Language to be **deleted** is shown in ~~strikethrough~~

Table 110-36		
Minimum Lot Dimension Standards for Lots, Adjusted Lots, Lots of Record, and Lot Remnants Created Prior to July 26, 1979		
RF through R7 Zones		
Lots, including Adjusted Lots {1}	36 feet wide and meets the minimum lot area requirement of Table 610-2. <u>[14]</u>	
Lot Remnants		
Lots of Record		
R5 Zone		
Lots, including Adjusted Lots {1, 3}	If the lot has had a dwelling unit on it in the last five years or is in an environmental zone {2}	3000 sq. ft. and 36 ft. wide <u>[14]</u>
	If the lot has not had a dwelling unit on it within the last five years and is not in an environmental zone	2400 sq. ft. and 25 ft. wide <u>[1, 24]</u>
	If the lot was approved through a property line adjustment under 33.667.300.A.1.d.	1600 sq. ft. and 36 ft. wide {4}
Lot Remnants {3}	3000 sq. ft. and 36 ft. wide <u>[14]</u>	
Lots of Record {1, 3}		
R2.5 Zone		
Lots, including Adjusted Lots {1}	1600 sq. ft.	
Lot Remnants		
Lots of Record		

Notes:

- ~~[1] If the property is both an adjusted lot and a lot of record, the site may meet the standards for adjusted lots.~~
- ~~[2] Primary structures are allowed if the site has had a dwelling unit on it within the last five years that has been demolished as a public nuisance under the provisions of Chapter 29.40.030 or 29.60.080. The site is exempt from minimum lot dimension standards.~~
- ~~[3] Primary structures are allowed on a site if it has been under a separate tax account number from abutting lots or lots of record on April 24, 2010 or an application was filed with the City before April 24, 2010 authorizing a separate tax account and the site has been under separate tax account from abutting lots or lots of record by April 24, 2011. The site is exempt from minimum lot dimension standards.~~
- [14] Lot width for a flag lot is measured at the midpoint of the flag portion of the lot.
- [2] If the lot was approved through a property line adjustment under 33.677.300.A.4. or 33.677.300.C. then the minimum lot dimensions are 1600 sq. ft. and 36 ft wide.

Commentary

33.110.205 Minimum Dwelling Unit Density

In order to ensure that lots are not underutilized in close-in, well-served neighborhoods, sites in the R7, R5, and R2.5 zones that are at least twice the base zone average lot size will require two dwelling units. The dwelling units can be configured as a duplex or a house with accessory dwelling unit. Existing houses on these larger lots will become nonconforming in residential density, but if an existing house is damaged or destroyed by fire or other natural cause, it can be rebuilt at the original density within 5 years. New primary structures on sites that are vacant, or where a house is intentionally demolished, will be required to provide two dwelling units.

33.110.205 Minimum Dwelling Unit Density

A. Purpose. This standard promotes additional housing opportunities in areas of the city where services are available and restricts larger sites from being utilized for a single house.

B. Minimum dwelling unit density.

1. R7. In the R7 zone, a minimum of two dwelling units are required on sites that are 14,000 square feet or larger in total site area.
2. R5. In the R5 zone, a minimum of two dwelling units are required on sites that are 10,000 square feet or larger in total site area.
3. R2.5. In the R2.5 zone, a minimum of two dwelling units are required on sites that are 5,000 square feet or larger in total site area.

Commentary

Table 110-4

This table is being amended to include the floor area ratio (FAR) limits that are being added to the R7, R5, and R2.5 zones. FAR will be as the principle tool for reducing the maximum size of buildings in these zones. FAR will be allotted based on the zone, the size of the lot and the number of dwelling units. The table below shows housing types and the maximum FAR allowed across the three zones. Bonus FAR (0.1 :1)) will be allowed when certain amenities are provided on site (see page 29)

R7 Zone	# of units	Allowed housing type	FAR	Min lot size (sf)	New max bldg size	average unit size*	Current code max bldg. size**
	1	House	0.4	4,200	1,680	1680	5,850
2	Duplex <i>or</i> house + ADU	0.5		2100	1050		
3	Triplex <i>or</i> duplex + ADU <i>or</i> house + 2 ADUs	0.6	5,000	3,000	1000	6,750	
4	Fourplex				750		
R5 Zone	# of units	Allowed housing type	FAR	Min lot size (sf)	New max bldg size	average unit size*	Current code max bldg. size**
	1	House	0.5	3,000	1,500	1500	4,500
2	Duplex <i>or</i> house + ADU	0.6		1800	900		
3	Triplex <i>or</i> duplex + ADU <i>or</i> house + 2 ADUs	0.7	4,500	3,150	1050	6,187	
4	Fourplex				787.5		
R2.5 Zone	# of units	Allowed housing type	FAR	Min lot size (sf)	New max bldg size	average unit size*	Current code max bldg. size**
	1	House	0.7		1,120	1120	2,800
2	Duplex <i>or</i> house + ADU	0.8	1,600	1280	640		
3	Triplex <i>or</i> duplex + ADU <i>or</i> house + 2 ADUs	0.9	3,200	2,880	960	5,512	
4	Fourplex				720		

* average unit sizes are derived from the total building size divided by number of units

** Current code max building sizes are derived from lot size, building coverage and height limits

The table is also being amended to consolidate the R2.5 attached and detached standards because the only remaining distinction between the two housing types within the zone is a slightly smaller outdoor area. This change will decrease the outdoor area requirement for detached houses.

And, a reference to the building coverage table is being incorporated into the summary table so that the table is more comprehensive.

Language to be **added** is underlined
 Language to be **deleted** is shown in ~~strikethrough~~

Table 110-43							
Summary of Development Standards In Single-Dwelling Zones							
Standard	RF	R20	R10	R7	R5	R2.5 detached attached See 33.110.240.C	
<u>Maximum FAR</u> - <u>1 total dwelling unit</u> - <u>2 total dwelling units [1]</u> - <u>3 or more total dwelling units [1]</u> (See <u>33.110.210</u> and <u>33.110.265</u>)	no limit	no limit	no limit	<u>0.4 to 1</u> <u>0.5 to 1</u> <u>0.6 to 1</u>	<u>0.5 to 1</u> <u>0.6 to 1</u> <u>0.7 to 1</u>		<u>0.7 to 1</u> <u>0.8 to 1</u> <u>0.9 to 1</u>
<u>Maximum FAR with Bonus</u> - <u>1 total dwelling unit</u> - <u>2 total dwelling units [1]</u> - <u>3 or more total dwelling units [1]</u> (See <u>33.110.210</u> and <u>33.110.265</u>)	NA	NA	NA	<u>0.4 to 1</u> <u>0.6 to 1</u> <u>0.7 to 1</u>	<u>0.5 to 1</u> <u>0.7 to 1</u> <u>0.8 to 1</u>		<u>0.7 to 1</u> <u>0.9 to 1</u> <u>1 to 1</u>
Maximum Height (See 33.110.215)	30 ft.	30 ft.	30 ft.	30 ft.	30 ft.	35 ft.	35 ft.
Minimum Setbacks							
- Front building setback	20 ft.	20 ft.	20 ft.	15 ft.	10 ft.	10 ft.	10 ft.
- Side building setback	10 ft.	10 ft.	10 ft.	5 ft.	5 ft.	5 ft.	0/5 ft.
- Rear building setback	10 ft.	10 ft.	10 ft.	5 ft.	5 ft.	5 ft.	5 ft.
- Garage entrance setback (See 33.110.220)	18 ft.	18 ft.	18 ft.	18 ft.	18 ft.	18 ft.	18 ft.
<u>Maximum Building Coverage</u> (See <u>33.110.225</u>)	<u>See Table 110-6</u>	<u>See Table 110-6</u>	<u>See Table 110-6</u>	<u>See Table 110-6</u>	<u>See Table 110-6</u>		<u>See Table 110-6</u>
Required Outdoor Area							
- Minimum area	250 sq. ft.	250 sq. ft.	250 sq. ft.	250 sq. ft.	250 sq. ft.	250 sq. ft.	200 sq. ft.
- Minimum dimension (See <u>33.110.240</u> 235)	12 ft. x 12 ft.	12 ft. x 12 ft.	12 ft. x 12 ft.	12 ft. x 12 ft.	12 ft. x 12 ft.	12 ft. x 12 ft.	10 ft. x 10 ft.

Commentary

33.110.210 Floor Area Ratios

FAR limits are being added to the R7, R5 and R2.5 zones. Over the last few years, new houses in these zones have grown in size to the point where new development sometimes overwhelms existing houses on the block. With the potential for additional ADUs and dwelling units (up to four units per lot in some cases), there could be pressure to continue to increase the size of buildings.

FAR is an effective tool for regulating the overall bulk of a building while providing reasonable flexibility in site layout, housing style and design. Buildings with more floors will have smaller footprints, which increase outdoor area and yard space, but more floors can increase shadowing and reduce privacy on adjacent lots. Buildings that are single level can have larger footprints that reduce yard space, however this configuration can improve privacy for adjacent lots. The proposed FARs were calculated with consideration of building coverage limits to encourage smaller building footprints and larger outdoor areas. The proposed FARs also encourage compatibility with adjacent existing houses.

FAR limits are not proposed for the lowest density zones (RF, R20, R10), because these areas are characterized by larger and more variable lot sizes. Consequently, new development in these areas has not generally overwhelmed adjacent lots. In addition, the additional housing types allowed in R7-R2.5 will not be allowed in RF-R10, which lessens pressure for building larger structures.

Floor area in basements and attics where the ceiling height is less than 80 inches will not count toward FAR because these spaces do not contribute significantly to visible building bulk (see the amended definition of Floor Area and Basement on pages 221 and 223).

Adjustments to FAR will be prohibited. Additional FAR will be allowed by retaining and converting an existing house, and by providing an affordable unit. Allowing adjustment to maximum FAR would undermine this system of incentives.

33.110.210.C

Bonus FAR (up to 0.1 total) may be gained when either:

- one unit is made available to those earning up to 80% of the area median income; or
- additional units (up to a maximum of four) are added to a site with an existing residential structure. The existing residential structure can be converted to add units or ADUs can be added to the site.

This additional FAR is not additive, meaning these two provisions cannot be combined for even more FAR.

33.110.210 Floor Area Ratios

- A. Purpose.** Floor area ratios (FAR) in the R7, R5 and R2.5 zones work with height, setback, and building coverage requirements to control the overall bulk and placement of buildings. The maximum FAR allowances have been calibrated by zone to:
- Define the character of each zone by establishing greater FAR allowances in the higher intensity zones;
 - Encourage the provision of additional dwelling units within existing neighborhoods by relating the allowed amount of FAR to the total number of units on a site; and
 - Ensure that the bulk of buildings on one lot does not overwhelm development on adjacent lots.
- B. Maximum FAR.** Maximum floor area ratios are stated in Table 110-5. The maximum FAR allowed is based on the total number of dwelling units on the site and whether a bonus option is chosen. The maximum FAR for institutional uses is stated in 33.110.270. Adjustments to the maximum FAR ratios, including bonus ratios, are prohibited.
- C. Maximum FAR with bonus.**
1. Affordable housing bonus option. In the R7, R5 and R2.5 zones, the maximum FAR for sites that provide at least one dwelling unit to those earning no more than 80 percent of the area median family income is stated in Table 110-5. To qualify for this maximum FAR with bonus:
 - a. The applicant must provide a letter from the Portland Housing Bureau certifying that the development meets the affordability standard stated above. The letter is required to be submitted before a building permit can be issued but is not required in order to apply for a land use review; and
 - b. The property owner must execute a covenant with the City that complies with the requirements of 33.700.060. The covenant must ensure that the affordable dwelling unit will remain affordable to households meeting the income restriction and any administrative requirements of the Portland Housing Bureau.
 2. Preserving existing dwelling units bonus option. In the R7, R5 and R2.5 zones, the maximum FAR for sites that contain a primary residential structure that received final inspection at least 5 years ago is stated in Table 110-5. To qualify for this maximum FAR with bonus, no more than 25 percent of the existing street-facing façade of the primary residential structure may be altered to add additional floor area.

Commentary

33.110.215.B.2. Exceptions

The height for narrow lots have been consolidated and amended in a section—33.110.260, Additional Development Standards for Narrow Lots

33.110.215 Height

- A. Purpose.** The height standards serve several purposes:
- They ~~promote~~foster a reasonable building scale and relationship of one residence to another;
 - They promote options for privacy for neighboring properties; and
 - They reflect the general building scale and placement of houses in the city's single-dwelling neighborhoods.
- B. Maximum height.** ~~1.—Generally. The maximum height allowed for all structures is stated in Table 110-4-3. The maximum height standard for institutional uses is stated in 33.110.245, Institutional Development Standards. The maximum height standards for detached and~~ and connected accessory structures are stated in 33.110.245~~250~~, Detached and Connected Accessory Structures. The maximum height standard for narrow lots is stated in 33.110.260, Additional Development Standards for Narrow Lots. The maximum height standard for small flag lots is stated in 33.110.255, Additional Standards for Flag Lots. The maximum height standard for Institutional uses is stated in 33.110.270, Institutional Development Standards.
- ~~2.—Exceptions.~~
- a.—~~R10-R5 zones. The maximum height for all primary structures on new narrow lots in the R10 to R5 zones is 1.2 times the width of the structure, up to the maximum height limit listed in Table 110-3; and~~
- b.—~~R2.5 zone. The maximum height for all primary structures on new narrow lots in the R2.5 zone is 1.5 times the width of the new structure, up to the maximum height limit listed in Table 110-3.~~
- ~~For the purposes of this Paragraph, width is the length of the street-facing facade of the dwelling unit. See Figure 110-1. Modifications are allowed through Planned Development Review, see Chapter 33.638, Planned Development. Adjustments to this paragraph are prohibited.~~

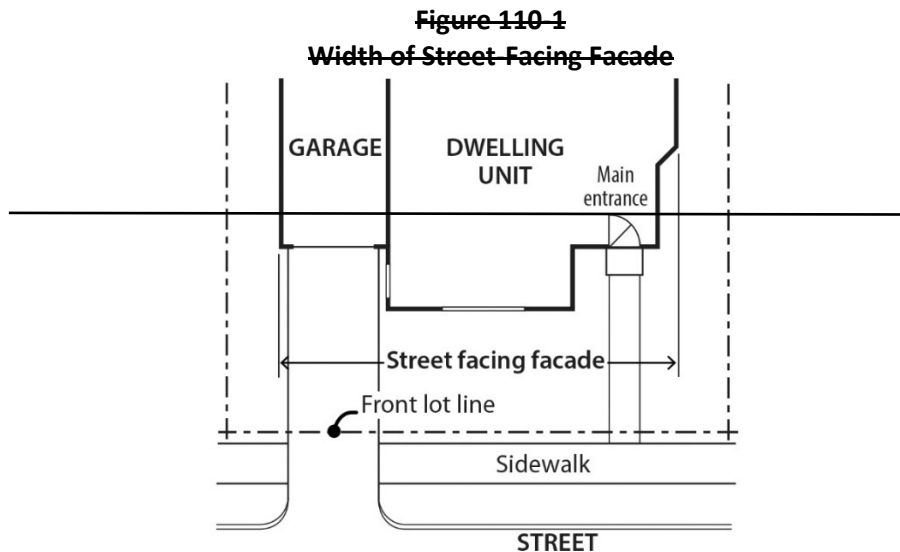

Commentary

33.110.215.C. Exceptions to Maximum Height.

Currently, the midpoint of the highest gable on a gable roof is used to measure height. Dormers have been used to extend a full floor above the height limit, as long as the ridge of the dormer is below the top of the gable, making it not the "highest gable" (see drawing below). Amendments to the method of measuring height (see Chapter 33.930 Measurements) identifies the "top" of a building as the roof that yields the highest reference point. On a house with a dormer, the shed roof of the dormer would be measured to the highest point (the apex of the dormer shed roof).

This exception is intended to allow dormer projections but constrain them so that they remain a secondary roof mass, and not an extension of the entire floor as a way of circumventing the height limit (see comparison below). Dormers can provide additional useable space and help add interest and variety to otherwise blank roof masses.

Dormer meets exception to height standard

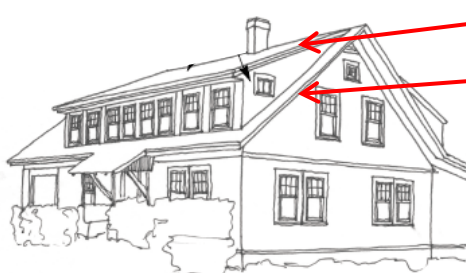

Credit: finehomebuilding.com

Dormer would be calculated for height

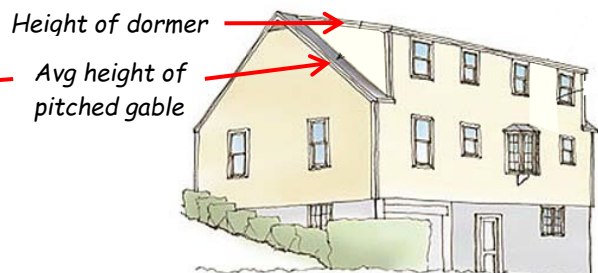

Credit: pro.homeadvisor.com

C. Exceptions to the maximum height.

1. Chimneys, vents, flag poles, satellite receiving dishes and other similar items ~~attached to a building,~~ with a width, depth, or diameter of 3 feet or less may extend above the height limit, as long as they are attached to a building and do not exceed 5 feet above the top of the highest point of the roof. If they are greater than 3 feet in width, depth, or diameter, they are subject to the height limit.
2. Dormers are not included in the height calculation when:
 - a. The roof of the dormer has a pitch of at least 3 in 12 and no part of the dormer extends above the ridgeline of the roof;
 - b. The walls of the dormer are set back at least 12 inches from the plane of any exterior wall of the floor below; and
 - c. The width of the dormer is not more than 75 percent of the width of the roof from which it projects. See Figure 110-1
- ~~3~~2. Farm buildings associated with an agricultural use, such as silos and barns are exempt from the height limit as long as they are set back from all lot lines, at least one foot for every foot in height.
- ~~4~~3. Antennas, utility power poles, and public safety facilities are exempt from the height limit.
- ~~5~~4. Small wind turbines are subject to the standards of Chapter 33.299, Wind Turbines.
- ~~6~~5. Roof mounted solar panels are not included in height calculations, ~~and may exceed the maximum height limit~~ as follows: ~~if the following are met;~~
 - a. For flat roofs or the horizontal portion of mansard roofs, ~~they~~ the roof mounted solar panel may extend up to 5 feet above the top of the highest point of the roof.
 - b. For pitched, hipped or gambrel roofs, ~~they~~ the roof mounted solar panel must be mounted no more than 12 inches from the surface of the roof at any point, and may not extend above the ridgeline of the roof. The 12 inches is measured from the upper side of the solar panel.

Commentary

33.110.215.D. Alternative height limits for steeply sloping lots.

Additional clarity is being added regarding where to measure the average street grade. For the purpose of this regulation, the average street grade will be measured at the street lot line property corners as opposed to somewhere within the sidewalk, the street centerline, or other location within the ROW.

Paragraph 3 is being added because it is currently not clear what to do when a lot both slopes up and down from a street (e.g. through lot or corner lot). The amendment clarifies that in this situation, the applicant can choose to meet the alternative height measurement in D.1.

33.110.220.A Setbacks

The purpose is being amended to clarify that the setback regulations reflect the scale and placement of buildings in the single-dwelling zones as opposed to buildings in other zones across the city.

Figure 110-1
Dormers

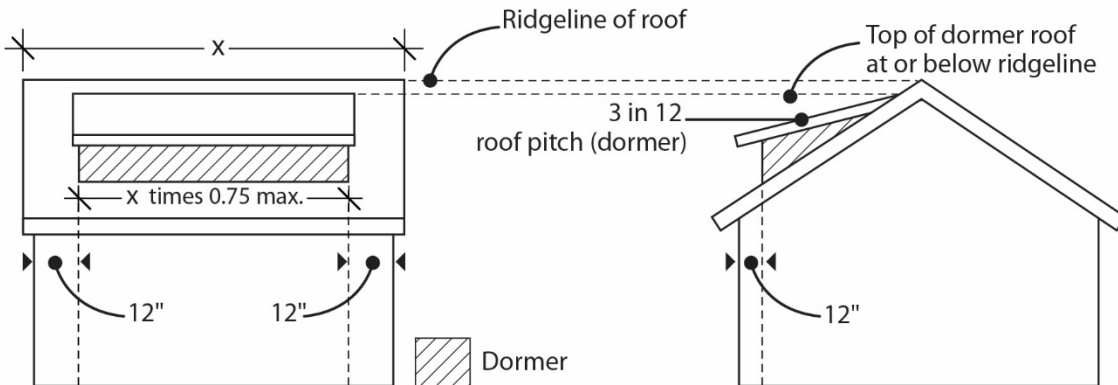

D. Alternative height limits for steeply sloping lots.

1. Downhill slope from street. On lots that slope downhill from the street with an average slope of 20 percent or greater, the height limit is the higher of either 23 feet above the average of the grade of the street or the normal height limit calculated as stated in Chapter 33.930, Measurements. In addition, the alternative height and setback standards of Subsection 33.110.220.D apply. For the purpose of this paragraph, the average grade of the street is measured at the street lot line property corners.
2. Uphill slope from the street. On lots that slope uphill from the street with an average slope of 20 percent or greater the alternative height and setback standards of Subsection 33.110.220.D apply.
3. Downhill and uphill slope from the street. On lots that slope uphill from one street and downhill from another street with an average slope of 20 percent or greater, the applicant may meet the alternative height limit of Paragraph D.1.

33.110.220 Setbacks

A. Purpose. The setback regulations for buildings and garage entrances serve several purposes:

- They maintain light, air, separation for fire protection, and access for fire fighting;
- They reflect the general building scale and placement of ~~houses~~residences in the city's single-dwelling neighborhoods;
- They ~~promote~~foster a reasonable physical relationship between residences;
- They promote options for privacy for neighboring properties;
- They require larger front setbacks than side and rear setbacks to promote open, visually pleasing front yards;
- They provide adequate flexibility to site a building so that it may be compatible with the neighborhood, fit the topography of the site, allow for required outdoor areas, and allow for architectural diversity; and
- They provide room for a car to park in front of a garage door without overhanging the street or sidewalk, and they enhance driver visibility when backing onto the street.

Commentary

33.110.220.C.1.d(4) The limitation on doors in a bay is being deleted to allow for "Juliet" balconies.



33.110.220.C.2. This amendment provides for a consistent 2-foot eave allowance in a setback rather than a percentage of setback to account for the different size setbacks in the single dwelling zones. The change will improve the relationship of eave proportion to building height and width. Requiring at least 3 feet between the eave and the lot line is consistent with the minimum distance required before additional building code regulations for fire protecting eaves are triggered



33.110.220.C.3. This minor amendment is being made to avoid confusion between detached, attached and connected accessory structures and because it is irrelevant whether the stair, deck or ramp is attached, connected or detached.

B. Required setbacks. The required setbacks for buildings and garage entrances are stated in Table 110-4-3. The walls of the garage structure are subject to the front, side, and rear building setbacks stated in Table 110-4-3. The minimum setbacks for institutional uses are stated in 33.110.270245, Institutional Development Standards. Other setbacks may apply to specific types of development or situations.

C. Extensions into required building setbacks.

1. The following features of a building may extend into a required building setback up to 20 percent of the depth of the setback. However, the feature must be at least three feet from a lot line:

- a. ~~Eaves, e~~Chimneys, fireplace inserts and vents, mechanical equipment, and fire escapes;
- b. Water collection cisterns and stormwater planters that do not meet the standard of Paragraph C.32;
- c. Decks, stairways, wheelchair ramps and uncovered balconies that do not meet the standards of Paragraph C.32; and
- d. Bays and bay windows that meet the following requirements:
 - (1) Each bay and bay window may be up to 12 feet long, but the total area of all bays and bay windows on a building facade cannot be more than 30 percent of the area of the facade;
 - (2) At least 30 percent of the area of each bay which faces the property line requiring the setback must be glazing or glass block; and
 - (3) Bays and bay windows must cantilever beyond the foundation of the building; and
 - (4) ~~The bay may not include any doors.~~

2. Building eaves may extend up to two feet into a required building setback provided the eave is at least three feet from a lot line.

32. The following minor features of a building may extend into the entire required building setbacks:

- a. Utility connections attached to the building that are required to provide services such as water, electricity, and other similar utility services;
- b. Gutters and downspouts that drain stormwater off a roof of the structure;
- c. Stormwater planters that are no more than 2-1/2 feet above the ground;
- d. Water collection cisterns that are 6 feet or less in height;
- e. ~~Attached d~~Decks, stairs and ramps that are no more than 2-1/2 feet above the ground. However, stairways and wheelchair ramps that lead to one entrance on the street-facing façade of a building are allowed to extend into the required setback from a street lot line regardless of height above ground; and
- f. On lots that slope down from the street, vehicular or pedestrian entry bridges that are no more than 2-1/2 feet above the average sidewalk elevation.

Commentary

33.110.220.D.2. Exception for flag lots

The setback exception for the side lot line along a flag lot pole is being reduced from 3 to zero. This will reduce the need for an adjustment when a flag lot is being created and the existing house is too close to the new side lot line. The reduced setback is appropriate because the flag pole area will not be developed with anything other than a driveway and there will continue to be at least 10 feet between the existing house and the side lot line of the lot next door.

33.110.220.D.6. Established building lines

This amendment is a minor clarification. The use of the term "new development" is incorrect in the context of this exception. The provision applies to existing nonconforming development which, by definition, is not new development.

- ~~43.~~ Detached accessory structures. The setback standards for detached-accessory structures, including detached mechanical equipment, are stated in 33.110.~~245~~250. Fences are addressed in 33.110.~~275~~255. Detached accessory dwelling units are addressed in Chapter 33.205.

D. Exceptions to the required setbacks.

1. Setback averaging. The front building setback, ~~garage entrance setback~~, and the setback of decks, balconies, and porches may be reduced to the average of the respective setbacks on the abutting lots. See Chapter 33.930, Measurements, for more information.
2. Flag lots. The lot in front of a flag lot may reduce its side building setback along the flag pole lot line to zero~~3 feet~~. ~~Eaves may be within 2 feet of the flag pole lot line.~~ All other setback requirements remain the same.
3. Environmental zone. The front building and garage entrance setback may be reduced to zero where any portion of the site is in an environmental overlay zone. Where a side lot line is also a street lot line the side building and garage entrance setback may be reduced to zero. All other provisions of this Title apply to the building and garage entrance.
4. Steeply sloping lots. This provision applies to lots ~~which~~that slope up or down from the street with an average slope of 20 percent or greater. See Chapter 33.930, Measurements, for more information on how to measure average slope.
 - a. In the RF, R20, R10, and R7 zones, the front building setback for the dwelling may be reduced to 10 feet. However, the height limitations of subparagraph c. ~~below~~ apply. See Figures 110-2 and 110-3.
 - b. In all single-dwelling residential zones, the front building setback for the garage wall and/or the garage entrance setback may be reduced to five feet. However, the height limitations of Paragraph D.4.c. ~~below~~ apply. See Figures 110-2 and 110-3.
 - c. Height limitation. The height limit in the area of the reduced setback is lowered one foot for every foot of reduced setback. See Figures 110-2 and 110-3.
5. Established building lines. The front, side, or rear building setback for the primary structure may be reduced for sites with existing nonconforming development in a required setback. The reduction is allowed if the width of the portion of the existing wall of the primary structure within the required setback is at least 60 percent of the width of the respective facade of the existing primary structure. The building line created by the nonconforming wall serves as the reduced setback line. Eaves associated with the nonconforming wall may extend the same distance into the reduced setback as the existing eave. However, side or rear setbacks may not be reduced to less than 3 feet in depth and eaves may not project closer than 2 feet to the side or rear property line. See Figure 110-4. This reduced setback applies to new development alterations that are ~~that is~~ no higher than the existing nonconforming wall. For example, a second story could not be placed up to the reduced setback line if the existing nonconforming wall is only one story high.

Commentary

33.110.220.D.7. Land Divisions and Planned Developments with existing development

This amendment extends the setback exception for existing development close to a proposed ROW to the RF, R20 and R10 zones and to Planned Developments. Occasionally, ROW is proposed as part of a Planned Development that is not also going through a Land Division and there is no reason to limit the exception to only Land Divisions. Similarly, existing development could be located close to a ROW dedication in the RF, R20 or R10 zones.

33.110.220.D.8. Required dedication

With more opportunities to convert existing houses to add more units, right of way dedications to widen existing rights-of-way may be required. Adding this exception reduces barriers to retaining existing houses and avoids the need for a costly setback adjustment.

6. Split zoning. No setbacks are required from an internal lot line that is also a zoning line on sites with split zoning.
7. Land divisions and Planned Developments with existing development. ~~In the R7, R5, and R2.5 zones,~~ The following setback reductions are allowed when proposed as part of a land division or Planned Development:
 - a. The minimum setback between an existing building and a side lot line along a proposed right-of-way dedication or street tract may be reduced to three feet;
 - b. When a dedication of public right-of-way along the frontage of an existing street is required as part of a land division or Planned Development, the minimum front or side setback between an existing building and a lot line that abuts the right-of-way may be reduced to zero. Future additions or development must meet required minimum setbacks.
 - c. Eaves on an existing building may extend one foot into the reduced setback allowed by D. 7.a. or b. ~~above~~, except they may not extend into the right-of-way.
8. Required dedication. When a dedication of public right-of-way along the frontage of an existing street is required by a public agency, the minimum front or side setback between an existing building and a lot line that abuts the right-of-way may be reduced to zero. Future additions or development must meet required minimum setbacks. Eaves on an existing building may extend one foot into the reduced setback except they may not extend into the right-of-way.
98. Alley. No side, rear, or garage entrance setback is required from a lot line abutting an alley.

Commentary

Language to be **added** is underlined>
Language to be **deleted** is shown in ~~strikethrough~~

Figure 110-2
Exceptions To Front Building Setback And Garage Entrance Setback—Downhill

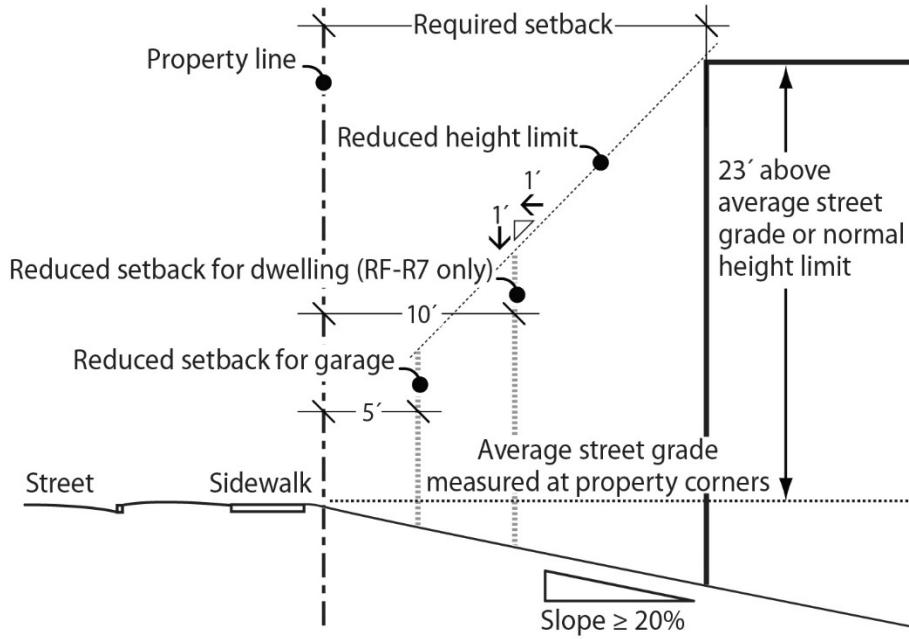
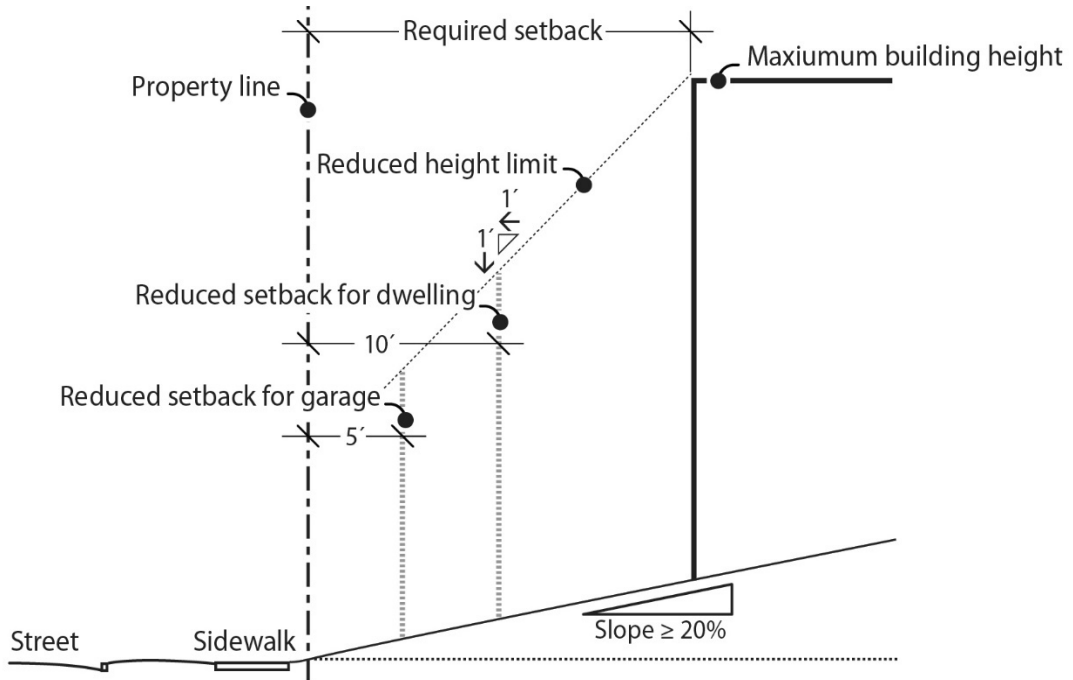

Figure 110-3
Exceptions To Front Building Setback And Garage Entrance Setback—Uphill



Commentary

33.110.225.A

The purpose statement for building coverage is being amended to reflect that the new floor area ratio standard will also work with building coverage to help control the bulk of buildings in the single-dwelling zones.

Language to be **added** is underlined
Language to be **deleted** is shown in ~~strikethrough~~

Figure 110-4
Established Building Lines

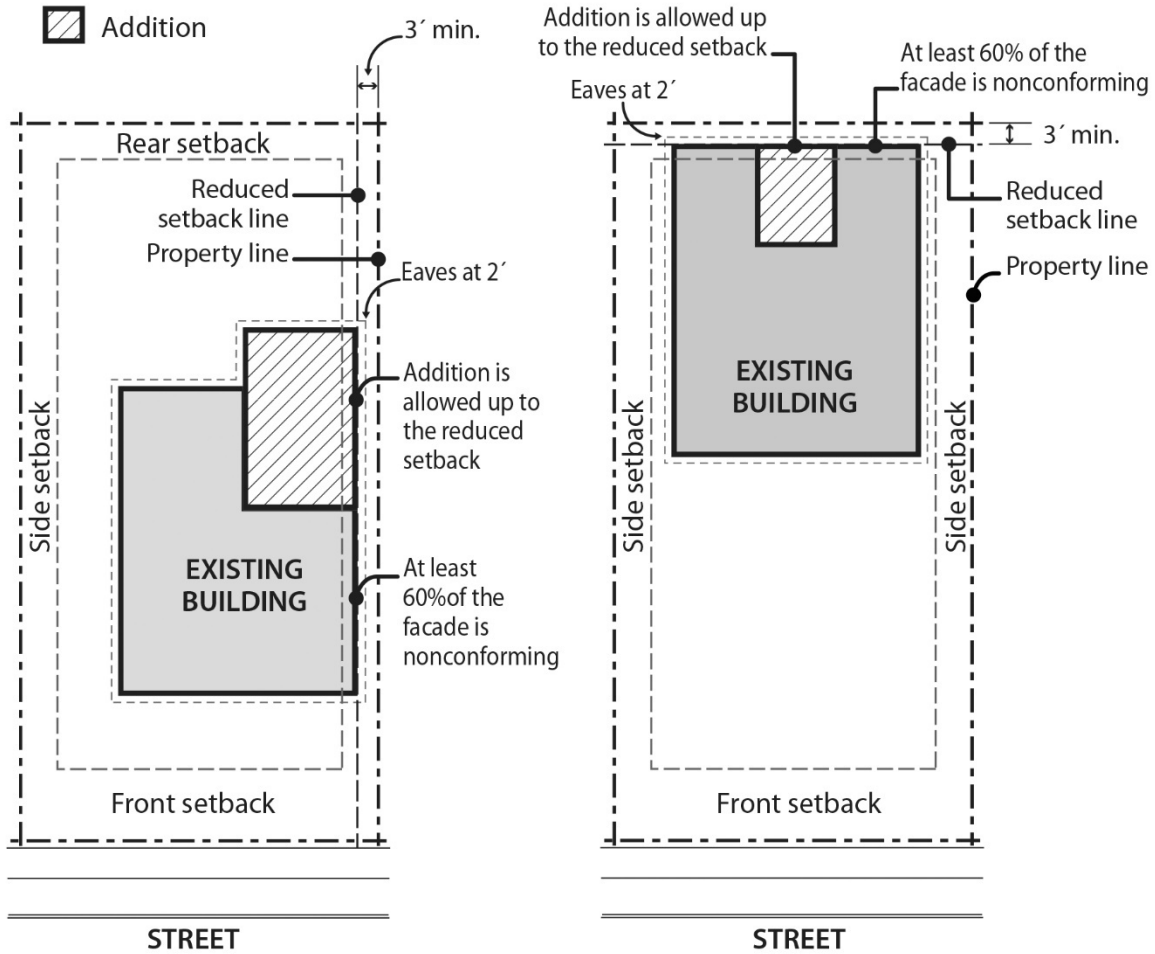

33.110.225 Building Coverage

- A. Purpose.** The building coverage standards, limit the footprint of buildings and work together with the height, ~~and setback, and floor area ratio~~ standards to control the overall bulk of structures. They are intended to ensure~~assure~~ that taller buildings will not have such a large footprint that their total bulk will overwhelm adjacent houses. Additionally, the standards help define the character of the different zones by limiting the amount of buildings allowed on a site.
- B. Building coverage standards.** The maximum combined building coverage allowed on a site for all covered structures is stated in Table 110-6-4.

Commentary

33.110.230.B.1 Where these standards apply

This minor amendment replaces the list of residential structure types to which the main entrance standards apply with the term "all residential structure types except accessory dwelling units". The change in language avoids lengthening the sentence by adding triplex and fourplex.

33.110.230.B.2

This provision is being deleted because it is covered in B.1.

33.110.230.B.4

Development that is located in the special flood hazard area will be exempt from the main entrance standard that limits how high above grade the main entrance can be. In these areas, the lowest floor of the residence is required to be elevated 1 foot above the 100 year flood elevation. In some cases, this is achieved by placing the structure on piers (as opposed to raising the surrounding grade), which could make compliance with this standard impractical.

Lot Size	Maximum Building Coverage
Less than 3,000 sq. ft.	50% of lot area
3,000 sq. ft. or more but less than 5,000 sq. ft.	1,500 sq. ft. + 37.5% of lot area over 3,000 sq. ft.
5,000 sq. ft. or more but less than 20,000 sq. ft.	2,250 sq. ft. + 15% of lot area over 5,000 sq. ft.
20,000 sq. ft. or more	4,500 sq. ft. + 7.5% of lot area over 20,000 sq. ft.

Notes:

[1] Group Living uses are subject to the maximum building coverage for institutional development stated in Table 110-9-5.

33.110.227 Trees

Requirements for street trees and for on-site tree preservation, protection, and overall tree density are specified in Title 11, Trees. See Chapter 11.50, Trees in Development Situations.

33.110.230 Main Entrances in R10 through R2.5 Zones

A. Purpose. These standards:

- ~~Together~~Work with the street-facing facade and garage standards, to ensure that there is a physical and visual connection between the living area of the residence and the street;
- Enhance public safety for residents and visitors and provide opportunities for community interaction;
- Ensure that the pedestrian entrance is visible or clearly identifiable from the street by its orientation or articulation; and
- ~~Ensure that pedestrians can easily find the main entrance, and so establish how to enter the residence.~~
- Ensure a connection to the public realm for development on lots fronting both private and public streets by making the pedestrian entrance visible or clearly identifiable from the public street.

B. Where these standards apply.

1. The standards of ~~Subsection C~~ this section apply to all residential structure types except accessory dwelling units~~houses, attached houses, manufactured homes, and duplexes~~ in the R10 through R2.5 zones;
- ~~2. The standard of Subsection D applies to attached houses on new narrow lots.~~
- ~~23.~~ Where a proposal is for an alteration or addition to existing development, the standards of this section apply only to the portion being altered or added;
- ~~34.~~ On sites with frontage on both a private street and a public street, the standards apply to the site frontage on the public street. On all other sites with more than one street frontage, the applicant may choose on which frontage to meet the standards;~~;~~
- ~~45.~~ Development on flag lots or on lots that slope up or down from the street with an average slope of 20 percent or more is exempt from these standards; ~~and~~
- ~~56.~~ Subdivisions and PUDs that received preliminary plan approval between September 9, 1990, and September 9, 1995, are exempt from these standards;~~;~~ and
6. Development on lots where any portion of the lot is in the special flood hazard area is exempt from the standard in Subsection D.

Commentary

33.110.230.D. Distance from Grade

This standard, which previously applied only to attached houses on new narrow lots (lots created after 2002), will now apply to all residential structure types on all lots. The standard limits long, tall runs, or “floating”, stairways. Applying it to all lots will improve the relationship between the first floor of the dwelling and the surrounding grade. The standard applies only to the one main entrance that meets the street-facing standard of subsection C.

The standard is also being clarified and illustrated with a diagram to show how to measure the average grade (see page 53). The clarification addresses tuck under garages and other excavations that may complicate the calculation of average grade.



Houses with main entrance high above average grade



Main entrances within 4 feet of average grade

The amendment also allows the adjustment review procedure for modifications to the standards rather than requiring a Planned Development. This provides for a more consistent review process when one or more base zone standards are being adjusted.

- C. Location.** At least one main entrance for each structure must:
1. Be within 8 feet of the longest street-facing wall of the dwelling unit; and
 2. Either:
 - a. Face the street. See Figure 110-5;
 - b. Be at an angle of up to 45 degrees from the street; or
 - c. Open onto a porch. See Figure 110-6. The porch must:
 - (1) Be at least 25 square feet in area;
 - (2) Have at least one entrance facing the street; and
 - (3) Have a roof that is:
 - No more than 12 feet above the floor of the porch; and
 - At least 30 percent solid. This standard may be met by having 30 percent of the porch area covered with a solid roof, or by having the entire area covered with a trellis or other open material if no more than 70 percent of the area of the material is open.
- D. Distance from grade.** The main entrance that meets Subsection C, ~~above~~, must be within 4 feet of grade. For the purposes of this Subsection, grade is the average grade measured at the outer most corners of the street facing façade along the foundation of the longest street-facing wall of the dwelling unit. See Figure 110-7. ~~Modifications to this standard are allowed through Planned Development Review. See Chapter 33.638, Planned Development. Adjustments are prohibited.~~

Commentary

Language to be **added** is underlined>
Language to be **deleted** is shown in ~~strikethrough~~

Figure 110-5
Main Entrance Facing the Street

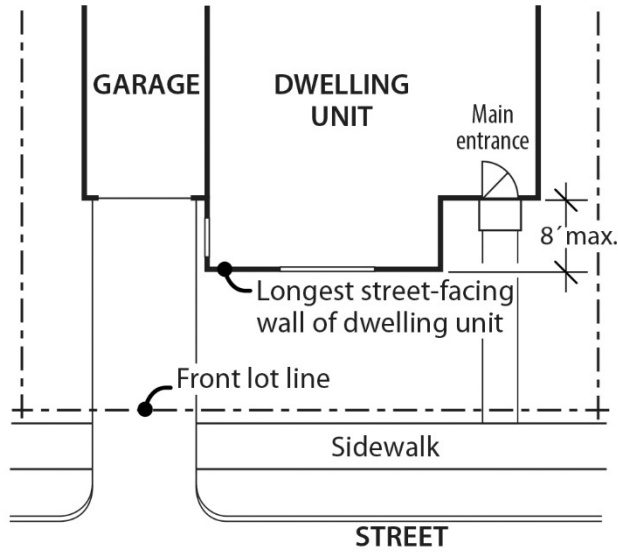
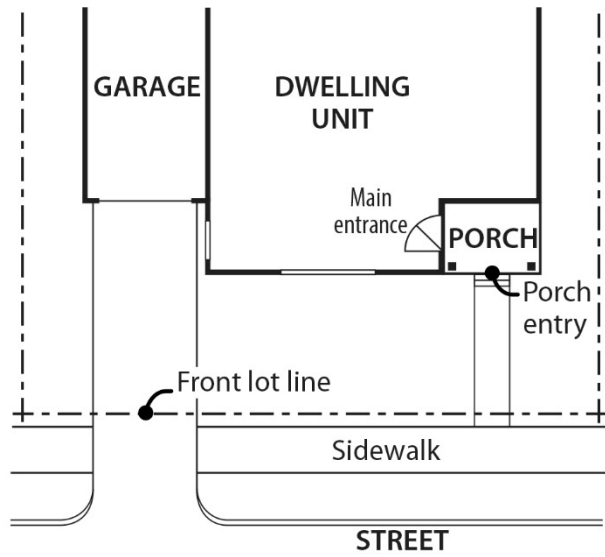

Figure 110-6
Main Entrance Opening onto a Porch



Commentary

Figure 110-7

The figure is being amended to show the new method for measuring average grade.

Language to be **added** is underlined
Language to be **deleted** is shown in ~~strikethrough~~

Figure 110-7
Calculation of Grade: ~~(Elevation A + Elevation B) / 2~~

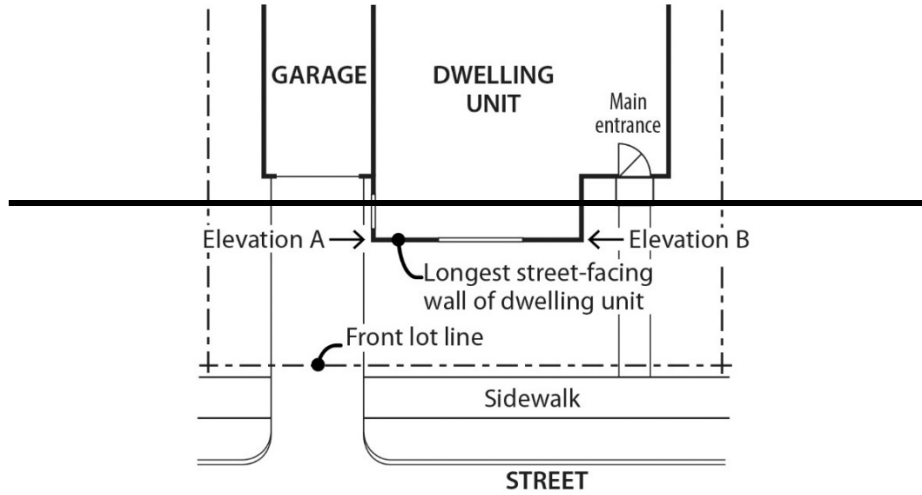
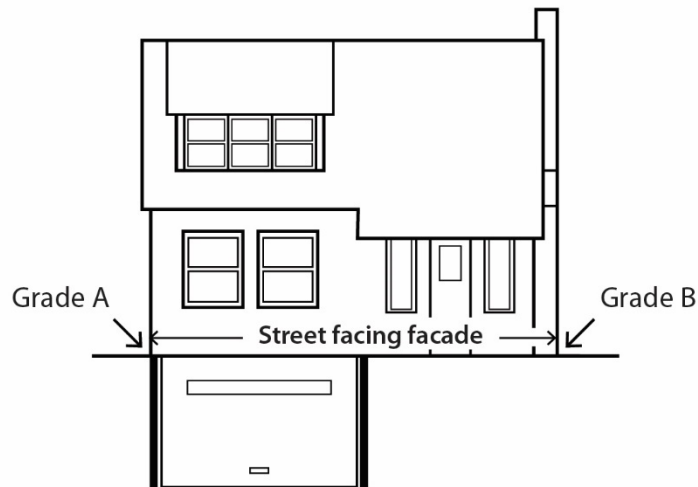

Figure 110-7
Calculation of Grade: (Grade A + Grade B) / 2



Commentary

33.110.235.A.

The purpose statement is being amended to reflect the additional standard related to second story entrances.

33.110.235.B. *Where these standards apply*

This minor amendment replaces the list of residential structure types to which the main entrance standards apply with the term "all residential structure types except accessory dwelling units". The change in language avoids lengthening the sentence by adding triplex and fourplex.

33.110.235.C.

The subsection is being renamed to differentiate the minimum window requirement from the exterior stair standard.

33.110.235.D.

This standard is being added to prevent exterior stairs to a second story from being located between the building façade and a street. Like the main entrance distance from grade standard, this standard will limit long, tall runs, or "floating", stairways on the front façade of a structure and ensure that the front façade is not obscured by a staircase. Stairs to second story entrances will be allowed on non-street side and rear facades.



Example of a second-floor entry on the front façade, which would not be allowed

33.110.235232 Street-Facing Facades in R10 through R2.5 Zones

A. Purpose. ~~This~~The standards:

- ~~Together~~Work with the main entrance and garage standards, to ensures that there is a visual connection between the living area of the residence and the street;
- Enhances public safety by allowing people to survey their neighborhood from inside their residences; and
- Provides a ~~more~~-pleasant pedestrian environment along the street by preventing large expanses of blank facades and façade-obscuring staircases from interrupting the connection between the residence and the public realm~~along streets.~~

B. Where the standards applyies.

1. The street-facing façade standards of this section applyies to all residential structure types except accessory dwelling units~~houses, attached houses, manufactured homes, and duplexes~~ in the R10 through R2.5 zones;
2. Where a proposal is for an alteration or addition to existing development, the applicant may choose to apply the standard either to the portion being altered or added, or to the entire street-facing façade;
3. Development on flag lots or on lots that slope up or down from the street with an average slope of 20 percent or more are exempt from this standard; and
4. In addition, ~~s~~Subdivisions and PUDs that received preliminary plan approval between September 9, 1990, and September 9, 1995, are exempt from this these standards.

C. ~~The standard~~Windows. At least 15 percent of the area of each facade that faces a street lot line must be windows or main entrance doors. Windows used to meet this standard must allow views from the building to the street. Glass block does not meet this standard. Windows in garage doors do not count toward meeting this standard, but windows in garage walls do count toward meeting this standard. To count toward meeting this standard, a door must be at the main entrance and facing a street lot line.

D. Exterior stairs. Fire escapes and exterior stairs providing access to an upper level are not allowed on any facade that faces a street lot line.

Commentary

33.110.240.B Required outdoor area size

The requirement for a minimum outdoor area is being amended to apply per lot rather than per dwelling unit. The experience with accessory dwelling units has been that it is hard to fit in more than one 250 square foot outdoor area and that problem will be exacerbated with the option to build or convert a structure to a triplex or fourplex. In addition, this change also makes the requirement more consistent with the outdoor area requirement in the multi-dwelling zones (48 square feet per unit). Total open area on a site will not be affected by this change because building coverage limits will continue to apply limiting the amount of a lot that can be covered by buildings.

33.110.240.C.2

This amendment will ensure that required outdoor area is not also used as vehicle areas (including storage of vehicles).

33.110.240235-Required Outdoor Areas

- A. Purpose.** The required outdoor areas standards ensure~~assure~~ opportunities in the single-dwelling zones for outdoor relaxation or recreation. The standards work with the maximum building coverage standards to ensure that some of the land not covered by buildings is of an adequate size and shape to be usable for outdoor recreation or relaxation. The location requirements provide options for private or semiprivate areas. The requirement of a required outdoor area serves in lieu of a large rear setback requirement and is an important aspect in addressing the livability of a residential structure.
- B. Required outdoor area sizes.** The minimum sizes of required outdoor areas per lot~~dwelling unit~~ are ~~is~~ stated in Table 110-4-3. The shape of the outdoor area must be such that a square of the stated dimension will fit entirely in the outdoor area.
- C. Requirements.**
1. The required outdoor area must be a contiguous area and may be on the ground or above ground.
 2. The area must be surfaced with lawn, pavers, decking, or sport court paving which allows the area to be used for recreational purposes. User amenities, such as tables, benches, trees, planter boxes, garden plots, drinking fountains, spas, or pools may be placed in the outdoor area. It may be covered, such as a covered patio, but it may not be fully enclosed. Required outdoor area may not be used as vehicle area.
 3. General landscaped areas that~~which~~ are included as part of the required outdoor area may extend into the required side and rear building setback, but the required outdoor area may not be located in the front building setback.

Commentary

33.110.240 Alternative Development Options

This section is being restructured, renamed and moved. See 33.110.265, Residential Infill Options.

Key structural changes:

- The flag lot standards are being moved to 33.110.255. Additional Standards for Flag Lots.
- The transitional site option is being deleted. In the R7, R5, and R2.5 zones, up to 4 units will be allowed on most lots, including transitional sites that presently only allow 2 units. In addition, there are fewer than 15 transitional sites in the R10 and R20 zones and due to the low applicability of this option, it is being deleted.
- The zero lot line development option is being deleted due to difficulties with building code compliance. For example, the building code does not allow window or door openings within 3 feet of a property line and does not allow eaves to project across a property line. In addition, this option has been rarely used.
- The reference to the Permit Ready House program is also being deleted. The permit ready houses program was initiated in 2004/2005. Two pre-approved plans were developed with BDS staff to help administer the program. With the 2009 recession and subsequent budget cuts, this program was discontinued and the plans are no longer under copyright. Twelve houses were built under this program. Due to its seldom use and the lack of flexibility in modifying the copyrighted plans, Chapter 33.278, Permit Ready Houses, was deleted from the zoning code in May, 2018.

33.110.240 Alternative Development Options

A. Purpose. ~~The alternative development options allow for variety in development standards while maintaining the overall character of a single-dwelling neighborhood. These options have several public benefits:~~

- ~~• They allow for development that is sensitive to the environment, especially in hilly areas and areas with water features and natural drainageways;~~
- ~~• They allow for the preservation of open and natural areas;~~
- ~~• They promote better site layout and opportunities for private recreational areas;~~
- ~~• They promote opportunities for affordable housing;~~
- ~~• They promote energy-efficient development;~~
- ~~• They allow for the provision of alternative structure types where density standards are met; and~~
- ~~• They reduce the impact that new development may have on surrounding residential development.~~

B. General requirements for all alternative development options. ~~The alternative development options listed in this section are allowed by right unless specifically stated otherwise. The project must comply with all of the applicable development standards of this section. The project must also conform with all other development standards of the base zone unless those standards are superseded by the standards in this section.~~

C. Attached housing. ~~Attached housing allows for more efficient use of land and for energy-conserving housing.~~

~~1. R20 through R5 zones.~~

~~a. Lot dimensions. Each attached house must be on a lot that complies with the lot dimension standards for new lots in the base zone stated in Chapter 33.610, Lots in RF through R5 Zones.~~

~~b. Building setbacks.~~

~~(1) Interior (noncorner) lots. On interior lots the side building setback on the side containing the common wall is reduced to zero. The reduced setback applies to all buildings on the lot and extends along the full length of the lot line that contains the common or abutting wall. The side building setback on the side opposite the common wall must be double the side setback standard of the base zone.~~

~~(2) Corner lots. On corner lots either the rear setback or nonstreet side setback may be reduced to zero. However, the remaining nonstreet setback must comply with the requirements for a standard rear setback.~~

~~c. Number of units. Two attached houses may have a common wall. Structures made up of three or more attached houses are prohibited unless approved as a Planned Development.~~

Commentary

33.110.240.C.1.d.

The narrow lot landscape standards have been moved to 33.110.260, Additional Standards for Narrow Lots.

~~d.—Landscape standards. The following landscape standards must be met on lots in the R10 through R5 zones that do not meet the minimum lot width standard of 33.610.200.D.1, and were created by a land division submitted after July 1, 2002. Modification of these standards is allowed through Planned Development Review. See Chapter 33.638, Planned Development. Adjustments are prohibited.~~

~~(1) All street facing facades must have landscaping along the foundation. There must be at least one three-gallon shrub for every 3 lineal feet of foundation; and~~

~~(2) Sixty percent of the area between the front lot line and the front building line must be landscaped. At a minimum, the required landscaped area must be planted with ground cover. Up to one-third of the required landscaped area may be for recreational use, or for use by pedestrians. Examples include walkways, play areas, or patios.~~

~~2.—R2.5 zone.~~

~~a.—Density and lot size. The density and minimum lot dimension standards are stated in Chapter 33.611, Lots in the R2.5 Zone, apply.~~

~~b.—Number of units. Up to eight attached houses may have common walls. Structures made up of nine or more attached houses are prohibited.~~

~~c.—Building setbacks.~~

~~(1) Perimeter building setbacks. The front, side, and rear building setbacks around the perimeter of an attached housing project are those of the base zone.~~

~~(2) Interior building setbacks. The side building setback on the side containing the common wall is reduced to zero. The reduced setback extends along the full length of the lot line that contains the common or abutting wall.~~

~~(3) Corner lots. On corner lots either the rear setback or nonstreet side setback may be reduced to zero. However, the remaining nonstreet setback must comply with the requirements for a standard rear setback.~~

~~d.—Landscape standards. The following landscape standards must be met on lots in the R2.5 zone that do not meet the minimum lot width standard of 33.611.200.C.1, and were created by a land division submitted after July 1, 2002. Modification of these standards is allowed through Planned Development Review. See Chapter 33.638, Planned Development. Adjustments are prohibited:~~

~~(1) All street facing facades must have landscaping along the foundation. There must be at least one three-gallon shrub for every 3 lineal feet of foundation; and~~

~~(2) Sixty percent of the area between the front lot line and the front building line must be landscaped. At a minimum, the required landscaped area must be planted with ground cover. Up to one-third of the required landscaped area may be for recreational use, or for use by pedestrians. Examples include walkways, play areas, or patios.~~

Commentary

33.110.240.D.3

The limitation on fire escapes and stairs on the front façade has been incorporated as a general requirement in 33.110.240, Street Facing Façades.

D. ~~Duplex in R2.5 zone.~~ Duplexes are allowed in the R2.5 zone if the following are met:

1. ~~Density. A maximum density of 1 unit per 2,500 square feet of site area is allowed. Density for this standard is calculated before public right-of-way dedications are made;~~
2. ~~Development standards. Duplexes must comply with the height, building setback, building coverage, and required outdoor area requirements of the base zone, overlay zone, or plan district; and~~
3. ~~Front facade. Fire escapes, or exterior stairs that provide access to an upper level are not allowed on the front facade of the building.~~

E. ~~Duplexes and attached houses on corners.~~ This provision allows new duplexes and attached houses in locations where their appearance and impact will be compatible with the surrounding houses. Duplexes and attached houses on corner lots can be designed so each unit is oriented towards a different street. This gives the structure the overall appearance of a house when viewed from either street.

1. ~~Qualifying situations. This provision applies to corner lots in the R20 through R2.5 zones.~~
2. ~~Density. One extra dwelling unit is allowed up to a maximum of two units.~~
3. ~~Lot dimension regulations. Lots in the R20 through R2.5 zones must meet the lot dimension regulations of this section. Adjustments are prohibited.~~
 - a. ~~In the R20 through R7 zones:~~
 - (1) ~~Duplexes. Lots for duplexes must meet the minimum lot dimension standards for new lots in the base zone.~~
 - (2) ~~Attached houses. Where attached houses are proposed, the original lot, before division for the attached house proposal, must meet the minimum lot dimension standards for new lots in the base zone. The new lots created for the attached houses must meet the minimum lot dimension standards stated in Chapter 33.611, Lots in the R2.5 Zone.~~
 - (3) ~~Attached houses as a result of a Property Line Adjustment. Attached houses are allowed on adjusted lots that are a result of a Property Line Adjustment.~~
 - b. ~~In the R5 zone:~~
 - (1) ~~Duplexes. Lots for duplexes must be at least 4,500 square feet in area.~~
 - (2) ~~Attached houses as a result of a land division. Where attached houses are proposed, the original lot, before division for the attached house proposal, must be at least 4,500 square feet. The new lots created for the attached houses must meet the minimum lot dimension standards stated in Chapter 33.611, Lots in the R2.5 Zone.~~
 - (3) ~~Attached houses as a result of a Property Line Adjustment. Attached houses are allowed on adjusted lots that are a result of a Property Line Adjustment.~~

Commentary

~~c. In the R2.5 zone:~~

- ~~(1) Duplexes. Lots for duplexes must be at least 3,000 square feet in area.~~
- ~~(2) Attached houses as a result of a land division. Where attached houses are proposed, the original lot, before division for the attached house proposal, must be at least 3,000 square feet. There are no minimum lot dimension standards for the new lots.~~
- ~~(3) Attached houses as a result of a Property Line Adjustment. Attached houses are allowed on adjusted lots that are a result of a Property Line Adjustment.~~

~~4. Development standards. Both units of the duplex or attached houses must meet the following standards to ensure that the two units have compatible elements. Adjustments to this paragraph are prohibited, but modifications may be requested through Design Review. The standards are:~~

- ~~a. Entrances. Each of the units must have its address and main entrance oriented towards a separate street frontage. Where an existing house is being converted to two units, one main entrance with internal access to both units is allowed;~~
- ~~b. Height. If attached housing is proposed, the height of the two units must be within four feet of each other; and~~

~~c. On both units:~~

- ~~(1) Exterior finish materials. The exterior finish material must be the same, or visually match in type, size and placement.~~
- ~~(2) Roof pitch. The predominant roof pitch must be the same.~~
- ~~(3) Eaves. Roof eaves must project the same distance from the building wall.~~
- ~~(4) Trim. Trim must be the same in type, size and location.~~
- ~~(5) Windows. Windows must match in proportion and orientation.~~

~~**F. Flag lot development standards.** The development standards for flag lots include specific screening and setback requirements to protect the privacy of abutting residences. The following standards apply to development on flag lots:~~

~~1. Setbacks. Flag lots have required building setbacks that are the same along all lot lines. The required setbacks are:~~

Zone	Setback
RF, R20, R10	15 feet
R7, R5, R2.5	10 feet

~~2. Landscaped buffer area. In the R7 through R2.5 zones, on lots that are 10,000 square feet or less in area, a landscaped area is required around the perimeter of the flag lot to buffer the flag portion from surrounding lots. The pole and the lot lines that are internal to the original land division site, or adjacent to an alley, are exempt from this requirement. The landscaped area must be at least 5 feet deep and be landscaped to at least the L3 standard. It may be reduced where the pole portion meets the flag portion to accommodate a 9-foot driveway. See Figure 110-9.~~

Commentary

- ~~3.—Building coverage. Only the area of the flag portion of the flag lot is considered when calculating building coverage. The area of the pole portion of the lot is not included.~~
- ~~4.—Required outdoor area. The required outdoor area may not extend into the required landscaped buffer area required by F.2.~~
- ~~5.—Detached accessory structures. Detached accessory structures may project into the flag lot setbacks as allowed in 33.110.250. However, these structures may not extend into the landscaped buffer area required by F.2.~~

~~**G.—Planned development.** See Chapter 33.270, Planned Developments.~~

~~**H.—Transitional sites.** The transitional site standards allow for a transition of development intensities between nonresidential and single dwelling zones. A stepped increase in density is allowed on single dwelling zoned lots that are adjacent to most commercial/mixed use, employment, industrial, or campus institutional zones. The transitional site provisions promote additional housing opportunities in a way that has minimal impacts on built up single dwelling neighborhoods.~~

- ~~1.—Qualifying situations. The transitional site regulations apply only to sites in the R20 through R2.5 zones that have a side lot line that abuts a lot in the CM2, CM3, CE, CX, E, I, or CI zones. The side lot line of the residential site must abut the lot in a nonresidential zone for more than 50 percent of the residential site's length. The residential site must comply with the minimum lot dimension standards in the applicable base zone listed in Chapters 33.610 and 33.611.~~
- ~~2.—Density. The site may have one dwelling unit more than the density allowed by 33.610.100.C.1 and 33.611.100.C.1.~~
- ~~3.—Housing types allowed. The site may contain a duplex or be divided for attached houses.~~
- ~~4.—Standards for attached housing projects. New lots created for attached houses must meet the minimum lot dimension standards stated in Chapter 33.611, Lots in the R2.5 Zone. Development must meet the site development regulations for attached houses in the R2.5 zone.~~

Commentary

Language to be **added** is underlined>
Language to be **deleted** is shown in ~~strikethrough~~

Figure 110-9
Flag Lot Description and Buffer

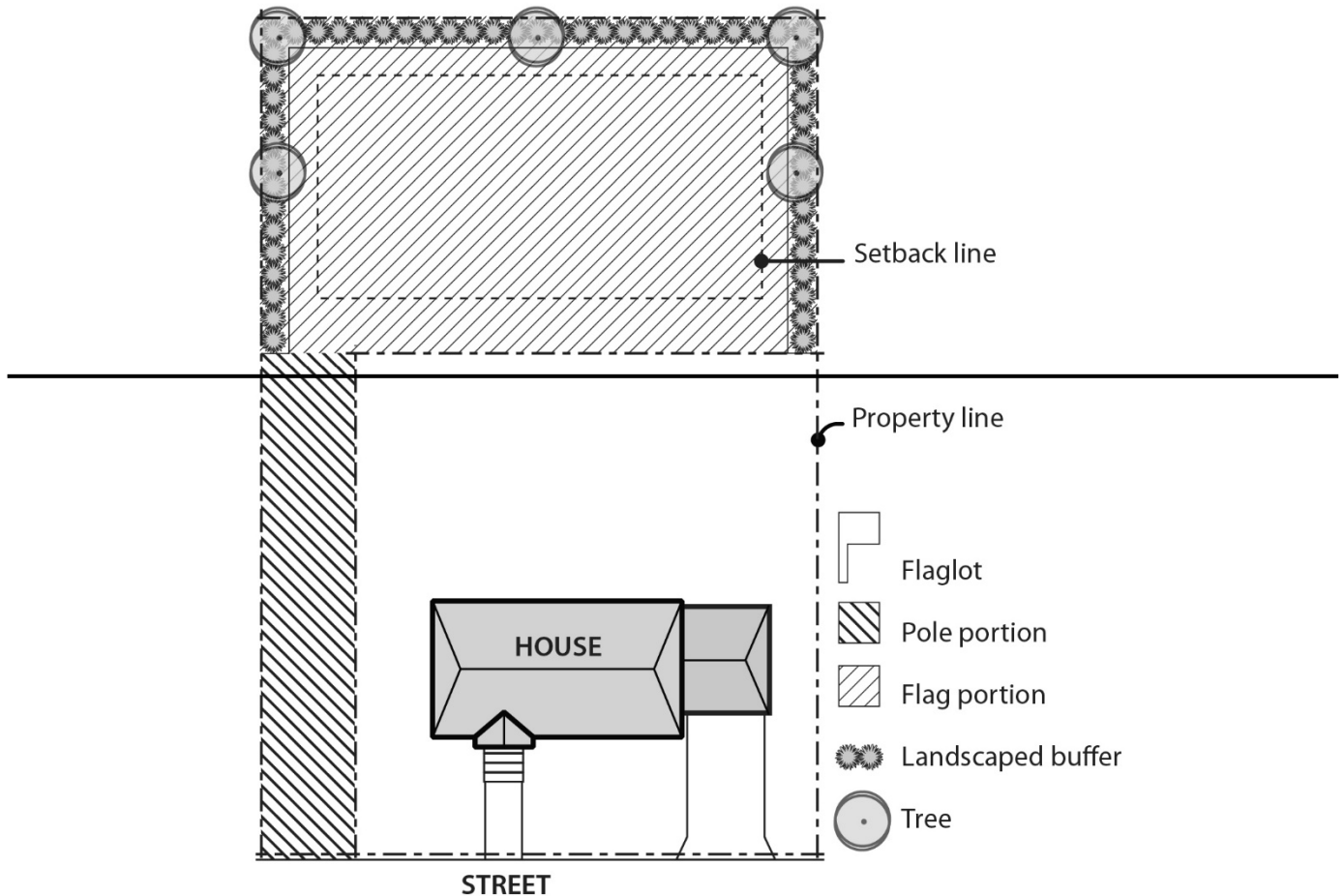

1. Zero lot line. A zero lot line development is where houses in a development on a common street frontage are shifted to one side of their lot. See Figure 110-10. This provides for greater usable yard space on each lot. These developments require that the planning for all of the house locations be done at the same time. Because the exact location of each house is predetermined, greater flexibility in site development standards is possible while assuring that the single dwelling character is maintained.

1. ~~Qualifying situations.~~ Zero lot line developments are allowed for houses in the R20 through R2.5 zones.
2. ~~Procedure.~~ Zero lot line developments are allowed by right. Restrictions which assure the minimum distance between houses, and any required easements, must be recorded on the deeds of the applicable lots. Proof of such recording must be submitted as part of the building permit application.
3. ~~Building setbacks.~~ The side building setback on one side of the house may be reduced to zero. This reduction does not apply to the side building setback adjacent to a street, or to the side building setback adjacent to lots that are not part of the zero lot line project.

Commentary

Language to be **added** is underlined
Language to be **deleted** is shown in ~~strikethrough~~

4. ~~Additional site development standards.~~

- a. ~~Distance between houses. The minimum distance between all buildings in the development must be equal to twice the required side building setback standard of the base zone. A deed restriction must be recorded on the deed of each applicable lot to ensure the continued fulfillment of this setback.~~
- b. ~~Eaves. The eaves on the side of a house with a reduced setback may project a maximum of 18 inches over the adjacent property line. In this case, an easement for the eave projection must be recorded on the deed for the lot where the projection occurs.~~
- c. ~~Maintenance. An easement between the two property owners to allow for maintenance or repair of the house is required when the eaves or side wall of the house are closer than four feet to the adjacent property line. The easement on the adjacent property must be wide enough to allow four feet between the eaves or side wall and the edge of the easement.~~
- d. ~~Privacy. If the side wall of the house is on the property line, or within three feet of the property line, windows or other openings which allow for visibility into the side yard of the adjacent lot are not allowed. Windows that do not allow visibility into the side yard of the adjacent lot, such as a clerestory window or a translucent window, are allowed.~~

J. ~~Permit-Ready Houses.~~ Chapter 33.278 contains provisions for Permit-Ready houses on narrow lots.

Figure 110-10
Zero Lot Line Development

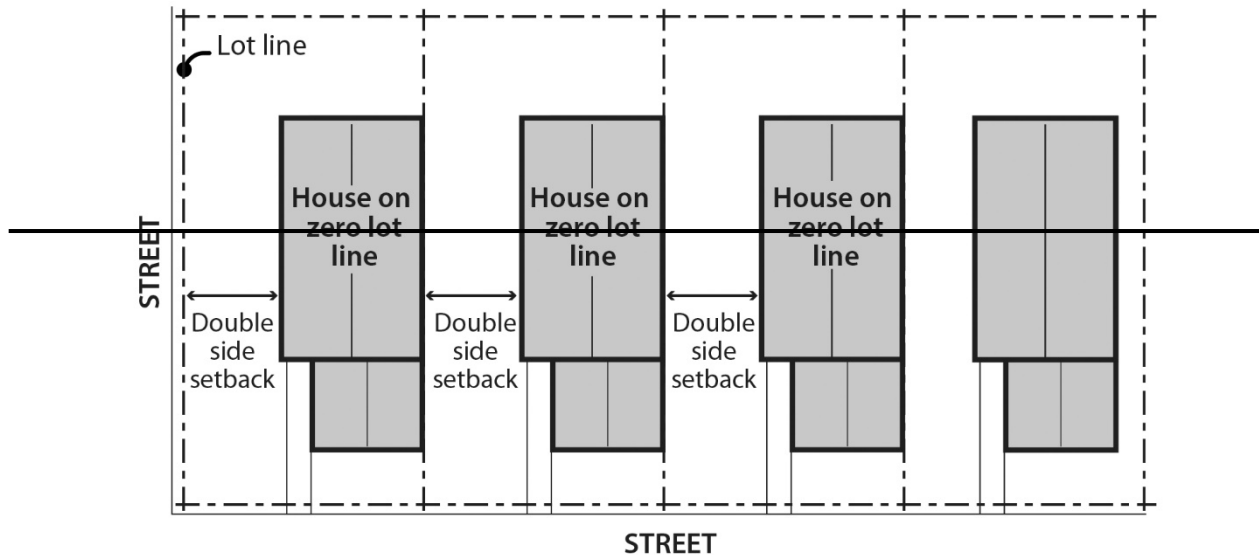

Commentary

33.110.245.B General Standards

The accessory structure standards are being amended to more clearly distinguish between detached accessory structures, connected accessory structures, and attached accessory structures. The accessory structure standards will apply to detached and connected accessory structures. An attached structure that shares a wall, floor or ceiling with a primary building appears like an extension of that building, whereas a structure that is connected via just a breezeway or deck reads more like a detached structure.

See also changes to definitions of attached structure and connected structure in 33.910

	Attached accessory structures (shared wall or floor/ceiling)	Connected accessory structures	Detached accessory structures
Setbacks	Base zone	<ul style="list-style-type: none"> • Reduced side/rear • Connection still subject to base zone setbacks 	Reduced side/rear
Building Coverage	Combined building coverage limit	<ul style="list-style-type: none"> • 15% /not larger than primary structure. • Connections not included in 15% building coverage limit, but counted for site coverage 	15% /not larger than primary structure.
Height	30/35' measured at low point of total bldg	<ul style="list-style-type: none"> • 20' measured at low point of accessory structure • Connection subject to base zone height limit. 	20' measured at low point of accessory structure
Exterior material standards	No	<ul style="list-style-type: none"> • Yes (when taller than 15') • Connection not subject to material standards 	Yes (when taller than 15')



Attached accessory structure



Connected accessory structure

33.110.245250 Detached and Connected Accessory Structures

A. Purpose. This section regulates detached and connected structures that are incidental to primary buildings to prevent them from becoming the predominant element of the site. The standards limit the height and bulk of these structures, promote compatibility of design for larger structures, provide for necessary access around larger structures, help maintain privacy ~~to~~ between abutting lots, and maintain open front setbacks.

B. General standards.

1. The regulations of this section apply to ~~all~~ detached accessory structures and connected accessory structures. Farm structures associated with an agricultural use such as barns and silos are exempt from these standards as long as they are set back from all lot lines at least one foot for every foot in height. Additional regulations for accessory dwelling units are stated in Chapter 33.205.
2. Detached accessory structures are allowed on a lot only in conjunction with a primary building, and may not exist on a lot prior to the construction of the primary structure, except as allowed by Paragraph B.3, ~~below~~.
3. A detached accessory structure that becomes the only structure on a lot as the result of a land division, a property line adjustment, a lot confirmation~~separation of ownership~~, or a demolition of the primary structure may remain on the lot if the owner has executed a covenant with the City that meets the requirements of Section 33.700.060.
 - a. For a land division, the covenant must require the owner to remove the accessory structure if, within two years of final plat approval, a primary structure has not been built and received final inspection. The covenant must be executed with the City prior to final plat approval.
 - b. For a property line adjustment or a lot confirmation~~separation of ownership~~, the covenant must require the owner to remove the accessory structure if a primary structure has not been built and received final inspection within two years. The two years begins on the date the letter from BDS approving ~~confirming~~ the property line adjustment or lot confirmation ~~separation of ownership~~ is mailed. The covenant must be executed with the City before the final letter from BDS is issued.
 - c. For a demolition of a primary structure, the covenant must require the owner to remove the accessory structure if a new primary structure has not been built and received final inspection within two years. The two years begins on the date of the final inspection of the demolition. The covenant must be executed with the City prior to the issuance of the demolition permit.

Commentary

33.110.245.C. Detached and connected covered accessory structures.

Additional clarification is added to distinguish the applicable standards for detached versus connected accessory structures.

33.110.245.C.2.b(2)

Clarification is added to specify that the 24 foot dimension applies to the total footprint of the structure, not just a single dimension.

24' x 24' footprint (dashed line)

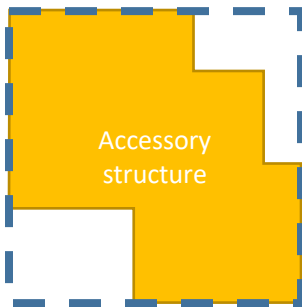

Structure with "dimensions" that do not exceed 24 feet

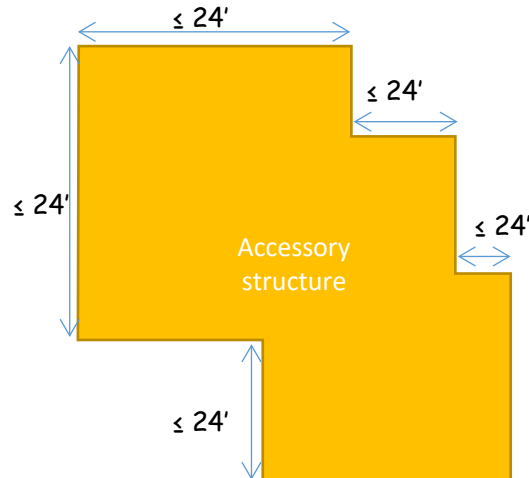

C. Detached and connected covered accessory structures. The following standards apply to all detached covered accessory structures and connected covered accessory structures. Detached covered accessory structures are items such as garages, carports, greenhouses, artist's studios, guest houses, accessory dwelling units, storage buildings, wood sheds, water collection cisterns, and covered decks or patios that are not connected to the primary structure. Connected covered accessory structures include accessory structures that are connected to a primary structure via a roofed structure such as a breezeway. The standards of this subsection do not apply to the portion of the structure that connects the accessory structure to the primary structure. ~~The following standards apply to all detached covered accessory structures.~~ Garages are also subject to the standards of 33.110.~~250~~253.

1. Height. The maximum height allowed for all detached covered accessory structures and connected covered accessory structures is 20 feet.
2. Setbacks. Except as follows, detached covered accessory structures and connected covered accessory structures are subject to required building setbacks. See the additional regulations for garages in 33.110.~~250~~253.
 - a. Water collection cisterns that are 6 feet or less in height are allowed in required side and rear setbacks.
 - b. In the R7, R5 and R2.5 zones, detached covered accessory structures other than water collection cisterns, are allowed in ~~the~~required side and rear building setbacks if all of the following are met:
 - (1) The structure is at least 40 feet from a front lot line, and if on a corner lot, is at least 20 feet from a side street lot line;
 - (2) The structure's footprint has dimensions that do not exceed 24 feet by 24 feet, excluding eaves;
 - (3) If more than one structure is within the setback, the combined length of all structures in the setback adjacent to each property line is no more than 24 feet;
 - (4) The structure is no more than 15 feet high, and the walls of the structure are no more than 10 feet high, excluding the portion of the wall within a gable;
 - (5) The portion of the structure within the setback must be screened from adjoining lots by a fence or landscaping, unless it is enclosed within the setback by a wall. Screening is not required for enclosed structures. Screening must comply with the L3 or F2 standards of Chapter 33.248, Landscaping and Screening;
 - (6) Walls located within the setback do not have doors or windows facing the adjacent lot line;

Commentary

33.110.245.C.2.b(8)

The dormer standard is intended to preserve privacy between lots, however if the dormer faces a lot line that abuts a street, then the dormer does not need to set back 5 feet. This amendment makes that clear.

33.110.245.C.3.a

This amendment clarifies that the building coverage standard for accessory structures applies to detached and connected accessory structures. For example, the building coverage of a garage connected to the house via a breezeway plus a detached shed may not exceed 15% of the total site area.

33.110.245.C.4.

The term "visually match" is being deleted because it is discretionary.

33.110.245.C.4.b. Roof pitch

This amendment clarifies what the term "predominant" was intended to mean.

- (7) The structure does not have a rooftop deck; and
 - (8) Dormers are set back at least 5 feet from the side and rear lot lines that abut another lot.
3. Building coverage. The following additional building coverage standards apply to detached covered accessory structures and connected covered accessory structures:
- a. The combined building coverage of all detached and connected covered accessory structures may not exceed 15 percent of the total area of the site; and
 - b. The building coverage of a detached covered accessory structure may not be greater than the building coverage of the primary structure, and the building coverage of a connected covered accessory structure may not be greater than the building coverage of the primary structure.
4. Additional development standards ~~for detached covered accessory structures~~. The following additional standards apply to detached covered accessory structures and connected covered accessory structures that are more than 15 feet high. Additions to existing structures that do not meet a standard are exempt from that standard.
- a. Exterior finish materials. The exterior finish materials ~~on the detached covered accessory structure~~ must meet one of the following:
 - (1) The exterior finish material must be the same ~~or visually match~~ in type, size and placement, the exterior finish material of the primary structure; or
 - (2) Siding must be made from wood, composite boards, vinyl or aluminum products, and the siding must be composed in a shingle pattern, or in a horizontal clapboard or shiplap pattern. The boards in the pattern must be 6 inches or less in width.
 - b. Roof Pitch. The ~~roof~~ pitch of the roof with the highest ridgeline ~~detached covered accessory structure~~ must meet one of the following:
 - (1) The ~~predominant roof~~ pitch of the roof with the highest ridgeline must be the same as the ~~predominant roof~~ pitch of the roof with the highest ridgeline of the primary structure; or
 - (2) The ~~roof~~ pitch of the roof with the highest ridgeline must be at least 6/12.
 - c. Trim. The trim ~~on the detached covered accessory structure~~ must meet one of the following:
 - (1) The trim must be the same in type, size, and location as the trim used on the primary structure; or
 - (2) The trim around all windows and doors must be at least 3 ½ inches wide.

Commentary

- d. Windows. The windows on all street facing facades ~~of the detached covered accessory structure~~ must meet one of the following:
 - (1) The windows must match those on the street facing façade of the primary structure in orientation (horizontal or vertical); or
 - (2) Each window must be square or vertical – at least as tall as it is wide.
- e. Eaves. The eaves ~~on the detached covered accessory structure~~ must meet one of the following:
 - (1) The eaves must project from the building walls the same distance as the eaves on the primary structure;
 - (2) The eaves must project from the building walls at least 1 foot on all elevations; or
 - (3) If the primary structure has no eaves, no eaves are required.

DE. Detached uncovered vertical structures. Detached uncovered vertical structures are items such as flag poles, trellises, arbors and other garden structures, play structures, antennas, satellite receiving dishes, and lamp posts. The following standards apply to detached uncovered vertical structures. Fences are addressed in 33.110.~~275255~~:

- 1. Height. Except as follows, the maximum height allowed for all detached uncovered vertical structures is 20 feet:
 - a. Antennas, utility power poles, and public safety facilities are exempt from the height limit.
 - b. Flagpoles are subject to the height limit of the base zone for primary structures.
 - c. Detached small wind turbines are subject to the standards of 33.299, Wind Turbines.
- 2. Setbacks. Except as follows, detached uncovered vertical structures are subject to required building setbacks:
 - a. Detached uncovered vertical structures that are no larger than 3 feet in width, depth, or diameter and no taller than 8 feet are allowed in required building setbacks.
 - b. A single arbor structure that is up to 6 feet wide, up to 3 feet deep, and up to 8 feet tall is allowed in the front setback. The arbor must allow for pedestrian access under its span.
 - c. Flagpoles are allowed in required building setbacks.
 - d. In the R7, R5, and R2.5 zones, detached uncovered vertical structures that exceed the allowances of Subparagraph 2.a are allowed in side and rear setbacks if all of the following are met:
 - (1) The structure is at least 40 feet from a front lot line, and if on a corner lot, at least 20 feet from a side street lot line;
 - (2) The structure's footprint has dimensions that do not exceed 24 feet by 24 feet;
 - (3) The structure is no more than 10 feet high;

Commentary

- (4) The portion of the structure within the setback must be screened from adjoining lots by a fence or landscaping, unless it is enclosed within the setback by a wall. Screening is not required for enclosed structures. Screening must comply with the L3 or F2 standards of Chapter 33.248, Landscaping and Screening; and
- (5) The structure does not have a rooftop deck.

EF. **Detached uncovered horizontal structures.** Uncovered horizontal structures are items such as decks, stairways, swimming pools, hot tubs, tennis courts, and boat docks not covered or enclosed. The following standards apply to detached uncovered horizontal structures.

1. Height. The maximum height allowed for all detached uncovered horizontal structures is 20 feet.
2. Setbacks. Except as follows, detached uncovered horizontal structures are subject to required buildings setbacks:
 - a. Detached uncovered decks, ramps, and stairways that are more than 2-1/2 feet above the ground may extend into a required building setback up to 20 percent of the depth of the setback. However, the deck or stairway must be at least three feet from a lot line.
 - b. Structures that are no more than 2-1/2 feet above the ground are allowed in required building setbacks.

FG. **Detached mechanical equipment.** Detached mechanical equipment includes items such as heat pumps, air conditioners, emergency generators, radon mitigation components, and water pumps. Generally, detached mechanical equipment will not be attached to a building but may have components such as ventilation or electrical systems attached to the primary structure. The following standards apply to detached mechanical equipment:

1. Height. The maximum height allowed for all detached mechanical equipment is 20 feet.
2. Setbacks. Except as follows, detached mechanical equipment is subject to required buildings setbacks. Detached mechanical equipment is allowed in side or rear building setbacks if all of the following are met:
 - a. The equipment is no more than 5 feet high; and
 - b. The equipment is screened from adjoining lots by walls, fences or vegetation. Screening must comply with the L3 or F2 standards of Chapter 33.248, Landscaping and Screening.

Commentary

33.110.250.B Additional regulations

This statement is being deleted because it is unnecessary because the accessory structure section already refers to these additional standards.

33.110.250.C.1.

The paragraph is being reworded so that it applies to all garages including garages that are accessory to triplexes and fourplexes. The amendment avoids adding to words triplex and fourplex to the already cumbersome list of structure types.

33.110.250~~253~~ Additional Development Standards for Garages

A. Purpose. These standards:

- Together with the window and main entrance standards, ensure that there is a physical and visual connection between the living area of the residence and the street;
- Ensure that the location and amount of the living area of the residence, as seen from the street, is more prominent than the garage;
- Prevent garages from obscuring the main entrance from the street and ensure that the main entrance for pedestrians, rather than automobiles, is the prominent entrance;
- Provide for a more pleasant pedestrian environment by preventing garages and vehicle areas from dominating the views of the neighborhood from the sidewalk; and
- Enhance public safety by preventing garages from blocking views of the street from inside the residence.

~~**B. Additional Regulations.** The regulations of this Section apply in addition to those of 33.110.250, Accessory Structures.~~

BC. Existing detached garages.

1. Rebuilding. A detached garage that is nonconforming due to its location in a setback, may be rebuilt on the footprint of the existing foundation, if the garage was originally constructed legally. In this case, the rebuilt garage may be no more than 15 feet high, and the garage walls may be no more than 10 feet high, excluding the portion of the wall within a gable. Decks are not allowed on the roof of the garage. The rebuilt garage is not required to comply with other standards of this chapter.
2. Additions. An addition may be made to an existing or rebuilt detached garage that is nonconforming due to its location in a setback as follows:
 - a. The expanded garage complies with all other standards of this chapter; or
 - b. The combined size of the existing foundation and the addition is no larger than 12 feet wide by 20 feet deep. In this case, the garage may be no more than 15 feet high, and the walls of the addition may be no more than 10 feet high, excluding the portion of the wall within a gable. Decks are not allowed on the roof of the garage. The expanded garage is not required to comply with other standards of this chapter.

CD. Length of street-facing garage wall.

1. Where these regulations apply. Unless exempted by Paragraph CE.2, ~~below~~, the regulations of this subsection apply to garages ~~accessory to houses, attached houses, manufactured homes, and duplexes~~ in the R10 through R2.5 zones.
2. Exemptions.
 - a. ~~Garages that are accessory to d~~Development on flag lots, or development on lots which that slope up or down from the street with an average slope of 20 percent or more are exempt from the standards of this subsection.

Commentary

33.110.250.C.2.c

This exemption is being clarified so that when the standard applies to only one street lot line, it is the street lot line with the garage door or garage doors. On corner lots, the standards are not intended to limit a garage that opens to one street from being located on the side of the primary structure that faces the other street (where the inside of the garage wall without the garage door may exceed 50% of the depth of the primary structure).

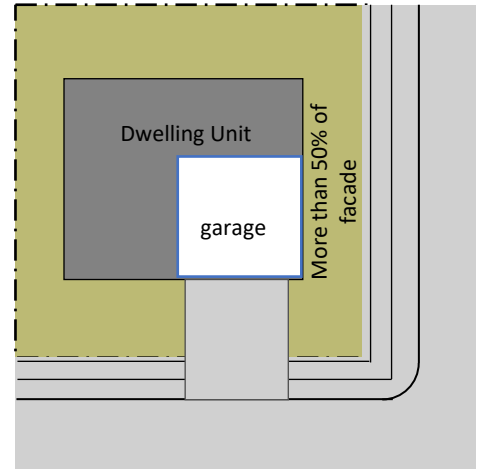

33.110.250.C.3.b

The length of the street-facing garage wall standard is being reorganized to address the introduction of triplexes and fourplexes into the single-dwelling zones and to align with additional limitations on vehicle area between a building and the street that are being added to the Parking chapter (see page 113). The standards are intended to prevent garages from becoming the predominant design element on a street-facing façade, while providing reasonable flexibility for some of the units to have a garage. The standard applies differently but hopefully the outcome is consistent among houses, attached houses, duplexes, triplexes and fourplexes.

For houses, where generally only one built, the standard remains the same—only 50% of the street facing façade can be garage wall. When the façade is less than 22 feet wide, a garage is not allowed because it is hard to park a car in a garage that is less than 11 feet wide.

For attached houses, where each unit is wider than 22 feet, each unit may have up to 50% devoted to garage wall. When any of the units are less than 22 feet wide, then the 50% façade limit will apply to the combined façade of all the units.

For other residential structure types (duplexes, triplexes, and fourplexes) because the units could be arranged side by side (like attached houses) or stacked, applying the standard to each unit is not workable in all cases. Therefore, the 50% garage limit applies to the combined building façade.

For four units (i.e. four narrow attached units or a fourplex), an additional limit is applied. This states that in addition to the 50% limit on garage wall width on a street facing façade, a minimum of 50% of the façade wall that is not garage (i.e. the dwelling unit) must be contiguous. This ensures the building façade is not dominated by multiple garages and driveways that negatively impact the pedestrian experience and effectively eliminate on street parking opportunities.



- b. ~~Garages in~~ Subdivisions and PUDs that received Preliminary Plan approval between September 9, 1990, and September 9, 1995, are exempt from the standards of this subsection.
 - c. On corner lots, only ~~one~~ the street-facing garage wall that contains the garage door must meet the standards of this subsection.
3. Standards.
- a. ~~Garages that are accessory to houses. For garages that are accessory to houses, the~~ length of the-garage wall facing the street may be up to 50 percent of the length of the-street-facing building-façade. See Figure 110-8-11. Where the street-facing facade is less than 22 feet long, an attached garage is not allowed as part of that façade. For duplexes, this standard applies to the total length of the street-facing facades. For all other lots and structures, the standards apply to the street-facing facade of each unit.
 - b. Garages that are accessory to attached houses. The following standards apply to garages that are accessory to attached houses:
 - (1) The length of the garage wall facing the street may be up to 50 percent of the length of the street facing building façade. See Figure 110-8. When all the units are 22 feet wide or wider, the standard applies to the street-facing façade of each unit. In all other situations, the standard applies to the total combined length of the street-facing facades; and
 - (2) When the attached house structure is made up of more than three attached houses and at least one attached house is less than 22 feet wide, at least 50 percent of the total combined length of the street-facing facades must be without garage, and the 50 percent length without garage must be contiguous. See Figure 110-9.
 - c. Garages that are accessory to duplexes, triplexes, and fourplexes. The following standards apply to garages that are accessory to duplexes, triplexes, and fourplexes:
 - (1) The length of the garage wall facing the street may be up to 50 percent of the total combined length of the street-facing building façades. See Figure 110-8. Where the total combined length of the street-facing facades is less than 22 feet long, an attached garage is not allowed; and
 - (2) For a fourplex, at least 50 percent of the total combined length of the street-facing building facades must be without garage, and the 50 percent length without garage must be contiguous. See Figure 110-9.
 - b. ~~Where the street-facing facade is less than 22 feet long, an attached garage is not allowed as part of that façade.~~

Commentary

33.110.250.C.4 and C.5. Exception

These paragraphs provided exceptions for attached garage development on historically narrow lots and new narrow lots. Narrow lot standards are being amended and consolidated into one section 33.110.260, Additional Development Standards For Narrow Lots.

33.110.250.D.3.

To address duplexes, triplexes and fourplexes which may have main entrances on more than a single street facing façade, the standard applies to any street façade where there is a main entrance.

4. ~~Exception. Where the building is not being built on a new narrow lot, the garage wall facing the street may exceed the standards listed in Paragraph D.3 above if D.4.a and either D.4.b or c. are met. See Figure 110-12.~~
 - a. ~~The garage wall facing the street is no more than 12 feet long; and~~
 - b. ~~There is interior living area above the garage. The living area must be set back no more than 4 feet from the street-facing garage wall; or~~
 - c. ~~There is a covered balcony above the garage that is at least the same length as the street-facing garage wall, at least 6 feet deep, and accessible from the interior living area of the dwelling unit.~~
5. ~~For new narrow lots, modifications to the standards of this subsection are allowed through Planned Development Review. See Chapter 33.638, Planned Development. Adjustments are prohibited.~~

DE. Street lot line setbacks.

1. Where this standard applies. The standard of this paragraph applies to garages ~~that are accessory to houses, attached houses, manufactured homes, and duplexes~~ in the R10 through R2.5 zones. Where a proposal is for an alteration or addition to existing development, the standard applies only to the portion being altered or added.
2. Exemptions.
 - a. Development on flag lots or on lots ~~which~~that slope up or down from the street with an average slope of 20 percent or more are exempt from this standard.
 - b. Subdivisions and PUDs that received preliminary plan approval between September 9, 1990, and September 9, 1995, are exempt from this standard.
 - c. Where a lot has more than one street lot line, and there is an existing dwelling unit on the lot, this standard must be met only on the street-facing facade on which the main entrance is located.
3. Standard. A garage wall that faces a street may be no closer to the street lot line than the longest street-facing wall of the dwelling unit. See Figure 110-~~1013~~.
4. Exception. A street-facing garage wall may be up to 6 feet in front of the longest street-facing wall of the dwelling unit, if:
 - a. The street-facing garage wall is 40 percent or less of the length of the building facade; and
 - b. There is a porch at the main entrance. The garage wall may not be closer to the street lot line than the front of the porch. See Figure 110-~~1114~~. The porch must meet the following:
 - (1) The porch must be at least 48 square feet in area and have minimum dimensions of 6 feet by 6 feet;
 - (2) The porch must have a solid roof; and
 - (3) The roof may not be more than 12 feet above the floor of the porch.

Commentary

Figure 110-12 is being deleted from the code because this exception is being deleted.

Language to be **added** is underlined
Language to be **deleted** is shown in ~~strikethrough~~

Figure 110-811
Length of Street-Facing Garage Wall

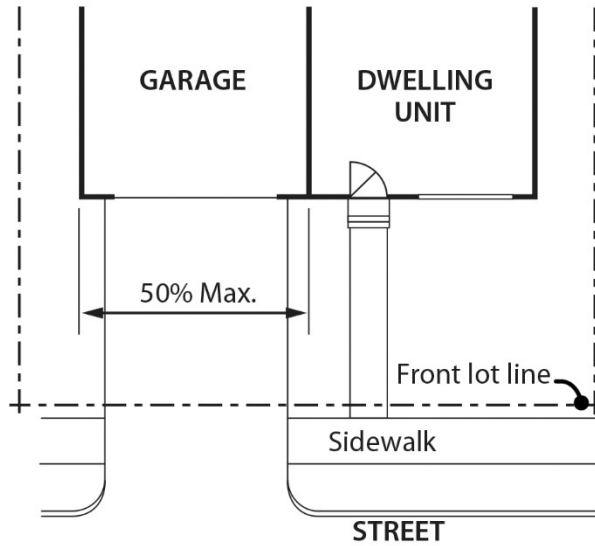
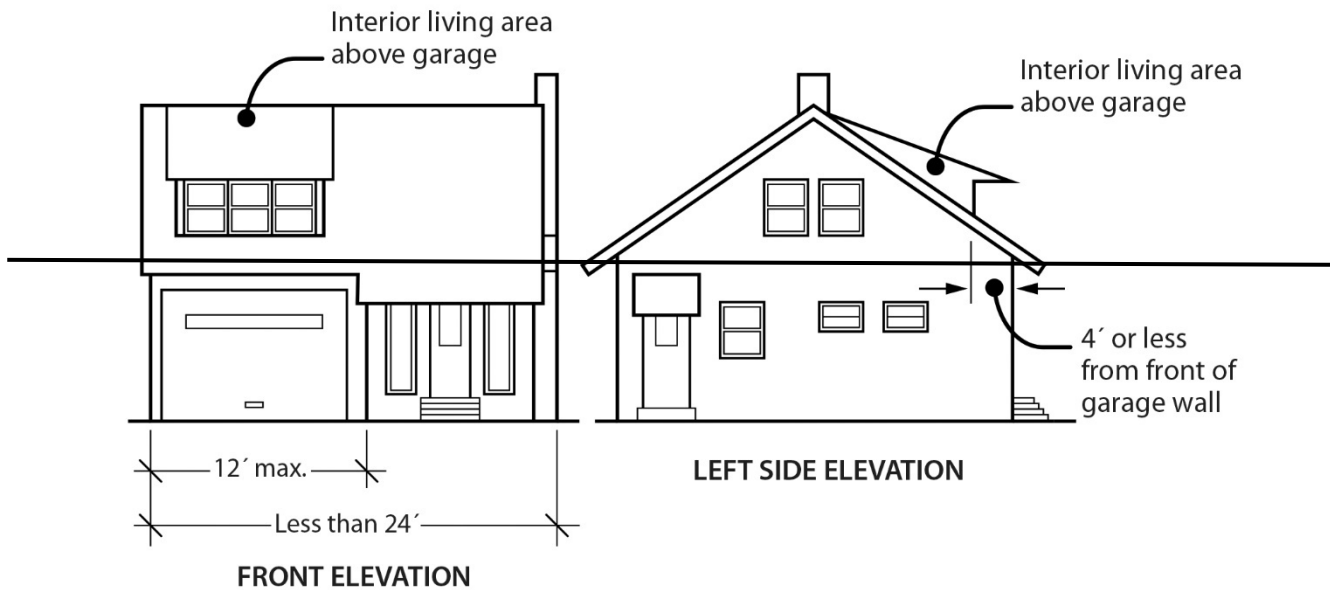

Figure 110-12
Length of Street-Facing Garage Wall Exception



Commentary

Language to be **added** is underlined
Language to be **deleted** is shown in ~~strikethrough~~

Figure 110-9
Combined Length of Street-Facing Garage Wall

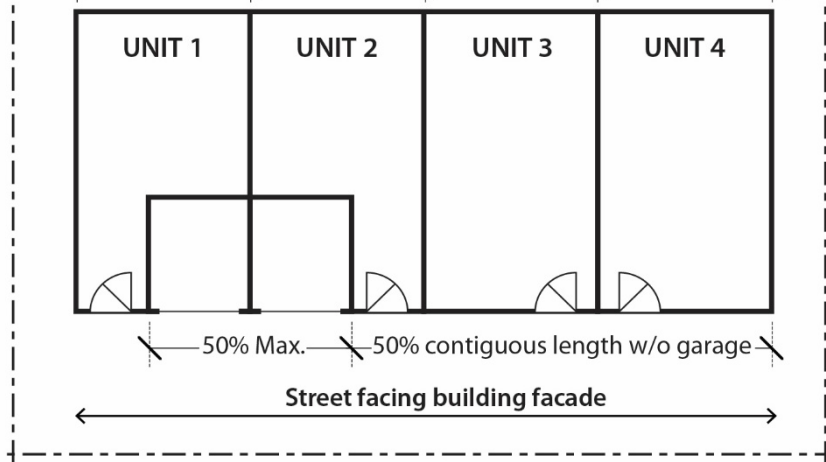
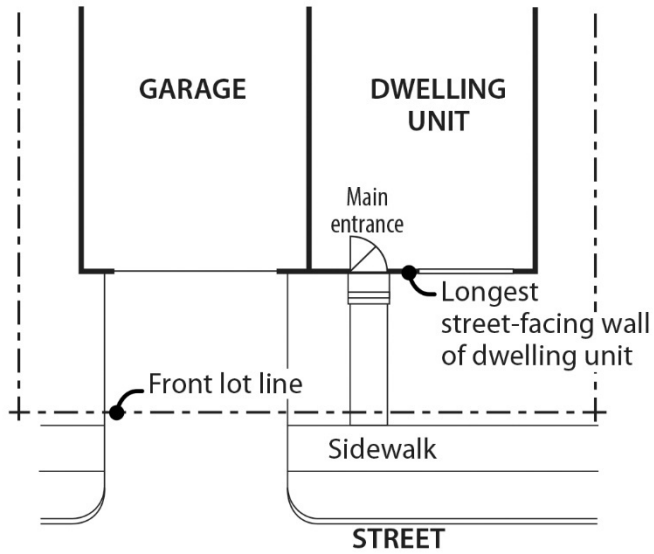

Figure 110-10~~13~~
Street Lot Line Setback



Commentary

Language to be **added** is underlined>
Language to be **deleted** is shown in ~~strikethrough~~

Figure 110-~~1114~~
Garage Front Setback Exception

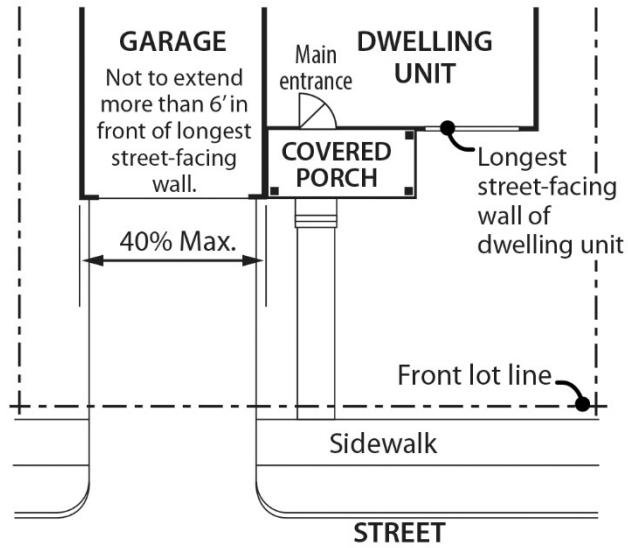

Commentary

33.110.255 Flag Lots

The flag lot standards are being moved from the Alternative Development Options section to their own section so that they are easier to find for user. Flag lots are becoming increasingly common as infill housing is being incorporated onto lots with existing houses.

The standards will also be tailored to large (3000 square feet and larger) and small (less than 3000 square feet) flag lots.

The standards for large flag lot are the same as the previous standards except that the landscape buffer requirement is being amended to apply to any lot 10,000 square feet in area rather than just those lots in R7-R2.5. The change reflects the fact that new lots in the R10 zone can be as small as 6,000 square feet when the overall average lot size is 10,000 square feet.

33.110.255 Additional Development Standards for Flag Lots

A. Purpose. Flag lots encourage additional housing opportunities in a land efficient manner that allows existing homes to be retained. The standards in this section are intended to:

- Protect privacy between the flag lots and abutting residences; and
- Increase the compatibility of structures on small flag lots.

B. Flag lot standards.

1. Large flag lots. The following standards apply to flag lots that are 3,000 square feet or more in area. Only the area of the flag portion of the flag lot is included when calculating area. The pole portion of the flag lot is not included. See Figure 110-11:

a. Setbacks. Large flag lots have required building setbacks that are the same along all lot lines. The required setbacks are:

<u>Zone</u>	<u>Setback</u>
<u>RF, R20, R10</u>	<u>15 feet</u>
<u>R7, R5, R2.5</u>	<u>10 feet</u>

b. Landscaped buffer area. A landscaped area is required around the perimeter of a flag lot that is 10,000 square feet or less in area to buffer the flag portion from surrounding lots. The pole portion of the flag lot is not included when calculating area, and the pole and the lot lines that are internal to the original land division site, or are adjacent to an alley, are exempt from the landscaped area requirement. The landscaped area must be at least 5 feet deep and must be landscaped to at least the L3 standard. Landscaping is not required within the first 10 feet from the point at which the pole portion meets the flag portion of the lot. See Figure 110-12;

c. Building coverage. Only the area of the flag portion of the flag lot is included when calculating building coverage. The area of the pole portion of the lot is not included;

d. Required outdoor area. The required outdoor area may not extend into the required landscaped buffer area required by Subparagraph B.1.b.; and

e. Detached and connected accessory structures. Detached and connected accessory structures may project into the flag lot setbacks as allowed by 33.110.245, Detached and Connected Accessory Structures. However, these structures may not extend into the landscaped buffer area required by Subparagraph B.1.b.

Commentary

Figure 110-12

This figure currently exists as part of 33.110.240, Alternative Development Options and is being moved to this section with the other flag lot standards.

Language to be **added** is underlined>
Language to be **deleted** is shown in ~~strikethrough~~

Figure 110-12
Flag Lot Description and Buffer

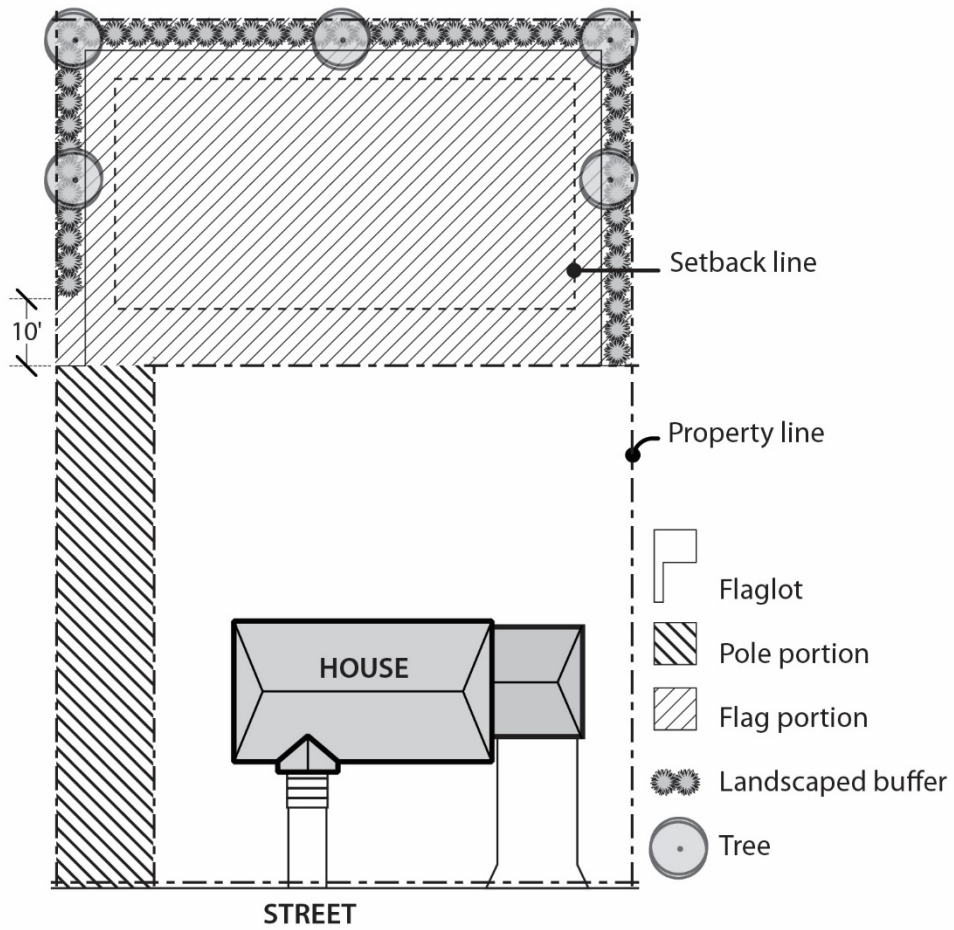

Commentary

33.110.255.C.2. Small flag lots

Standard specifically for development on small flag lots are being added to address structure size and design compatibility. Development on small flag lots (former backyard space) has the potential to overwhelm existing surrounding development especially on small sites with limited area for buffering. While backyard cottages and accessory dwelling units (ADUs) have become more common, without these new standards the size of a house could be up to 1,500 square feet and 30 feet tall on a 3,000 s.f. R5 flag lot. Additional requirements are proposed to ensure more compatible development of these lots in R5 zones.

The new standards generally apply the size, height and design standards that apply to a detached accessory dwelling unit. This includes a maximum floor area limitation, a 20 foot height limit, and material, trim, and eave requirements that encourage matching the house on the front lot. The standards are intended to maintain the relationship between structures on a site with a house and detached ADU in the back yard even when the dwelling unit is a primary unit on its own small flag lot.



NOTE: An existing accessory detached structure is not allowed to become the primary structure on a lot through a property line adjustment or a land division unless a covenant has been signed agreeing to either build a primary structure or remove/convert the accessory structure within 2 years (see 33.110.245.B.3.)

In cases where an accessory dwelling unit becomes the sole structure on the flag lot, a conversion to a primary structure may be possible, once certain code and utility requirements have been reviewed. In some cases, this may mean payment of System Development Charges (since waivers currently apply only to Accessory Dwelling Unit) and combined sewer, storm, water and private utilities will need to be separated and located on their own respective lots. Where the accessory structure is in a setback, an adjustment would also be required.

2. Small flag lots. The following standards apply to flag lots where the flag portion of the lot is less than 3,000 square feet in area:
- a. Duplexes and accessory dwelling units. Duplexes and accessory dwelling units are prohibited on small flag lots;
 - b. Setbacks. Small flag lots have a 5-foot required building setback along all lot lines;
 - c. Building coverage. Only the area of the flag portion of the flag lot is included when calculating building coverage. The area of the pole portion of the lot is not included;
 - d. Floor area. In the RF through R5 zones, the primary structure may not have more than 1,000 square feet of floor area.
 - e. Maximum height. In the RF through R5 zones, the maximum height allowed for all structures is 20 feet.
 - f. Design standards. In the RF through R5 zones, the following design standards apply to structures that are more than 15 feet high:
 - (1) The exterior finish material must be the same in type, size and placement as the exterior finish material on the primary structure on the lot in front of the flag lot, or be made from brick, stucco, wood, composite boards, vinyl or aluminum. Wood, composite boards, vinyl or aluminum siding must be arranged in a shingle, horizontal clapboard, or shiplap pattern. The boards in the pattern must be 6 inches or less in width.
 - (2) The pitch of the roof with the highest ridgeline must be the same as the pitch of the roof with the highest ridgeline of the primary structure on the lot in front of the small flag lot or be at least 6/12.
 - (3) The trim around all windows and doors must be the same as the window and door trim on the primary structure on the lot in front of the flag lot or be at least 3-1/2 inches wide.
 - (4) The eaves must project the same as the eaves on the primary structure on the lot in front of the flag lot, or project from the building walls at least 1 foot on all elevations.

Commentary

33.110.260 Additional Development Standards for Narrow Lots

This section combines the zoning code requirements for historically narrow lots and new narrow lots into one section. The standards have been updated and made consistent for all narrow lots regardless of when they were created.

The standards currently apply based on when the narrow lot was created—historically narrow lots created pre July 26, 1979; new narrow lots created post June 30, 2002; and other narrow lots created between 1979 and 2002. Having three sets of standards applying to the same size and shape lot has been confusing. Development on narrow lots should relate to the lot dimensions and site conditions, not when the lot was created.

The table below compares the current code and amended code. The proposed code applies based on the type of house (attached or detached) and apply to all lots less than 32 feet wide.

Standard	Current Code		Amended Code
	New Narrow Lots	Historically Narrow Lots	All Narrow Lots (<32 feet wide)
House type	Attached houses required (<25' wide lots)	Detached and attached houses allowed	Attached houses required (<26' wide lots)
Street facing garage	Not allowed on facades <22 feet wide	12' wide max allowed	Not allowed on facades <22 feet wide
Parking space/driveway	Parking required	Parking not required	Parking not required Driveways prohibited between building and street (when façade is <22' wide)
Access	Alley access required	Access not limited	Alley access required
Height	1.2 X width of house (R5) 1.5 X width of house (R2.5)	1.5 X width of house (R5&R2.5)	Detached: 1.5 X width of house Attached: 30' (R5) 35' (R2.5)
Setbacks	Base zone	Base zone	Base zone
Main entrance height	Attached houses only	All houses	Base zone (new grade limits apply to all houses)
Building Coverage	50% max	40% max	50% max
Materials, trim, and eaves	Not regulated	Required	Not regulated
Front landscaping	Attached houses only	Not regulated	Required
Exceptions to development standards	<u>Planned Development</u> Garages, height, and landscaping <u>Adjustment</u> Setbacks and building coverage	<u>Design Review</u> Garages, height, setbacks, building coverage, and materials	<u>Adjustment</u> Any exception to additional development standards, including the attached house requirement), except when prohibited

**~~33.110.260~~~~33.110.213~~ Additional Development Standards for Narrow Lots and Lots of Record
Created Before July 26, 1979**

- A. Purpose.** These standards increase the compatibility of residential structures~~new houses~~ on ~~small and narrow lots by:-~~
- Ensuring a reasonably proportional relationship between the width and height of structures on narrow lots;
 - Promoting wider front facades by requiring two attached houses on very narrow lots;
 - Promoting open landscaped front yards;
- B. Where these regulations apply.** The following additional development standards apply to lots, lots of record, and combinations of lots or lots of record that are less than 32 feet wide in the R20 through R2.5 zones. Lots in planned unit developments are exempt from the additional standards.
- ~~1. RF through R7 zones. These regulations apply in the RF through R7 zones, if the lot, lot of record, or combination of lots or lots of record is less than 36 feet wide and has not abutted any lot or lot of record owned by the same family or business on July 26, 1979, or any time since that date.~~
 - ~~2. R5 zone. In the R5 zone, these regulations apply to lots, lots of record, or combinations of lots or lots of record that were created before July 26, 1979 and are:~~
 - ~~a. Less than 3,000 square feet in area; or~~
 - ~~b. Less than 36 feet wide.~~
 - ~~3. R2.5 zone. In the R2.5 zone, these regulations apply to lots, lots of record, or combinations of lots or lots of record that were created before July 26, 1979 and are less than 1,600 square feet in area.~~
 - ~~4. Planned unit developments. Lots in planned unit developments are exempt from the requirements of this section.~~

Commentary

33.110.260.C Standards

This amendment switches the process for modifying this standard from design review to an adjustment review.

33.110.260.C.1

Attached houses will be required on narrow lots (lots 25 feet wide or narrower). This has several benefits:

- Attached houses have wider floorplates and mirror the greater building width of more standard detached houses.
- Attached houses are more energy efficient and require less siding material than detached houses.
- Connecting the houses, coupled with the FAR limits, results in houses that are less deep (43 feet) than detached houses (58 feet) which leaves more useable backyard space.

There are exceptions built into this requirement to acknowledge that there may be existing development on the abutting lots that preclude attaching two houses together. In this case, a detached house will be allowed. In the R20-R5 zones, where there is an odd number of narrow lots and only two attached houses are allowed, a planned development can be requested to allow for more than 2 units to be attached. Alternatively, a pairs of attached houses could be built, and the remaining single lot could be developed with a detached house because the adjacent lots have development that precludes attaching.

33.110.260.C.2

The height limit that previously applied to new narrow lots in the R5 zone is being applied to all residential structures on narrow lots. A 15 foot wide house would be capped at 22.5 feet, while a 25 foot wide or wider house would be capped at 30 feet.

The maximum building coverage, main entrance and garage door standards are being deleted because they are covered by other standards in this chapter.

Figure 110-13

This figure has been clarify to show that minor building projections, like bay windows, are not included in the calculation of facade width for the purposes of determining the maximum height.

C. Standards. ~~Modifications to the standards of this subsection may be requested through Design Review. Adjustments are prohibited. The standards are:~~

1. Required housing type. Attached houses are required on lots and lots of record that are less than 26 feet wide. Attached houses are not required on sites that contain a combination of lots or lots of record when the combination is at least 26 feet wide. Attached houses are also not required when there are primary structures on all of the adjacent sites that share a side lot line with the development site. See 33.110.265.C. for development standards that apply to attached houses.
2. ~~Maximum building coverage.~~ The maximum combined building coverage for structures on lots, adjusted lots, and lots of record in the R5 zone that have not had a dwelling unit on it in the last five years, and is not in an environmental zone is 40 percent.
3. ~~Main entrance.~~ The main entrance that meets Subsection 33.110.230.C, Main entrances in R10 through R2.5 Zones, must be within 4 feet of grade. For the purposes of this requirement, grade is the average grade measured along the foundation of the longest street-facing wall of the dwelling unit. See Figure 110-7;
4. ~~Garage door.~~ In addition to meeting the requirements of 33.110.253.E, if the garage door is part of the street-facing facade, it may not be more than 8 feet wide. If there is more than one garage door, the combined width may not be more than 8 feet;

Figure 110-13
Width of Street-Facing Facade

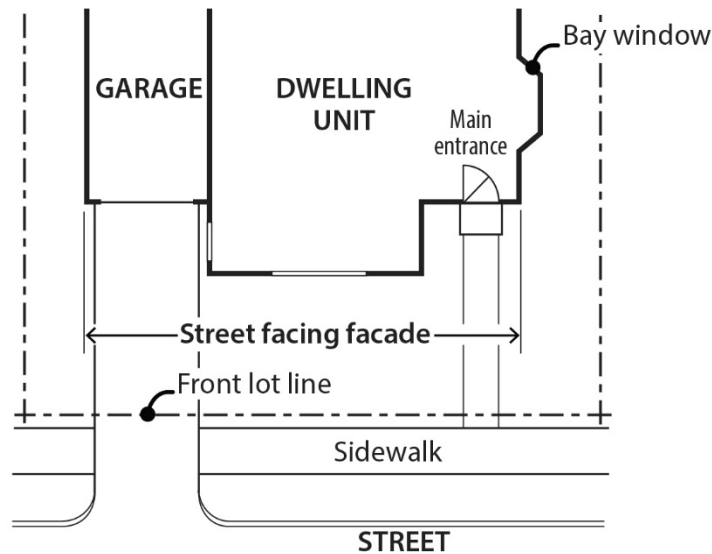

Commentary

33.110.260.C.3

The landscaping standards currently apply to attached houses on new narrow lots but not to historically narrow lots. The standards will now be applied to all narrow lot development to ensure consistency between narrow lots.

The design-related standards are being deleted because they are covered by other standards in this chapter.

3. Landscaping.

- a. All street-facing facades must have landscapng along the foundation. There must be at least one three-gallon shrub for every 3 lineal feet of foundation; and
 - b. Sixty percent of the area between the front lot line and the front building line must be landscaped. At a minimum, the required landscaped area must be planted with ground cover. Up to one-third of the required landscaped area may be for recreational use or for use by pedestrians. Examples include walkways, play areas, and patios.
- ~~5. No parking required. No off-street parking is required.~~
- ~~6. Exterior finish materials. The standards of this paragraph must be met on all building facades.~~
- a. ~~Plain concrete block, plain concrete, corrugated metal, plywood, composite materials manufactured from wood or other products, and sheet pressboard may not be used as exterior finish material, except as secondary finishes if they cover no more than 10 percent of each facade.~~
 - b. ~~Composite boards manufactured from wood or other products, such as hardboard or hardplank, may be used when the board product is less than 6 inches wide;~~
 - c. ~~Where wood products are used for siding, the siding must be shingles, or horizontal siding, not shakes;~~
 - d. ~~Where horizontal siding is used, it must be shiplap or clapboard siding composed of boards with a reveal of 6 inches or less, or vinyl or aluminum siding which is in a clapboard or shiplap pattern where the boards in the pattern are 6 inches or less in width;~~
 - e. ~~Siding material may not cover required window and door trim.~~
- ~~7. Trim. Trim must mark all building rooflines, porches, windows, and doors on all facades. The trim must be at least 3 1/2 inches wide. Buildings with an exterior material of stucco or masonry are exempt from this standard;~~
- ~~8. Eaves. Roof eaves must project from the building wall at least 12 inches on all elevations; and~~
- ~~9. Attached housing. Attached housing is allowed, but no more than two units may be attached. Attached housing allowed under this provision is not subject to the development standards of subsection 33.110.240.C.~~
- ~~10. Setbacks. Adjustments to minimum required setbacks are prohibited. Modifications may be requested through Design Review.~~

Commentary

33.110.265 Residential Infill Options

This new section is one of the more major changes that implement the concepts in the Residential Infill Project.

The 2035 Comprehensive Plan identifies the need for a diversity of housing types in high-amenity areas. The residential infill options have been designed to address that need in R7, R5 and R2.5 zones. Duplexes, triplexes and fourplexes will be allowed on lots in these zones that meet certain size thresholds because these areas generally have convenient access to jobs, services, schools, and other amenities. Areas with constraints that make additional density undesirable will be in a new overlay zones called the Constrained Sites overlay zone (see page 177) and the additional housing types will not be allowed. This section also maintains the existing attached house and corner duplexes provisions from the Alternative Development Options section for the R20 and R10 zones.

33.110.265.C Attached housing

This subsection contains the existing corner and interior lot standards for attached houses that are currently contained in the Alternative Development Options section of Chapter 33.110.

The regulations allows pairs of attached houses in the R20-R5 zones provided the lots meet the minimum lot size for development in the zone (see page 19). No additional density is allowed in this case. On corner lots, an existing lot that is large enough for a house can be divided to the R2.5 lot dimension standards with one additional dwelling allowed. A single historically narrow R5 corner lot could not be additionally divided as the new lots would be too small to meet the R2.5 1,600 sf minimum lot size.

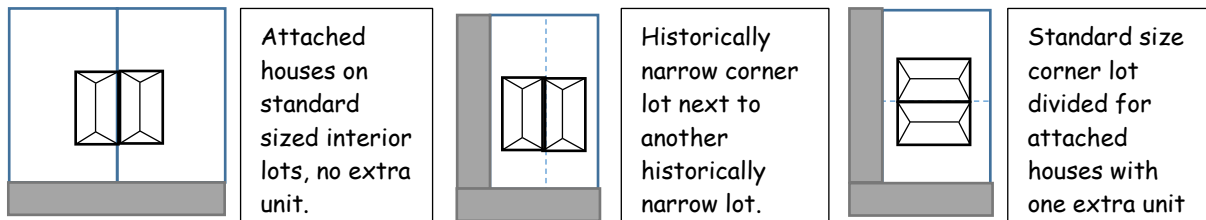

33.110.265 Residential infill options

- A. Purpose.** The residential infill options allow for a variety of residential housing types in a manner that maintains the overall character of single-dwelling neighborhoods. These options have several public benefits:
- They promote housing types that accommodate households of varying sizes and income levels;
 - They promote energy-efficient development;
 - They provide for a more efficient use of residential land; and
 - They promote better site layout and opportunities for private recreational areas.
- B. General requirements for all residential infill options.** The residential infill options listed in this section are allowed by right unless specifically stated otherwise. The project must comply with the applicable development standards of this section.
- C. Attached housing.** Attached housing allows for more efficient use of land and for energy-conserving housing.
1. R20 through R5 zones. Attached houses are allowed as follows:
 - a. Lot dimensions.
 - (1) Interior (noncorner) lots. Each attached house must be on a lot that complies with Section 33.110.202, Development on Lots and Lots of Record.
 - (2) Corner lots. The original lot must comply with Section 33.110.202, Development on Lots and Lots of Record, and the new lots for attached houses must either meet the minimum lot dimension standard stated in Chapter 33.611, Lots in the R2.5 Zone, or must have been created through a Property Line Adjustment. Adjustments are prohibited
 - b. Number of attached houses. Two attached houses may have a common wall. Structures made up of three or more attached houses are prohibited unless approved as a Planned Development.
 - c. Building setbacks. The required building setback on the side containing the common wall is reduced to zero. The reduced setback applies to all buildings on the lot and extends along the full length of the lot line that contains the common or abutting wall.

Commentary

33.110.265.C.2.d Building coverage

Since R2.5 attached house projects can include more than a pair of attached houses, the lot sizes will often vary to accommodate side setbacks on the end units. This creates issues when applying building coverage limits, as the interior lots are smaller (thus less building coverage allowed). This provision allows the building coverage to be applied across the entire site, while including a cap so that no individual lot is allowed more than 5 percent more than would have been allowed otherwise.

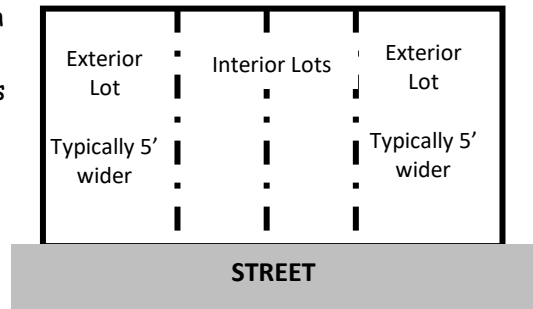

33.110.265.C.2.e Floor Area

Similar to building coverage, with different size lots, the resulting maximum floor area will vary. Because attached houses may also include an ADU, the FAR can also vary per lot between 0.7 and 0.8. This provision allows for a single floor area ratio to be applied to the project site, when all the lots contain the same number of dwelling units, and includes limitations to ensure that FAR is not disproportionately applied to a single lot.

c. Development standards. Both attached houses must meet the following standards to ensure that the two units have compatible elements:

(1) Height. The height of the two units must be within four feet of each other; and

(2) On both units:

- Exterior finish materials. The exterior finish material must be the same in type, size and placement.
- Roof pitch. The roof pitch must be the same.
- Eaves. Roof eaves must project the same distance from the building wall.
- Trim. Trim must be the same in type, size and location.
- Windows. Windows must match in proportion and orientation.

2. R2.5 zone. Attached houses are allowed as follows:

a. Density and lot dimensions. Each attached house must be on a lot that meets the density and minimum lot dimensions stated in Chapter 33.611, Lots in the R2.5 Zone.

b. Number of attached houses. Up to eight attached houses may have common walls. Structures made up of nine or more attached houses are prohibited.

c. Building setbacks. The required building setback on the side containing the common wall is reduced to zero. The reduced setback extends along the full length of the lot line that contains the common or abutting wall.

d. Building coverage. The maximum building coverage of the base zone applies to the entire attached housing project, however the building coverage per lot may not exceed 5 percent more than the base zone maximum.

e. Floor area. The maximum floor area ratio may be applied to the entire attached housing project, however the floor area ratio per lot may not exceed .05 more than the base zone maximum floor area per lot.

Commentary

33.110.265.D. Duplexes

This subsection includes the corner lot duplex standards that currently apply in the R20-R2.5 zones (existing Alternative Development Options) and adds a new allowance for duplexes on interior lot in the R7, R5 and R2.5 zones. The minimum lot sizes for duplexes in the R2.5 and R5 zones have been reduced to be consistent with the minimum lot size for a house and an ADU.

Minimum Lot/Site Size for Duplex		
Zone	Previous Minimum Lot Area	New Minimum Lot Area
R2.5	3,000 sq. ft.	1,600 sq. ft.
R5	4,500 sq. ft.	3,000 sq. ft.
R7	4,200 sq. ft.	4,200 sq. ft.
R10	6,000 sq. ft.	6,000 sq. ft.
R20	12,000 sq. ft.	12,000 sq. ft.

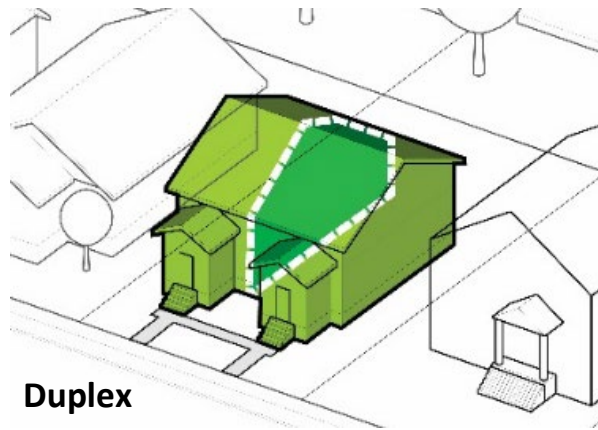

D. Duplexes. Duplexes are allowed on corner lots in the R20 and R10 zones, and on interior and corner lots in the R7 through R2.5 zones as follows:

1. Density. One extra dwelling unit is allowed up to a maximum of two units.
2. Minimum lot area. Lots for duplexes must meet the minimum lot area standard shown in Table 110-7. Adjustments are prohibited

<u>Zone</u>	<u>Minimum Lot Area</u>
<u>R20</u>	<u>12,000 sq. ft.</u>
<u>R10</u>	<u>6,000 sq. ft.</u>
<u>R7</u>	<u>4,200 sq. ft.</u>
<u>R5</u>	<u>3,000 sq. ft.</u>
<u>R2.5</u>	<u>1,600 sq. ft.</u>

3. Compatibility standards. Both units of the duplex must meet the following standards to ensure that the two units have compatible elements. The standards are:
 - a. Exterior finish materials. The exterior finish material must be the same in type, size and placement.
 - b. Roof pitch. The roof pitch must be the same.
 - c. Eaves. Roof eaves must project the same distance from the building wall.
 - d. Trim. Trim must be the same in type, size and location.
 - e. Windows. Windows must match in proportion and orientation.

Commentary

33.110.265.E Triplexes and Fourplexes

Triplexes and fourplexes will be allowed in the R7, R5 and R2.5 zones when lots meet minimum lot size standards. Sites that do not have frontage on at least one improved street will not be eligible to use these provisions because areas with unimproved streets create impediments to access, reducing walkability and bikeability. While new development and conversions to add units would trigger the need for a street improvement or payment of a fee-in lieu (LTIC), the incremental improvements could be mid-block and not connect to the street network or may occur elsewhere.

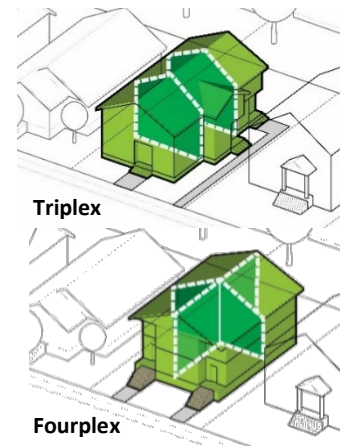

33.110.265.E.2. Minimum Lot Area

The minimum required lot size for a triplex or fourplex is larger than for a duplex. This ensures that sites are large enough to accommodate the triplex or fourplex units, plus suitable yard area and parking if proposed.

Minimum Lot/Site Size for Triplex or Fourplex			
Zone	Minimum Lot Area	FAR	Building Size
R2.5	3,200 sq. ft.	.9	2,880 sq. ft.
R5	4,500 sq. ft.	.7	3,150 sq. ft.
R7	5,000 sq. ft.	.6	3,000 sq. ft.
R10	n/a	-	
R20	n/a	-	

33.110.265.E.3. Visitability

Access to housing for people of all ages and abilities is an important policy objective in the 2035 Comprehensive Plan but current Building Code requirements for "accessible" housing only apply to buildings with 5 or more dwelling units. This provision required on unit in a triplex or fourplex to be visitable. Visitability is a basic level of accessibility that removes barriers for people with temporary or permanent mobility impairments, parents with strollers, seniors and small children.

The requirements do not stipulate that the entire unit be fully accessible as there are significant costs associated with being fully accessible, and specific features will vary depending on a user's needs and desires. Visitability ensures that a residence can be comfortably "visited" by someone regardless of his or her abilities.

33.110.265.E.3.b. VISIBLE unit standards.

There are four basic elements required to be visitable:

- 1) A zero step route and entry to ensure easy access to the unit. The slope of the route can be no steeper than 12.5%.
- 2) Bathroom (sink and toilet) on the floor with the visitable entrance
- 3) Living area with space to entertain and socialize
- 4) Doorways that are at least 34 inches wide. This provides adequate clearance considering the width of the door itself when open.

E. Triplexes and fourplexes. Triplexes and fourplexes that meet the following standards are allowed on interior and corner lots in the R7 through R2.5 zones. To qualify for a triplex or fourplex the lot must abut a street that has been accepted for maintenance by the City of Portland, or the State of Oregon in the case of state highways, or must abut a private street that connects to a street or highway accepted for maintenance by the City or State. See Title 17.42, Property Owner Responsibility for Streets. Payment in lieu of street improvements does not satisfy this requirement.

1. Density. Up to four dwelling units are allowed.
2. Minimum lot area. Lots for triplexes and fourplexes must meet the minimum lot area requirement shown in Table 110-8. Adjustments are prohibited.

Zone	Minimum Lot Area
<u>R7</u>	<u>5,000 sq. ft.</u>
<u>R5</u>	<u>4,500 sq. ft.</u>
<u>R2.5</u>	<u>3,200 sq. ft.</u>

3. Visitability.
 - a. Purpose. Visitability standards ensure that a baseline of accessible features is provided to accommodate people living in or visiting the residence regardless of age or ability. The standards:
 - Promote a diverse supply of more physically accessible housing;
 - Allow people of all ages and abilities to easily enter and visit the residence;
 - Foster community interaction by reducing barriers that can lead to social isolation; and
 - Enhance public safety for all residents and visitors.
 - b. Visitability standards. Unless exempted by Subparagraph E.3.c., at least one dwelling unit on the lot must meet all of the following visitability standards:
 - (1) Visitability entrance. At least one entrance must be accessible via a route that does not have any stairs between it and the street lot line or an on-site parking space. The slope of the route may not exceed 1:8.
 - (2) Visitability bathroom. At least one bathroom must be designed to accommodate an unobstructed circle that is at least 60-inches in diameter. As an alternative, the bathroom may be designed to accommodate an unobstructed "t-shape" area that is comprised of two rectangles that are at least 36 inches by 60 inches, and oriented at right angles to each other. See Figure 110-14. The visitability bathroom must be on the same floor as the visitability entrance or be accessible from the visitability entrance via a ramp, elevator or lift. Adjustments are prohibited;

Commentary

33.110.265.E.3.c. Exemptions.

Certain exemptions are included to address particular site conditions such as slopes and existing development. Steeply sloped lots (>20%) are commonly exempted from additional zoning code standards based on their unique development challenges, especially in terms of making a zero-step entry work.

Internal conversions to add dwelling units to existing structures also present challenges in terms of existing entrances and location of walls and plumbing that new construction has a greater opportunity to plan for and address.

Another common challenge is lots that are elevated from the street. When the highest point along the street lot line to the lowest grade along the front setback is more than 3 feet, then the visitability standards do not apply. Providing for a route that does not exceed 12.5% over a 3-foot rise will require a 24-foot-long ramp. This allows for sufficient room within the front setback to accommodate the ramp.

Flexibility is also provided by allowing the route to the visitable entrance to be from either the street or from an on site parking space.

33.110.265.F. Planned Developments

This provides a reference to the Planned Development Chapter which offers greater infill flexibility in housing type and arrangement configurations.

Language to be **added** is underlined
Language to be **deleted** is shown in ~~strikethrough~~

- (3) Visible living area. There must be at least 70 square feet of living area on the same floor as the visible entrance or 70 square feet of living area must be accessible from the visible entrance via a ramp, elevator or lift. Adjustments are prohibited; and
 - (4) Visible doors. All door openings between and including the visible entrance, visible living area, and the visible bathroom must be at least 34 inches wide. Adjustments are prohibited.
- c. Exemptions. The following are exempt from the standards of this Subsection:
- (1) Lots with an average slope of 20 percent or greater;
 - (2) Lots where there is more than a 3-foot rise between the highest elevation along the street lot line and the lowest grade measured at the front setback.
 - (3) Conversion of an existing residential structure to a triplex or fourplex.

Figure 110-14
Visible Bathroom Clearances

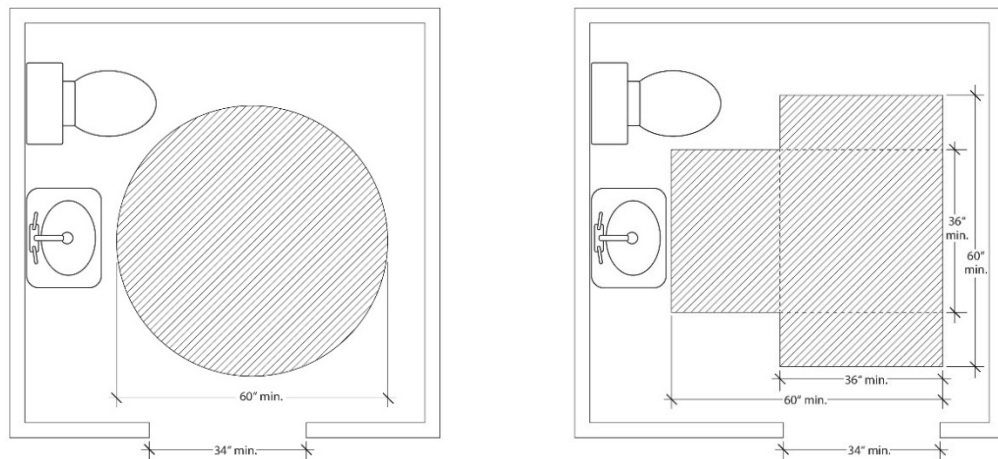

F. Planned development. See Chapter 33.270, Planned Developments.

Commentary

33.110.270245 Institutional Development Standards

- A. Purpose.** The general base zone development standards are designed for residential buildings. Different development standards are needed for institutional uses which may be allowed in single-dwelling zones. The intent is to maintain compatibility with and limit the negative impacts on surrounding residential areas.
- B. Use categories to which these standards apply.** The standards of this section apply to uses in the institutional group of use categories, whether allowed by right, allowed with limitations, or subject to a conditional use review. The standards apply to new development, exterior alterations, and conversions to institutional uses. Recreational fields used for organized sports on a school, school site, or in a park, are subject to Chapter 33.279, Recreational Fields for Organized Sports.
- C. The standards.**
1. The development standards are stated in Table 110-~~9~~5. If not addressed in this section, the regular base zone development standards apply.
 2. Setbacks on a transit street or in a Pedestrian District.
 - a. Purpose. The purpose of these regulations is to reduce reliance on the automobile and encourage pedestrians and transit riders by ensuring safe and convenient pedestrian access to buildings.
 - b. Building setbacks on a transit street or in a Pedestrian District. Buildings on a transit street or in a Pedestrian District must meet the provisions of 33.120.220.C.
 - c. Conflicts.
 - (1) If the depth of the minimum building setback or buffering standards conflicts with the maximum building setback standard, the depth of the maximum building setback standard supersedes the depth of the minimum building setback and buffering standards.
 - (2) If the depth of the minimum setback standard for detached accessory structures conflicts with the depth of the minimum buffering standard, the depth of the minimum buffering standard supersedes the depth of the minimum setback standard for detached accessory structures.
 - d. Exception. Development that is not subject to conditional use review under Section 33.815.040 is exempt from the maximum transit street setback requirement.
 3. Exterior storage. Exterior storage of materials or equipment is prohibited.
 4. Outdoor activity facilities. Except as specified in paragraph C.5. below, outdoor activity facilities, such as swimming pools, basketball courts, tennis courts, or baseball diamonds must be set back 50 feet from abutting R-zoned properties. Playground facilities must be set back 25 feet from abutting R-zoned properties if not illuminated, and 50 feet if illuminated. Where the outdoor activity facility abuts R-zoned properties in School uses, the required setback is reduced to zero.
 5. Recreational fields for organized sports. Recreational fields used for organized sports on a school, school site, or in a park, are subject to Chapter 33.279, Recreational Fields for Organized Sports.

Commentary

33.110.270.C.6 Mechanical Equipment

The mechanical equipment screening requirement is being amended to clarify that mechanical equipment on the roof of an institution only needs to be screened when it is located within 50 feet of an adjacent residential lot. Because the institutional lot is also zoned residential, the current wording of the standard could be read to imply that the mechanical equipment needs to be screened even when it is far from an adjacent lot.

6. Mechanical equipment. Mechanical equipment located on the ground, such as heating or cooling equipment, pumps, or generators must be screened from the street and any abutting residential zones by walls, fences, or vegetation. Screening must comply with at least the L2 or F2 standards of Chapter 33.248, Landscaping and Screening, and be tall enough to screen the equipment. Mechanical equipment placed on roofs must be screened in one of the following ways; if the equipment is within 50 feet of an abutting R zoned lot:
 - a. A parapet along facades facing the R zone that is as tall as the tallest part of the equipment;
 - b. A screen around the equipment that is as tall as the tallest part of the equipment; or
 - c. The equipment is set back from roof edges facing the R zone 3 feet for each foot of height of the equipment.
7. Electrical substations. In addition to the standards in Table 110-~~9-5~~, the entire perimeter of electrical substations, including the street lot line (except for the access point), must be landscaped to the L3 standards stated in Chapter 33.248. This landscaping must be planted on the outside of any security fence. Electrical substations that are in a fully enclosed building are exempt from this requirement.
8. Grassy areas. Grassy play areas, golf courses, cemeteries, and natural areas are not subject to the L3 landscaping standard of Table 110-~~9-5~~ and are exempt from the setback standard of Paragraph 4, above.
9. Garbage and recycling collection areas. All exterior garbage cans. Garbage collection areas, and recycling collection areas must be screened from the street and any adjacent properties. Trash receptacles for pedestrian use are exempt. Screening must comply with at least the L3 or F2 standards of Chapter 33.248, Landscaping and Screening. See Section 17.102.270, Business and Multifamily Complexes Required to Recycle, of the Portland City Code for additional requirements for recycling areas.
10. Pedestrian standards. The on-site pedestrian circulation system must meet the standards of Section 33.120.255, Pedestrian Standards.

Commentary

Footnote [5]

Footnote 5 is being amended to replace "surface parking lot" with "vehicle area". Surface parking does not include driveways and the driveway to a parking area on a site with an institution should be subject to parking lot landscaping and setback standards. The text has also been amended to reflect the updated name of Chapter 266.

Table 110-9-5 Institutional Development Standards [1]	
Minimum Site Area for New Uses	10,000 sq. ft.
Maximum Floor Area Ratio [2]	0.5 to 1
Maximum Height [3]	50 ft.
Minimum Building Setbacks [2]	1 ft. back for every 2 ft. of bldg. height, but in no case less than 15 ft.
Maximum Building Setback Transit Street or Pedestrian District [7]	20 ft. or per CU/IMP review
Maximum Building Coverage [2]	50% of site area
Minimum Landscaped Area [2,4]	25% of site area to the L1 standard
Buffering from Abutting Residential Zone [5]	15 ft. to L3 standard
Buffering Across a Street from a Residential Zone [5]	15 ft. to L1 standard
Setbacks for All Detached Accessory Structures Except Fences [6]	10 ft.
Parking and Loading	See Chapter 33.266, Parking And Loading
Signs	See Title 32, Signs and Related Regulations

Notes:

[1] The standards of this table are minimums or maximums as indicated. Compliance with the conditional use approval criteria might preclude development to the maximum intensity permitted by these standards.

[2] For campus-type developments, the entire campus is treated as one site. Setbacks are only measured from the perimeter of the site. The setbacks in this table only supersede the setbacks required in Table 110-4-3. The normal regulations for projections into setbacks and for detached accessory structures still apply.

[3] Towers and spires with a footprint of 200 square feet or less may exceed the height limit, but still must meet the setback standard. Elevator mechanical equipment that is set back at least 15 feet from all roof edges on street facing facades may extend up to 16 feet above the height limit. Other mechanical equipment and stairwell enclosures that provide rooftop access when these cumulatively cover no more than 10 percent of the roof area and are set back at least 15 feet from all roof edges on street facing facades may extend up to 10 feet above the height limit.

[4] Any required landscaping, such as for required setbacks or parking lots, applies towards the landscaped area standard.

[5] ~~Surface parking lots~~ Vehicle areas are subject to the parking lot setback and landscaping standards stated in Chapter 33.266, ~~Parking And Loading And Transportation And Parking Demand Management~~.

[6] Setbacks for structures that are accessory to recreational fields for organized sports on a school, school site, or in a park, are stated in Chapter 33.279, Recreational Fields for Organized Sports.

[7] The maximum building setbacks are described in 33.110.270-245.C.

33.110.275-255 Fences

- A. Purpose.** The fence standards promote the positive benefits of fences without negatively impacting the community or endangering public or vehicle safety. Fences can create a sense of privacy, protect children and pets, provide separation from busy streets, and enhance the appearance of property by providing attractive landscape materials. The negative effects of fences can include the creation of street walls that inhibit police and community surveillance, decrease the sense of community, hinder emergency access, hinder the safe movement of pedestrians and vehicles, and create an unattractive appearance. These standards are intended to promote the positive aspects of fences and to limit the negative ones.

Commentary

33.110.275.C.1. Front Building Setbacks

Currently, fence height is limited to 3-1/2 feet within the front setback even if the house is closer to the front lot line than the required setback. This amendment will allow the taller fence can be built in line with the front of the house in this nonconforming situation.

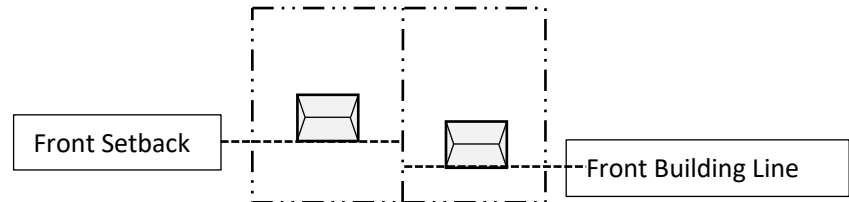

B. Types of fences. The standards apply to walls, fences, and screens of all types whether open, solid, wood, metal, wire, masonry, or other material.

C. Location and height.

1. Front building setbacks. Fences up to 3-1/2 feet high are allowed in required front building setbacks, or between the front lot line and the front building line of the primary structure, whichever is less.
2. Side and rear building setbacks.
 - a. Fences up to 8 feet high are allowed in required side or rear building setbacks that do not abut a pedestrian connection.
 - b. Fences abutting a pedestrian connection.
 - (1) Fences up to 8 feet high are allowed in required side or rear building setbacks that abut a pedestrian connection if the pedestrian connection is part of a right-of-way that is at least 30 feet wide.
 - (2) Fences up to 3-1/2 feet high are allowed in required side or rear building setbacks that abut a pedestrian connection if the pedestrian connection is part of a right-of-way that is less than 30 feet wide.
3. Exceptions for corner lots. On corner lots, if the main entrance is on the facade facing the side street lot line, the applicant may elect to meet the following instead of C.1 and C.2. See Figure 110-15.
 - a. Fences up to 3-1/2 feet high are allowed within the first 10 feet of the side street lot line.
 - b. Fences up to 3-1/2 feet high are allowed in required setbacks that abut a pedestrian connection if the pedestrian connection is part of a right-of-way that is less than 30 feet wide;
 - c. Fences up to 8 feet high are allowed in the required front building setback, outside of the area subject to 3.a.
 - d. Fences up to 8 feet high are allowed in all other side or rear building setbacks.
4. Not in building setbacks. The height for fences that are not in required building setbacks is the same as the regular height limits of the zone.

Commentary

Figure 110-15
Fence Height Option on Corner Lots

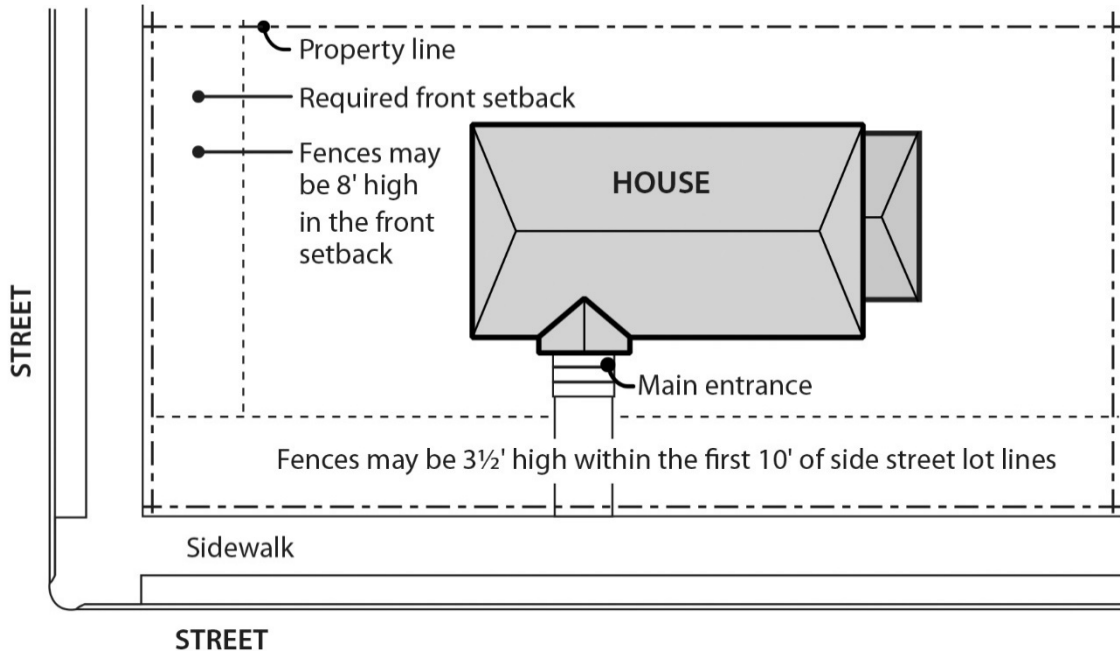

- D. Reference to other regulations.** Electrified fences are regulated under Title 26, Electrical Regulations. The use of barbed wire is regulated under Title 24, Building Regulations.

33.110.280~~33.110.257~~ Retaining Walls

- A. Purpose.** The standards of this section help mitigate the potential negative effects of large retaining walls. Without mitigation, such walls can create a fortress-like appearance and be unattractive. By requiring large walls to step back from the street and provide landscaping, the wall is both articulated and visually softened.
- B. Where these regulations apply.**
1. Generally. These regulations apply to the portions of street-facing retaining walls that are in required setbacks along street lot lines. Where there is no required setback, or the setback is less than 10 feet, the regulations apply to the first 10 feet from the line.
 2. Exceptions. The following are not subject to the regulations of this section:
 - a. Retaining walls in the areas described in B.1 that are less than four feet high, as measured from the bottom of the footing.
 - b. Retaining walls on sites where the site slopes downward from a street in the area described in B.1.
 - c. Retaining walls on sites where the site slopes upward from a street and the existing slope within the area regulated by B.1 is 50 percent or more.
 - d. Replacing an existing retaining wall, where the replacement will not be taller or wider than the existing wall.

Commentary

- e. Retaining walls on sites where any portion of the site is in an environmental overlay zone.

C. Standards.

1. Retaining walls are limited to 4 feet in height measured from the bottom of the footing, as shown in Figure 110-16.
2. Retaining walls must be set back at least 3 feet from other street-facing retaining walls, as shown in Figure 110-16. The 3 foot setback area must be landscaped to at least the L2 standard, except that trees are not required. A wall or berm may not be substituted for the shrubs.

33.110.285260 Demolitions

- A. Generally.** Demolition on a site that requires a demolition permit is subject to the tree preservation and protection requirements of Title 11, Trees. See Chapter 11.50, Trees in Development Situations.
- B. Historic resources.** Demolition of historic resources is regulated by Chapter 33.445, Historic Resource Overlay Zone.

33.110.290270 Nonconforming Development

Existing developments that do not conform to the development standards of this chapter may be subject to the regulations of Chapter 33.258, Nonconforming Situations.

**Figure 110-16
Retaining Walls**

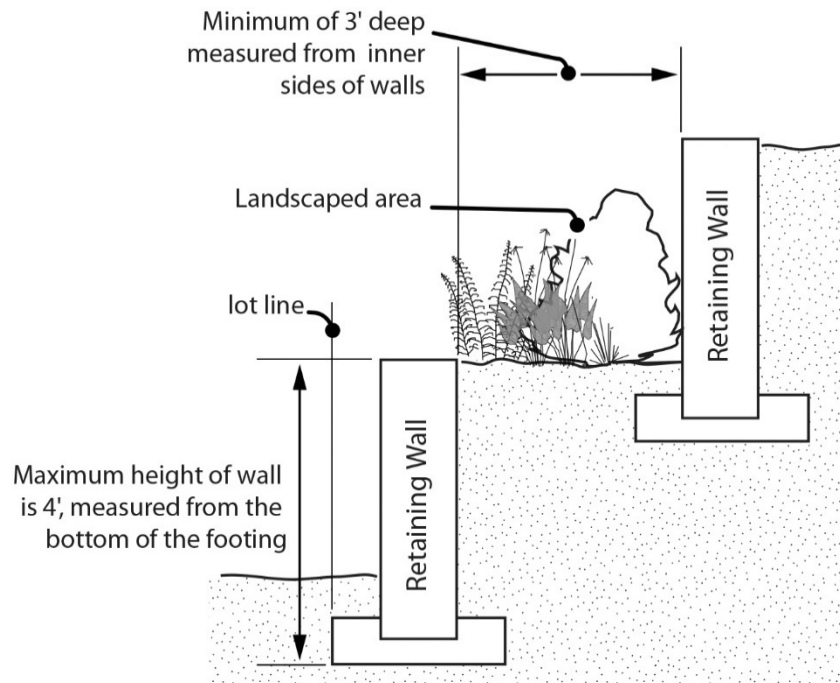

Commentary

33.110.292 Parking and Loading

The requirement for access from an alley when an alley exists and parking is proposed is being moved to 33.266.120.C and will apply to all houses, attached houses, duplexes and triplexes on lots that abut an alley. See page 147.

33.110.292275 ~~33.110.292275~~ **Parking and Loading**

For parking and loading regulations, see Chapter 33.266, Parking and Loading.

~~**A. Access to parking.** Vehicle access to a lot must be from an alley under the following conditions. Modifications to this standard are allowed through Planned Development Review. See Chapter 33.638, Planned Development. Adjustments are prohibited.~~

~~1. The lot abuts an alley;~~

~~2. The lot was created by a land division submitted after July 1, 2002; and~~

~~3. The lot is either:~~

~~a. In the R10 through R5 zones and does not meet the minimum lot width standard of 33.610.200.D.1; or~~

~~b. In the R2.5 zone and does not meet the minimum lot width standard of 33.611.200.C.1.~~

~~**B. Parking and loading.** For all other parking and loading regulations, see Chapter 33.266, Parking and Loading.~~

33.110.295280 ~~33.110.295280~~ **Signs**

The sign regulations are stated in Title 32, Signs and Related Regulations.

Commentary

33.205 Accessory Dwelling Units

Accessory dwelling units are currently allowed in conjunction with a house on any lot, but are not allowed in conjunction with a duplex. These changes allow for a second ADU in conjunction with a house, or a detached ADU in conjunction with a duplex.

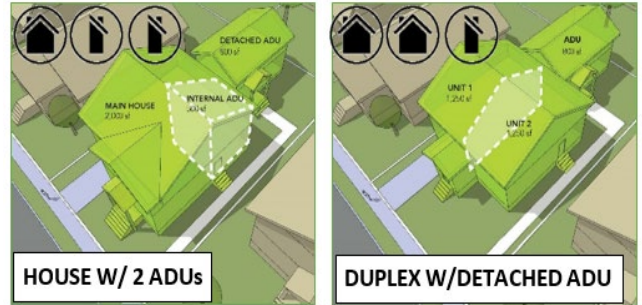

33.205.020.B.2

In the R7 - R2.5 zone, a larger lot size is required for the third unit (consistent with the standards for triplexes - 33.110.265.E)

Additionally, to avoid potential conflicts with the building code, only one ADU is allowed within a house and an ADU added to a duplex must be detached. Three units with one structure must be permitted as a triplex under the building code.

33.205 Accessory Dwelling Units

205

Sections:

- 33.205.010 Purpose
- 33.205.020 Where These Regulations Apply
- 33.205.030 General Requirements
- 33.205.040 Development Standards
- 33.205.050 Density

33.205.010 Purpose

Accessory dwelling units are allowed in certain situations to:

- Create new housing units while respecting the look and scale of single-dwelling development;
- Increase the housing stock of existing neighborhoods in a manner that is less intense than alternatives;
- Allow more efficient use of existing housing stock and infrastructure;
- Provide a means for residents, particularly seniors, single parents, and families with grown children, to remain in their homes and neighborhoods, and obtain extra income, security, companionship and services; and
- Provide a broader range of accessible and more affordable housing.

33.205.020 Where Accessory Dwelling Units are Allowed~~These Regulations Apply~~

~~An accessory dwelling unit may be added to a house, attached house, or manufactured home in an R, C, or EX zone except for attached houses in the R20 through R5 zones that were built using the regulations of 33.110.240.E, Duplexes and Attached Houses on Corners.~~

A. RF through R10. One accessory dwelling unit is allowed on a site with a house, attached house or manufactured home in the RF through R10 zones except for attached houses in the R20 and R10 zones that were built using the regulations of 33.110.265.C.1. In this case, an accessory dwelling unit is prohibited.

B. R7 through R2.5.

1. One accessory dwelling unit is allowed on a site with a house, attached house or manufactured home in the R7 through R2.5 zones when the lot complies with Section 33.110.202, Development on Lots and Lots of Record.
2. Up to two accessory dwelling units are allowed on a site with a house, attached house or manufactured home in the R7 through R2.5 zones when the lot meets the minimum lot area requirement stated in Table 205-1. If there are two accessory dwelling units on the site, only one may be attached to or within the primary structure.
3. One accessory dwelling unit is allowed on a site with a duplex in the R7 through R2.5 zones when the lot meets the minimum lot area requirements stated in Table 205-1. In this case, the accessory dwelling unit must be detached.

Commentary

Table 205-1

The lot size threshold for a site with 2 ADUs or a duplex and 1 ADU is that same as for required for a triplex or fourplex under the residential infill options n 33.110.265.

33.205.030.A. Number of residents.

The limitation on the number of residents on a site with an ADU is being deleted because the ADU size limitation serves to limit the number of people living in an ADU.

3

3.205.040.A. Development Standards Purpose Statement

The phrase "house, attached house, or manufactured home" is changed to "primary dwelling unit" to reflect that in some cases, ADUs are allowed with duplexes.

Language to be **added** is underlined
Language to be **deleted** is shown in ~~strikethrough~~

Zone	Minimum Lot Area
<u>R7</u>	<u>5,000 sq. ft.</u>
<u>R5</u>	<u>4,500 sq. ft.</u>
<u>R2.5</u>	<u>3,200 sq. ft.</u>

C. Multi-dwelling, C and EX.

1. Up to two accessory dwelling units are allowed on a site with a house, attached house or manufactured home in the multi-dwelling, C and EX zones. If there are two accessory dwelling units on the lot, only one may be attached to or within the primary structure.
2. One accessory dwelling unit is allowed on as site with a duplex in the multi-dwelling, C and EX zones. In this case, the accessory dwelling unit must be detached .

33.205.030 General Requirements

- ~~A. **Number of residents.** The total number of individuals that reside in both units may not exceed the number that is allowed for a household.~~
- ~~B. **Other uses.**~~
- ~~A.1-~~ Type B home occupation. An accessory dwelling unit is prohibited on a site with a Type B home occupation.
- ~~B.2-~~ Type A accessory short-term rental. An accessory dwelling unit is allowed on a site with a Type A accessory short-term rental.
- ~~C.3-~~ Type B accessory short-term rental. An accessory dwelling unit is allowed on a site with a Type B accessory short-term rental if the accessory dwelling unit meets the standards of Paragraph 33.815.040.B.1.

33.205.040 Development Standards

- A. Purpose.** Standards for creating accessory dwelling units address the following purposes:
- Ensure that accessory dwelling units are compatible with the desired character and livability of Portland’s residential zones;
 - Respect the general building scale and placement of structures to allow sharing of common space on the lot, such as driveways and yards;
 - Ensure that accessory dwelling units are smaller in size than primary dwelling units ~~houses, attached houses, or manufactured homes;~~ and
 - Provide adequate flexibility to site buildings so that they fit the topography of sites.
- B. Generally.** The development standards for accessory dwelling units are stated in this section. If not addressed in this section, the base zone development standards apply.

Commentary

33.205.040.C.1. Location of Entrances

The limitation on doors on the front façade of the house to provide greater flexibility and allow for easier conversion of existing spaces such as attached garages.

33.205.040.C.2. Maximum Size

These provisions are being amended to address size limits when an ADU is proposed with a duplex (i.e. a building with two primary units). This also clarifies that in these cases, the size of the ADU is tied to the smaller of the primary units to ensure that the ADU does not end up being larger than a primary unit.

A new provision is being added to recognize situations where a basement is being converted and where the basement is the same size as the house on the first floor. In these cases, the 75 percent/800 square foot size limit leads to either walling off area in the basement, designing it as common area for both units, or triggering the need for an adjustment. Since there is often little to no exterior difference, the impact is minimal. This, together with the 5 year time threshold, also serves as an incentive to adapt existing basement space as opposed to redeveloping the site.

33.205.040.C.3. Setbacks

This amendment clarifies that the ADU must be behind the rear building line as opposed to physically behind the house itself.

33.205.040.C.4.

With the addition of connected structures, clarification is added to address ADUs that are connected to the primary structure via a breezeway. A detached or connected ADU must meet the applicable height, setback, building coverage, and exterior design requirements for detached and connected covered accessory structures.

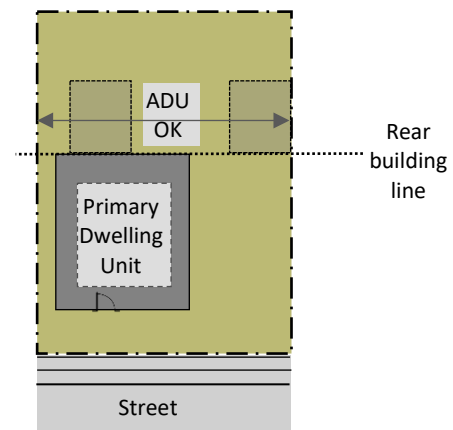

33.205.040.C.5 Visitability

These visitability requirements are being included to be consistent with the Residential Infill Options that require a visitable unit when there are 3 or more units are provided on a site (for example having two ADUs with a house, or one ADU with a duplex). See commentary on page 112.

C. Requirements for ~~all~~ accessory dwelling units. ~~All~~a Accessory dwelling units must meet the following:

- ~~1.~~ ~~Location of entrances. Only one entrance may be located on the facade of house, attached house, or manufactured home facing the street, unless the house, attached house, or manufactured home contained additional entrances before the accessory dwelling unit was created. An exception to this regulation is entrances that do not have access from the ground such as entrances from balconies or decks. Detached accessory dwelling units are exempt from this standard.~~
- ~~2~~1. Parking. No additional parking is required for the accessory dwelling unit. Existing required parking for the house, attached house, or manufactured home must be maintained or replaced on-site.
- ~~3~~2. Maximum size. The size living area of the accessory dwelling unit may be no more than 75 percent of the living area of the primary dwelling unit or 800 square feet of living area, whichever is less. This maximum size standard does not apply when the basement of a primary dwelling unit is converted to an accessory dwelling unit and the primary dwelling unit has been on the site for at least 5 years. The size measurements are based on what the square footage of the primary dwelling unit and accessory dwelling unit will be after the accessory dwelling unit is created. When the primary dwelling unit is a duplex, the size of the accessory dwelling unit may be no more than 75 percent of the living area of the smaller of the two primary units or 800 square feet of living area, whichever is less.
- ~~4~~3. Setbacks. Detached and connected accessory dwelling units must be:
 - a. Set back 40 feet from the front lot line; or
 - b. Located behind the rear building linewall of the primary dwelling unit~~house, attached house, or manufactured home~~. ~~For the purpose of this regulation, the rear wall of the house is the wall furthest from the wall with the main entrance to the street.~~
- ~~5~~4. Detached and connected accessory dwelling units must meet the development standards for ~~detached~~ covered accessory structures in the base zone.
5. Visitability.
 - a. Purpose. Visitability standards ensure that a baseline of accessible features is provided to accommodate people living in or visiting a residence regardless of age or ability. The standards:
 - Promote a diverse supply of more physically accessible housing;
 - Allow people of all ages and abilities to easily enter and visit the residence;
 - Foster community interaction by reducing barriers that can lead to social isolation; and
 - Enhance public safety for all residents and visitors.

Commentary

33.205.050 Density

This provision is being amended to allow accessory dwelling units to count toward the new minimum dwelling unit density requirement for double-sized lots in R2.5, R5, and R7 zones (see page 25).

- b. When the visitable unit standards apply. Unless exempted by Subparagraph C.5.c, the visitable unit standards apply to the following situations:
- (1) When there are two accessory dwelling units on a site with a house, attached house or manufactured home; and
 - (2) When there is one accessory dwelling unit on a site with a duplex.
- c. Visitable unit standards. At least one dwelling unit on the site must meet all of the following visitable unit standards:
- (1) Visitable entrance. At least one entrance must be provided with a route without stairs between the entrance and an on-site parking space or the street lot line. The slope of the route may not exceed 1:8.
 - (2) Visitable bathroom. At least one bathroom in the visitable unit must be designed to accommodate an unobstructed circle that is at least 60-inches in diameter. As an alternative, the bathroom may be designed to accommodate an unobstructed "t-shape" area that is comprised of two rectangles that are at least 36 inches by 60 inches, and oriented at right angles to each other. See Figure 205-1. The visitable bathroom must be on the same floor as the visitable entrance or be accessible from the visitable entrance via a ramp, elevator or lift. Adjustments are prohibited;
 - (3) Visitable living area. There must be at least 70 square feet of living area on the same floor as the visitable entrance or 70 square feet of living area must be accessible from the visitable entrance via a ramp, elevator or lift. Adjustments are prohibited; and
 - (4) Visitable doors. All door openings between the visitable entrance, visitable living area, and the visitable bathroom must be at least 34 inches wide. Adjustments are prohibited.

Figure 205-1
Visitable Bathroom Clearances

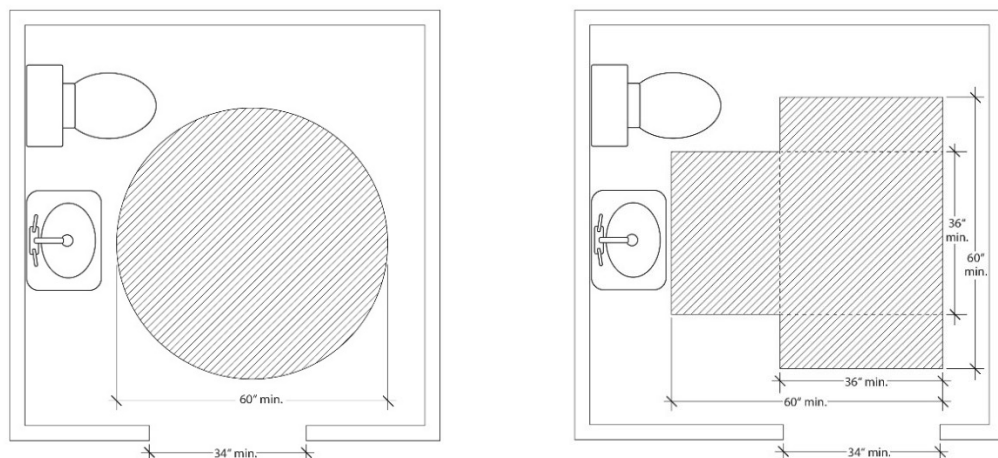

Commentary

d. Exemptions. The following are exempt from the visitable unit standards of this Paragraph:

- (1) Lots with an average slope of 20 percent or greater;
- (2) Lots where there is more than a 3-foot rise between the highest elevation along the street lot line and the lowest grade measured at the front setback.
- (3) Conversion of an existing accessory structure that is at least 5 years old or converting space in a house that is at least 5 years old to an accessory dwelling unit.

33.205.050 Density

~~In the single dwelling zones, accessory dwelling units are not included in the minimum or maximum density calculations for a site. In all other zones, a~~ Accessory dwelling units are included in the minimum density calculations, but are not included in the maximum density calculations.

Commentary

33.251.020.D

Several of the development standards for manufactured homes are being deleted to remove barriers to this type of housing. Manufactured homes are an affordable housing option and the development standards that are being deleted (minimum floor area, minimum roof pitch and required siding) all present barriers and can increase the cost of manufactured homes when adjustments are required to site a manufactured home that is less than 1000 square feet or has a roof pitch that is less than 3/12. In addition, conventionally built homes do not have similar requirements except in certain situations (design overlay zone or small flag lot) and deleting these standards will bring parity between the structure types.

33.251.020.D.2 Foundation

The foundation standard will remain because having a perimeter foundation is more in keeping with conventionally built houses, and having it enclosed helps improve energy efficiency by reducing heat loss. The standard is being amended because the specifications regarding the foundation (depth of excavation and back filling) are prescribed by building code.

33.251 Manufactured Homes and Manufactured Dwelling Parks

251

33.251.010 Purpose

This chapter provides standards ~~which will that~~ allow the placement of manufactured homes, mobile homes and manufactured dwelling parks in residential areas without changing the character of existing neighborhoods. These regulations promote additional housing options and provide locational opportunities for manufactured dwellings.

33.251.020 Manufactured Homes on Individual Lots

A.-B. [No change]

C. **Development standards.** Manufactured homes must meet the development standards of the base zone, except on individual lots in manufactured dwelling parks that were created under the provisions of Chapter 33.642.

D. **Other regulations.** Manufactured homes must meet the following standards:

- ~~1.~~ Floor area. ~~The manufactured home must be at least 1,000 square feet in floor area.~~
- ~~2.~~ Roof. ~~The manufactured home must have a pitched roof with a pitch of at least a nominal 3/12. The roof must be covered with shingles, shakes, or tile. Eaves from the roof must extend at least 1 foot from the intersection of the roof and the exterior walls.~~
13. Foundation. The manufactured home must be set on an excavated, back-filled a foundation that is and enclosed at the perimeter.
- ~~4.~~ Exterior siding. ~~The exterior siding of the manufactured home must have the same appearance as materials commonly used on residential dwellings. Metal siding must be painted or anodized.~~
25. Hauling mechanisms. The transportation mechanisms including the wheels, axles and hitch must be removed.

Commentary

33.266.110.B.2

Sites located close to transit are currently exempt from the minimum parking requirements. This amendment exempts sites in single-dwelling zones that are far from transit from the minimum parking requirements. Eliminating the parking requirement for household living uses has several benefits:

- Reducing required parking reduces the cost of building housing. Building a parking space cost on average \$3,000-20,000 per space.
- With the inclusion of a maximum FAR standard, eliminating the requirement that some of the floor area be devoted to a garage increases the amount of floor area that can be devoted to living space.
- Reducing the amount of parking required allows more of the site to be used for outdoor area, trees and landscaping.
- Eliminating parking requirement offers the opportunity for better site and building design because there may be less emphasis on accommodating vehicle storage.

33.266 Parking, Loading, And Transportation And Parking Demand Management

266

33.266.110 Minimum Required Parking Spaces

- A. [No change]
- B. **Minimum number of required parking spaces.**
1. Minimum for sites located close to transit. For sites located 1500 feet or less from a transit station, or 500 feet or less from a transit street with 20-minute peak hour service the following minimum parking requirements apply. The Bureau of Transportation will publish a map annually, adopted through Administrative Rule, showing sites that meet these service thresholds. For sites not shown on the map, the applicant may provide current information demonstrating that the site meets the service thresholds:
 - a. Household Living uses. The minimum number of required parking spaces for a site with a Household Living use is:
 - (1) Where there are up to 30 dwelling units on the site, no parking is required;
 - (2) Where there are 31 to 40 dwelling units on the site, the minimum number of required parking spaces is 0.20 spaces per dwelling unit;
 - (3) Where there are 41 to 50 dwelling units on the site, the minimum number of required parking spaces is 0.25 spaces per dwelling unit; and
 - (4) Where there are 51 or more dwelling units on the site, the minimum number of required parking spaces is 0.33 spaces per dwelling unit.
 - b. All other uses. No parking is required for all other uses.
 2. Minimum for sites located far from transit. For sites located more than 1500 feet from a transit station, or more than 500 feet from a transit street with 20-minute peak hour service the following minimum parking requirements apply:
 - a. Household Living uses.
 - (1) Single-dwelling zones. No parking is required for Household Living uses in the single-dwelling zones.
 - (2) All other zones. The minimum number of parking spaces required for Household Living uses in all other zones is stated in Table 266-1.
 - b. All other uses. ~~‡~~The minimum number of parking spaces required is stated in Table 266-1.
 3. [No change]

Commentary

33.266.120 Development Standards for Houses, Duplexes and Triplexes.

The existing parking standards are broken into two groups: standards for houses and duplexes and standards for all other development. These amendments group triplexes with houses and duplexes. Houses and duplexes have standards that allow for 9-foot wide driveways, backing out into the street, more restrictive front yard paving limits. Parking standards for fourplexes will continue to be grouped with the standards for all other development because accommodating 4+ parking spaces and maneuvering area introduces the need for requirements for forward entry and exiting, curbs, striping and screening.

33.266.120.A Purpose

The amendments to the parking regulations are intended to improve the pedestrian experience along streets.

33.266.120.C. Parking area locations

To reduce the prominence of vehicles in the front of residences, parking will be prohibited between the building and the street. Parking spaces will be allowed when they are either entirely behind the front building line (either in a garage or on a parking pad), or when they are located to the side of the building (i.e. not in the area between the building and the street). Driveways will only be allowed between an allowed parking space and the street.

Where the parking is proposed on the site to the side of a building the parking space must be outside the first 10 feet or street side setback. Parking in the first 10 feet is only allowed when it is directly behind another space that is located entirely outside the 10-foot area.

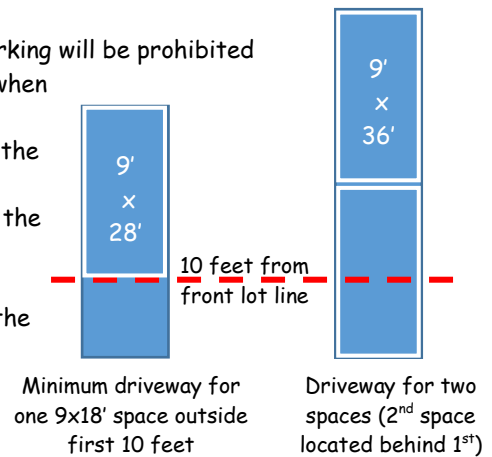

Paving in the front yard is limited to 40% (20% on a street side yard), except for flag lots which can have a 12-foot-wide driveway (otherwise the 40% limit would mean a maximum 4.8 foot wide driveway on a 12 foot wide pole).

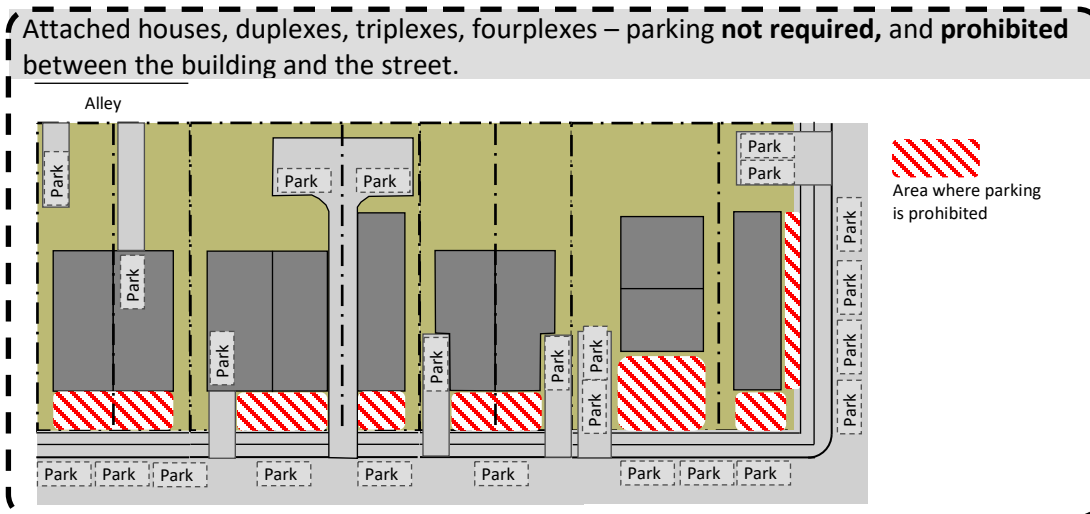

33.266.120 Development Standards for Houses, ~~and Duplexes, and Triplexes~~

- A. Purpose.** The size and placement of vehicle parking areas are regulated in order to enhance the appearance and pedestrian experience of neighborhoods.
- B. Structures these regulations apply to.** The regulations of this section apply to houses, attached houses, duplexes, attached duplexes, triplexes, manufactured homes, and houseboats. The regulations apply to all required ~~and excess~~ parking areas. The following are exceptions to this requirement:
1. Parking that is in a parking tract is subject to the standards of Section 33.266.130 instead of the standards of this section. However, perimeter landscaping is not required where the parking tract abuts a lot line internal to the site served by the tract.
 2. Parking for manufactured dwelling parks is regulated in Chapter 33.251.
- C. Parking area locations.**
1. Vehicle area. The following standards apply to the location of vehicle area:
 - a. Vehicle area is prohibited between the primary structure and the street except as follows. This standard does not apply to houses on lots that are at least 32 feet wide:
 - (1) Parking spaces located entirely behind the front and side street building lines of a primary structure are allowed; and
 - (2) Driveways to parking spaces located entirely behind the front and side street building lines of a primary structure are allowed.
 - b. No more than 40 percent of the land area between the front lot line and the front building line may be paved or used for vehicle areas. See Figure 266-2. On corner lots, no more than 20 percent of the land area between the side street lot line and the side street building line may be paved or used for vehicle areas. For attached houses, this standard applies to the combined lot lines of attached house lots. As an exception to the area limitations in this subparagraph, a flag lot with a pole that allows vehicle access is allowed at least a 12-foot wide vehicle area.
 2. Parking spaces. The following standards apply to the location of parking spaces:
 - a. Generally, parking spaces are not allowed within the first 10 feet from a front lot, and on corner lots, parking spaces are not allowed within the side street setback.
 - b. Exceptions. A parking space is allowed within the first 10 feet from a front lot line or within a side street setback when the parking space is in a driveway behind a parking space that is located outside of the first 10 feet from a front lot line or outside of the side street setback.

Commentary

C.3. Alley access

This amendment requires parking to be accessed via an alley when an alley exists, and parking is proposed. Alley-loaded parking is an optimal parking solution where alleys are present. It preserves the street-facing side of the house for landscaping and more interesting architectural details, retains area for street trees, eliminates curb cuts and reduces conflicts with pedestrians. This is not a requirement to improve an unimproved alley because on-site parking will no longer be required.

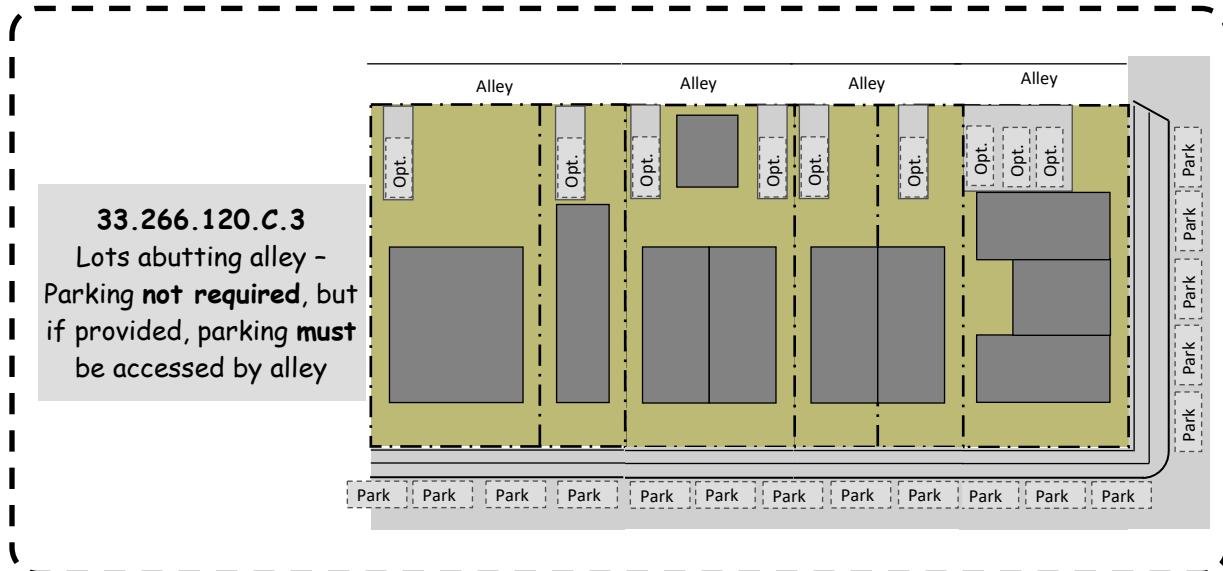

Example of a garage built adjacent to an alley but does not use the alley for access. This removes on street parking, limits street trees and creates a very wide curb cut zone. This will no longer be allowed.

3. Vehicle area access. If the lot abuts an alley, all parking and vehicle access to the site must be from the alley.

~~1. Required parking~~

~~a. Generally, Required parking spaces are not allowed within the first 10 feet from a front lot line or in a required front setback, whichever is greater. In addition, on corner lots, required parking spaces are not allowed within the side street setback.~~

~~b. Exception for common greens and shared courts. On lots where the front lot line abuts a common green or shared court, parking spaces are allowed within 10 feet of the front lot line.~~

~~2. Non-required parking. Where non-required parking is provided on a site, at least one parking space (required or not required) must meet the standards for required parking stated in Paragraph C.1 above. A non-required parking space is allowed within the first 10 feet from a front lot line or in a required front setback if it is in a driveway immediately behind a required parking space (See Figure 266-1, Non-Required Parking). On a corner lot, where the driveway is in the required side setback, a non-required space is allowed within the first 10 feet from the side street lot line or in the required side setback if it is in a driveway immediately behind a required parking space.~~

~~3. Front yard restrictions.~~

~~a. No more than 40 percent of the land area between the front lot line and the front building line may be paved or used for vehicle areas. In addition, on corner lots, no more than 20 percent of the land area between the side street lot line and the side street building line may be paved or used for vehicle areas. See Figure 266-2. As an exception to the area limitations in this subparagraph the following is allowed:~~

~~(1) A lot is allowed at least a 9-foot wide vehicle area.~~

~~(2) In the multi-dwelling, C, E, I, CI, and IR zones, on sites where the front lot line abuts a shared court, paving blocks or bricks may be used to surface the entire area between the front lot line and the front building line.~~

~~b. For flag lots, where the width of the pole is greater than 30 feet, no more than 40 percent of the land area between the front lot line and the front building line may be paved or used for vehicle areas.~~

~~See Figure 266-2. As an exception to the area limitation of this subparagraph, a flag lot is allowed at least a 12-foot wide vehicle area.~~

4. Parking in garages. Parking in garages is subject to the garage setback standards of the base zone, overlay zone or plan district.

D.-E. [No change]

Commentary

Figure 266-1

With the changes to eliminate minimum required parking for houses, duplex, and triplexes in single dwelling zones, the figure delineating the distinction between required and non-required parking is being replaced to instead illustrate where parking spaces are/are not allowed.

Language to be **added** is underlined
Language to be **deleted** is shown in ~~strikethrough~~

Figure 266-1
Non-Required Parking

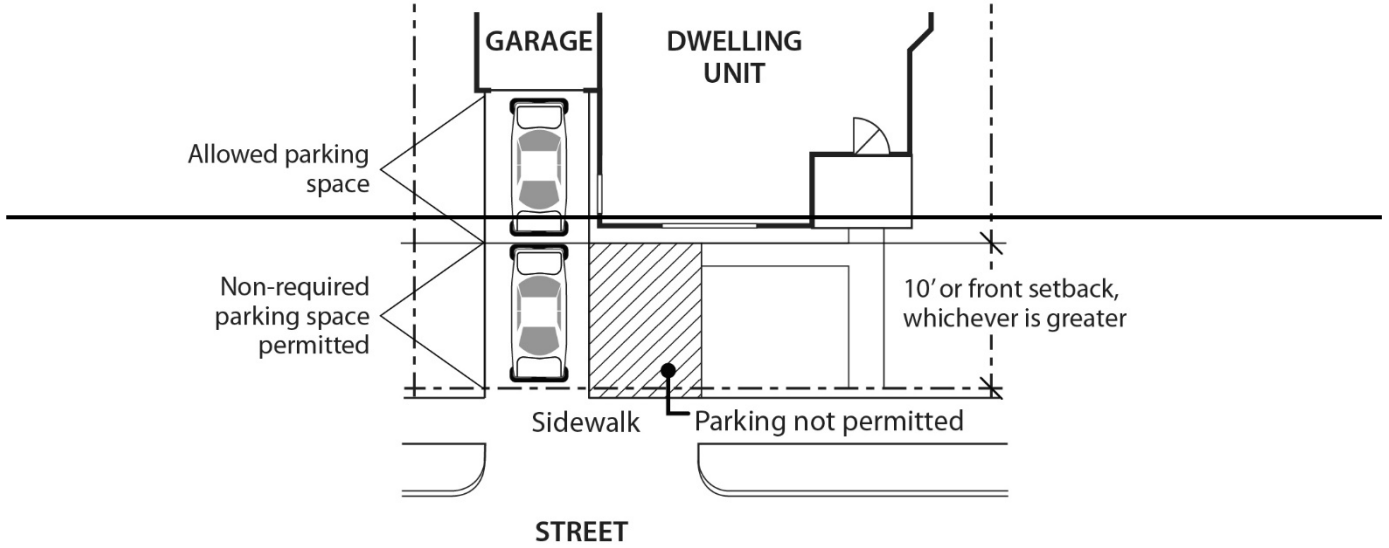
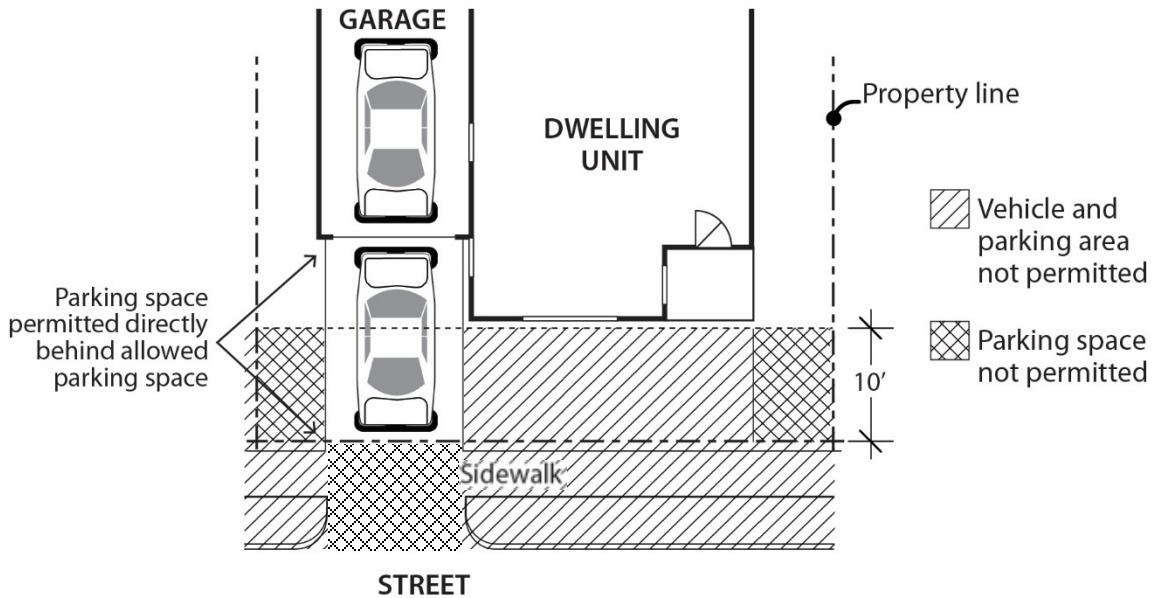

Figure 266-1
Parking Space Locations



Commentary

33.266.130 Development Standards for all other development

B. Where the standards apply. This was amended to refer to vehicle areas more broadly, not just parking locations. Vehicle areas refers to all the area on a site where vehicles may circulate or park including parking areas, driveways, drive-through lanes, and loading areas.

33.266.130.C.1. Location of vehicle area

A change is being made to align with upcoming changes as part of the Better Housing by Design Project which is proposing requiring alley access for ≤ 7500 square foot sites in multi dwelling zones. This also aligns fourplex parking requirements with changes being made for houses, duplexes, and triplexes on alley lots (see 33.266.120.C.3)

33.266.130.C.3 Frontage limitation

The R7, R5, and R2.5 zones are included here to address parking and vehicle areas that are not associated with a house, duplex or triplex. Specifically, this will apply to fourplexes, but will also be applied to non-conforming and conditional uses (schools, religious institutions, etc). This limits front yard vehicle area to 50%. Note: the Better Housing by Design Project includes changes to this section that will align the frontage limitation to the 40% limit for houses, duplexes and triplexes..

33.266.130 Development Standards for All Other Development

- A. [No change]
- B. **Where these standards apply.** The standards of this section apply to all vehicle areas whether required or excess parking, except for residential ~~parking~~vehicle areas subject to the standards of 33.266.120.
- C. **On-site locations of vehicle areas.**
1. Location of vehicle areas. The allowed on-site location of all vehicle areas is stated in Table 266-3. Additionally, on sites in single dwelling zones that abut an alley and are 7,500 square feet or less in area, all parking and vehicle access to the site must be from the alley.
 2. Building setbacks for structures that contain vehicle areas.
 - a. Structures that contain vehicle areas are subject to the building setbacks of the base zone, where exiting in a forward motion is provided.
 - b. Structured parking that does not allow exiting in a forward motion in R Zones is subject to the garage entrance setback standard of the base zone.
 - c. Structured parking that does not allow exiting in a forward motion in C, E, I, CI, or IR zones must be set back 18 feet from the street lot line.
 3. Frontage limitation.
 - a. The standard of this subparagraph applies outside the Central City plan district in the R7, R5, R2.5, R3, R2, R1, and RMP zones. No more than 50 percent of the frontage on a street may be used for vehicle areas. On sites with more than one street frontage, this standard applies to the street with the highest transit designation. If two streets have the same highest transit classification, the applicant may choose on which street to meet the standard. Sites where there is less than 100 square feet of net building area are exempt from this standard.
 - b. The standard of this paragraph applies outside the Central City plan district in the RH, RX, CR, CM1, CM2, CM3, CE, CX, EG1, EX, CI, and IR zones. Where vehicle areas are adjacent to a transit street or a street in a Pedestrian District, no more than 50 percent of the frontage on the transit street or street in a Pedestrian District may be used for vehicle areas. Sites where there is less than 100 square feet of net building area are exempt from this standard.

Commentary

Table 266-3

The amendments to Table 266-3 apply the vehicle area location standards for the RX, CX, CR, EX and smaller CM1-CM3 zones to the R7, R5, and R2.5 zones so that the vehicle area location standards for fourplexes (and other non-Household Living uses) are similar to the vehicle area location standards for houses, duplexes and triplexes.

Language to be **added** is underlined
 Language to be **deleted** is shown in ~~strikethrough~~

D. Improvements.

1. Paving. In order to control dust and mud, all vehicle areas must be paved. However, some portions of individual parking spaces may be landscaped per the standards of Paragraph F.4, below.
2. Striping. All parking areas, except for stacked parking, must be striped in conformance with the parking dimension standards of Subsection F. below.
3. Protective curbs around landscaping. All perimeter and interior landscaped areas must have protective curbs along the edges. Curbs separating landscaped areas from parking areas may allow stormwater runoff to pass through them. Tire stops, bollards, or other protective barriers may be used at the front ends of parking spaces. Curbs may be perforated or have gaps or breaks. Trees must have adequate protection from car doors as well as car bumpers.

E.-G. [No change]

Table 266-3 Location of Vehicle Areas [1]			
Zone	General Standard	Exception for Through Lots and Sites with Three Frontages	Exception for Full-Block Sites
OS, RF-R10R5, R2.5, EG2, I	No restrictions.		
R3, R2, R1, RH, RMP, IR, CE, EG1, CI, sites in CM1, CM2, and CM3 that are more than 2 acres in total area	Vehicle areas not allowed between the portion of the building that complies with the maximum street setback and the transit street or streets in a Pedestrian District.	May have vehicle areas between the portion of the building that complies with the maximum street setback and one Local Service Transit Street.	May have vehicle areas between the portion of the building that complies with the maximum street setback and two Local Service Transit Streets.
<u>R7-R2.5</u>, RX, CX, CR, EX, sites in CM1, CM2, and CM3 that are 2 acres or less in total area	Not allowed between a building and any street.	May have vehicle areas between the building and one Local Service Transit Street.	May have vehicle areas between the building and two Local Service Transit Streets.

Notes:

[1] Driveways that provide a straight-line connection between the street and a parking area inside a building are not subject to these regulations.

Commentary

33.270.020.B.1 Density and FAR.

These amendments are intended to more closely align the new housing allowances in the R7-R2.5 zones with the allowed density in the Planned Development regulations. For example, if 5 lots in the R5 zone could each have 4 dwelling units (i.e. a fourplex per lot) with a total of 20 units among the 5 lots, then a similarly sized planned development site should likewise be allowed 20 units. The Planned Development review provides for flexibility in how dwelling units are arranged (i.e. a mixture of different housing types) while ensuring compatibility with the surrounding area. The density calculation for Planned Developments in the R7, R5 and R2.5 zones have been revised to allow for a system of near equivalency between the number of dwelling units allowed on a site that is divided through a land division and one that is not divided but is designed through a Planned Development review.

For the R7 and R5 zones, the maximum number of dwelling units allowed for a site that is not in the Constrained Sites overlay zone or otherwise prohibited from having a triplex or fourplex will be 4 times the base zone density standard. This maximum number of dwelling units is based on the fact that the average lot sizes in the R7 and R5 zones are larger than the minimum lot size required to build a triplex/fourplex in the zones (R7 average lot size = 1/7,000 sq. ft., min lot size for a triplex/fourplex = 5,000 sq. ft.; R5 average lot size = 1/5,000 sq. ft., minimum lot size for a triplex/fourplex = 4,500 sq. ft.).

33.270 Planned Development

270

Sections:

- 33.270.010 Purpose
- 33.270.020 Relationship to Other Regulations
- 33.270.100 Additional Allowed Uses and Development in ~~Single Dwelling Zones~~
- 33.270.110 Limitations on Residential Uses and Development
- 33.270.200 Additional Requirements for Planned Developments in R7 and R5 zones
- ~~33.270.200~~210 Additional Requirements for Planned Developments in Commercial/Mixed Use Zones

33.270.020 Relationship to Other Regulations

- A. Flexibility.** Approval of a Planned Development allows certain kinds of flexibility for development in residential zones and commercial/mixed use zones. Some of the flexibility allowed by Planned Developments may also be allowed under other provisions of this Title. Where such situations exist, the applicant may choose which provision to apply.
- B. Density and FAR.** ~~Adjustments to density and FAR regulations are prohibited. Minimum residential density and minimum FAR requirements must be met in a Planned Development. Adjustments to minimum density or minimum FAR are prohibited. Where the density requirement is expressed as a number of lots, it can be met in the Planned Development by providing the same number of dwelling units. Maximum density requirements in Single Dwelling zones are specified in 33.610.100 and 33.611.100. Maximum FAR requirements are specified in 33.130.205.~~

1. Density.

a. Maximum dwelling unit density.

(1) RF through R10. In RF through R10, maximum density is expressed as a number of lots. Maximum density can be met in the Planned Development by providing the same number of dwelling units. Maximum density for the RF through R10 zones is specified in 33.610.100.

(2) R7 and R5:

- If the Planned Development is in the Constrained Sites Overlay or does not qualify to use the triplex or fourplex provisions of 33.110.265.E, maximum density is expressed as a number of lots. Maximum density can be met in the Planned Development by providing the same number of dwelling units. Maximum density for the R7 and R5 zones is specified in 33.610.100.
- For all other Planned Developments, maximum density is expressed as a number of dwelling units and is calculated as follows:
Square footage of site;
÷ Maximum density from Table 610-1;
x 4
= Maximum number of dwelling units allowed.

Commentary

33.270.020.B.1.a(3) R2.5

The maximum number of dwelling units allowed through a Planned Development in the R2.5 zone will be twice the base zone density rather than four times the base zone density as in the R7 and R5 zones. This is because the average lot size for a triplex or fourplex in the R2.5 zone is smaller than the minimum lot size required to build a triplex/fourplex on a lot in this zone (R2.5 average lot size = 2,500 sq. ft., minimum lot size for a triplex/fourplex = 3,200 sq. ft.). Allowing up to four times the number of dwelling units on a Planned Development site in this zone would result in more dwelling units than would be allowed if the site was divided through a land division.

33.270.020.B.2.FAR

In the R7 - R2.5 zones, the FAR increases with the number of units on a single lot. Table 110-4 specifies different FARs for lots and sites with 1, 2 and 3 or more units. When multiple units are proposed for a single site, the higher FARs will apply.

C. Land Divisions

This amendment reiterates that the number of lots that can be created through a Land Division

(3) R2.5

- If the Planned Development is in the Constrained Sites Overlay or does not qualify to use the triplex or fourplex provisions of 33.110.265.E, maximum density is expressed as a number of lots. Maximum density can be met in the Planned Development by providing the same number of dwelling units. Maximum density for the R2.5 zone is specified in 33.611.100.
- For all other Planned Developments, maximum density is expressed as a number of dwelling units and is calculated as follows:

Square footage of site;

÷ 2,500;

x 2

= Maximum number of dwelling units allowed.

- b. Minimum density. Minimum density must be met in the Planned Development. Minimum density for single-dwelling zones is expressed as a number of lots. Minimum density can be met in a Planned Development by providing the same number of dwelling units. Minimum density for single-dwelling zones is stated in 33.610.110 and 33.611.100. Minimum density for all other zones is stated in the base zone chapters.

2. FAR.

a. Maximum FAR.

- (1) R7 through R2.5. The maximum FAR in the R7 through R2.5 zones is specified in 33.110.210.
- (2) Commercial/mixed use zones. The maximum FAR in the commercial/mixed use zones is specified in 33.130.205.

- b. Minimum FAR. Where the base zone requires a minimum FAR, the standard must be met in a Planned Development

- C. **Land Divisions.** A Planned Development may be the only land use review requested for a site, or may be part of a proposal for a Land Division. Certain site conditions or aspects of a proposal require a Land Division, including situations where a tract is required (such as when there is floodway on the site), or where rights-of-way are requested or required. Maximum dwelling unit density in a Planned Development does not equate to maximum lot density in a Land Division.

Commentary

33.270.100.D Triplexes and E. Fourplexes

This amendment identifies triplexes and fourplexes as being allowed housing types through a Planned Development because triplexes and fourplexes will be stand-alone housing types—they were previously covered under the definition of multi-dwelling structure (see page 227). The housing type multi-dwelling structures will now be defined as buildings with five or more dwelling units.

33.270.100.I Alternative Residential Dimensions

This flexibility allows the minimum lot dimensions for new lots to be modified through a Planned Development. Currently, in the single-dwelling zones the dimensions that can be modified are minimum lot area, depth and front lot line. Whereas all of the minimum lot dimensions standards for new lots in multi-dwelling zones may be modified through a PD. This amendment will allow lot width and maximum lot area to be modified through a PD in the single-dwelling zones because chapters 33.610 and 33.611 both currently say lot width can be modified through a PD.

33.270.100 Additional Allowed Uses and Development

In addition to the housing types and uses allowed by other chapters of this Title, the following uses and development may be requested through Planned Development Review. More than one of these elements may be requested:

- A. Attached houses.** Attached houses may be requested in the RF through R5 zones;
- B. Duplexes.** Duplexes may be requested in the RF through R2.5 zones;
- C. Attached duplexes.** Attached duplexes may be requested in the RF through R2.5 zones;
- D. Triplexes.** Triplexes may be requested in the RF through R2.5 zones;
- E. Fourplexes.** Fourplexes may be requested in the RF through R2.5 zones;
- FD. Multi-dwelling structures.** Multi-dwelling structures may be requested in the RF through R2.5 zones;
- GE. Multi-dwelling development.** Proposals to allow multi-dwelling development on a lot may be requested in RF through R2.5 zones;
- HF. Modification of site-related development standards.** Modification of site-related development standards that are not prohibited from being adjusted may be requested through a Planned Development.
- IG. Alternative residential dimensions.** ~~Proposals for lots that do not meet the minimum lot area, minimum lot depth, or minimum front lot line standards may be requested in RF through R2.5 zones.~~ Proposals for lots that do not meet the minimum lot size dimensions regulations for land divisions may be requested in the RF through RH through R3 zones.
- JH. Commercial uses.** Commercial uses that are allowed in the CM1 zone may be requested in the RF through R1 zones;
- KI. Additional height and FAR.** For sites in the CM2, CM3, CE, and CX zones outside of the Central City and Gateway plan districts that are greater than 2 acres in size, additional height and FAR may be requested through a Planned Development as specified in 33.130.212.E, Planned Development Bonus, and Table 130-3;
- LJ. Transfer of development within a site.** Transfer of development rights across zoning lines within the site may be proposed as follows:
 - 1. RF through R1 zones. If the site is located in more than one zone, and all the zones are RF through R1, the total number of units allowed on the site is calculated by adding up the number of units allowed by each zone. The dwelling units may be placed without regard to zone boundaries.
 - 2. RH and RX zones. If the site is located in more than one zone, and the zones are RH and RX, the total amount of floor area allowed on the site is calculated by adding up the amount of floor area allowed by each zone. The floor area may be placed without regard to zone boundaries.
 - 3. C, E, I, CI, and IR zones. If the site is located in more than one zone, and all the zones are C, E, I, CI, and IR zones, the total amount of floor area allowed on the site is calculated by adding up the amount of floor area allowed by each zone. The floor area may be placed without regard to zone boundaries.

Commentary

33.270.100.M. Transfer of Development between Sites

This amendment clarifies that this regulation only applies when the transfer of development rights (which are described in other chapters) requires a Planned Development. For example, the density transfer allowed in the Johnson Creek Basin plan district requires a PD, whereas the FAR transfer from an historic site in the Mixed-Use zones does not. There has been an ongoing misunderstanding that this subsection requires a PD for every density or FAR transfer

33.270.200 Additional requirements for Planned Developments in the R7 and R5 zones

As part of aligning Planned Developments with Land Divisions in the R7-R5 zones, the visitability requirements are similarly applied when there are at least 3 units proposed on a site. One-third of the units will need to meet the visitability standards. An exemption is provided for steeply sloping sites. An exemption is also provided for PDs with a concurrent land division. In these cases, if the new lots will be developed with triplexes or fourplexes, they will be subject to the visitability standards and exemptions specified in the Residential Infill Options.

R2.5 zones are not included, since the density calculations (33.270.020.B.1.a(3)) only double the unit allowance.

See commentary related to visitability requirements on page 112.

4. All zones. If the site is located in more than one zone, and at least one of the zones is RF through R1, and at least one of the zones is RH, RX, C, or EX, then the total number of dwelling units allowed on the site is calculated as follows:
 - a. The number of units allowed on the RF through R1 portion of the site is calculated in terms of dwelling units;
 - b. The number of units allowed on the other portion of the site is calculated in terms of floor area; The floor area calculation is converted to dwelling units at the rate of 1 dwelling unit per 1,000 square feet of floor area;
 - c. The two dwelling unit numbers are added together, and may be placed without regard to zone boundaries.

MK. **Transfer of development between sites.** Sites that are eligible to transfer development rights to another site are designated in other chapters of this Title. Where such transfers require a Planned Development~~€€€€~~, both the sending and receiving sites must be part of a Planned Development.

33.270.110 Limitations on Residential Uses and Development

The following limitations apply to Planned Developments proposed in EG or I Zones:

- A. Industrial zones.** Residential uses and development are prohibited in industrial zones. Using floor area transferred from industrial zones for residential uses is prohibited in all zones.
- B. EG1 and EG2 zones.** Residential uses and development are prohibited in EG1 and EG2 zones. Using floor area transferred from EG1 or EG2 zones for residential uses is prohibited in all zones.

33.270.200 Additional requirements for Planned Developments in the R7 and R5 Zones

In the R7 and R5 zones, unless exempted by Subsection B., when the total number of proposed dwelling units is at least 75 percent of the maximum number of dwelling units allowed through the Planned Development, at least 33 percent of the dwelling units on the Planned Development site must be visitable. VISIBLE means that the unit meets the visitability standards specified in Subsection A.

A. Visitability standards:

1. VISIBLE entrance. At least one entrance must be provided with a route without stairs between the entrance and an on-site parking space or the street lot line. The slope of the route may not exceed 1:8.
2. VISIBLE bathroom. At least one bathroom in the visitable unit must be designed to accommodate an unobstructed circle that is at least 60-inches in diameter. As an alternative, the bathroom may be designed to accommodate an unobstructed "t-shape" area that is comprised of two rectangles that are at least 36 inches by 60 inches, and oriented at right angles to each other. See Figure 270-1. The visitable bathroom must be on the same floor as the visitable entrance or be accessible from the visitable entrance via a ramp, elevator or lift. Adjustments are prohibited;
3. VISIBLE living area. There must be at least 70 square feet of living area on the same floor as the visitable entrance or 70 square feet of living area must be accessible from the visitable entrance via a ramp, elevator or lift. Adjustments are prohibited; and
4. VISIBLE doors. All door openings between the visitable entrance, visitable living area, and the visitable bathroom must be at least 34 inches wide. Adjustments are prohibited.

Commentary

33.270.200.B. Exemptions

The exemptions for the visitability requirement include steeply sloping sites (same as base zone, and ADU requirements), proposals when there are fewer than 3 units (for example a PD for a duplex or two single houses on a site), and proposals that also include a land division to create lots for subsequent building (as these would be treated like other lots where 3 or 4 units are proposed).

B. Exemptions. The following are exempt from the standards of Subsection A:

1. Sites with an average slope of 20 percent or greater
2. Sites where fewer than 3 units are proposed.
3. Sites with a concurrent land division where no multi-dwelling development or multi-dwelling structures are proposed. For these sites, the visitability standards are applied to each lot according to 33.110.265.E.3. at the time of development

Figure 270-1
Visitable Bathroom Clearances

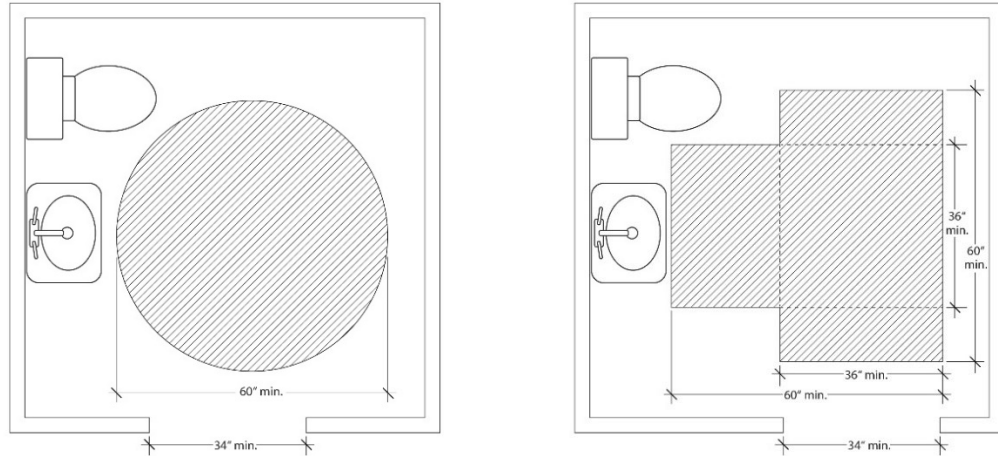

33.270.200210 Additional Requirements for Planned Developments in the Commercial/Mixed Use Zones

Planned Developments in the CM2, CM3, and CE zones, and in the CX zone outside the Central City and Gateway plan districts, that are using the Planned Development bonus, must met all of the following requirements:

A.-D. [No change]

Commentary

33.281 Schools and School Sites

281

33.281.100 General Standards

In the OS, R, and R zones, the development standards for institutional uses apply except where superseded by the standards in this chapter. The institutional development standards are stated in 33.110.~~270~~245 and 33.120.275. In C and E zones, the development standards of the base zone apply except where superseded by the standards in this chapter. Recreational fields used for organized sports are subject to Chapter 33.279, Recreational Fields for Organized Sports.

Commentary

Overlay Zones

- 33.400 Aircraft Landing Zone – h
- 33.405 Alternative Design Density Overlay Zone – a
- 33.410 Buffer Zone – b
- 33.415 Centers Main Street Overlay Zone – m
- 33.418 Constrained Sites Overlay Zone – z
- 33.420 Design Overlay Zone – d
- 33.430 Environmental Zone – c or p
- 33.435 Future Urban Zone – f
- 33.440 Greenway Zones – g, i, n, q, or r
- 33.445 Historic Resource Protection Overlay Zone
- 33.465 Pleasant Valley Natural Resources Overlay Zone – v
- 33.470 Portland International Airport Noise Impact Zone – x
- 33.471 Prime Industrial Overlay Zone – k
- 33.475 River Overlay Zones – g*, e
- 33.480 Scenic Resource Zone – s

A list of symbols that appear on the Official Zoning Maps and their corresponding Zoning Code chapters is contained in the front of the Zoning Code, following the Table of Contents, under “Index of Symbols on the Official Zoning Maps”.

Commentary

33.405 Alternative Density Design overlay zone

This map shows the location and extent of the current a-overlay as applied to single dwelling zoned areas. The a overlay is being removed from single dwelling zones because for all intents and purposes, the additional housing allowances that are available in the a overlay zone will be available going forward in the base zones. These allowances include attached houses on narrow lots in the R5 zone, triplexes on 4,800 square foot lots in the R2.5 zone, and flag lots in the R2.5 zone.

Design review or meeting community design standards was required for all proposals using these provisions. Between 1995 and 2016 there were approximately 6,000 permits for alterations or new construction for the approximately 45,000 lots in the a overlay. Staff estimates that fewer than 250 properties (roughly 0.5 percent) used provisions of the a' overlay.

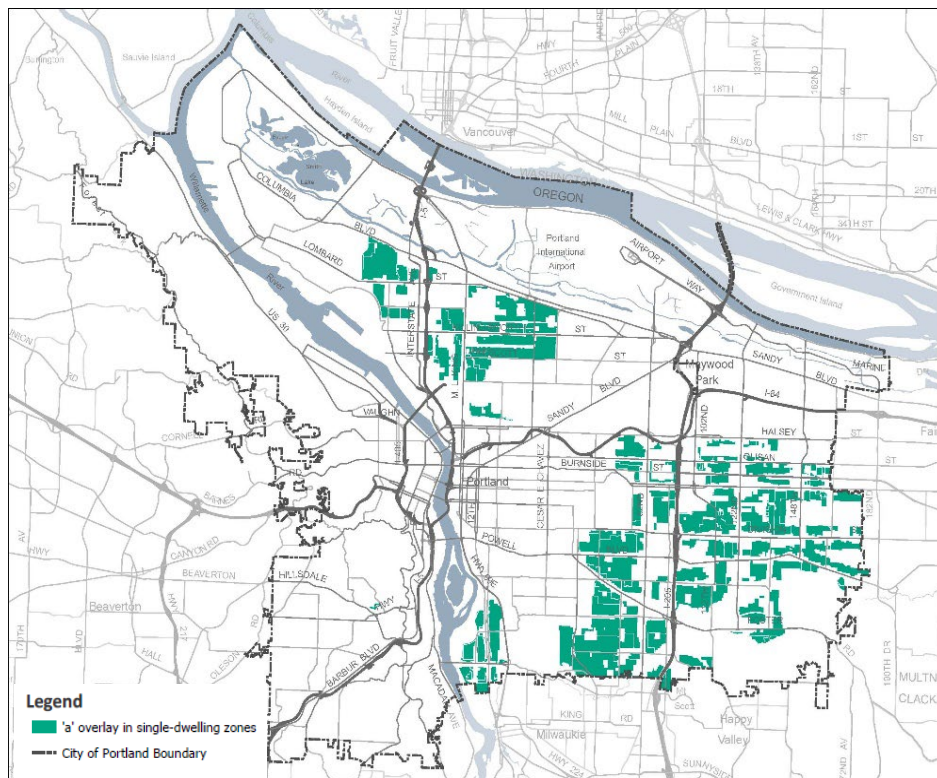

33.405 Alternative Design Density Overlay Zone

405

Sections:

General

- 33.405.010 Purpose
- 33.405.020 Short Name and Map Symbol
- 33.405.030 Applying the Alternative Design Density Overlay Zone

Development Standards

- 33.405.050 Bonus Density for Design Review
- ~~33.405.060 Attached Houses on Vacant Lots in the R5 Zone~~
- 33.405.070 Alternative Development Options in the R2 ~~and R2.5~~ Zones
- 33.405.080 Nonconforming Multi-Dwelling Housing
- 33.405.090 Design Review and Community Design Standards
- 33.405.100 Review for Timeliness

~~33.405.060 Attached Houses on Vacant Lots in the R5 Zone.~~

- ~~**A. Purpose.** The increased density permitted by this section encourages infill development in areas that are generally well served by existing public services. The increase allows the area to absorb additional growth without creating market pressure that might lead to the early removal of existing sound housing. The increased density will lower the cost of housing while increasing opportunities for owner-occupied housing. Required design review of new development ensures that the new housing will make a positive contribution to the neighborhood's character.~~
- ~~**B. Attached houses.** Attached houses are allowed in the R5 zone if all of the following are met. Adjustments to this section are prohibited:~~
- ~~1. The proposed attached housing development will be on a lot or lot of record that was created at least five years ago;~~
 - ~~2. There has not been a dwelling unit on the lot or lot of record for at least five years;~~
 - ~~3. The density requirements of Chapter 33.611 must be met, and each attached house must be on a lot that meets the lot dimension standards of Chapter 33.611;~~
 - ~~4. Attached houses must meet the following development standards:~~
 - ~~a. Height and front setback standards. Attached houses must meet the height and front setback standards of the R5 zone; and~~
 - ~~b. All other development standards. The attached house must meet all other development standards for attached housing projects in the R2.5 zone;~~

Commentary

~~5. Design review required:~~

- ~~a. Generally. Attached residential development must be approved through design review or meet the Community Design Standards in Chapter 33.218, as set out in Section 33.405.090, Design Review and Community Design Standards, below; and~~
- ~~b. Exception. If the site is a Historic or Conservation Landmark, or in a Historic or Conservation District, it is subject to the regulations for historic resource review as set out in Chapter 33.445, Historic Resource Overlay Zone.~~
- ~~c. Land Division. If the proposal requires, or the applicant requests, a land division, the application for the land division must show how the Community Design Standards are met. If the Community Design Standards cannot be met or the applicant chooses not to meet the Community Design Standards, design review is required. When design review is required, the design review process must be concurrent with the land division. The Community Design Standards must be met or design review must be approved in order for the land division to be approved.~~
- ~~d. Changes to a design approved concurrently with a land division. If the design of the proposed development was reviewed concurrently with the land division through design review, changes to the design of the proposed development after final plat approval must be reviewed through design review. If the proposed development met the Community Design Standards concurrently with the land division, changes to the design of the proposal after final plat approval must continue to meet the Community Design Standards, or must be reviewed through design review. Concurrent land division review is not required to change the design of the proposed development after final plat approval.~~

33.405.070 Alternative Development Options in the R2 and ~~R2.5~~ Zones

- A. Purpose.** The provisions of this section offer opportunities for enhancing the variety of housing types and building forms that are found in areas zoned for ~~attached~~ or low-density multi-dwelling residential development. Such areas generally include a mixture of single-dwelling detached and small multi-dwelling development. A variety of types of housing in areas receiving infill development will improve continuity with the character of the existing buildings.
- B. Triplex.** Triplexes are allowed, if they meet all the following requirements:
 - 1. The proposed development conforms with the maximum height, minimum setbacks, maximum building coverage, and required outdoor area requirements for ~~attached housing~~ projects in the R2.5 zone. The proposed development must meet all other development standards of the base zone, overlay zone, and plan district; and
 - 2. The maximum density allowed under this provision is one dwelling unit for each 1,600 square feet of site area. However, no more than three dwelling units may be placed on a single lot.

Commentary

33.405.070.C. Flag lots

The flag lot provisions allowed for 8 foot versus 10-foot perimeter setbacks. New standards for small flag lots (those less than 3,000 sf) allow for 5-foot perimeter setbacks in the single dwelling zones.

Language to be **added** is underlined
Language to be **deleted** is shown in ~~strikethrough~~

- C. Flag lots averaging 2,500 square feet.** Lots in the R2 ~~and R2.5~~ zone may be developed as flag lots with an average area of 2,500 square feet when the proposed development meets all of the following requirements:
1. Both attached and detached dwellings are allowed;
 2. The average area of the lots created must be at least 2,500 square feet. Each must be at least 1,600 square feet;
 3. The pole portion of the flag lot must be part of the flag lot, must connect to a street, and must be at least 12 feet wide for its entire length;
 4. Detached structures on a flag lot are required to have an eight foot setback from all lot lines. Attached structures on flag lots are required to have an eight foot setback along those lot lines that abut a lot that is not a part of the flag lot development; and
 5. Required setbacks must include a landscaped buffer area. The landscaped area must be at least 3 feet deep and be landscaped to at least the L3 standard.
See Figure 405-1.

**Figure 405-1
Flag Lot Description and Buffer**

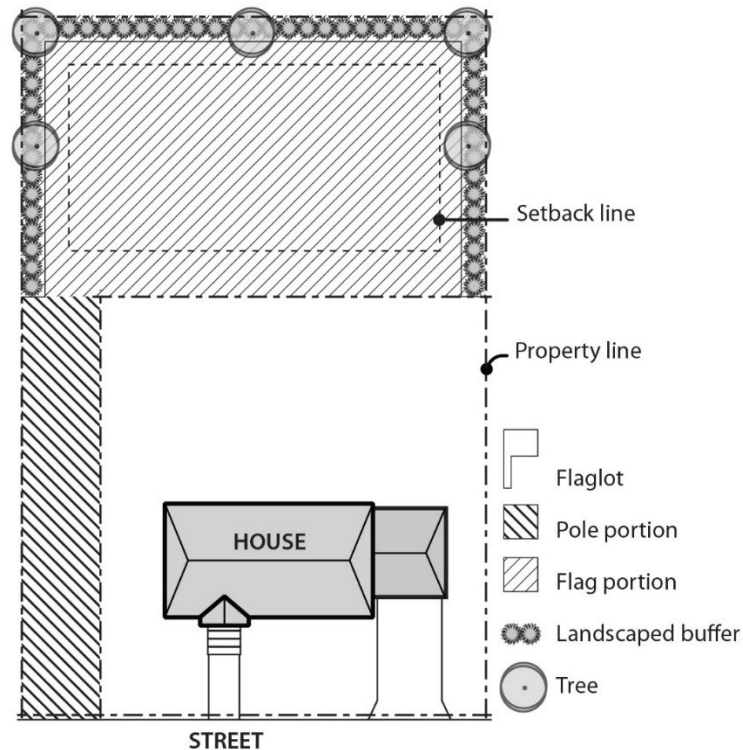

Commentary

D. Design review required.

1. Generally. Proposals taking advantage of the provisions of this section must be approved through design review or meet the Community Design Standards in Chapter 33.218, as set out in Section 33.405.090, Design Review and Community Design Standards, below; and
2. Exception. If the site is a Historic or Conservation Landmark, or in a Historic or Conservation District, it is subject to the regulations for historic resource review as set out in Chapter 33.445, Historic Resource Overlay Zone.
3. Land Division. If the proposal requires, or the applicant requests, a land division, the application for the land division must show how the Community Design Standards are met. If the Community Design Standards cannot be met or the applicant chooses not to meet the Community Design Standards, design review is required. When design review is required, the design review process must be concurrent with the land division. The Community Design Standards must be met or design review must be approved in order for the land division to be approved.
4. Changes to a design approved concurrently with a land division. If the design of the proposed development was reviewed concurrently with the land division through design review, changes to the design of the proposed development after final plat approval must be reviewed through design review. If the proposed development met the Community Design Standards concurrently with the land division, changes to the design of the proposal after final plat approval must continue to meet the Community Design Standards, or must be reviewed through design review. Concurrent land division review is not required to change the design of the proposed development after final plat approval.

Commentary

33.418 Constrained Sites Overlay Zone

This overlay zone is being added to restrict use of the additional housing types allowed in the single-dwelling zones through the Residential Infill Options (see page 107) and the additional accessory dwelling unit allowances for a duplex and a second ADU with a house. The restrictions in this overlay zone will apply to lots that have significant natural resources or a natural hazard that make the lots unsuitable for additional development.

The constraints include lots with any portion located in:

- The City's Natural Resource Inventory areas
- The 100-year flood plain, floodway, and 1996 flood inundation area
- Landslide risk areas (which is comprised of three sets of data layers including rapidly moving landslide potential, high susceptible areas for deep seated landslides, and areas with previous landslide evidence, i.e. scarps and deposits)

33.418 Constrained Sites Overlay Zone

418

Sections:

- 33.418.010 Purpose
- 33.418.020 Map Symbol
- 33.418.030 Applying the Constrained Sites Overlay Zone
- 33.418.040 Housing Type Limitations

33.418.010 Purpose

Under some circumstances, up to four dwelling units is allowed per lot in the R7, R5 and R2.5 zones. The Constrained Sites overlay zone reduces that development potential on lots that have certain development constraints. The constraints make the lots unsuitable for three or four dwelling units.

33.418.020 Map Symbol

The Constrained Sites overlay zone is shown on the Official Zoning Maps with the letter “z” map symbol.

33.418.030 Applying the Constrained Sites Overlay Zone

The Constrained Sites overlay zone is applied to lots in the R7, R5 and R2.5 zones when any portion of the lot has one of the following constraints:

- A. Low, medium, or high value natural resource as shown on the City’s Natural Resources Inventory;
- B. Special flood hazard area;
- C. Floodway;
- D. 1996 Flood Inundation area;
- E. Potential Rapidly Moving Landslide Hazard Zones as shown in the DOGAMI IMS-22 publication;
- F. Deep landslide—High Susceptibility or Landslide Deposit or Scarp as shown in the DOGAMI IMS-57 publication.

33.418.040 Residential Infill and ADU Limitations

The following residential infill and accessory dwelling unit options do not apply in the Constrained Sites overlay zone:

- A. 33.110.265.D for duplexes on interior lots. The regulations for duplexes on corners continues to apply;
- B. 33.110.265.E which allows triplexes and fourplexes in the R7 through R2.5 zones;
- C. 33.205.020.B.2 which allows two accessory dwelling units on a site with a house, attached house, or manufactured home in the R7 through R2.5 zones; and
- D. 33.205.020.B.3 which allows an accessory dwelling unit on a site with a duplex in the R7through R.25 zones.

Commentary

33.420.041.I When Design Review is Required

This subsection is being amended to delete reference to 33.505.230, Attached Residential Infill on Vacant Lots in R5-Zoned Areas, as that section is being deleted.

33.420 Design Overlay Zone

420

33.420.041 When Design Review is Required

Unless exempted by Section 33.420.045, Exempt From Design Review, design review is required for the following:

A.-G. [No change]

H. Proposals using one of the provisions of the a, Alternative Design Density Overlay Zone, specified in Sections 33.405.040 through .080;

I. Proposals in the Albina Community plan district using the provisions of Section 33.505.220, Parking Requirement Reduction, ~~or Section 33.505.230, Attached Residential Infill on Vacant Lots in R5-Zoned Areas;~~

J.-K. [No change]

Commentary

33.505.220 Parking Requirement Reduction

This provision is not applicable to the single dwelling zones as minimum parking is no longer required.

33.505.230 Attached Residential Infill on Vacant Lots in R5 Zoned Areas

This provision, which was adopted in 1997, is being deleted. This provision allows lots in the R5 zone that have been vacant for at least 5 years to be divided using the R2.5 zone standards and requires the attached house development to go through design review or meet the community design standards. The base zone is being amended to allow up to four dwelling units on a lot in the R5 zone and does not require design review for the development.

33.505 Albina Community Plan District

505

Sections:

General

33.505.010 Purpose

33.505.020 Where These Regulations Apply

Use Regulations

33.505.100 Commercial Uses in the RH Zone

Development Standards

33.505.200 Minimum Density Standards

33.505.220 Parking Requirement Reduction

~~33.505.230 Attached Residential Infill on Vacant Lots in R5 Zoned Areas~~

33.505.240 Design Review and Community Design Standards

33.505.245 When Community Design Standards May Be Used

33.505.248 When Community Design Standards May Not Be Used

Map 505-1 Albina Community Plan District

33.505.220 Parking Requirement Reduction

A. [No change]

B. **Where these regulations apply.** The provisions of this section apply in areas zoned ~~R2-5~~, R2 and R1 that are more than 1500 feet from a transit station, or more than 500 feet from a transit street with 20-minute peak hour service.

C. [No change]

~~33.505.230 Attached Residential Infill on Vacant Lots in R5 Zoned Areas~~

~~A. **Purpose.** The increased density permitted by this section encourages infill development in areas that are generally well served by existing public services. The increase allows the area to absorb additional growth without creating market pressure that might lead to the early removal of existing sound housing. The increased density will lower the cost of housing while increasing opportunities for owner-occupied housing. Required design review of new development ensures that the new housing will make a positive contribution to the neighborhood's character.~~

Commentary

- B. ~~Attached residential infill.~~** Attached residential development is allowed if all of the following are met. Adjustments to Subparagraphs B.1 through B.4, below, are prohibited:
- ~~1. The proposed attached residential development will be on a lot or lot of record that was created at least five years ago;~~
 - ~~2. There has not been a dwelling unit on the lot or lot of record for at least five years;~~
 - ~~3. A land division creating an individual lot for each attached housing unit is recorded;~~
 - ~~4. The proposed attached residential development meets all development standards for attached residential development in the R2.5 zone; and~~
 - ~~5. Design review required:~~
 - ~~a. Generally. Attached residential development must be approved through design review or meet the Community Design Standards in Chapter 33.218, as set out in Section 33.505.240, Design Review and Community Design Standards, below; and~~
 - ~~b. Exception. If the site is a Historic or Conservation Landmark, or in a Historic or Conservation District, it is subject to the regulations for historic resource review as set out in Chapter 33.445, Historic Resource Overlay Zone.~~

Commentary

33.563.225 Duplexes and Attached Houses in the Linnton Hillside Subarea

The cross references in this section have been updated. This section previously referred to the alternative development option in the single-dwelling zones that pertained to additional density allowances for corner lot duplexes or attached houses (33.110.240.E).

The references now point to attached houses where an additional unit is allowed for a corner lot (33.110.265.C.1.a.(2)) and the additional density allowances for duplexes (33.110.265.D.1.)

On lots that meet the lot requirements of 33.563.220, attached houses without additional density, will continue to be allowed.

This section does not need to prohibit triplexes, fourplexes and additional ADUs because the new z overlay covers the extent of R2.5, R5 and R7 zoning within the Linnton Hillside area. The z overlay zone prohibits triplexes, fourplexes, and additional ADU's.

33.563 Northwest Hills Plan District

563

33.563.220 When Primary Structures Are Allowed in the Linnton Hillside Subarea

The regulations of Section 33.110.~~202~~212 do not apply in the Linnton Hillside Subarea. In this subarea, primary structures are allowed in single-dwelling residential zones as specified in this section.

Adjustments to the standards of this section are prohibited. Primary structures are prohibited on lot remnants that are not otherwise lots of record or are not combined with lots or lots of record. Primary structures are only allowed if one of the requirements in A. through E. are met:

A. - G. [No change]

33.563.225 Duplexes and Attached Houses in the Linnton Hillside Subarea.

In the Linnton Hillside subarea, duplexes as allowed by 33.110.265.D, and attached houses on corners as allowed by 33.110.265.C.1.a(2) ~~33.110.240.E~~ are prohibited.

Commentary

33.564.360 Planned Development

Triplexes and fourplexes are being added to this list of prohibited uses and development because they were previously categorized as a type of multi-dwelling structure, but multi dwelling structures are now defined as buildings with five or more units.

33.564 Pleasant Valley Plan District

564

33.564.060 When Primary Structures are Allowed

Primary structures are allowed as specified in 33.110.202212 using Table 33.610-2. The lot dimension standards in this chapter do not supersede the lot dimension standards of Table 33.610-2 for the purposes of implementing Section 33.110.202212.

33.564.360 Planned Development

The following uses and development are prohibited through a planned development:

- A. Attached houses;
- B. Attached duplexes;
- C. Triplexes;
- D. Fourplexes;
- ~~E~~C. Multi-dwelling structures; and
- ~~F~~D. Commercial uses.

Commentary

33.610.200.D.2. Minimum lot width.

These criteria allow for reduced lot widths and narrow lots as part of a land division in certain circumstances.

33.610.200.D.2.b.

The minimum lot width for a detached house is being amended to 26 feet for consistency with the narrow lot standards in the base zone.

33.610.200.D.2.c.

This requirement will apply to all houses, duplexes, triplexes, and fourplexes based on the amendments in 33.266.120.C.3. and 33.266.130.C.1

33.610.200.D.2.e.

This landscaping requirement is being added to the base zone chapter to apply to all narrow lots not just to attached houses. This amendment makes this land division criterion consistent with that new base zone landscaping standard.

33.610.200.D.2.f.

The parking standards for houses, attached houses, duplexes and triplexes are being amended to require alley access whenever an alley exists, and parking is proposed. This criterion is being amended to make it consistent with that requirement.

33.610 Lots in RF Through R5 Zones

610

33.610.200 Lot Dimension Regulations

Lots in the RF through R5 zones must meet the lot dimension regulations of this section.

A. - C. [No change]

D. Minimum lot width. Each lot must meet one of the following regulations. Lots that do not meet these regulations may be requested through Planned Development Review. Adjustments to the regulations are prohibited.

1. Each lot must meet the minimum lot width standard stated in Table 610-2; or
2. Minimum lot width may be reduced below the dimensions stated in Table 610-2, if all of the following are met:
 - a. On balance, the proposed lots will have dimensions that are consistent with the purpose of the Lot Dimension Regulations;
 - b. The minimum width for lots that will be developed with detached houses may not be reduced below 2526 feet;
 - c. If the lot abuts a public alley, then vehicle access must be from the alley. ~~This requirement will be imposed as a condition of approval of the land division;~~
 - d. Lots must be configured so that development on the site will be able to meet the garage limitation standard of Subsection 33.110.250.C253.D at the time of development;
 - e. Lots that are less than 32 feet wide ~~will be developed with attached houses~~ must be configured so that 60 percent of the area between the front lot line and the front building line can be landscaped at the time of development; and
 - f. In areas where parking is not required by this Title, lots may be proposed that will not accommodate on-site vehicle access and parking. Such lots do not have to meet the requirements of ~~s~~Subparagraphs 2.c and D.2.d. As a condition of approval of the land division, the property owner must execute a covenant with the city. The covenant must:
 - (1) State that the owner will develop the property without parking, and that a driveway for access to on-site parking may not be created in the future, unless it is in conformance with regulations in effect at the time;
 - (2) Meet the requirements of Section 33.700.060, Covenants with the City; and
 - (3) Be attached to, and recorded with the deed for the new lot.

Commentary

Table 610-1

The table is being revised because land division density calculations result in the number of lots allowed not the number of units allowed.

Language to be **added** is underlined
Language to be **deleted** is shown in ~~strikethrough~~

E. - G. [No change]

Table 610-1 Maximum Density Standard					
	RF	R20	R10	R7	R5
Maximum Density	1 lot <u>unit</u> per 87,120 sq. ft.	1 lot <u>unit</u> per 20,000 sq. ft.	1 lot <u>unit</u> per 10,000 sq. ft.	1 lot <u>unit</u> per 7,000 sq. ft.	1 lot <u>unit</u> per 5,000 sq. ft.

33.610.400 Flag Lots

The following regulations apply to flag lots in the RF through R5 zones:

A. - E. [No change]

- F. **Vehicle access.** Where it is practical, vehicle access must be shared between the flag lot and the lots between the flag portion of the lot and the street. Factors that may be considered include the location of existing garages, driveways, alleys, and curb cuts, stormwater management needs, and tree preservation. Access easements may be used.

Commentary

33.611 Lots in the R2.5 Zone

The changes in this chapter will make it easier to create narrow lots for attached houses. Current regulations require a minimum 36-foot wide lot (the same as required in the R5 zone) even though the minimum lot size is significantly less than in the R5 zone. For example, a 1600 sf lot that is 36 feet wide would be 44 feet deep. Moreover, many R2.5 sites are in areas with typical 50-foot-wide by 100-foot-deep platting, which lend them to narrow (25x100') dimensions.

Under the existing code, lots less than 36 feet wide can be created when certain approval criteria are met. Alternatively, flag lots are allowed when either 1) a house is located that precludes a standard lot division, or 2) the site is less than 50 feet wide. Changing from approval criteria to clear and objective standards for flag lots will make it easier to propose flag lots.

The R2.5 zone was initially established as a row house zone. Changes to the zone over time have made it harder to create lots for attached houses. However, with the proposed changes to the R2.5 base zone to require attached houses on very narrow (25-foot wide) lots, the R2.5 zone will be more like it was originally intended. Where detached structures are proposed, wider lots are required. And where row houses are proposed, lot width minimums are set to facilitate that housing type.

Lots that do not meet these lot width standards may not be adjusted but may be requested through Planned Development review.

The new standards allow for the following lot configurations

1. 36-foot-wide and wider lots:
 - Attached or detached houses allowed, no additional provisions.
2. 26-foot-wide to 36 foot wide lots:
 - A detached house will be allowed where an existing house is situated such that a standard 36 foot wide lot could not fit on the land division site.
 - A detached house will be allowed on an oddly configured parcel, like a narrow through lot, where the sides of the proposed lot do not abut other lots in the land division site and there is insufficient room for a 36 foot wide lot.
3. 21 foot wide and wider lots:
 - Attached houses are allowed where a pair of attached houses is proposed (semi-detached housing) or the lots will be end units in a row of units.
4. 16-foot-wide and wider lots:
 - Attached houses allowed in the middle of a set of rowhouses (this provides consistent house widths in the row, accounting for side yard setbacks for the end units).

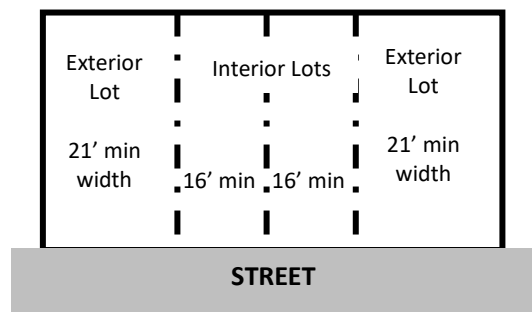

33.611 Lots in the R2.5 Zone

611

33.611.200 Lot Dimension Regulations

Lots in the R2.5 zone must meet the lot dimension regulations of this section. Lots that do not meet these regulations may be requested through Planned Development Review. Adjustments to the regulations are prohibited.

A. - B. [No change]

C. **Minimum lot width.** Each lot must meet one of the following regulations. ~~Lots that do not meet these regulations may be requested through Planned Development Review. Adjustments to the regulations are prohibited.~~

1. Each lot must be at least 36 feet wide; or
2. Minimum lot width may be reduced to 26 feet if the following are met:
 - a. An existing dwelling unit or attached garage is located on the site so that it precludes a land division that meets the minimum lot width standard of Paragraph C.1. The dwelling unit and attached garage must have been on the site for at least 5 years; or
 - b. The side lot line of a lot that is less than 36 feet wide will not abut the side lot line of any other lot within the land division site.
3. Minimum lot width may be reduced to 21 feet for a lot if the lot will be developed with an attached house that shares a common wall with at least one other attached house.
4. Minimum lot width may be reduced to 16 feet for a lot if the lot will be developed with an attached house that shares two common walls with two other attached houses.
2. ~~Minimum lot width may be reduced below 36 feet, if all of the following are met:~~
 - a. ~~On balance, the proposed lots will have dimensions that are consistent with the purpose of this section;~~
 - b. ~~The minimum width for lots that will be developed with detached houses may not be reduced below 25 feet;~~
 - c. ~~If the lot abuts a public alley, then vehicle access must be from the alley. This requirement will be imposed as a condition of approval of the land division;~~
 - d. ~~Lots must be configured so that development on the site will be able to meet the garage limitation standard of Subsection 33.110.253.D, at the time of development;~~
 - e. ~~Lots that will be developed with attached houses must be configured so that 60 percent of the area between the front lot line and the front building line can be landscaped at the time of development; and~~

Commentary

33.611.200.C.2. Minimum lot width (previous page)

This paragraph is replaced by new lot width standards. Requirements that were included for alley access, lot configuration, and covenants are no longer necessary since all narrow lots (less than 32 feet wide) are now subject to the requirements in 33.110.260, Additional Development Standards for Narrow Lots

33.611.200. D. Minimum Front Lot Line.

These changes are made to allow the front lot line (typically 30 feet) to be reduced to match the reduced lot widths described above.

~~f. In areas where parking is not required by this Title, lots may be proposed that will not accommodate onsite vehicle access and parking. Such lots do not have to meet the requirements of subparagraphs 2.c and d. As a condition of approval of the land division, the property owner must execute a covenant with the city. The covenant must:~~

- ~~(1) State that the owner will develop the property without parking, and that a driveway for access to on-site parking may not be created in the future, unless it is in conformance with regulations in effect at the time;~~
- ~~(2) Meet the requirements of Section 33.700.060, Covenants with the City; and~~
- ~~(3) Be attached to, and recorded with the deed for the new lot.~~

D. Minimum front lot line. Each lot must have a front lot line that is at least 30 feet long. Lots that are created under the provisions of Paragraph ~~C.2. through C.4. above~~, may reduce the front lot line to equal the width of the lot.

E. - F. [No change]

33.611.400 Flag Lots

The following regulations apply to flag lots in the R2.5 zones:

A. [No change]

B. When a flag lot is allowed. A flag lot is allowed only when the following are met:

1. One of the following ~~is~~ are met:
 - a. An existing dwelling unit or attached garage on the site is located so that it precludes a land division that meets the minimum lot width standard of Paragraph 33.611.200.C.1. The dwelling unit and attached garage must have been on the site for at least five years; or
 - b. The site has a width of less than 50 feet if two lots are proposed and a width of less than 75 feet if three lots are proposed.
2. Up to three lots are proposed, only one of which is a flag lot; and
3. Minimum density requirements for the site will be met.

C. - E. [No change]

F. Vehicle access. Where it is practical, vehicle access must be shared between the flag lot and the lots between the flag portion of the lot and the street. Factors that may be considered include the location of existing garages, driveways, alleys, and curb cuts, stormwater management needs, and tree preservation. Access easements may be used.

Commentary

33.676 Lot Confirmation

This is a new chapter and set of rules to formalize the Lot Confirmation process. Confirming lots as individual buildable pieces of property has been an evolving practice. What was once an informal verification of the legality of the lot's creation has become more formalized to include reviews by service bureaus for changes to utility access, deed research to confirm the validity and ownership status of the lot over time, and an examination of some development standards to ensure the separation of a site does not create non-conforming development.

The County tax assessor now requires a letter from the City confirming that the lot is legal and developable prior to creating a new tax account for the property. This helps prevent potential buyers from purchasing a piece of property that is not buildable. This process also ensures that any utility encroachments are removed or resolved before the lot is considered independently buildable.

This chapter is modeled largely after 33.677 Property Line Adjustments

33.676.100 Prohibited Lot Confirmations

Properties that were not lawfully created through a deed recorded prior to July 26, 1979 or a properly recorded land division plat cannot be confirmed through a lot confirmation. Instead a land division would be required to validate such properties, subject to some additional State statutes.

33.676.200.B.

In some instances, the Zoning Code stipulates that a lot had to be under separate ownership from abutting lots or that the ownerships had not been combined at any time since their creation. In these cases, supporting documentation illustrating chain of ownership of the property and abutting properties is necessary.

33.676 Lot Confirmation

676

Sections:

- 33.676.010 Purpose
- 33.676.100 Prohibited Lot Confirmations
- 33.676.150 Method of Review
- 33.676.200 Application Requirements
- 33.676.300 Standards
- 33.676.400 Finalizing the Lot Confirmation

33.676.010 Purpose

This chapter states the procedures and regulations for confirming a lot, lot of record or combination of lots or lots of record. A Lot Confirmation recognizes the developability of a lot, lot of record, or combination of lots or lots of record. The regulations ensure that the Lot Confirmation does not:

- Create a new lot;
- Result in development sites that no longer meet the dimensional requirements and development standards of this Title;
- Alter the availability of existing services to a site; and
- Result in sites that no longer meet conditions of approval of a previous land use review.

33.676.100 Prohibited Lot Confirmations

A Lot Confirmation cannot be used to create a buildable lot from an unbuildable plot or to create plots.

33.676.150 Method of Review

Lot Confirmations are reviewed through a non-discretionary, administrative procedure. The decision of the Director of BDS is final.

33.676.200 Application Requirements

The application for a Lot Confirmation must contain the following:

- A. Application Form.** One copy of the completed application form bearing an accurate legal description, tax account number and location of the property. The completed form must also include the name, address, telephone number, and original signatures of the applicant and all property owners and the nature of the applicant's interest in the property.
- B. Supporting documentation.** Documentation that establishes when and how the lot was created is required. For Lot Confirmations where the base zone requires that the lot was under separate ownership from abutting lots, ownership information for the lot and abutting lots is also required. This may include copies of recorded plats, historic deeds, or other documentation that provides evidence of the creation and chain of ownership of the property.

Commentary

33.676.300.B. Minimum lot dimension standards.

Adjustments are prohibited to these lot size and frontage standards. Moreover, a property line adjustment may not be used to alter the dimensions of a substandard lot to make it meet these standards. The intention is that for lots that existed prior to a land division that already meet certain reduced standards, these will be recognized as developable, even though they may not meet density requirements for the zone. If the substandard lot needs to be modified, then it should be subject to current land division requirements, including density standards.

The standards for single-dwelling zones also include that the lots must have street frontage. This is in part because measuring lot width in single-dwelling zones is measured at the front setback line. There is no front setback when there is no street frontage, making it impossible to determine if the lot meets the 36-foot minimum width requirement. Also, lots without street frontage lack access for residents and utilities unless easements are provided. Easements are generally not acceptable for some utility connections and cannot be established until *after* the lots are in separate ownership.

A reference to overlay zone and plan district requirements is included to capture the additional requirements of Linnton (NW Hills), Glendoveer, Pleasant Valley, etc.

33.676.300.C. Development Standards.

This standard ensures that when confirming a lot for development, the development on the original site does not become non-conforming, or does not increase the degree of non-conformity. This may include loss of required parking spaces, reductions to setbacks, exceeding building coverage or FAR limits, etc. In these cases, adjustments to the development standards may be requested, to the degree that adjustments are allowed for those standards. Note that FAR is not an adjustable standard.

C. Site plan and supplemental survey.

1. A site plan no larger than 18 inches by 24 inches in size is required for all applications. The site plan must be drawn to scale and show:
 - The location of existing lot or property lines;
 - The boundaries of the re-established lot, lot of record, or combinations thereof;
 - All development on the site including driveways and parking areas;
 - The location of utilities and services; and
 - The location and dimensions of existing curb cuts abutting the site.
2. If existing buildings on the site will remain after the lot confirmation, a supplemental survey signed and stamped by a registered land surveyor is also required. The survey must show the distances between the buildings on the lot and the property line that is being confirmed.

33.676.300 Standards

A request for a Lot Confirmation will be approved if all of the following are met:

- A. Lot or lot of record.** Each lot or lot of record that will be confirmed meets the definition of lot or lot of record.
- B. Minimum lot dimension standards.** The following lot dimension standards apply to each lot, lot of record or combination of lots or lots of record. The standards must be met without necessitating a property line adjustment. Adjustments are prohibited:
 1. In the OS, C, EX, CI and IR zones, each lot must have a front lot line that is at least 10 feet long. There are no other minimum lot dimension standards.
 2. In the single-dwelling zones, each lot must have frontage on a street, and each lot must meet the standards of 33.110.202, Development on Lots and Lots of Record.
 3. In the multi-dwelling zones, each lot must have frontage on a street, and each lot must meet the standards of Section 33.120.210, Development on Lots and Lots of Record.
 4. In the EG zones, each lot must meet Standard B stated in Table 614-1.
 5. In the I zones, each lot must meet Standard B stated in Table 615-1.
 6. If the lot is in an overlay zone or plan district that regulates minimum lot dimensions, the minimum lot dimension standards of the overlay zone or plan district must be met instead of the standard that corresponds to the base zone.
- C. Development standards.** If existing development is in conformance with the development standards of this Title, the development must remain in conformance after the Lot Confirmation. If existing development is not in conformance with a development standard of this title, the Lot Confirmation will not cause the development to move further out of conformance with the standard unless an adjustment is approved.

Commentary

33.676.300.D. Services. This standard includes the requirement to examine service bureau requirements to ensure the lot does or can be made to comply with service bureau requirements.

33.676.300.E. Conditions of previous land use reviews. To change the applicability of a condition of approval that is still relevant to a site, a new land use review would be required, adjustments are not allowed.

33.676.400

Following the Lot Confirmation approval, the applicant must submit the decision to the County to obtain a new tax account. A timeline has been established for this submittal to prevent approvals from getting "stale". That is where the approval sits without being acted upon, the development or Lot Confirmation rules change and the lot would not be confirmable under the new requirements. The timeline does not pertain to when the county assigns the tax account number, only when the request is submitted to the county for processing.

Language to be **added** is underlined
Language to be **deleted** is shown in ~~strikethrough~~

- D. Services.** The Lot Confirmation will not eliminate the availability of services to any lot affected by the Lot Confirmation, and the lots will not move out of conformance with service bureau requirements for water, sanitary sewage disposal, and stormwater management, unless approved by the affected service bureau.
- E. Conditions of previous land use reviews.** All applicable conditions of previous land use reviews must be met, see 33.700.110, Prior Conditions of Land Use Approvals. Adjustments are prohibited.

33.676.400 Finalizing the Lot Confirmation

A Lot Confirmation approval must be submitted to the appropriate county assessment and taxation office within 90 days of the City's decision. The County is responsible for creating separate tax identification numbers for each confirmed lot.

Commentary

33.677 Property Line Adjustment

The Chapter is being renumbered to accommodate the new Lot Confirmation chapter.

33.677.100 Prohibited Property Line Adjustments

A. Flag lots. Additional flexibility has been added to allow flag lots through a property line adjustment in the R5 and R2.5 zone provided certain qualifications are met, including the added standards in 33.677.300.C.

B. Unbuildable Lots. The current code allows lots to be confirmed even though they do not meet minimum width or area requirements, provided a concurrent property line adjustment is proposed that would satisfy the dimensional requirements. For example, in the R7 zone with 3 lots that are substandard in width (less than 40 feet wide) a concurrent property line adjustment could previously be used to move one lot line, forming two lots that are wide enough to be buildable.

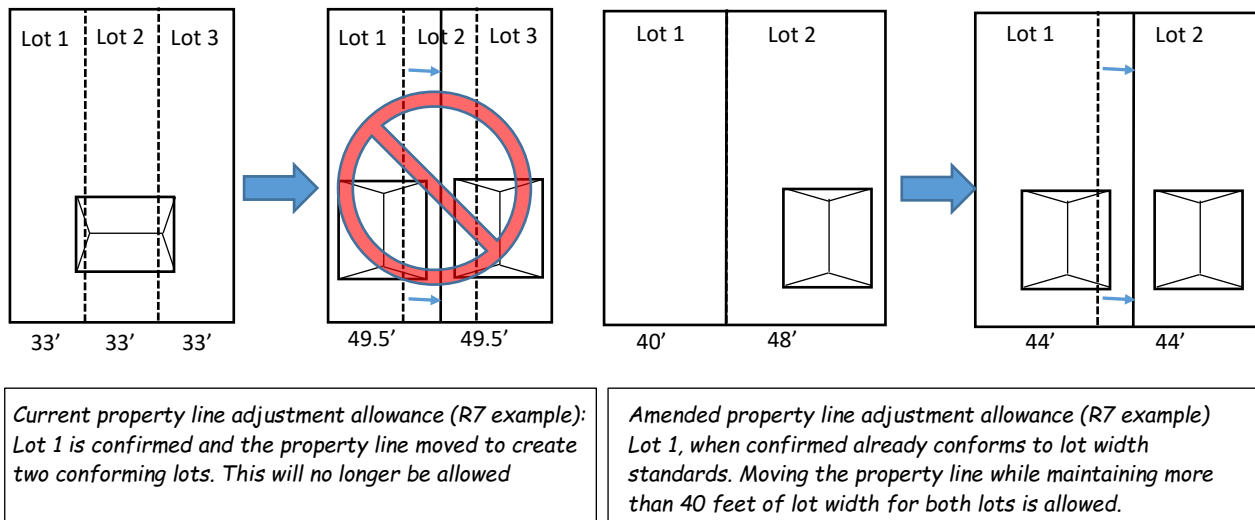

The amendment in essence establishes a two-step process. First, one must be able to develop on the lot or lot of record (it's a legal lot, large enough and wide enough). Only then can one modify the lot lines. This prohibits Property Line Adjustments from being used to create buildable lots from lots (or lot remnants, etc) that are unbuildable since they did not meet the requirements for when primary structures are allowed (e.g. 33.110.202). Where lot density requirements can be met, a land division in these cases could be proposed.

D. Alley Frontage. Emphasis is being added for lots that have alley frontage in terms of locating vehicle access. For example, lots that abut an alley will be required to use the alley to access any parking that may be proposed. To prevent circumventing this requirement, property line adjustments will not be allowed to configure the lot to remove the alley frontage.

33.67733.667 Property Line Adjustment

677667

Sections:

- 33.~~677667~~.010 Purpose
- 33.~~677667~~.050 When these Regulations Apply
- 33.~~677667~~.100 Prohibited Property Line Adjustments
- 33.~~677667~~.150 Method of Review
- 33.~~677667~~.200 Application Requirements
- 33.~~677667~~.300 Standards
- 33.~~677667~~.400 Recording an Approval

33.677667.100 Prohibited Property Line Adjustments

The following are prohibited as part of a Property Line Adjustment:

- A.** A Property Line Adjustment that configures either property as a flag lot, unless:
 - 1. The the property was already a flag lot; or
 - 2. Both properties are in the R5 or R2.5 zone and:
 - a. There is an existing house on one or both properties;
 - b. Only one flag lot is proposed;
- B.** A Property Line Adjustment that results in the creation of a buildable property from an unbuildable lot, lot of record, or lot remnant;
- C.** A Property Line Adjustment that results in the creation of street frontage for property that currently does not have frontage on a street; ~~and~~
- D.** A Property Line Adjustment that removes alley frontage from one or both properties; and
- E. ~~D.~~** A Property Line Adjustment that creates a nonconforming use.

33.677667.150 Method of Review

Property Line Adjustments are reviewed through a non-discretionary, administrative procedure. The decision of the Director of BDS is final.

33.677667.200 Application Requirements

No more than three Property Line Adjustments may be requested on a site within one calendar year. The application must contain the following:

- A. Application form.** Two copies of the completed application form bearing an accurate legal description, tax account numbers and location of the property. The application must include the name, address, telephone number, and original signatures of the applicant and all property owners and the nature of the applicant's interest in the property.

Commentary

33.677.300.A.2

A new provision is added to afford more flexibility when proposing a flag lot PLA. The ability to use a property line adjustment to create a flag lot is intended as an incentive to retain existing houses on Historically Narrow Lots. Frequently, existing houses will exceed the typical max FAR (1,250 - 1,500 square feet). By allowing the house to exceed the maximum FAR enables the PLA to be approved. Subsequent development (either on the vacant flag lot or as an alteration to the house) will have to comply with the maximum FAR.

33.677.300.A.5

This provision is also known as “the corner lot swivel”. It allows historically narrow corner lots in the R5 zone to rotate the lot line to create two standard width lots for detached houses. The reference to the additional standards in 33.110.213 is being removed. These standards have been amended and apply specifically to narrow lots. Since the adjusted lots will no longer be narrow, these additional standards will not apply

B. Surveys.

1. Three paper copies of a property line survey. The survey must be prepared, stamped and signed by a registered land surveyor to meet ORS 92.050. The survey must show all existing and proposed property lines and all existing lot lines. The survey may not be larger than 18 inches by 24 inches in size. The survey must be drawn to a scale no less than 1 inch = 200 feet, and no greater than 1 inch = 20 feet;
2. One copy of the property line survey that is 8-1/2 by 11 inches in size; and
3. One paper copy of a survey of the proposed PLA prepared, stamped, signed, and attested to for accuracy by a registered land surveyor, showing the location, dimensions and setbacks of all improvements on the site. This survey map must be drawn to a scale at least 1 inch = 200 feet.

- C. Legal description.** Two copies of the legal description for each adjusted property and each exchange parcel. The legal descriptions must be prepared and signed by a registered land surveyor.

33.677667.300 Standards

The site of a Property Line Adjustment is the two properties affected by the relocation of the common property line. A request for a Property Line Adjustment will be approved if all of the following are met:

- A. Conformance with regulations.** Both pProperties will remain in conformance with regulations of this Title, including those in Chapters 33.605 through 33.615, except as follows:

1. If a property or development is already out of conformance with a regulation in this Title, the Property Line Adjustment will not cause the property or development to move further out of conformance with the regulation;
2. If the Property Line Adjustment will configure one of the properties as a flag lot, nonconformance with the maximum floor area ratio standard is allowed for the existing development at the time of the property line adjustment. Future alterations may not move the development further out of conformance and new development must comply with the maximum floor area ratio;
- ~~3.~~ If both properties are already out of conformance with maximum lot area standards, they are exempt from the maximum lot area standard;
- ~~4.~~ If one property is already out of conformance with maximum lot area standards, it is exempt from the maximum lot area standard; and
- ~~5.~~ If at least one lot is already out of conformance with the minimum lot area standards and the site is in the R5 zone, the minimum lot area is 1600 square feet and the minimum width is 36 feet, if:
 - a. At least one lot is a corner lot; and
 - b. The adjusted property line must be perpendicular to the street lot line for its entire length; ~~and~~
 - ~~c. New houses must meet the standards of 33.110.213. Existing houses are exempt from the standards of 33.110.213.~~

See Figure ~~66~~77-1.

Commentary

Language to be **added** is underlined
Language to be **deleted** is shown in ~~strikethrough~~

- B. Regular ~~Lot~~ Lines.** In the R10 through RH and RMP zones, the adjusted property line must be a straight line or up to 20 percent shorter or 20 percent longer than the existing lot line. Lines that are adjusted to follow an established zoning line or the boundary of the special flood hazard area or floodway are exempt from this requirement.

Figure 6677-1
Property Line Adjustment on Corner Site in R5 Zone

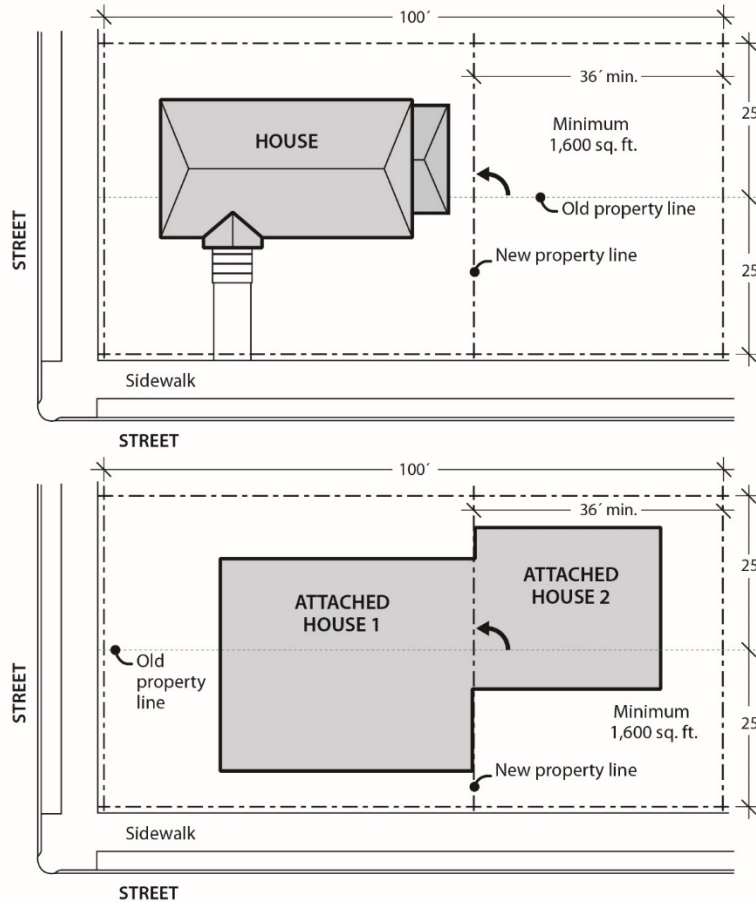

Commentary

33.677.300.C Flag Lots in the R5 and R2.5 Zone.

Many Historically Narrow Lots are sites comprised of pairs of 25' x 100' lots. Those sites may be developed with a house+one or two ADUs, pair of attached houses, duplex+ADU, triplex or fourplex.

One alternative to redevelopment that would permit a homeowner to remain in place while taking advantage of the underlying lot and providing for a modest home available for separate purchase (i.e. "fee-simple ownership") is to allow a property line adjustment to reconfigure the parallel lots into a flag lot.

Presently, property line adjustments that configure lots into flag lots are prohibited. In general, flag lots are a less desirable urban form, as they put houses in the back yards of other houses, disrupting the pattern of yards in a block and adding driveways and impervious area. However, in some cases, lot configuration or existing development prevent standard side by side lots, making flag lots the only alternative for land divisions, and thus an option for infill in limited cases.

This change would permit a property line adjustment to reconfigure already existing lots when there is an existing house on the site, the reconfigured lots must be at least 1,600 s.f. and the flag lot may not exceed 3,000 s.f. This ensures that minimum lot area requirements apply, and the maximum lot area ensures that the standards for small flag lots apply (33.110.255).

Additional flexibility is also added to the base zone to reduce the setback from the existing house to the pole (33.110.220.D).

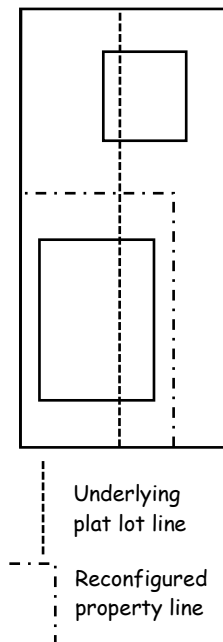

C. Flag Lots in the R5 and R2.5 Zone. In the R5 and R2.5 zone, a Property Line Adjustment may be used to configure a property as a flag lot when all the following are met:

1. Flag pole. The pole portion of the flag lot must meet the following standards. Adjustments are prohibited:
 - a. The pole must connect to a street;
 - b. Pole width:
 - (1) If the pole portion of the flag lot will provide vehicle access to the flag portion of the flag lot, the pole must be at least 12 feet wide for its entire length; or
 - (2) If the pole portion of the flag lot will not provide vehicle access to the flag portion of the flag lot, the pole must be at least 10 feet wide for its entire length. A covenant must be recorded with the deed specifying that no vehicle access is allowed along the pole.
2. Lot dimensions. The lots must meet the following lot dimension standards:
 - a. Lot area.
 - (1) Minimum lot area. Each reconfigured lot must be at least 1,600 square feet. Only the area of the flag portion is included when calculating the minimum lot area for the flag lot. The area of the pole portion of the lot is not included.
 - (2) Maximum flag lot area. The area of the flag lot must be less than 3,000 square feet. The total area of the flag lot, including the pole portion, is included when calculating the maximum lot area for the flag lot.
 - b. Front lot line. There is no minimum front lot line standard for the flag lot.
 - c. Lot width and depth. The minimum lot width and minimum lot depth required for the flag lot is 36 feet measured at the midpoints of the opposite lot lines of the flag portion of the lot. The minimum lot width for the lot in front of the flag lot is 36 feet.

~~DC.~~ Split zoning. The Property Line Adjustment will not result in a property that is in more than one base zone, unless that property was already in more than one base zone.

~~ED.~~ Environmental overlay zones. If any portion of either property is within an environmental overlay zone, the provisions of Chapter 33.430 must be met. Adjustments are prohibited.

~~FE.~~ Services. The adjustment of the property line will not eliminate the availability of services to the properties and the properties will not move out of conformance with service bureau requirements for water, sanitary sewage disposal, and stormwater management. Adjustments are prohibited.

~~GF.~~ Conditions of previous land use reviews. All conditions of previous land use reviews must be met. Adjustments are prohibited.

33.677667.400 Recording an Approval

The Property Line Adjustment application, survey, legal descriptions, and the deed for the exchange parcel must be recorded with the County Recorder and Surveyor within 90 days of the final decision.

Commentary

Table 825-1

In the RF- R2.5 zones, for development on small or narrow lots that were created prior to July 26, 1979, there were additional development standards that applied. These standards were revised and are now embedded in 33.110.260 Additional Development Standards for Narrow Lots (see page 101). Included in those changes is the ability to request deviations from the standards through an adjustment review as opposed to requesting a design review modification. Therefore, this reference in the Table is no longer necessary.

33.825 Design Review

825

Table 825-1 Procedure Type for Design Review Proposals			
Base Zones			
All zones	Signs	In design overlay zones	Type II
	Exterior mechanical equipment		
	New or replacement awnings		
C zones	Planned Development	Using the Planned Development bonus provision described in 33.130.212	Type III
C, E, I, RX, CI zones	Facade alteration	≤ 500 square feet in design overlay zones	Type II
RF—R2.5 zones	Subject to section 33.110.213, Additional Development Standards	Requests to modify standards	Type II
IR zone site with an approved Impact Mitigation Plan (IMP)	Proposals that are identified in IMP	IMP design guidelines are qualitative	Type II
	Proposals that are identified in IMP	IMP design guidelines are objective or quantitative	Type Ix

[No changes to remainder of Table 825-1]

Commentary

33.854 Planned Development Review

The changes shown here incorporate additional review criteria related to cluster housing open space and circulation.

33.854.200.C. Review Procedures

For Planned Developments, the changes reduce the review type from a Type III review to a Type IIX review for multi dwelling development proposals. (sites containing more than one primary dwelling unit on a single lot). Planned Developments that propose multi dwelling structures (buildings containing five or more units) are still subject to a Type III review.

For sites in R7 through R2.5, the threshold for Type III review has been increased from 11 to 21 units. While this is not directly equivalent to a 10 lot land division that could allow up to 4 units per lot, there are many variables that make direct parity impossible and/or create significant complexity in the code. To be directly parallel, an applicant would need to demonstrate that the site could be divided into at least 10 lots that meet minimum lot sizes for 3-4 units, considering right of way needs, site constraints and lot configurations. A requirement to develop a land division plan for the purposes of determining an equivalent review threshold is impractical and counter to the purpose of more holistic site planning for planned developments. Therefore, for the sake of simplicity while still acknowledging higher unit potential in the higher density single dwelling zones and other zones where household living is allowed, the threshold has been doubled to 20 units.

33.854 Planned Development Review

854

Review of Planned Development

33.854.200 Review Procedures

- A. Concurrent reviews.** When land use reviews in addition to Planned Development Review are requested or required, all of the reviews must be processed concurrently, except for Design Review for buildings within a Planned Development site when the Planned Development bonus is being utilized (See 33.130.212.E). In this case, Design Review may be processed after the Planned Development Review.
- B. Planned Development bonus.** Proposals that are using the commercial/mixed use zones Planned Development bonus (See 33.130.212.E) are processed through a Type III procedure, but with the additional steps required under Section 33.700.025, Neighborhood Contact.
- C. All other Planned Development Reviews.**
1. Review in conjunction with a land division. When a Planned Development is requested in conjunction with a land division, the review will be processed as follows:
 - a. Type III review. Proposals in the RF through R2.5 zones that include ~~attached duplexes, multi-dwelling structures, or multi-dwelling development~~ are processed through a Type III procedure, but with the additional steps required under Section 33.700.025, Neighborhood Contact.
 - b. Type IIx review. All other proposals are processed through the Type IIx procedure, but with the additional steps required under Section 33.700.025, Neighborhood Contact.
 2. Review not in conjunction with a land division. When a Planned Development is not in conjunction with a land division, the review will be processed as follows:
 - a. Type III review. ~~Planned Developments Proposals~~ that include any of the following elements are processed through a Type III procedure, but with the additional steps required under Section 33.700.025, Neighborhood Contact:
 - (1) ~~Attached duplexes, Multi-dwelling structures, or multi-dwelling development~~ in the RF through R2.5 zones;
 - (2) Eleven or more units in the RF through R10 zones
 - (3) Twenty-one or more units in R7 through R2.5, Multi-Dwelling, Commercial/Mixed Use, CI2, IR and EX zones;
 - ~~(4)(3)~~ Four or more units where any building location, utility, or service is proposed within a Potential Landslide Hazard Area;
 - ~~(5)(4)~~ Environmental review;
 - ~~(6)(5)~~ Any portion of the site is in an Open Space zone.
 - b. Type IIx review. All other proposals not assigned to a Type III in Subparagraph C.2.a. are processed through a Type IIx procedure, but with the additional steps required under Section 33.700.025, Neighborhood Contact.

Commentary

33.854.310 Approval Criteria for Planned Developments in All Zones

Corrected the reference for the applicable criteria for proposals seeking additional height or FAR in the CM2, CM3, CE and CX zones.

Changed the reference to refer to two new criteria (G. Pedestrian Access and H. Garbage and Recycling Areas)

33.854.310.A. Urban design and development framework.

Two minor changes: the first updates the name from "master plan area" to "planned development area" for clarity and to be more accurate. The second removes the extemporaneous "and" at the end of the list.

33.854.310.E. Site Design.

These changes highlight the need to orient development to the adjacent streets, to prevent the design from "turning its back" to the street. Public realm is also clarified to include plazas and other gathering areas that are accessible from the street. Also, the extemporaneous "and" was removed from the end of this list.

33.854.310 Approval Criteria for Planned Developments in All Zones

Criteria A through ~~EF~~ apply to proposals for additional height or FAR in the CM2, CM3, CE, and CX zones that are taking advantage of 33.270.100.I. If the Planned Development is not proposing additional height or FAR as allowed by 33.270.100.I, then only criteria E through Hand F apply.

A. Urban design and development framework.

1. The proposed overall scheme and site plan provide a framework for development that meets applicable Community Design Guidelines and will result in development that complements the surrounding area;
2. Scale and massing of the development addresses the context of the area, including historic resources, and provides appropriate scale and massing transitions to the adjacent uses and development specifically at the edges of the Planned Development~~Master Plan~~ area;
3. Proposed plazas, parks, or open areas are well located to serve the site and public, and are designed to address safety and comfort of users; and
4. The site plan promotes active ground floor uses on key streets to serve the development and surrounding neighborhood.~~;~~~~and~~

B. Transportation system. [No change]

C. Stormwater Management. [No change]

D. Phasing Plan. [No change]

E. Site Design. Configure the site and development to visually integrate both the natural and built features of the site and the natural and built features of the surrounding area. Aspects to be considered include:

1. Orienting the site and development to the public realm, while limiting less active uses of the site such as parking and storage areas along the public realm. Public realm includes adjacent streets as well as plazas and common open areas that are accessible from the street;
2. Preservation of natural features on the site, such as stands of trees, water features or topographical elements;
3. Inclusion of architectural features that complement positive characteristics of surrounding development, such as similar building scale and style, building materials, setbacks, and landscaping;
4. Mitigation of differences in appearance through means such as setbacks, screening, landscaping, and other design features;
5. Minimizing potential negative effects on surrounding residential uses; and
6. Preservation of any City-designated scenic resources.~~;~~~~and~~

Commentary

33.854.310.F Open Area

These changes add a title to the subsection, and differentiate criteria for providing “adequate open area” for proposals that include attached houses, duplexes, triplexes, fourplexes or multi dwelling structures from proposals that include only detached primary units (houses).

For multi-dwelling developments with detached single units, a “featured open area” is required. The intent is to have this area be a focal point for the development by orienting at least half the units around it.

33.854.310.G. Accessible connections

When multi dwelling development or multi dwelling structures are proposed in zones where they are not allowed outright, pedestrian connections are not specifically addressed in the base zone. This new criterion ensures pedestrian connections are provided between buildings and the street or parking area and call for a pleasant pedestrian experience to encourage walking through the site.

33.854.310.H Garbage and Recycling Areas

When multi dwelling development or multi dwelling structures are proposed in zones where they are not allowed outright, garbage and recycling areas are not specifically addressed. This new criterion ensures that adequate area and attention is given to the functional needs for garbage and recycling collection.

- F. Open Area.** ~~Provide adequate open area on~~ On sites zoned RF through R2.5:
1. ~~Where proposed development includes attached houses, duplexes, triplexes, fourplexes, attached duplexes, or multi-dwelling structures, or multi-dwelling development, adequate open area to accommodate the proposed development must be provided.~~ Open area does not include vehicle areas.
 2. Where multi-dwelling development with detached single dwelling units is proposed, 50 percent of the total number of dwelling units on the site must be oriented around a common outdoor area.
- G. Accessible connections.** Provide one or more accessible routes that connect all buildings on the site to adjacent streets, common open areas, and parking areas. Use landscaping and site furnishings to ensure the accessible route provides a pleasant user experience.
- H. Garbage and recycling areas.** Garbage and recycling collection areas must be adequate in size to accommodate the proposed development, designed to encourage recycling, and located to facilitate pick-up service. Screening and buffering of garbage and recycling areas must be provided to maintain a clean and attractive development.

Commentary

33.900 List of Terms

Basement is a new term being added which correlates to the definition of "Floor Area"

Connected Structure is a new term being added which is used to better distinguish attached and detached accessory structures.

Fourplex is being added as a type of residential structure that is distinct from multi-dwelling structures.

No other changes to the list of terms are being made.

33.900 List of Terms

900

33.900.010 List of Terms

The following terms are defined in Chapter 33.910, Definitions, unless indicated otherwise.

Basement

Connected Structure

Fourplex See Residential
Structure Types

Residential Structure Types

- Fourplex

Commentary

33.910 Definitions

Attached structure. The definition of attached structure is being revised to more closely align with the definition of attached houses. In both cases, the term "attached" will mean that the structures share a wall or floor/ceiling (the floor of one structure is the ceiling of the other). The revision to the definition of attached structure helps to clarify the difference between a structure that is attached and one that is connected to another. Structures that are connected are not joined by walls or floor/ceilings. Connected structures are connected by a minor element such as a breezeway, and connected structures appear more like detached structures.

Basement. A definition of basement is being added to the zoning code because basements are exempt from the measurement of floor area. Floor area, which is intended to be a measure of building bulk, includes exemptions for building space that is partially or fully below grade. The definition of basement is intended to ensure that daylight basements and other basement levels that are at least half concealed below the ground are not counted toward the maximum FAR limit. This in part addresses concerns that some existing basement floors that are less than 4 feet below grade, but are still half below ground (e.g. 3 ½ feet down, 3 ½ feet up). This would also consider a daylight basement a "basement" provided for example -one wall was up to 100% exposed, the opposite wall was 0% exposed and the side walls each 50% or less exposed.

Building Coverage. The definition of building coverage currently excludes eaves from the calculation. The exclusion is intended to encourage the use of eaves on houses and other buildings. However, very deep eaves have been proposed to provide cover over decks and balconies. When this occurs, the eave is acting as a roof and should be counted toward building coverage. Therefore, the definition of building coverage is being amended so that only eaves up to 2 feet deep are excluded from building coverage. A corollary amendment in the Single-Dwelling Zones chapter will allow eaves to project up to 2 feet into setbacks.



Connected structure. This is a new definition used to distinguish "attached structure" from a structure that is attached to a primary structure by a cover or deck. These connected structures are being regulated more similarly to detached structures.

33.910 Definitions

910

Attached Structure. Any structure that is attached to a primary~~another~~ structure by a common wall or shares a common floor/ceiling. For example, a garage is an attached structure when it shares a common wall with a primary dwelling unit. Structures that are attached solely by elements other than a common wall or floor/ceiling are not considered attached. See Connected Structure, ~~by a roof, or by structural connections that allow pedestrian access to both structures.~~ For example, ~~decks or stairways are attached structures when they are connected to another structure.~~ A garage may be attached to another structure by sharing a wall or by a roofed structure such as a breezeway. Structures connected by an "I" beam or similar connections are not considered attached.

Basement. The portion of a building that is partly or completely below grade. A minimum of 50 percent of the total combined area of the basement walls must be below grade to be considered a basement. Only one basement level may be partly below grade; additional basement levels must be completely below grade.

Building Coverage. The area that is covered by buildings or other roofed structures. A roofed structure includes any structure more than 6 feet above grade at any point, and that provides an impervious cover over what is below. Building coverage also includes uncovered horizontal structures such as decks, stairways and entry bridges that are more than 6 feet above grade. Eaves up to 2 feet in depth are not included in building coverage. See Figure 910-11.

Figure 910-11
Area of eave excluded from building coverage

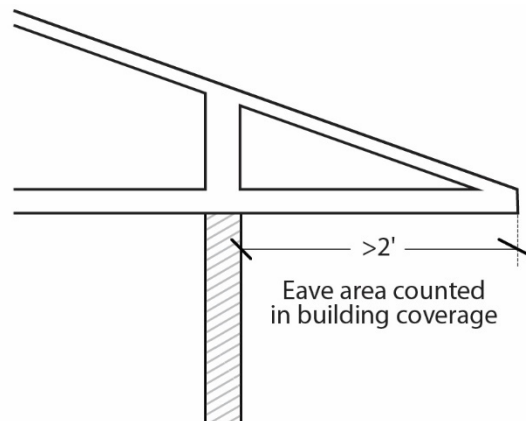

Connected Structure. Any structure that is connected to a primary structure by a roof, a deck or by other structural connections, and which does not share a common wall, ceiling or floor. For example, decks or stairways are connected structures when they are fastened to a primary structure. A garage that is connected to a primary structure by a roofed structure such as a breezeway, and does not share a common wall with the primary structure, is a connected accessory structure. See Attached Structure.

Commentary

Floor area. Because FAR limits will apply in single-dwelling zones, minor revisions to the definition of floor area are being made to address smaller residential structure types. (See definition of basement on previous page.) This is more relevant for smaller residential structures that sit inside the lot away from the street than it is for larger mixed use buildings which more frequently are located directly adjacent to rights of way.

Also, portions of attics with a low ceiling height are excluded from "floor area". These spaces are not counted as habitable area per the building code, and with the low headroom, they do not substantially increase a building's height or bulk.

Figure 910-20 Floor Area in Attics

This new figure shows what is and what is not floor area in an attic space. Where the ceiling is higher than 6'8" tall, that portion of the room is counted.

Chapter 3, Section 305 of the Oregon Residential Specialty Code

305.1 Minimum height.

Habitable space, hallways, bath-rooms, toilet rooms, laundry rooms and portions of basements containing these spaces shall have a ceiling height of not less than 7 feet (2134 mm).

Exceptions

2. For rooms with sloped ceilings, at least 50 percent of the required floor area of the room must have a ceiling height of at least 7 feet (2134 mm) and no portion of the required floor area may have a ceiling height of less than 5 feet (1524 mm).
4. Conversion of existing nonhabitable spaces, such as a basement or attic, to habitable space, shall provide a minimum 6 feet, 8 inch (2032 mm) ceiling height for flat ceilings or the portion required under Exception 2 above.

Garage. The definition is being amended to include a triplex and fourplex, which were both previously defined as multi-dwelling structures. This will facilitate applying standards for garages to triplexes and fourplexes rather than applying the standards for parking structures.

Grade. The definition of grade is being simplified as part of related changes to the definition of height. The amendments clarify that grade is the final (altered) elevation, not the pre-development site elevation. This definition also no longer aligns with the building code definition of grade (or "grade plane"), so reference to the Oregon Structural Specialty Code is being removed.

Chapter 2, Section 202 of the 2014 Oregon Structural Specialty Code

GRADE PLANE. A reference plane representing the average of finished ground level adjoining the building at *exterior walls*. Where the finished ground level slopes away from the *exterior walls*, the reference plane shall be established by the lowest points within the area between the building and the *lot line* or, where the *lot line* is more than 6 feet (1829 mm) from the building, between the building and a point 6 feet (1829 mm) from the building.

Floor Area. The total area of all floors of a building. Floor area is measured for each floor from the exterior faces of a building or structure. Floor area includes stairwells, ramps, shafts, chases, and the area devoted to garages and structured parking. Floor area does not include the following:

- Areas where the elevation of the floor is 4 feet or more below the adjacent right-of way;
- Basements;
- Portions of attics where the finished ceiling height is less than 6 feet 8 inches. See Figure 910-20;
- Roof area, including roof top parking;
- Roof top mechanical equipment; and
- Roofed porches, exterior balconies, or other similar areas, unless they are enclosed by walls that are more than 42 inches in height, for 75 percent or more of their perimeter.

See also Net Building Area, Gross Building Area

Figure 910-20
Floor Area in Attics

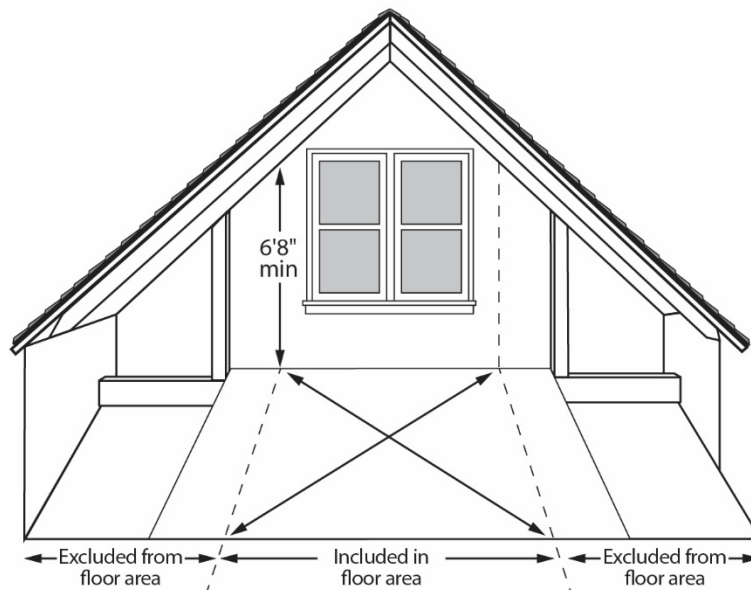

Garage. A covered structure that is accessory to a use in a house, attached house, duplex, triplex, fourplex, manufactured dwelling, or houseboat, and that:

- Is designed to provide shelter for vehicles;
- Is connected to a right-of-way by a driveway; and
- Has an opening that is at least 8-feet wide.

Carports are considered garages. Floor area adjacent to the space designed to provide shelter for vehicles, if not entirely separated from the garage area by floor-to-ceiling walls, is considered part of the garage. A garage may be attached to or detached from another structure. See also Structured Parking.

Grade. The final elevation of the ground. ~~The lowest point of elevation of the finished surface of the ground, paving, or sidewalk within the area between the building and the property line or, when the property line is more than 5 feet from the building, between the building and a line 5 feet from the building. This is the definition used in the Oregon Structural Specialty Code (the Uniform Building Code as amended by the State.)~~

Commentary

Lot. Clarification is being added that a lot may be considered more than one type of lot. For example, a corner lot may also be a through lot. Moreover, an adjusted lot can be a corner lot, a through lot, or a flag lot.

New Narrow Lot. The definition of new narrow lot is being deleted because development standards for narrow lots will no longer be based on when a narrow lot was created. See proposed amendments to 33.110.260, Additional Development Standards for Narrow Lots.

Lot. A lot is a legally defined piece of land other than a tract that is the result of a land division. This definition includes the State definition of both lot, (result of subdividing), and parcel, (result of partitioning). See also, Ownership and Site. A lot can be more than one type of lot:

- **Adjusted Lot.** A lot that has had one or more of its lot lines altered through ~~an approved property line adjustment or through~~ a deed, or other instrument relocating a property line, recorded with the appropriate county recorder prior to July 26, 1979, or through an approved property line adjustment. An adjusted lot may have equal or larger lot area than the original lot. An adjusted lot may have smaller lot area than the original lot, but must have a lot area that is more than 50% percent of the original lot area. Portions of an original lot that are 50% percent or less of the original lot area are defined as lot remnants. See Figures 910-17 and 910-18.
- **Corner Lot.** A lot that has frontage on more than one intersecting street, and where the lot frontages intersect. A street that curves with angles that are 120 degrees or less, measured from the center line of the street, is considered two intersecting streets for the purpose of evaluating whether a lot is a corner lot. See Figure 910-4.
- **Flag Lot.** A lot with two distinct parts (see Figure 910-5):
 - The flag, which is the only building site; and is located behind another lot; and
 - The pole, which connects the flag to the street; provides the only street frontage for the lot; and at any point is less than the minimum lot width for the zone.
- ~~**New Narrow Lot.** A lot that was created by a land division submitted after June 30, 2002, and:~~
 - ~~— Is in the R10 through R5 zone and does not meet the minimum lot width standard of 33.610.200.D.1; or~~
 - ~~— Is in the R2.5 zone and does not meet the minimum lot width standard of 33.611.200.C.1.~~
- **Through Lot.** A lot that has frontage on two streets, and where the lot frontages do not intersect. See Figure 910-4.

Commentary

Non-conforming development

Provisions in 33.258 allow non-conforming development to be rebuilt when destroyed by accidental causes (e.g. fire). The qualification that non-conforming development excludes existing buildings that are over a certain size (when that size is prohibited) is confusing and not intended to prevent existing buildings that exceed FAR limits from being rebuilt. Therefore, this statement is deleted.

Residential Structure Types

Accessory Dwelling Unit. The amendments to the definition of accessory dwelling unit reflect the fact that other amendments in this proposal will allow ADUs to be added to duplexes and to sites with detached single-dwelling structures approved through a Planned Development. The definition focuses on the subordinate nature of the ADU, rather than with what structure type it is being created.

Fourplex. A new definition of fourplex is being added because the single-dwelling zone Residential Infill Options will allow fourplexes (four units in one structure) on some R2.5, R5, and R7 lots.

Multi-Dwelling development. The example in the definition is removed because it creates confusion. The terms "house" and "duplex" are defined as structures located on their own lots. Therefore, the statement that a "duplex in front with either 1 or more single dwelling houses behind or 1 or more duplex units or multi-dwelling structures behind " is not technically accurate. The moment a separate primary unit in a separate building is added to a site with a house or duplex, the site is considered multi-dwelling development.

Multi-Dwelling Structure. The definition is being changed to reflect that triplexes and fourplexes are no longer defined as a multi-dwelling structure type, but remain their own distinct structure type, like "duplexes". This makes these residential structure types mutually exclusive and removes overlap.

Triplex. Triplexes are not a new residential structure type, but they had previously been considered a subset of multi-dwelling structures. They were redefined as their own structure type, but continue to be defined as three dwelling units in one structure on a lot.

Structured Parking. The revisions to the definition of "garage" added triplexes and fourplexes. Consequently, these residential structure types are being identified as not being associated with "Structured parking".

Nonconforming Development. An element of a development, such as a setback, height, or parking area, that was created in conformance with development regulations but which subsequently, due to a change in the zone or zoning regulations, is no longer in conformance with the current applicable development standards. ~~Nonconforming development includes development that is over a maximum allowed building size, as long as the development does not include a building size that is specifically prohibited by the current development standards.~~

Residential Structure Types

- **Accessory Dwelling Unit.** An additional second dwelling unit created on a lot with a primary dwelling unit, house, attached house, or manufactured home. The second unit is ~~created auxiliary to, and is always smaller than the primary dwelling unit except when the accessory dwelling unit is in an existing basement house, attached house, or manufactured home.~~ The accessory dwelling unit includes its own independent living facilities including provision for sleeping, cooking, and sanitation, and is designed for residential occupancy by one or more people, independent of the primary dwelling unit. Kitchen facilities for cooking in the unit are described in Section 29.30.160 of Title 29, Property and Maintenance Regulations. The unit may have a separate exterior entrance or an entrance to an internal common area accessible to the outside.
- **Attached Duplex.** [no change]
- **Attached House.** [No change]
- **Duplex.** [No change]
- **Dwelling Unit.** [No change]
- **Fourplex.** A structure that contains four primary dwelling units on one lot. Each unit must share a common wall or common floor/ceiling with at least one other unit.
- **Group Living Facility.** [No change]
- **House.** [No change]
- **Houseboat Moorage.** [No change]
- **Manufactured Dwelling.** [No change]
- **Multi-Dwelling Development.** A grouping of individual structures where each structure contains 1 or more dwelling units. The land underneath the structures is not divided into separate lots. ~~A multi-dwelling development project may include an existing single dwelling detached building with 1 or more new detached structures located to the rear or the side of the existing house. It might also include a duplex in front with either 1 or more single dwelling houses behind or 1 or more duplex units or multi-dwelling structures behind.~~ The key characteristic of this housing type is that there is no requirement for the structures on the sites to be attached.
- **Multi-Dwelling Structure.** A structure that contains ~~three~~five or more dwelling units that share common walls or floor/ceilings with one or more units. The land underneath the structure is not divided into separate lots. Multi-dwelling includes structures commonly called garden apartments, apartments, and condominiums.
- **Single Room Occupancy Housing (SRO).** [No change]
- **Triplex.** ~~A multi-dwelling structure that contains three primary dwelling units on one lot. Each unit must share a common wall or common floor/ceiling with at least one other unit.~~

Structured Parking. A covered structure or portion of a covered structure that provides parking areas for motor vehicles. Parking on top of a structure—where there is gross building area below the parking, but nothing above it—is structured parking. The structure can be the primary structure for a Commercial Parking facility or be accessory to multi-dwelling residential, commercial, employment, industrial, institutional, or other structures. A structure that is accessory to a single-dwelling residential structure (including houses, attached houses, duplexes, triplexes, fourplexes, manufactured dwellings, or houseboats) is a garage and is not included as structured parking. See also Garage, Parking Area, and Underground Parking.

Commentary

33.930.050 Measuring Height

The changes to the measurement of building height are significant. They aim to close potential loopholes that have allowed buildings to be taller than desired. In the past, pushing the envelope on base zone height limits has not been an issue because new development was not maximizing development allowances on sites. Recently however, new development frequently maximizes the development to compensate for the increased land cost. It is relatively frequent for development to exceed the height limit by exposing the basement or building full-floor "dormers" to create a 4 story house. The amendments to this section are intended to ensure that the height limit keeps structures at $2\frac{1}{2}$ story in the single dwelling zones.

The new height measurement methodology maintains the current paradigm of measuring height between a base point and a top reference point determined by the type of roof.

Height is still measured from the finished grade—not the pre-development grade—as pre-development grade is difficult to verify once construction has begun, can create challenging design scenarios, and for sites with pre-existing development, raise questions about what "pre-development" grade is.

The most significant proposed change is switching from measuring from the *highest* point anywhere within a 5-foot distance from a building wall, to measuring from the *lowest* point along a perimeter line drawn 5 feet from the building wall. This ensures that the base point reference can't be artificially raised in one spot or along one side of a building to allow the entire building to be taller; the entire perimeter of the building would need to be raised. By using a perimeter line 5 feet from the building versus describing the entire area within 5 feet of the building, window wells and access stairs to basements can be excluded as the "lowest point" for calculating height provided these features do not extend beyond the 5-foot area.

An allowance is also provided for a 5-foot wide pedestrian only connection through the perimeter grade measurement line. If the lowest point is within this connection, the next lowest grade point is used. This is to provide connections between the street and basements on raised lots.

The changes also clarify that measured height is the greatest vertical distance between the two reference points. In other words, if a roof midpoint on the opposite side of a house is higher than the roof midpoint nearer to the lowest base point, the higher roof reference point is used.

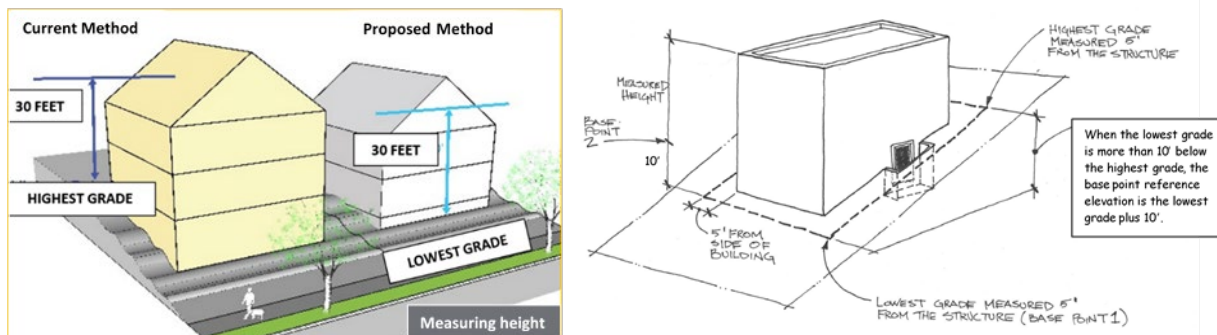

33.930 Measurements

930

33.930.050 Measuring Height

A. Measuring building height. The height of a building is the vertical distance between the base reference point and the highest roof-type reference point. The methods for establishing the base reference point are described in Paragraph A.1. Methods to establish the roof-type reference point are described in Paragraph A.2.

1. Base reference point.

a. In commercial/mixed use zones. In the commercial/mixed-use zones, when any portion of a building is within 25 feet of an existing or proposed sidewalk, the base reference point is determined using the method described in Subsubparagraphs A.1.a(1) and A.1.a(2). See Figure 930-25 and 930-26. If no portion of a building is within 25 feet of an existing or proposed sidewalk, the base reference point is determined using the method described in Subparagraph A.1.b.:

(1) Identify the lowest and highest grade of the sidewalk located within 25 feet of the building.

(2) Determine the base reference point:

- When the lowest grade of the existing or proposed sidewalk located within 25 feet of the building is not more than 10 feet below the highest grade of the sidewalk adjacent to the site within 25 feet of the building, the base reference point is the lowest grade of the sidewalk.
- When the lowest grade of the existing or proposed sidewalk located within 25 feet of the building is more than 10 feet below the highest grade of the sidewalk adjacent to the site within 25 feet of the building, the base reference point is the lowest grade of the sidewalk plus 10 feet.

Commentary

Roof Type Reference Point

The other significant change is the requirement to use the roof-type reference point that yields the highest measurement. Currently the average height of the highest gable is most commonly used to determine building height. However, if there is a smaller gable roof with an average height that is higher than the larger roof (by virtue of using averages) but that roof is not above the ridgeline of the larger roof, then the lower reference for the larger roof is used. Or if there is a shed roof dormer on a gable roof, but the shed roof doesn't project above the gable, then the midpoint of the gable is currently used. With this change, the reference point for each roof would be compared to see which yields the highest measurement (see example on next commentary page).

The amendments also delete the differentiation between less steep roofs (<12:12 pitch) and very steep roofs (12:12 pitch and greater). Currently, the code differentiates measurement methods between gable and hip roofs with less than 12:12 pitch (measure to the midpoint), from those with 12:12 and greater roof pitch (measure to the peak). The code also requires that the measurement for pyramidal shaped roofs be to the peak of the roof, even though the difference between pyramidal and gable/hipped roofs is nearly imperceptible from the ground.

These changes treat these roof types the same by measuring to the midpoint in all cases. This allows for steeper pitched roofs that may be taller, but the building profile is typically less bulky than buildings with lower pitched roofs. This, along with FAR limits that count tall attic spaces will work together to reduce the overall building bulk.

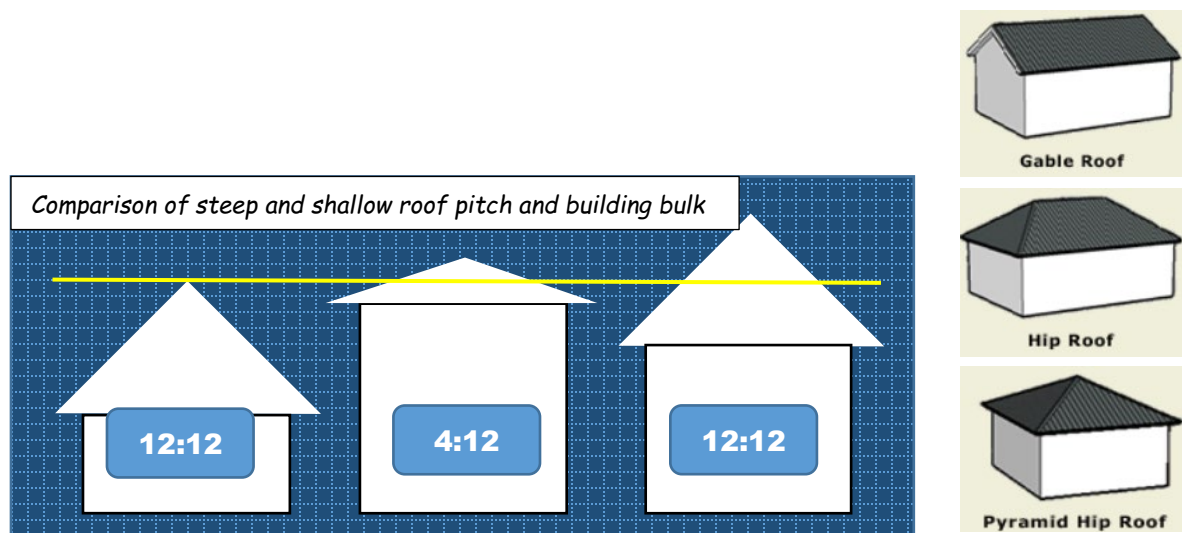

b. In all other zones, the base reference point is determined using the method described in Subparagraphs A.1.b(1) and A.1.b(2). See Figure 930-7:

(1) Identify the lowest and highest grade exactly 5 feet from the building. To establish lowest and highest grade, draw a line exactly 5 feet from all sides of the building and identify the lowest and the highest grade along the line. Exclude from the identification of lowest grade pedestrian-only paths that are no more than 5 feet wide that provide access from the street to an entrance into the building. If the property line is less than 5 feet from any side of the building, the line must follow the property line for the segment where the property line is less than 5 feet from the building.

(2) Determine the base reference point:

- When the lowest grade is not more than 10 feet below the highest grade exactly 5 feet from the building, the lowest grade is the base reference point.
- When the lowest grade is more than 10 feet below the highest grade exactly 5 feet from the building, the base reference point is the lowest grade plus 10 feet.

2. Roof-type reference point. The methods to determine the roof-type reference point are described below and are shown in Figure 930-5. There may be multiple roof-type reference points on a building:

- Flat roof (pitch is 2 in 12 or less): Measure to the highest point of the roof except in the residential zones where the measurement is to the top of the parapet, or if there is no parapet, to the highest point of the roof.
- Mansard roof: Measure to the deck line.
- Gabled, hipped, gambrel, or pyramidal roof: Measure to the average height of the gable.
- Other roof types such as domed, shed, or vaulted shapes: Measure to the highest point.
- Stepped or terraced building: Measure to the highest point of any segment of the building.

Commentary

Figure 930-5

A small refinement was made to this drawing to show that the height for sloped roofs is measured at the point where the wall intersects with the roof plane, not the upper edge of the eave.

Figure 930-6

This figure has been revised to incorporate the restructured height measurement language which no longer refers to "base point 1" and "base point 2"

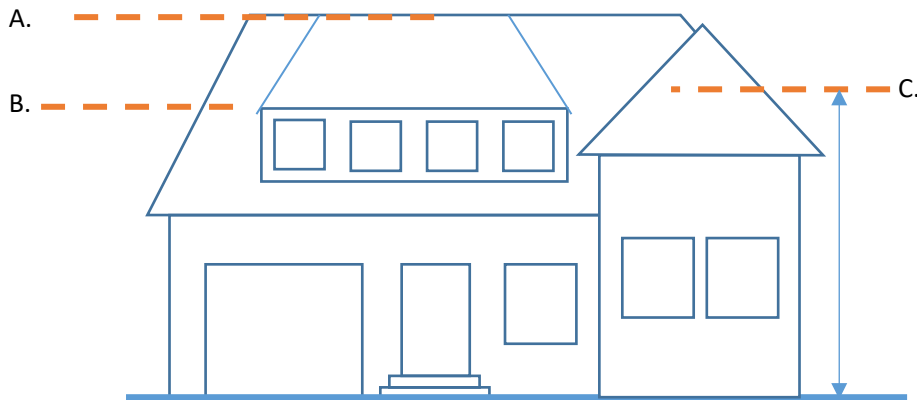

Dormer shed roof (A.) this is not included in height calculation in single dwelling base zone, if it meets the standards of 33.110.220.C.2

Main gable roof (B.) even though the ridge is highest, its midpoint is not.

Small gable roof (C.) even though this roof ridgeline is lower than the larger gable, the midpoint of this roof is the highest roof reference point, therefore this point is used for height calculation.

Language to be **added** is underlined
Language to be **deleted** is shown in ~~strikethrough~~

Figure 930-5
Measuring Height – Roof Types

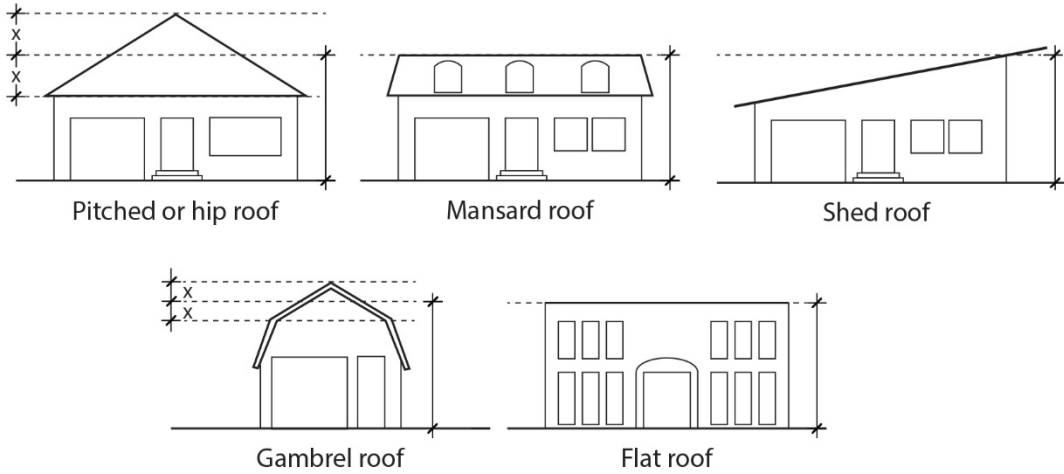
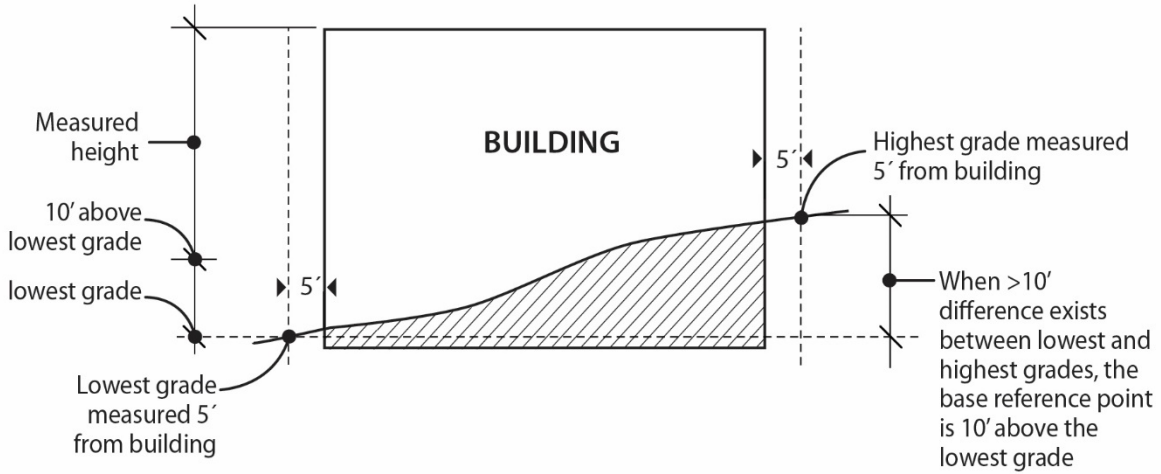

Figure 930-6
Measuring Height – Determining Base Reference Point



Commentary

Language to be **added** is underlined
Language to be **deleted** is shown in ~~strikethrough~~

Figure 930-25
Measuring Height – Commercial/Mixed Use Zones

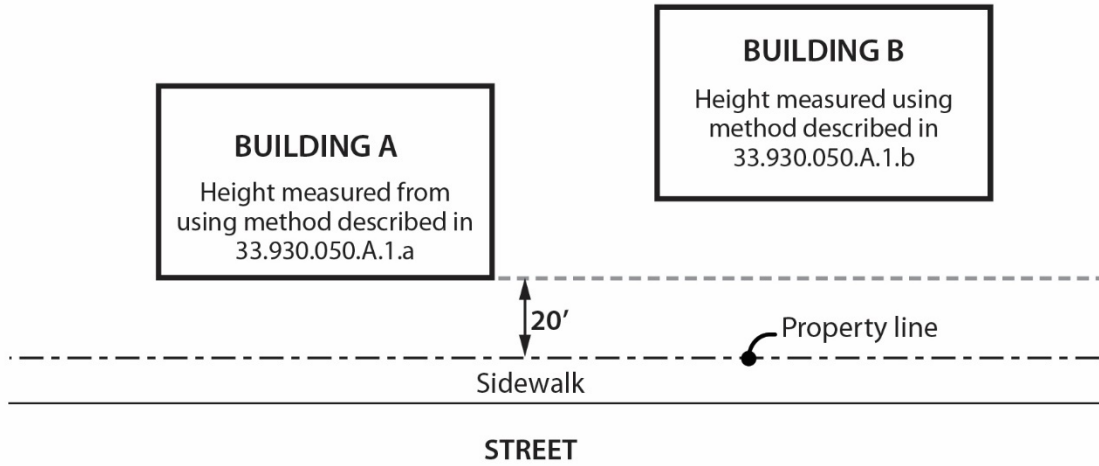
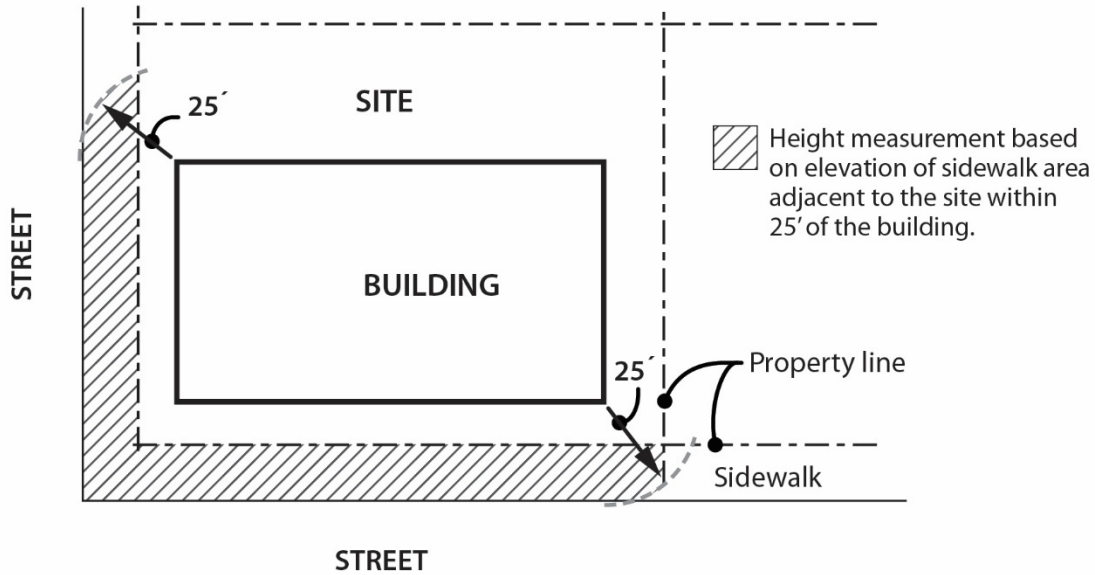

Figure 930-26
Measuring Height – Sidewalk Area Used for Height Measurement in Commercial/Mixed Use Zones



Commentary

33.930.050 Measuring Height

A. Measuring building height. Height of buildings is generally measured as provided in the Oregon Structural Specialty Code (the Uniform Building Code as amended by the State.) The height of buildings is the vertical distance above the base point described in Paragraphs A.1. or A.2., unless the site is in a commercial/mixed use zone, in which case the height of buildings is measured as described in Paragraph A.3. The base point used is the method that yields the greater height of building. Methods to measure specific roof types are shown below and in Figure 930-5:

- ~~Flat roof (pitch is 2 in 12 or less): Measure to the highest point of the roof except in the residential zones where the measurement is to the top of the parapet, or if there is no parapet, to the highest point of the roof.~~
 - ~~Mansard roof: Measure to the deck line.~~
 - ~~Gabled, hipped, or gambrel roof where roof pitch is 12 in 12 or less: Measure to the average height of the highest gable.~~
 - ~~Gabled or hipped roofs with a pitch steeper than 12 in 12: Measure to the highest point.~~
 - ~~Gambrel roofs where both pitches are steeper than 12 in 12: Measure to the highest point.~~
 - ~~Other roof shapes such as domed, shed, vaulted, or pyramidal shapes: Measure to the highest point.~~
 - ~~Stepped or terraced building: Measure to the highest point of any segment of the building.~~
1. ~~Base point 1. Base point 1 is the elevation of the highest adjoining sidewalk or ground surface within a 5 foot horizontal distance of the exterior wall of the building when such sidewalk or ground surface is not more than 10 feet above lowest grade. See Figure 930-6.~~
 2. ~~Base point 2. Base point 2 is the elevation that is 10 feet higher than the lowest grade when the sidewalk or ground surface described in Paragraph 1., above, is more than 10 feet above lowest grade. See Figure 930-7.~~
 3. ~~In the commercial/mixed use zones, the height measurement is based on the location of a building relative to a street lot line and the elevation of sidewalk area adjacent to the site, as follows:~~
 - a. ~~When any portion of a building is within 20 feet of a street lot line, the base point from which height is measured is described below. See Figure 930-25 and Figure 930-26:~~
 - (1) ~~Within 25 feet of the building, when the difference between the highest elevation and the lowest elevation of sidewalk is 10 feet or less, the base point is the highest elevation of the sidewalk; or~~
 - (2) ~~Within 25 feet of the building, when the difference between the highest elevation and the lowest elevation of sidewalk is more than 10 feet, the base point is a point 10 feet above the lowest elevation of the sidewalk.~~
 - b. ~~For all other buildings, or if no sidewalk exists or is proposed within 25 feet of the building, height is measured using the base points described in Paragraphs A.1. and A.2.~~

Commentary

Language to be **added** is underlined>
 Language to be **deleted** is shown in ~~strikethrough~~

Figure 930-5
Measuring Height — Roof Types

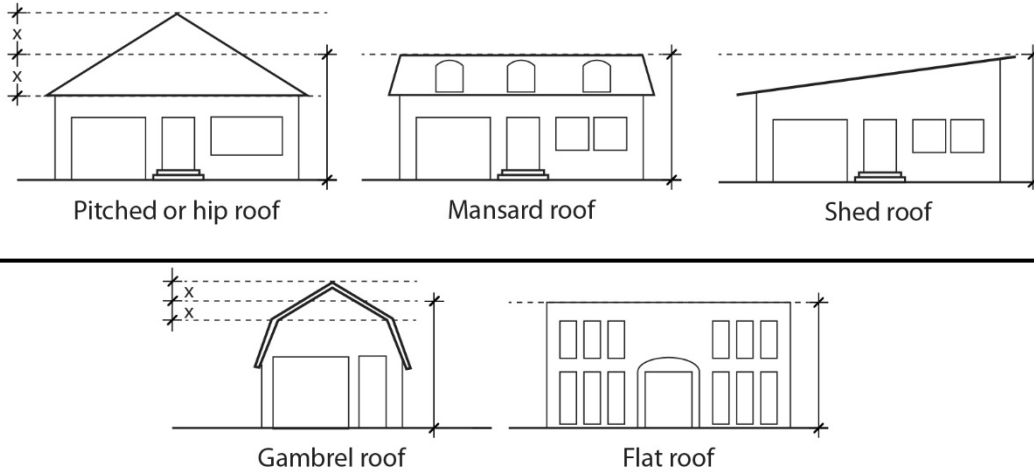
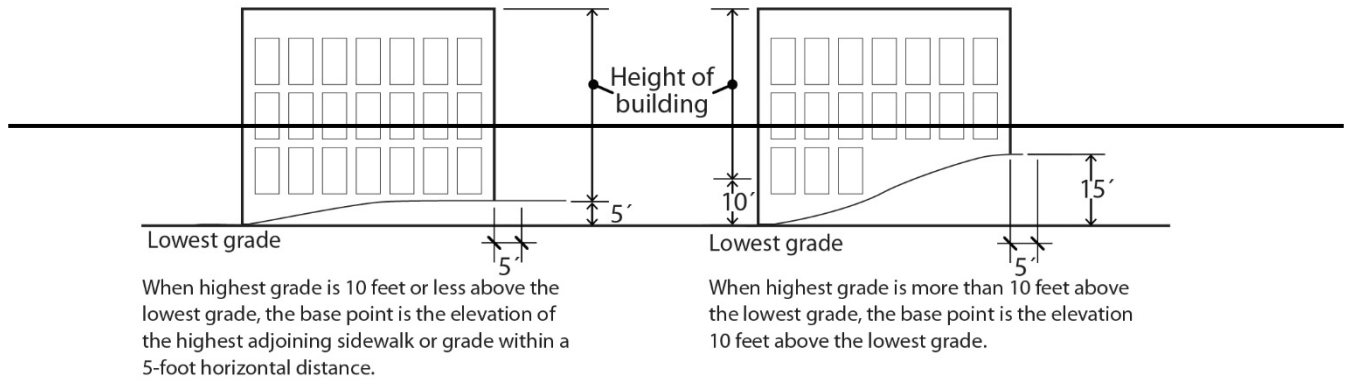

Figure 930-6 — ~~Figure 930-7~~
Measuring Height — Base Point 1 — ~~Measuring Height — Base Point 2~~



When highest grade is 10 feet or less above the lowest grade, the base point is the elevation of the highest adjoining sidewalk or grade within a 5-foot horizontal distance.

When highest grade is more than 10 feet above the lowest grade, the base point is the elevation 10 feet above the lowest grade.

Commentary

Language to be **added** is underlined
Language to be **deleted** is shown in ~~strikethrough~~

Figure 930-25
Measuring Height – Commercial/Mixed Use Zones

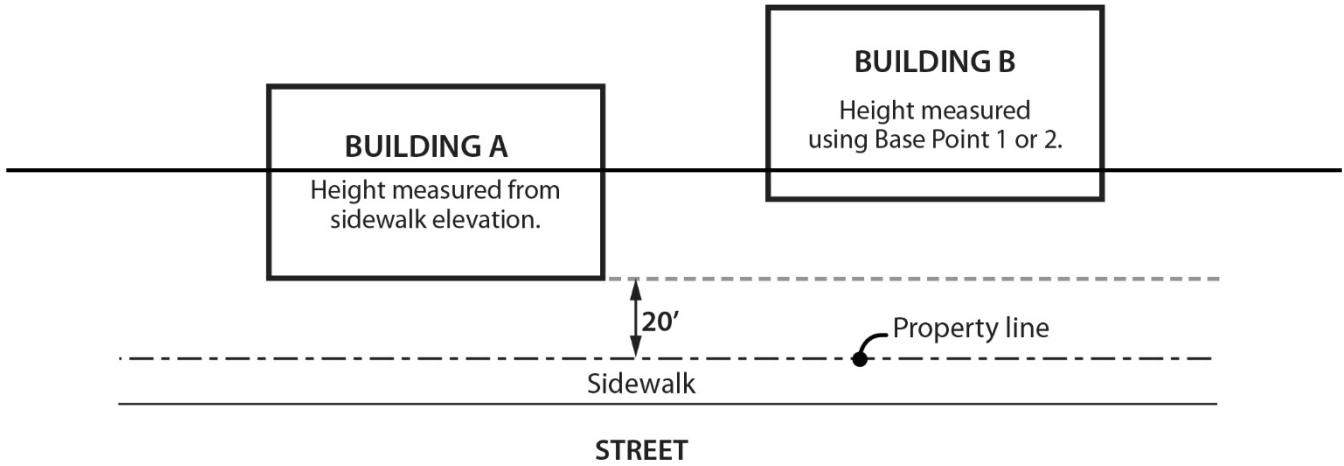
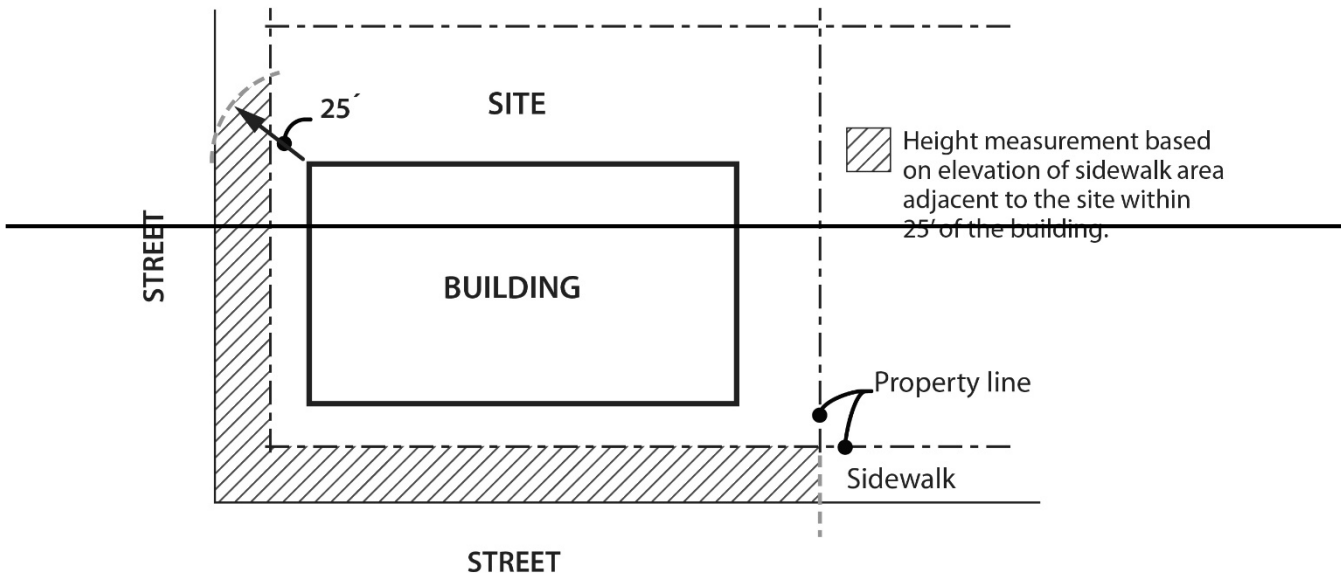

Figure 930-26
Measuring Height – Sidewalk Area Used for Height Measurement in Commercial/Mixed Use Zones



B. Measuring height of other structures. [No change]

Commentary

33.930.060 Determining Average Slope

The numbering for Subsection A was deleted as there is no longer a subsection B.

Figure 930-9 Calculating Average Slope

This figure was updated to show an irregular lot configuration, to clarify how measurements are made in these situations. The method was not changed.

33.930.060 Determining Average Slope

~~A. — Average slope used.~~ When calculating the slope of a lot an average slope is used based on the elevations at the corners of the lot. The average slope of a lot is calculated by subtracting the average elevation of the uphill lot line and the average elevation of the downhill lot line and dividing the sum by the average distance between the two lot lines. The average elevation of the uphill or downhill lot line is calculated by adding the elevations at the ends of the lot line and dividing by two. See Figure 930-9.

Figure 930-9
Calculating Average Slope

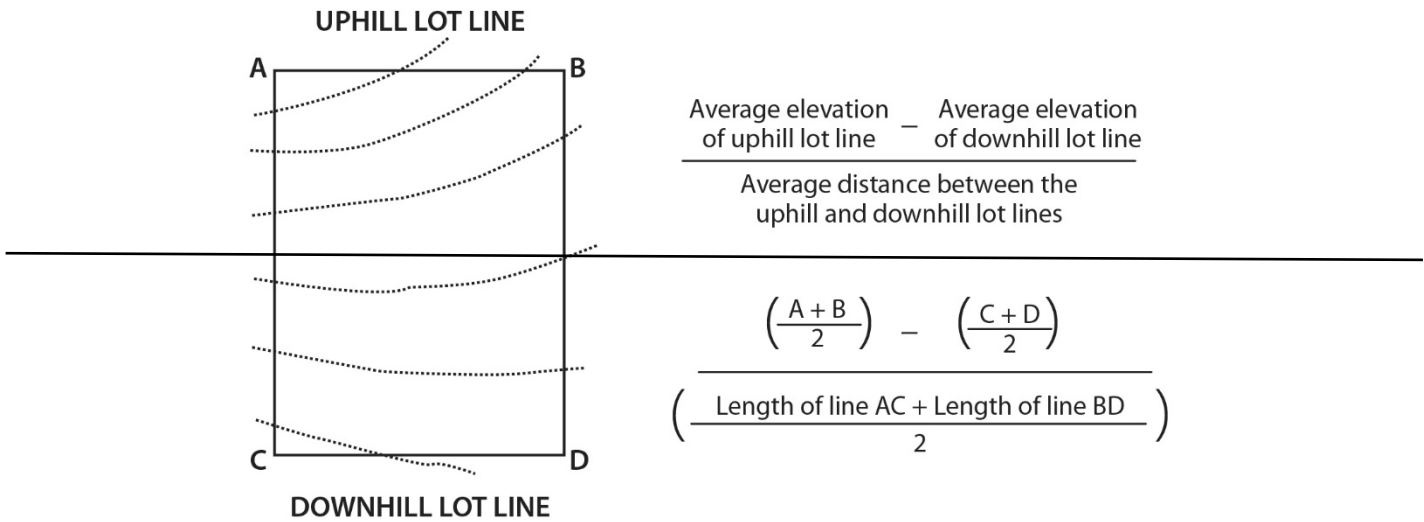
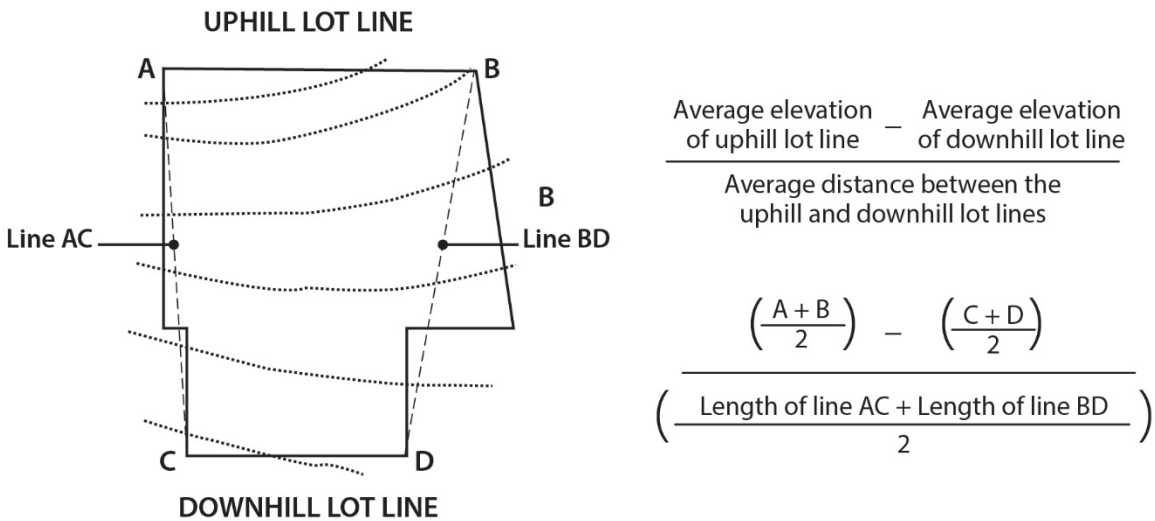

Figure 930-9
Calculating Average Slope



Commentary

33.930.100 Measuring Lot Widths

The Section title and Subsection B were changed to reflect that 33.930.103 addresses Lot Depths.

33.930.100 Measuring Lot Widths and ~~Depths~~

- A. Single-Dwelling zones.** In the single-dwelling zones, lot width is measured by placing a rectangle along the minimum front building setback line. Where the setback line is curved, the rectangle is placed on the line between the intersection points of the setback line with the side lot lines. See Figure 930-20.

The rectangle must have a minimum width equal to the minimum lot width specified for the zone in Chapters 33.610 and 33.611. The rectangle must have a minimum depth of 40 feet, or extend to the rear property line, whichever is less. The rectangle must fit entirely within the lot. See Figure 930-20.

- B. All other zones.** In all other zones, lot widths ~~and depths~~ are measured from the midpoints of opposite lot lines. See Figure 930-15.

Section 7: Comprehensive Plan Amendments

Chapter 10: Land Use Designations and Zoning

The following table compares the Comprehensive Plan Designation and Zoning Names for the single-dwelling and multi-dwelling zones, including pending changes proposed by the Better Housing by Design Project.

Replacing "single-dwelling" with a less specific "residential" designation reflects existing and new allowances for additional housing types beyond just a single house, for example accessory dwelling units, corner lot duplexes, as well as duplexes, triplexes and fourplexes in many areas of R2.5, R5, and R7 zones.

Comprehensive Plan Designation		Zoning Name and Symbol			
Current	Proposed	Current	Proposed	Short name Current/proposed	
Farm and Forest	Farm and Forest	Residential Farm/Forest	No change	RF	No change
Single Dwelling 20,000	Residential 20,000	Residential 20,000	No change	R20	
Single Dwelling 10,000	Residential 10,000	Residential 10,000	No change	R10	
Single Dwelling 7,000	Residential 7,000	Residential 7,000	No change	R7	
Single Dwelling 5,000	Residential 5,000	Residential 5,000	No change	R5	
Single Dwelling 2,500	Residential 2,500	Residential 2,500	No change	R2.5	
Multi Dwelling 3,000	Multi-Dwelling - Neighborhood	Residential 3,000	Residential Multi-Dwelling 1	R3	RM1
Multi Dwelling 2,000		Residential 2,000		R2	
Multi Dwelling 1,000	Multi-Dwelling - Corridor	Residential 1,000	Residential Multi-Dwelling 2	R1	RM2
High Density Multi-Dwelling	Multi-Dwelling - Urban Center	High Density Residential (2:1 FAR)	Residential Multi-Dwelling 3	RH	RM3
		High Density Residential (4:1 FAR)	Residential Multi-Dwelling 4		RM4
Central Residential	Central Residential	Central Residential	Central Residential	RX	RX

Chapter 10 - Land use designations and zoning

The Comprehensive Plan Map is one of the Comprehensive Plan's implementation tools. The map includes land use designations, which are used to carry out the Comprehensive Plan. The land use designation that best implements the goals and policies of the Plan is applied to each area of the city. This section contains general descriptions of the land use designations.

Each description includes:

- Type of place or Pattern Area for which the designation is intended.
- General use and intensity expected within the area. In some cases, alternative development or infill options allowed in single-dwelling residential zones (e.g. duplexes and attached houses on corner lots; accessory dwelling units) may allow additional residential units beyond the general density described below.
- Level of public services provided or planned.
- Level of constraint.

Policy 10.1, Land use designations. Apply a land use designation to all land and water within the City's Urban Services Boundary. Apply the designation that best advances the Comprehensive Plan goals and policies. The land use designations are shown on the adopted Land Use Map and on official Zoning Maps.

1. **Open Space** [No change]
2. **Farm and Forest** This designation is intended for agricultural and forested areas far from centers and corridors, where urban public services are extremely limited or absent, and future investment to establish an urban level of public services is not planned. Areas within this designation generally have multiple significant development constraints that may pose health and safety risks if the land were more densely developed. The designation can be used where larger lot sizes are necessary to enable on-site sanitary or stormwater disposal. It also may be used in locations that may become more urban in the future, but where plans are not yet in place to ensure orderly development. Agriculture, forestry, and very low-density single-dwelling residential will be the primary uses. The maximum density is generally 1 ~~unit~~lot per 2 acres. The corresponding zone is RF.
3. **Single-Dwelling Residential — 20,000** This designation is intended for areas that are generally far from centers and corridors where urban public services are extremely limited or absent, and future investments in urban public services will be limited. Areas within the designation generally have multiple significant development constraints that may pose health and safety risks if the land were more densely developed. Very low-density single- dwelling residential and agriculture will be the primary uses. The maximum density is generally 2.2 ~~units~~lots per acre. The corresponding zone is R20.
4. **Single-Dwelling Residential — 10,000** This designation is intended for areas far from centers and corridors where urban public services are available or planned but complete local street networks or transit service is limited. This designation is also intended for areas where ecological resources or public health and safety considerations warrant lower densities. Areas within this designation generally have development constraints, but the constraints can be managed through appropriate design during the subdivision process. Single- dwelling residential will be the primary use. The maximum density is generally 4.4 ~~units~~lots per acre. The corresponding zone is R10.

Language to be **added** is underlined
 Language to be **deleted** is shown in ~~strikethrough~~

5. ~~Single Dwelling Residential~~ — **7,000**. This designation is intended for areas that are not adjacent to centers and corridors, where urban public services are available or planned, but complete local street networks or transit service is limited. This designation is also intended for areas where ecological resources or public health and safety considerations warrant lower densities. Areas within this designation may have minor development constraints, but the constraints can be managed through appropriate design during the subdivision process. This designation may also be applied in areas where urban public services are available or planned, but the development pattern is already predominantly built-out at 5 to 6 units per acre. Single-dwelling residential will be the primary use, but other housing types are also allowed. The maximum density is generally 6.2 ~~units~~ lots per acre. The corresponding zone is R7.

6. ~~Single Dwelling Residential~~ — **5,000**. This designation is Portland’s most common pattern of single-dwelling development, particularly in the city’s inner neighborhoods. It is intended for areas where urban public services, generally including complete local street networks and access to frequent transit, are available or planned. Areas within this designation generally have few or very minor development constraints. Single-dwelling residential will be the primary use, but other housing types are also allowed. The maximum density is generally 8.7 ~~units~~ lots per acre. The corresponding zone is R5.

7. ~~Single Dwelling Residential~~ — **2,500**. This designation allows a mix of housing types that are single-dwelling in character. This designation is intended for areas near, in, and along centers and corridors, near transit station areas, where urban public services, generally including complete local street networks and access to frequent transit, are available or planned. Areas within this designation generally do not have development constraints. This designation often serves as a transition between mixed use or multi-dwelling designations and lower density single dwelling designations. The maximum density is generally 17.4 ~~units~~ lots per acre. The corresponding zone is R2.5.

8. – 22. [No change]

Figure 10-1. Corresponding and Allowed Zones for Each Land Use Designation

LU Designation	Corresponding Zone(s)	Non-corresponding zone(s) that are allowed
Open Space	OS	none
Farm and Forest	RF	OS
Single Dwelling Residential 20,000	R20	RF, OS
Single Dwelling Residential 10,000	R10	R20, RF, OS
Single Dwelling Residential 7,000	R7	R10, R20, RF, OS
Single Dwelling Residential 5,000	R5	R7, R10, R20, RF, OS
Single Dwelling Residential 2,500	R2.5	R5, R7, R10, R20, RF, OS

[No change to remainder of Figure 10-1]

Glossary

Accessory Dwelling Unit

The term accessory dwelling unit is used several times in the comprehensive plan to convey additional housing types that should be encouraged.

The Comprehensive Plan glossary notes that "Words not included in this Glossary are defined by their dictionary meaning, or in some cases, by their meaning in state or federal law."

The term Accessory Dwelling Unit was not previously defined in state law, but it subsequently has been:

ORS 197.312(5)(b): "accessory dwelling unit" means an interior, attached or detached residential structure that is used in connection with or that is accessory to a single-family dwelling.

This meaning is sufficient and does not conflict with the meaning in the Comprehensive Plan, so the redundancy is being deleted.

Language to be **added** is underlined
Language to be **deleted** is shown in ~~strikethrough~~

Glossary

The Comprehensive Plan uses clear, everyday language as much as possible. Words and terms in the Glossary have the specific meaning stated below when used in the Comprehensive Plan, unless the context clearly indicates another meaning. Words not included in this Glossary are defined by their dictionary meaning, or in some cases, by their meaning in state or federal law.

~~**Accessory dwelling unit (ADU):** A second dwelling unit on a lot with a house, attached house, or manufactured home. The second unit is created auxiliary to, and is always smaller than, the house, attached house, or manufactured home. The unit includes its own independent facilities including provisions for sleeping, cooking, and sanitation, and is designed for occupancy by one or more people independent of the primary dwelling unit.~~

