



BLOCK 102

DESIGN DRAWINGS

- 1. Floor Plans*
- 2. Elevations*
- 3. Sections*
- 4. Wall Sections: Composite Sheets*
- 5. Exterior Features*
- 6. Material Palette*
- 7. Exterior Lighting Plan*
- 8. Loading Dock*
- 9. Renderings*

BLOCK 102



11 FLOORS

163
For-rent housing units

170,964
GSF of housing

11,427
GSF of retail

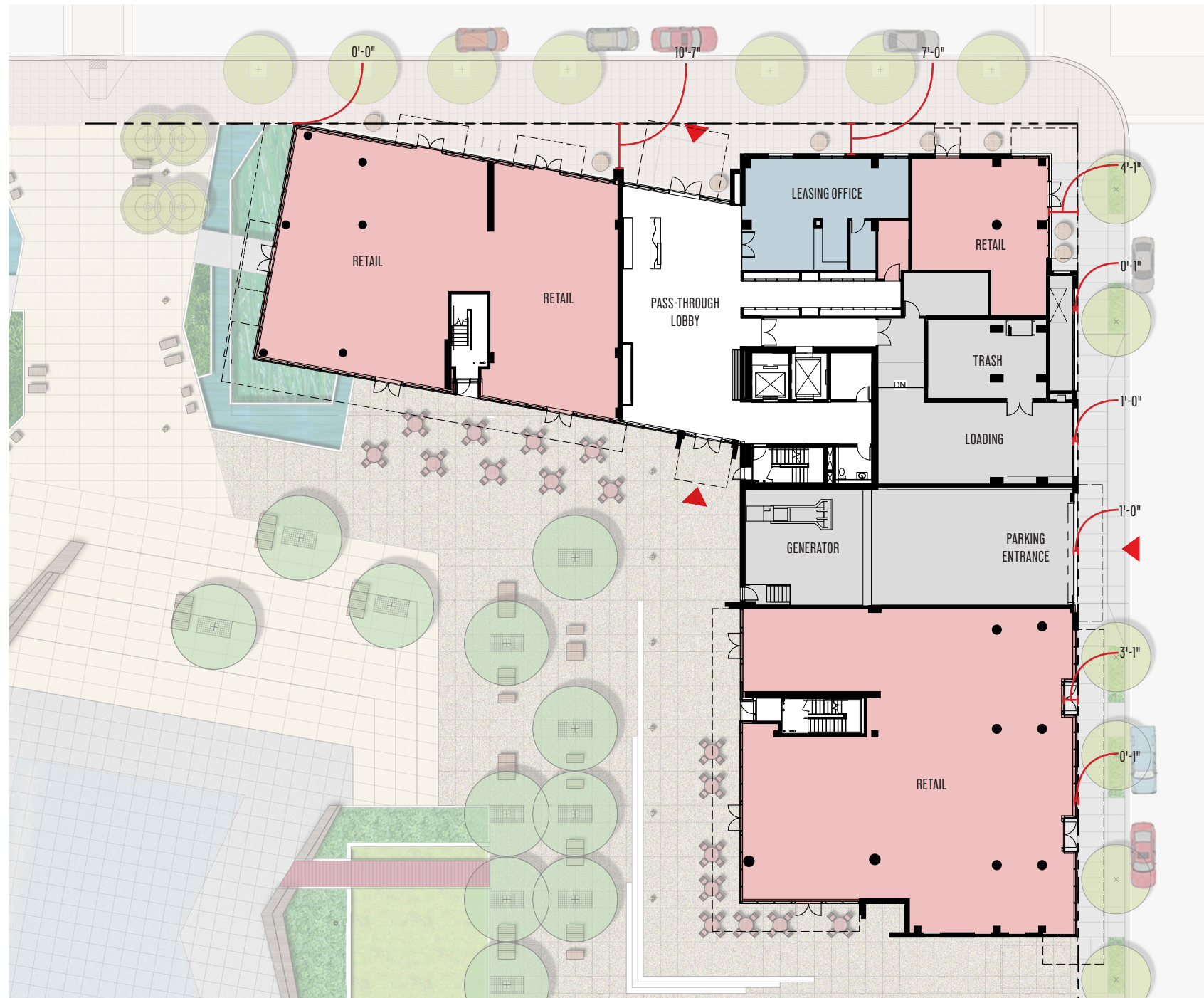

11,427
GSF of retail

- APARTMENTS
- RETAIL
- AMENITY
- SERVICE/SUPPORT
- BUILDING SERVICES

GROUND FLOOR PLAN



- 23
For-rent housing units
- APARTMENTS
 - RETAIL
 - AMENITY
 - SERVICE/SUPPORT
 - BUILDING SERVICES

TYPICAL PODIUM PLAN - FLOORS 04-06



TERRACE PLAN - FLOOR 07

13
For-rent housing units

- APARTMENTS
- RETAIL
- AMENITY
- SERVICE/SUPPORT
- BUILDING SERVICES



TYPICAL TOWER PLAN - FLOORS 08 -10



AMENITY PLAN - FLOOR 11



ROOF PLAN - FLOOR 12



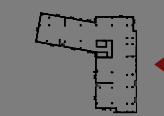

EAST ELEVATION



ALUM. FRAMED CURTAIN WALL W/ CLEAR GLASS (DARK BRONZE)

METAL PANEL (DARK BRONZE, MATTE)

ALUM. FRAMED CURTAIN WALL W/ CLEAR GLASS

STACKED BOND BRICK (EBONY, SMOOTH)

GFRC (BEIGE, BRUSHED)

102 - 12

102 - 10

GLASS GUARDRAIL W/ TOP RAIL

PRECAST CONCRETE (WHITE, HONED)

102 - 13

102 - 8/9

ALUM. FRAMED CURTAIN WALL W/ CLEAR GLASS (DARK BRONZE)

STEEL & GLASS CANOPY (DARK BRONZE)

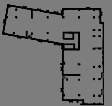

SOUTH ELEVATION

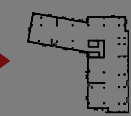

WEST ELEVATION

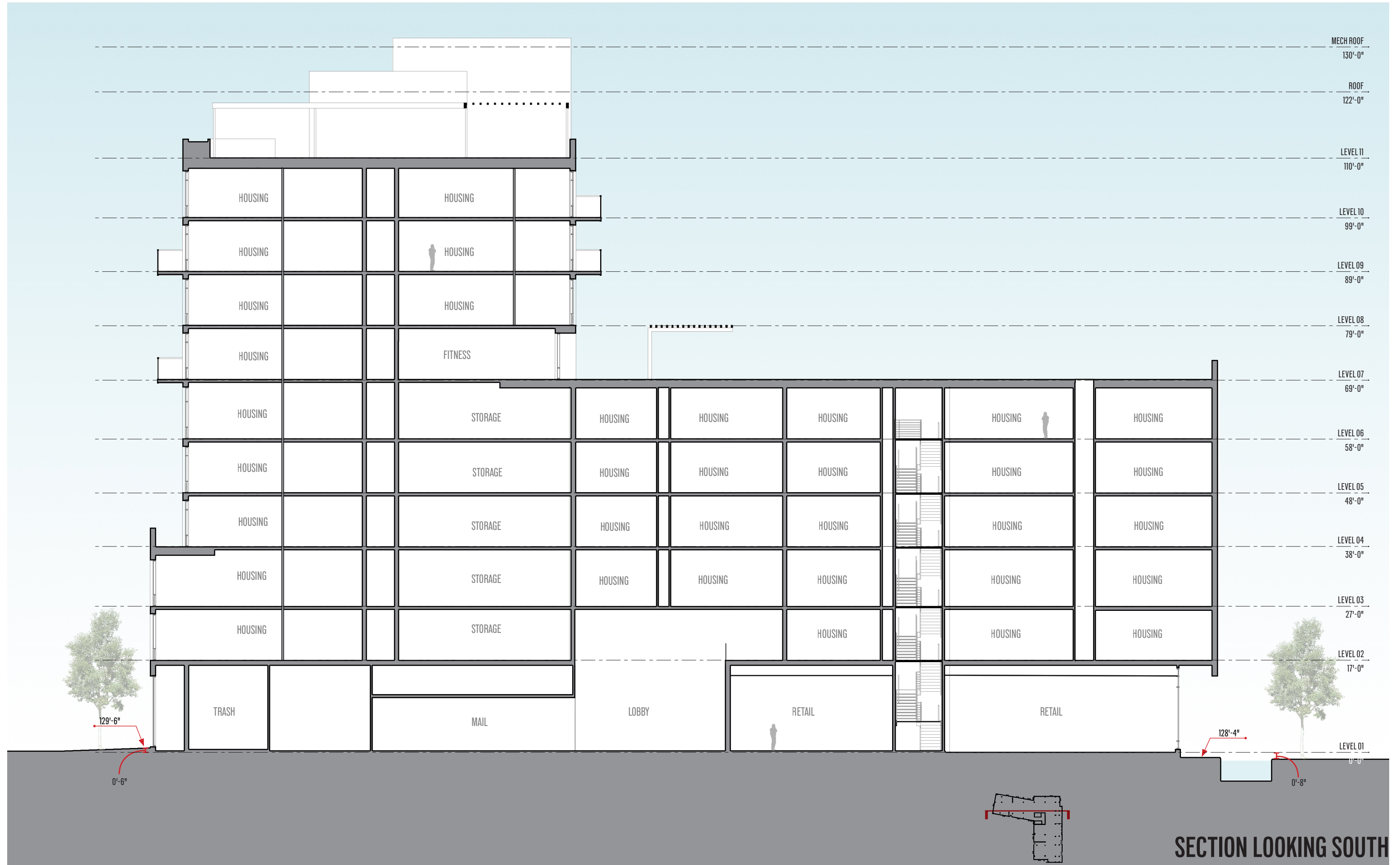

SECTION LOOKING SOUTH

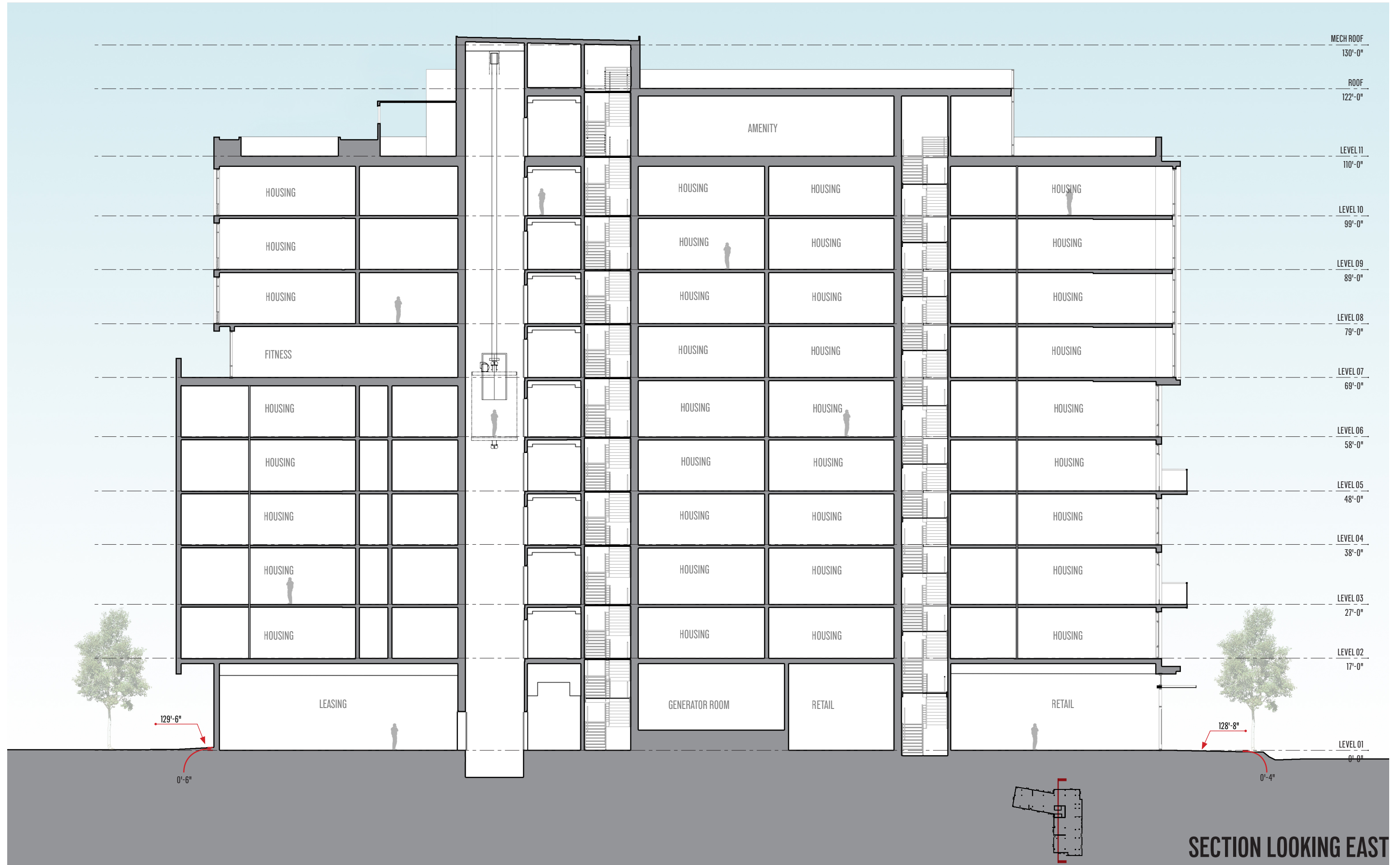



- METAL PANEL (DARK BRONZE, MATTE)
- ALUM. PUNCH WINDOW W/ CLEAR GLASS (DARK BRONZE)
- GLASS GUARDRAIL W/ TOP RAIL
- PAINTED METAL FASCIA
- GFRC (BEIGE, BRUSHED)
- METAL LOUVER (DARK BRONZE)
- STEEL & GLASS ENTRY CANOPY (PAINTED WHITE)
- METAL PANEL (WHITE, MATTE)
- ALUM. FRAMED DOOR W/ CLEAR GLASS (DARK BRONZE)
- STACKED BOND BRICK (EBONY, SMOOTH)

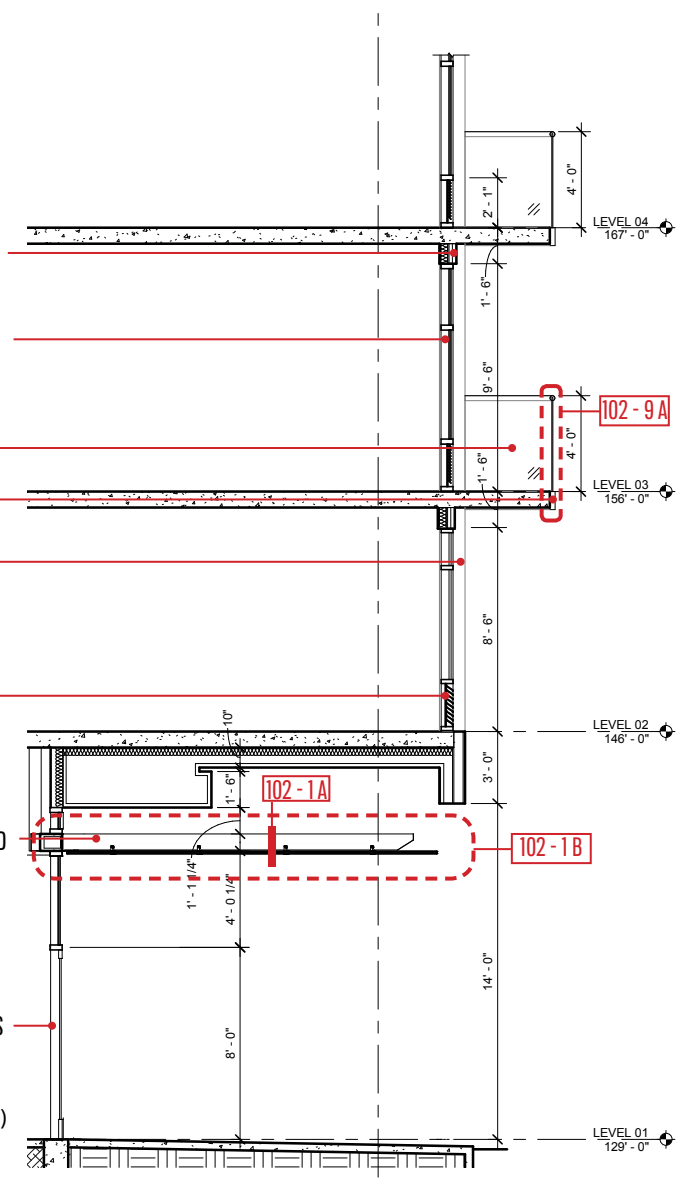

STEEL & GLASS ENTRY CANOPY

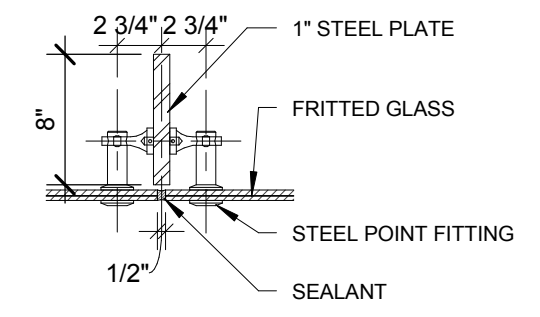

A. ENTRY CANOPY DETAIL AT STEEL PLATE/FITTING
1" = 1'-0"

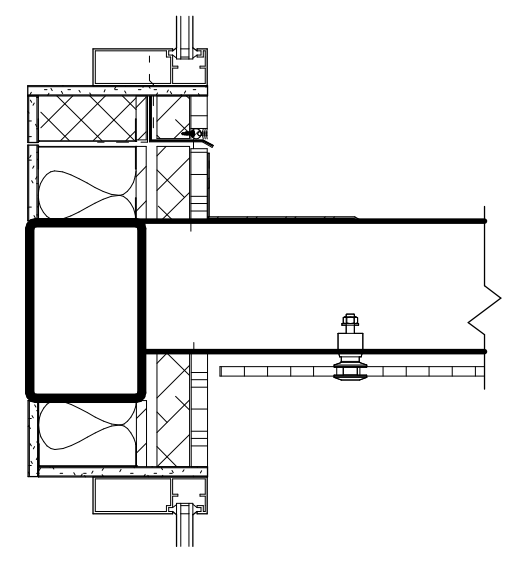

B. ENTRY CANOPY SECTION DETAIL
1" = 1'-0"

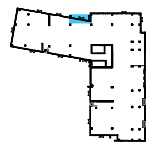
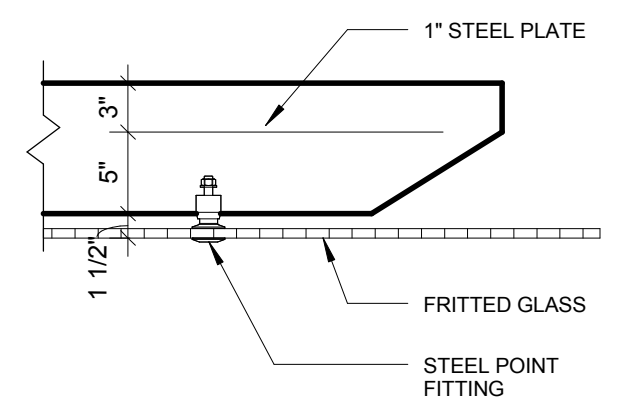

NORTH ENTRY _ DETAIL: 102 - 1



- GLASS GUARDRAIL W/ TOP RAIL
- PAINTED METAL FASCIA
- GFRc (BEIGE, BRUSHED)
- METAL LOUVER (DARK BRONZE)
- METAL PANEL (DARK BRONZE, MATTE)
- ALUM. PUNCH WINDOW W/ CLEAR GLASS (DARK BRONZE)
- METAL LOUVER (DARK BRONZE)
- ALUM. FRAMED CURTAIN WALL W/ CLEAR GLASS (DARK BRONZE)
- STACKED BOND BRICK (EBONY, SMOOTH)

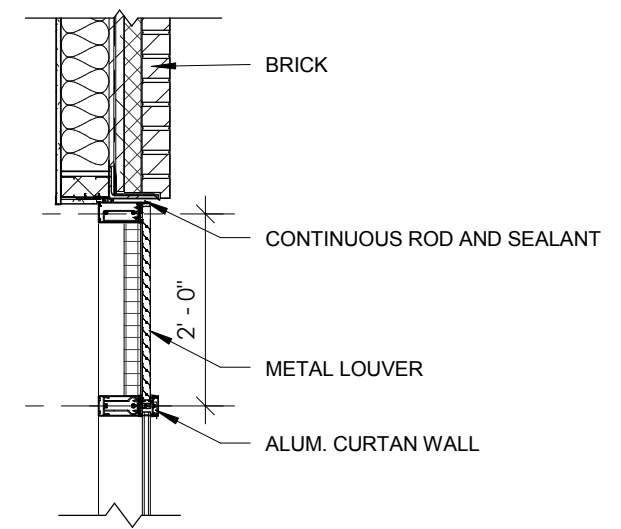
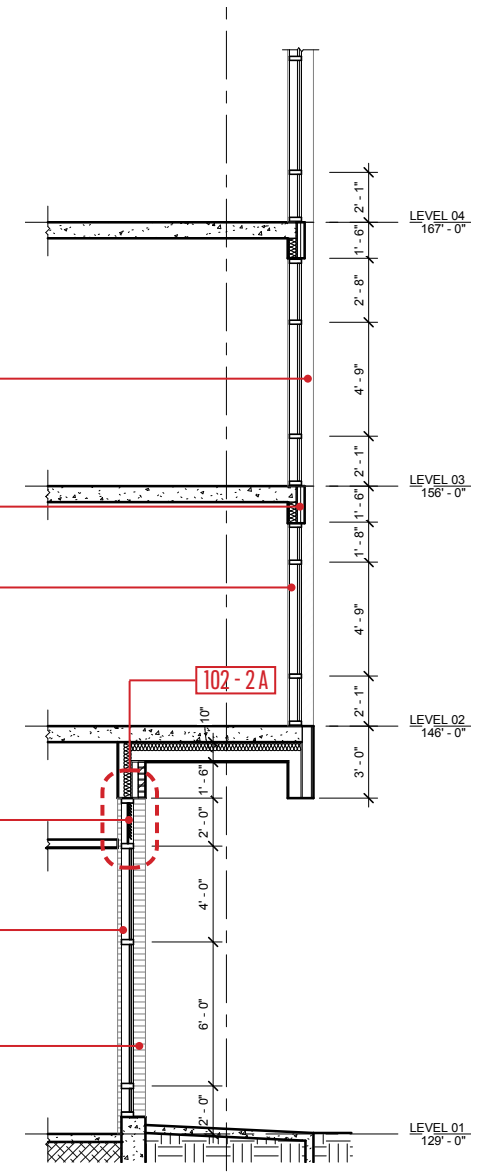

A. LOUVERS @ CURTAIN WALL CONNECT TO BRICK WALL

1/2" = 1'-0"



CURTAIN WALL WITH METAL LOUVER ON TOP



IMAGE OF PASS-THROUGH LOBBY @ ENTRANCE

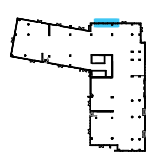

NORTHEAST PODIUM _ DETAIL: 102 - 2





- ALUM. FRAMED CURTAIN WALL W/
CLEAR GLASS (DARK BRONZE)
- METAL LOUVER (DARK BRONZE)
- GFRC (BEIGE, BRUSHED)
- INSULATED SPANDREL GLASS
(LIGHT GREY)
- METAL LOUVER (DARK BRONZE)
- STEEL & GLASS CANOPY (DARK BRONZE)
- ALUM. FRAMED CURTAIN WALL W/
CLEAR GLASS (DARK BRONZE)
- ALUM. FRAMED GLASS DOOR W/
CLEAR GLASS (DARK BRONZE)
- STACKED BOND BRICK
(EBONY, SMOOTH)

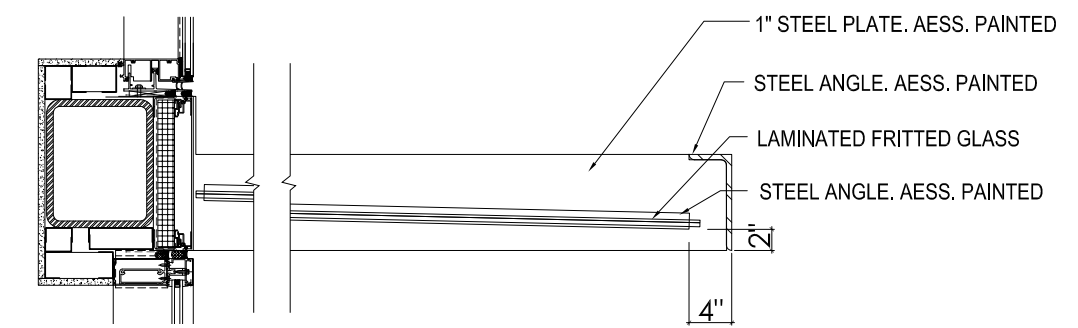
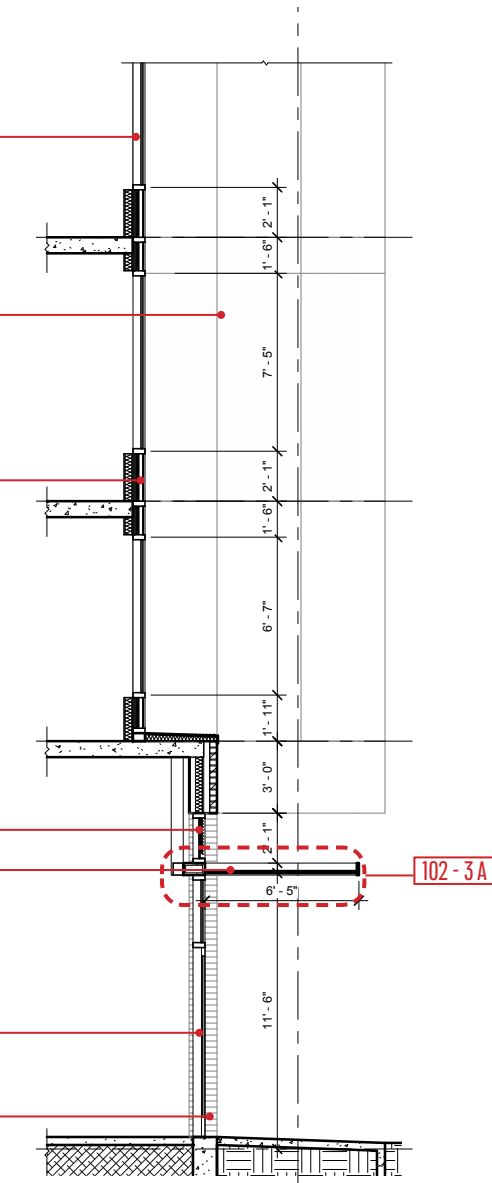

A. TYPICAL RETAIL CANOPY SECTION DETAIL
1" = 1'-0"

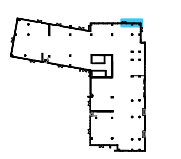

NORTHEAST RETAIL _ DETAIL: 102 - 3



ALUM. PUNCH WINDOW W/ CLEAR GLASS (DARK BRONZE)

METAL LOUVER (DARK BRONZE)

GFRC (BEIGE, BRUSHED)

STACKED BOND BRICK (EBONY, SMOOTH)

METAL LOUVER (DARK BRONZE)

STEEL & GLASS CANOPY (DARK BRONZE)

ALUM. FRAMED CURTAIN WALL W/ CLEAR GLASS (DARK BRONZE)

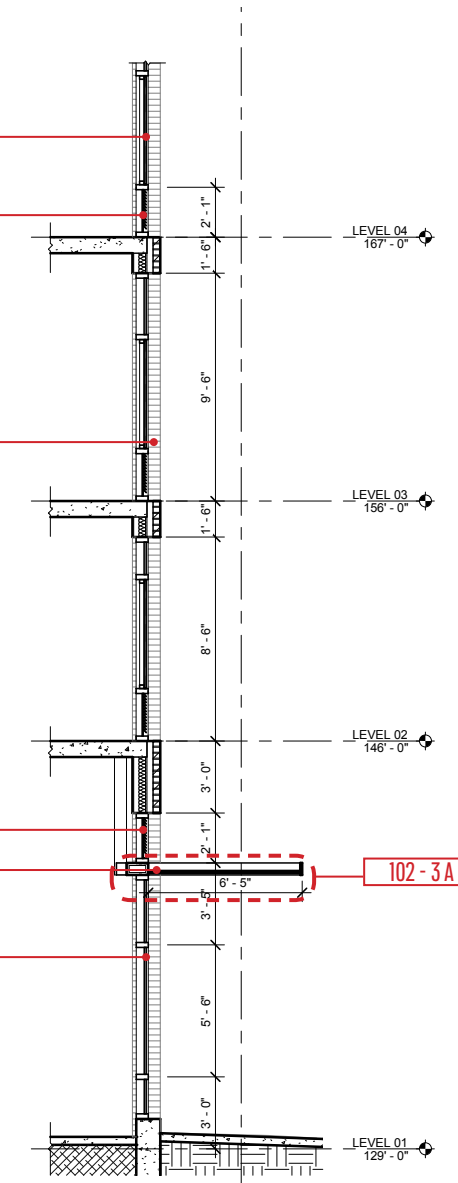
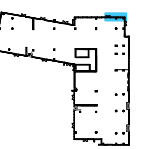
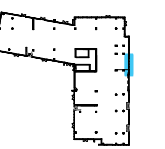
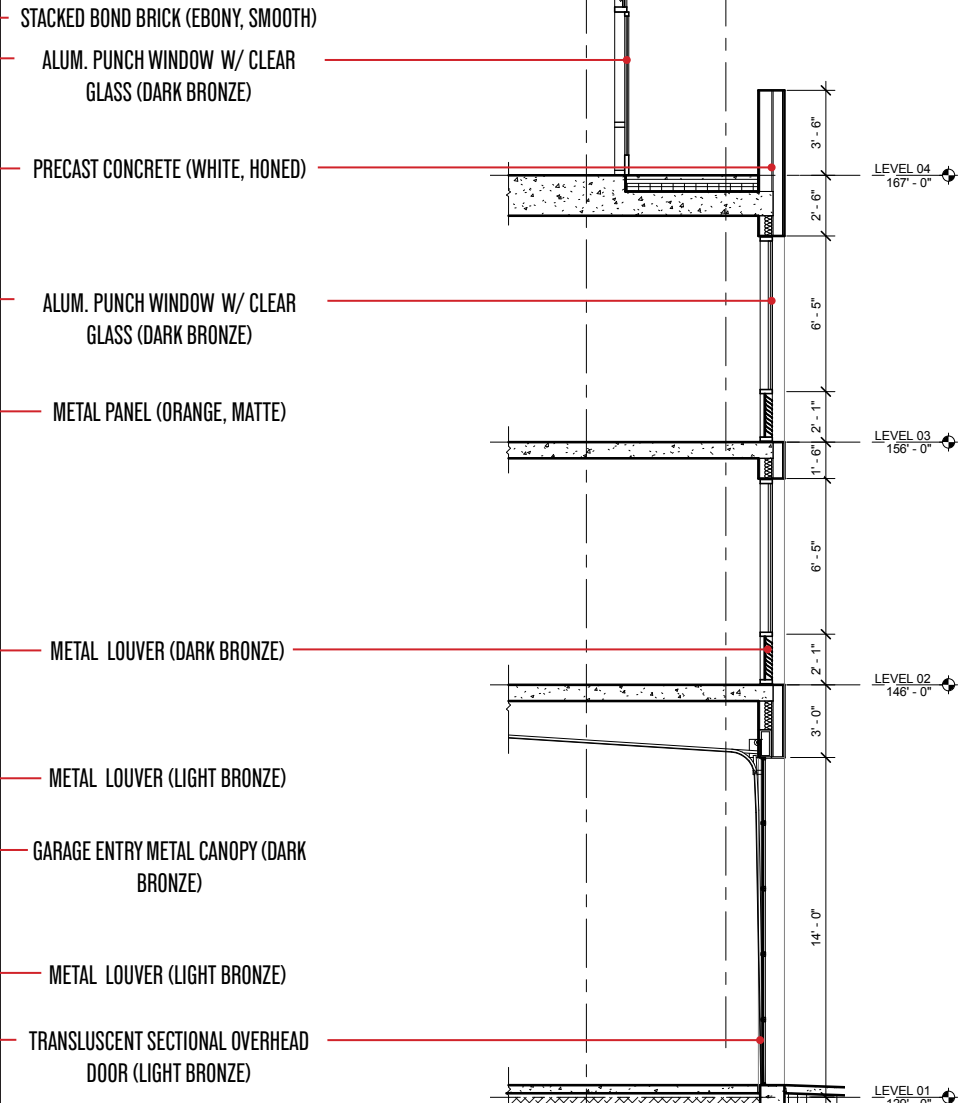

IMAGE OF NORTHEAST CORNER



NORTHEAST RETAIL _ DETAIL: 102 - 4



NORTHEAST LOADING _ DETAIL: 102 - 5

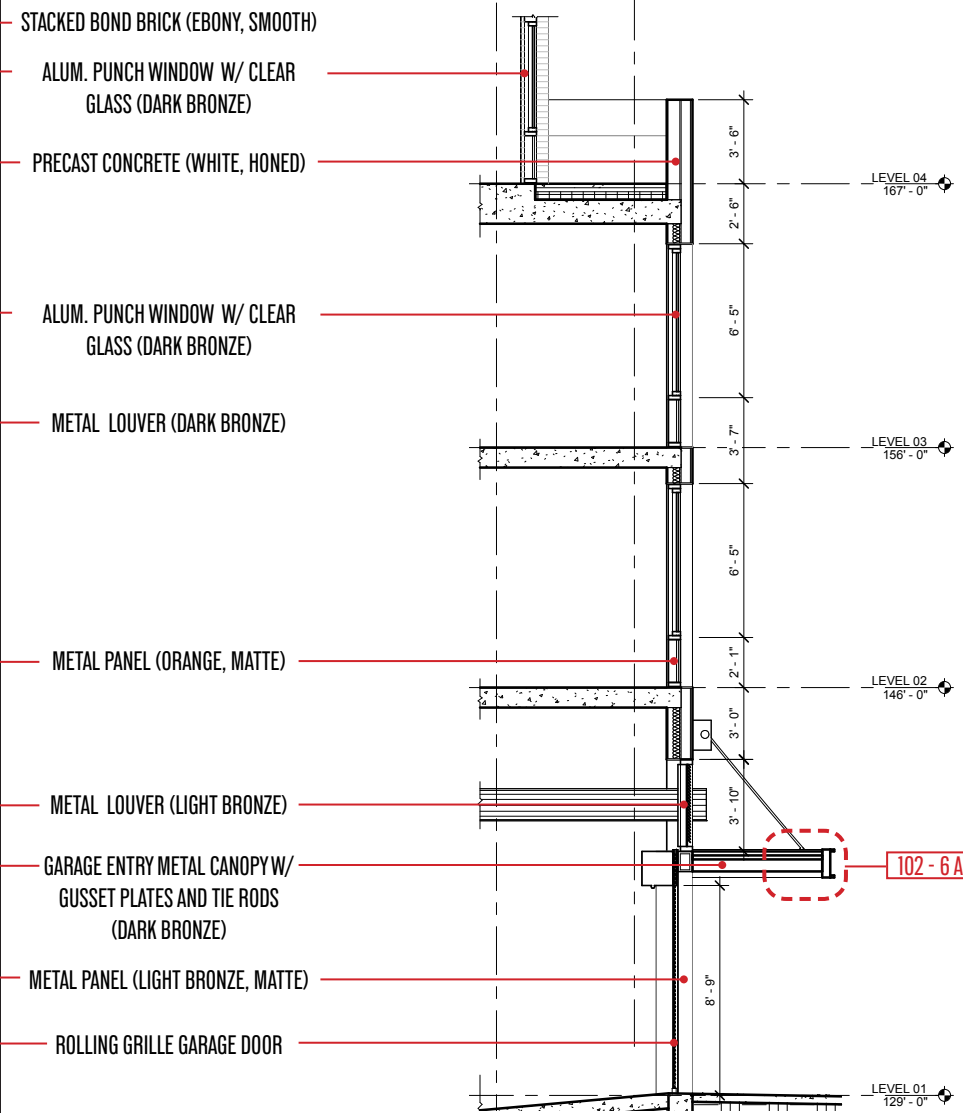

- STACKED BOND BRICK (EBONY, SMOOTH)
- ALUM. PUNCH WINDOW W/ CLEAR GLASS (DARK BRONZE)
- PRECAST CONCRETE (WHITE, HONED)
- ALUM. PUNCH WINDOW W/ CLEAR GLASS (DARK BRONZE)
- METAL LOUVER (DARK BRONZE)
- METAL PANEL (ORANGE, MATTE)
- METAL LOUVER (LIGHT BRONZE)
- GARAGE ENTRY METAL CANOPY W/ GUSSET PLATES AND TIE RODS (DARK BRONZE)
- METAL PANEL (LIGHT BRONZE, MATTE)
- ROLLING GRILLE GARAGE DOOR

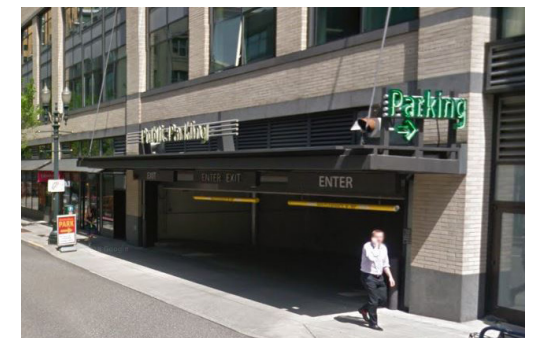

GARAGE ENTRY METAL CANOPY



GRILLE GARAGE DOOR

(NOTE: ROLLING GRILLE GARAGE DOOR LOCATED 1'-0" AWAY FROM PROPERTY LINE, AND DESIGN EXCEPTION PENDING)

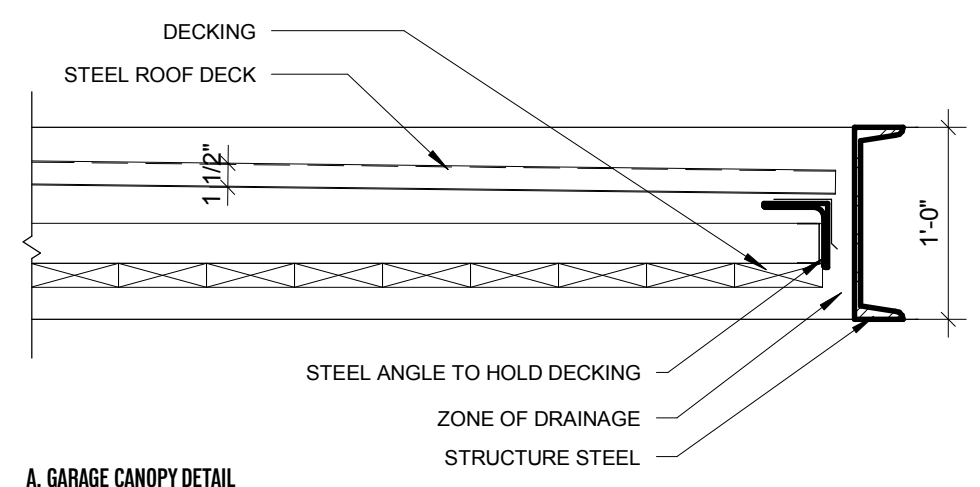

A. GARAGE CANOPY DETAIL

1" = 1'-0"

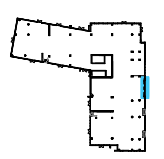

EAST GARAGE _ DETAIL: 102 - 6



- STACKED BOND BRICK (EBONY, SMOOTH)
- ALUM. PUNCH WINDOW W/ CLEAR GLASS (DARK BRONZE)
- PRECAST CONCRETE (WHITE, HONED)
- ALUM. PUNCH WINDOW W/ CLEAR GLASS (DARK BRONZE)
- METAL LOUVER (DARK BRONZE)
- METAL PANEL (ORANGE, MATTE)
- METAL LOUVER (DARK BRONZE)
- STEEL & GLASS CANOPY (DARK BRONZE)
- ALUM. FRAMED CURTAIN WALL W/ CLEAR GLASS (DARK BRONZE)
- ALUM. FRAMED GLASS DOOR W/ CLEAR GLASS (DARK BRONZE)

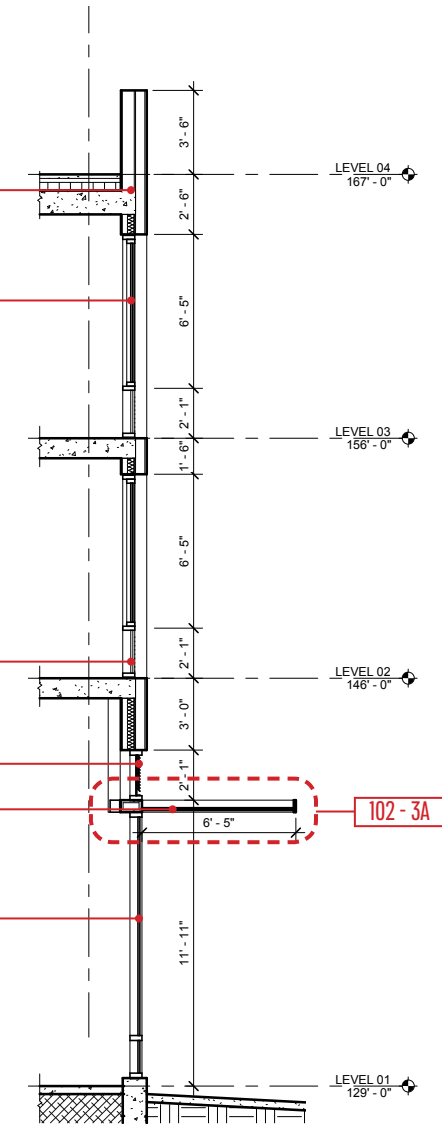

ALUM. FRAMED GLASS DOOR W/ CLEAR GLASS



IMAGE OF RETAIL @ SOUTHEAST CORNER

RETAIL

7' - 8'¹/₂" 24' - 5" 7' - 7'¹/₂" 16' - 2"

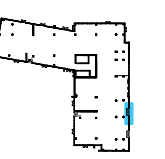

SOUTHEAST RETAIL _ DETAIL: 102 - 7



- STACKED BOND BRICK (EBONY, SMOOTH)
- ALUM. PUNCH WINDOW W/ CLEAR GLASS (DARK BRONZE)
- METAL LOUVER (DARK BRONZE)
- PRECAST CONCRETE (WHITE, HONED)
- ALUM. PUNCH WINDOW W/ CLEAR GLASS (DARK BRONZE)
- METAL PANEL (ORANGE, MATTE)
- GLASS GUARDRAIL W/ TOP RAIL
- METAL LOUVER (DARK BRONZE)
- ALUM. FRAMED CURTAIN WALL W/ CLEAR GLASS (DARK BRONZE)

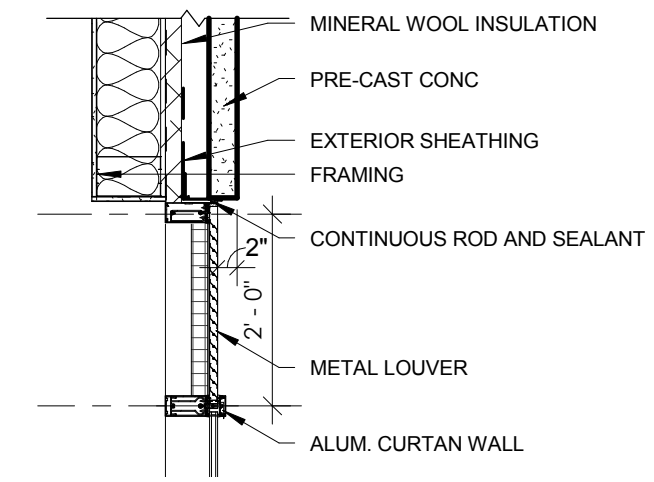
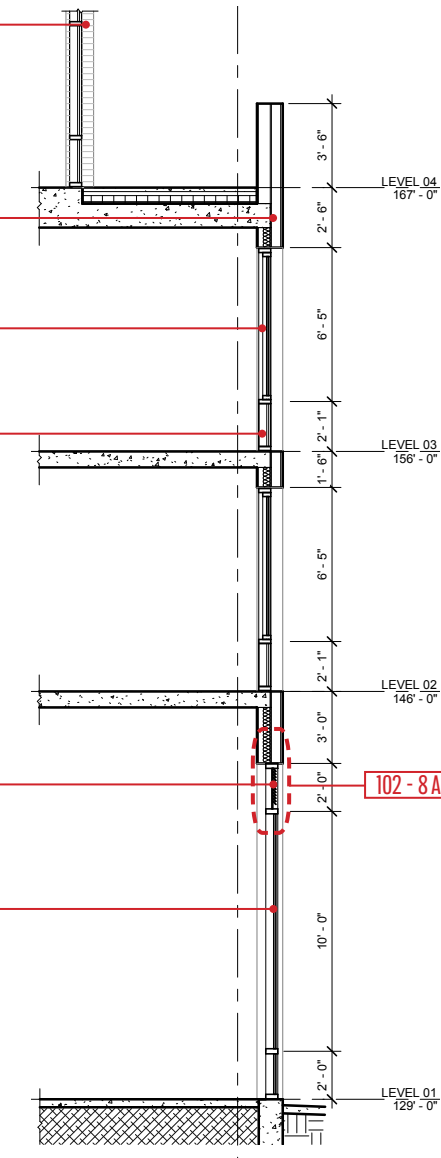

A. LOUVERS @ CURTAIN WALL CONNECT PRECAST WALL

1/2" = 1'-0"

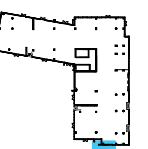

SOUTH PODIUM _ DETAIL: 102 - 8



- ALUM. PUNCH WINDOW W/ CLEAR GLASS (DARK BRONZE)
- METAL LOUVER (DARK BRONZE)
- GLASS GUARDRAIL W/ TOP RAIL
- STACKED BOND BRICK (EBONY, SMOOTH)
- ALUM. FRAMED CURTAIN WALL W/ CLEAR GLASS (DARK BRONZE)

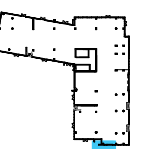
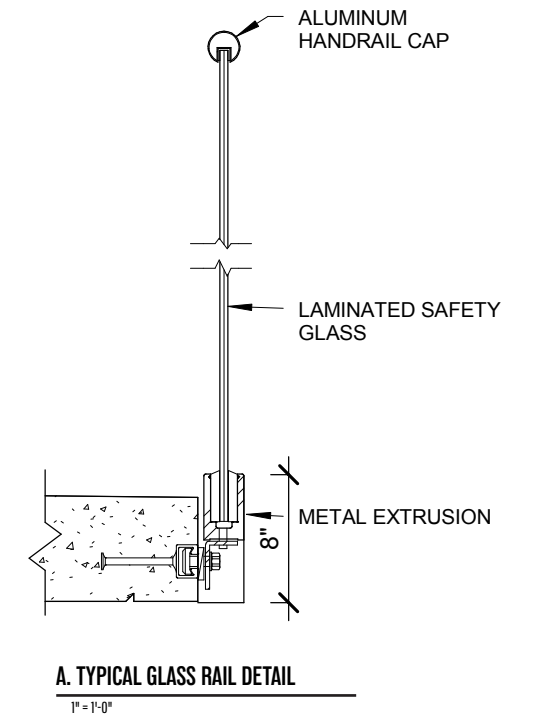
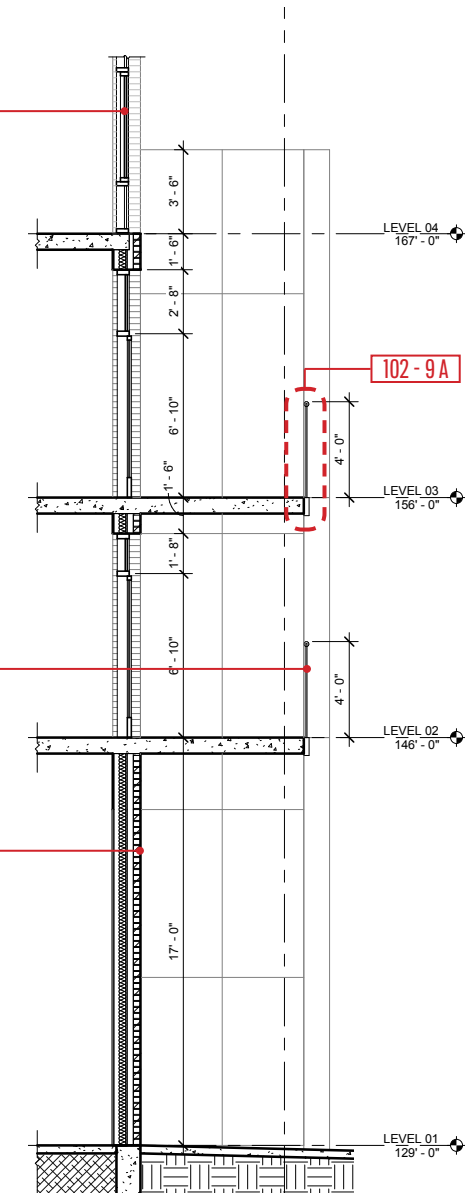

SOUTH PODIUM _ DETAIL: 102 - 9



- ALUM. PUNCH WINDOW W/ CLEAR GLASS (DARK BRONZE)
- METAL LOUVER (DARK BRONZE)
- PRECAST CONCRETE (WHITE, HONED)
- GLASS GUARDRAIL W/ TOP RAIL
- STACKED BOND BRICK (EBONY, SMOOTH)
- ALUM. PUNCH WINDOW W/ CLEAR GLASS (DARK BRONZE)
- METAL PANEL (ORANGE, MATTE)
- METAL LOUVER (DARK BRONZE)
- STEEL & GLASS CANOPY (DARK BRONZE)
- ALUM. FRAMED CURTAIN WALL W/ CLEAR GLASS (DARK BRONZE)
- METAL PANEL (DARK BRONZE, MATTE)
- METAL PANEL (WHITE, MATTE)

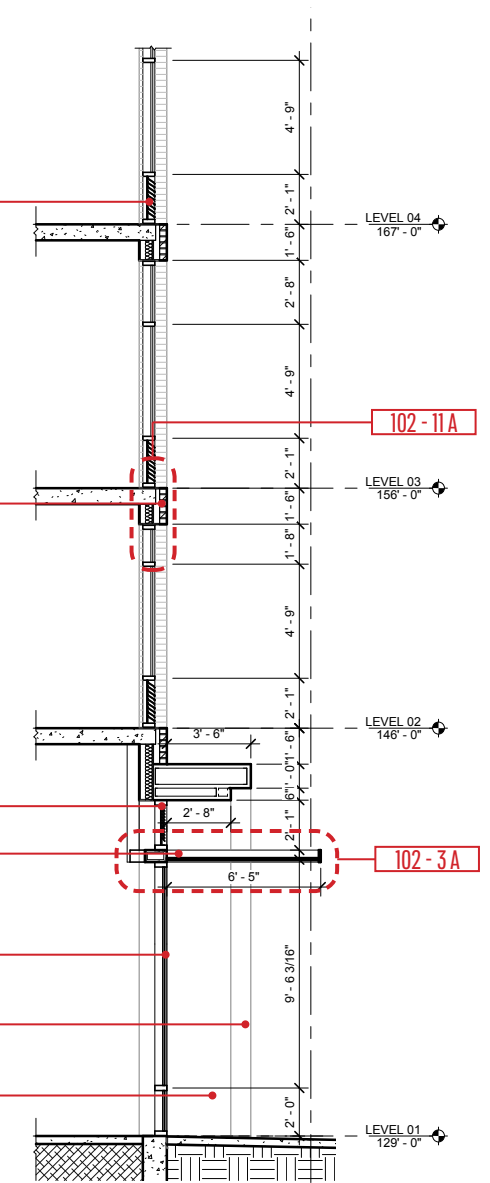

PRECAST CONCRETE (HONED)



IMAGE OF SOUTHWEST CONNER

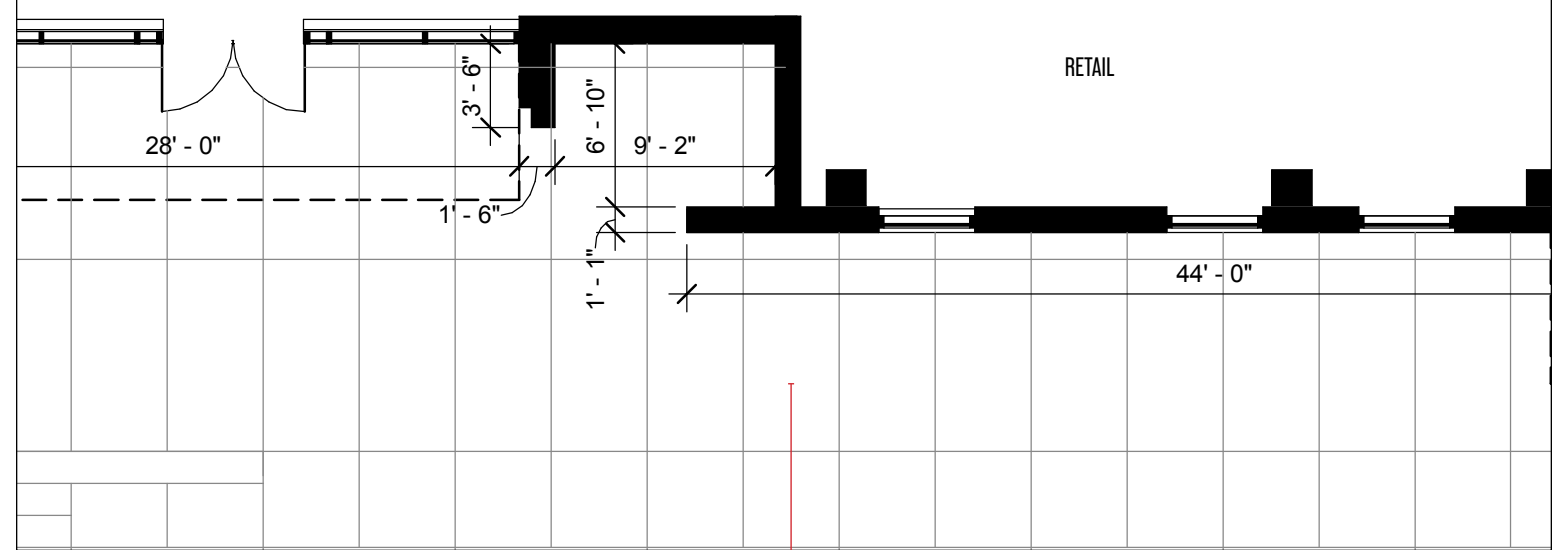

SOUTHWEST ENTRY _ DETAIL: 102 - 10



- ALUM. PUNCH WINDOW W/ CLEAR GLASS (DARK BRONZE)
- METAL LOUVER (DARK BRONZE)
- GLASS GUARDRAIL W/ TOP RAIL
- STACKED BOND BRICK (EBONY, SMOOTH)
- METAL LOUVER (DARK BRONZE)
- STEEL & GLASS CANOPY (DARK BRONZE)
- ALUM. FRAMED CURTAIN WALL W/ CLEAR GLASS (DARK BRONZE)

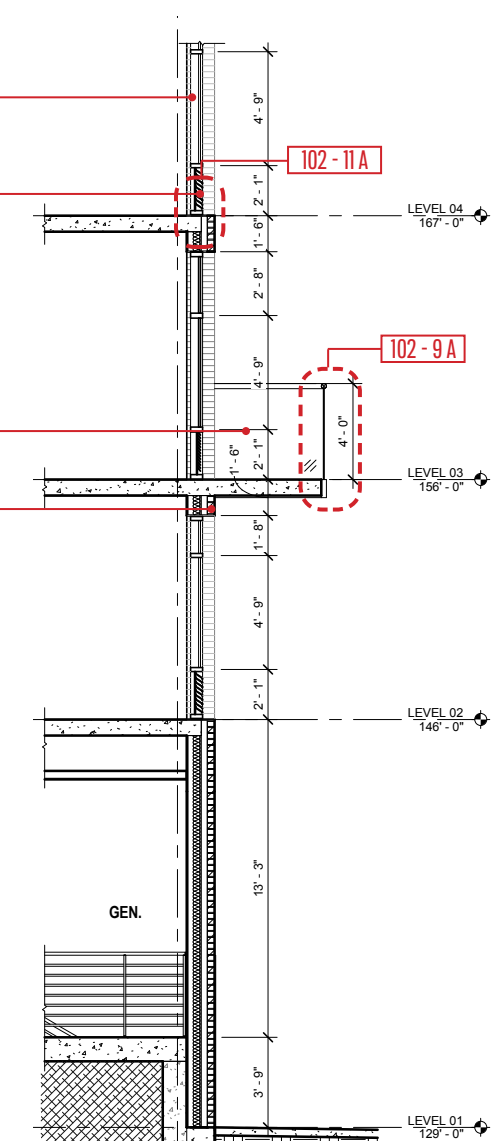

ALUM. PUNCH WINDOW WITH LOUVER



IMAGE OF RETAIL @ SOUTHWEST CORNER

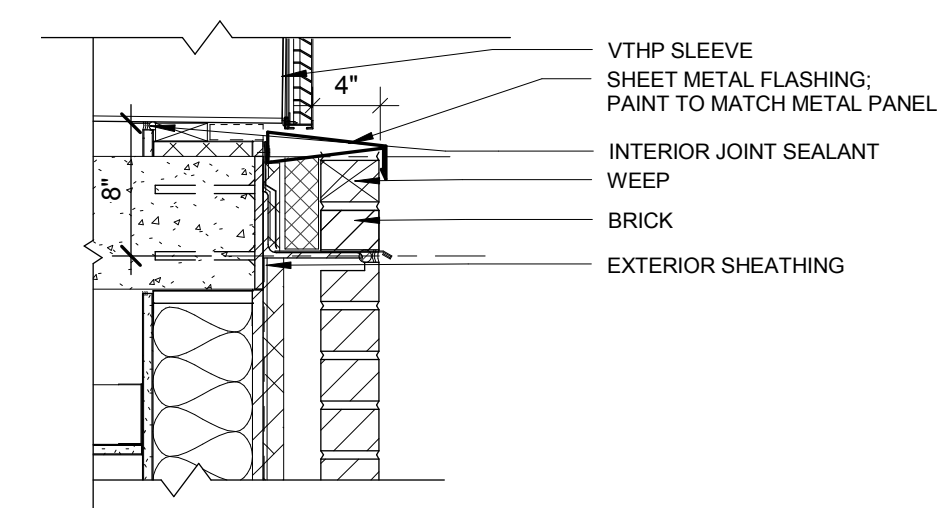

A. LOUVERS ABOVE BRICK WALL DETAIL

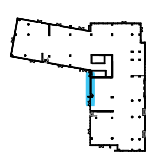

WEST ENTRY _ DETAIL: 102 - 11



ALUM. FRAMED CURTAIN WALL W/
CLEAR GLASS (DARK BRONZE)

METAL LOUVER (DARK BRONZE)

GFRC (BEIGE, BRUSHED)

GLASS GUARDRAIL W/ TOP RAIL

STACKED BOND BRICK (EBONY, SMOOTH)

METAL PANEL (DARK BRONZE, MATTE)

METAL PANEL (WHITE, MATTE)

STEEL & GLASS CANOPY
(PAINTED WHITE)

ALUM. FRAMED CURTAIN WALL W/
CLEAR GLASS (DARK BRONZE)

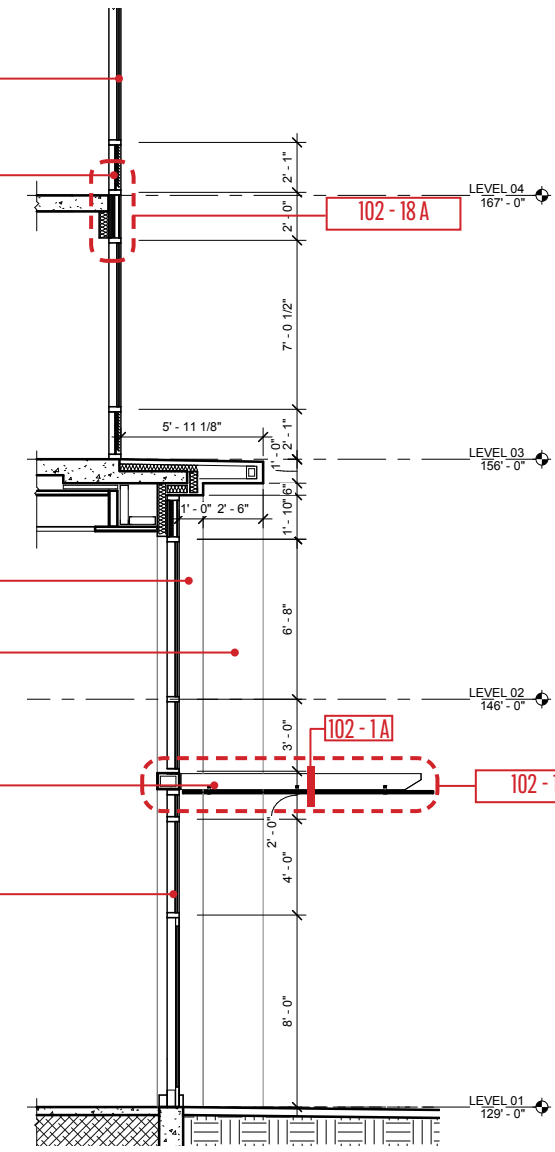

METAL WRAP AT ENTRY



IMAGE OF ENTRY AT COURTYARD

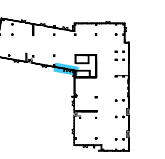
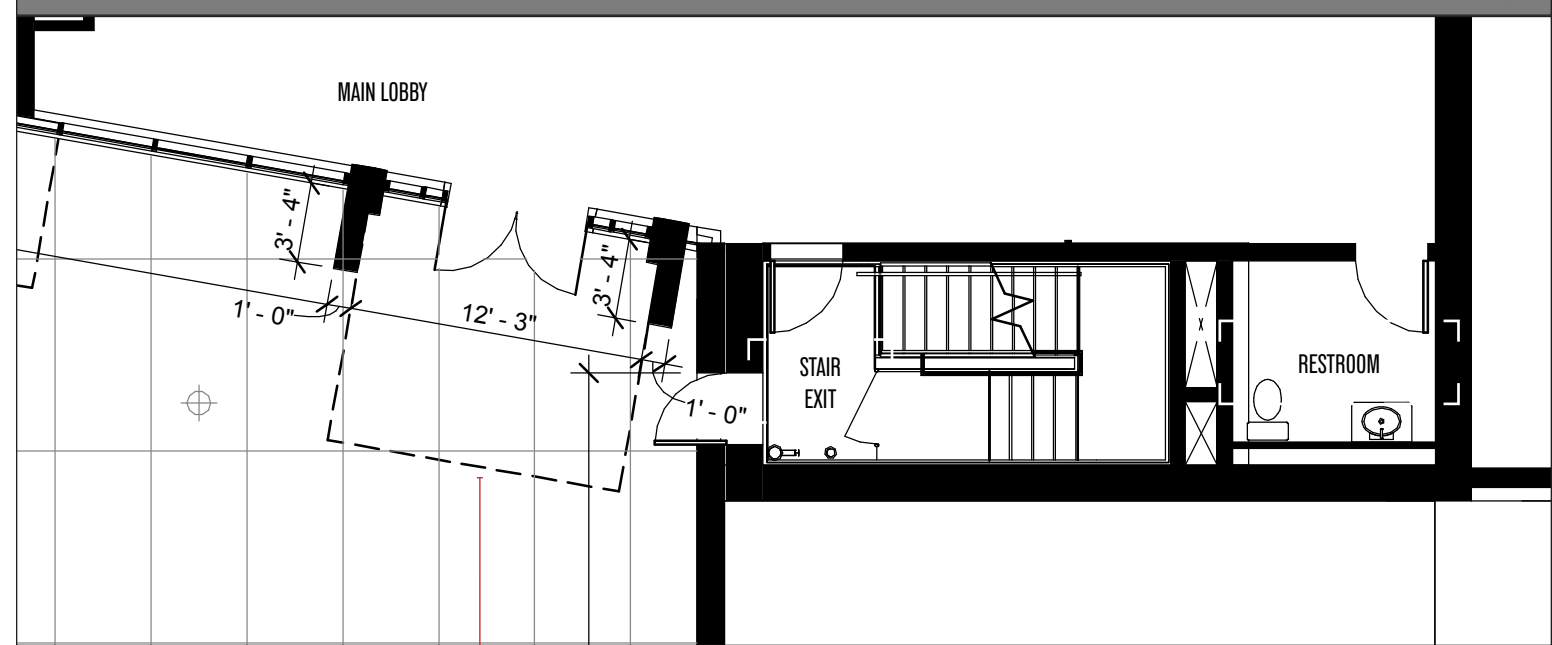

COURTYARD CORNER ENTRY _ DETAIL: 102 - 12



- ALUM. PUNCH WINDOW W/ CLEAR GLASS (DARK BRONZE)
- METAL PANEL (DARK BRONZE, MATTE)
- METAL PANEL (WHITE, MATTE)
- METAL LOUVER (DARK BRONZE)
- GFRC (BEIGE, BRUSHED)
- STEEL & GLASS CANOPY (DARK BRONZE)
- ALUM. FRAMED CURTAIN WALL W/ CLEAR GLASS (DARK BRONZE)

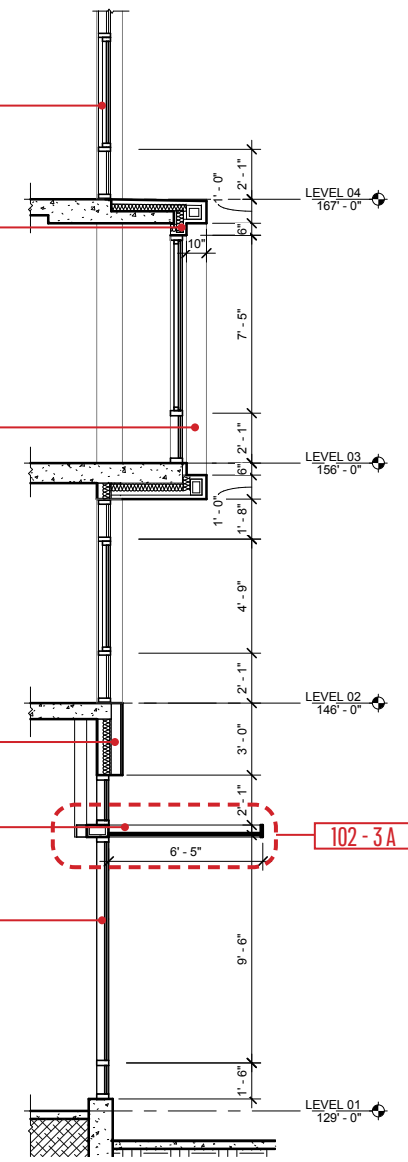

STEEL & GLASS RETAIL CANOPY



IMAGE OF PODIUM SOUTHWEST CORNER

SOUTHWEST CORNER RETAIL _ DETAIL: 102 - 13



METAL PANEL (DARK BRONZE, MATTE)

METAL PANEL (DARK BRONZE, MATTE)

METAL PANEL (WHITE, MATTE)

ALUM. PUNCH WINDOW W/ CLEAR GLASS (DARK BRONZE)

METAL LOUVER (DARK BRONZE)

GFRC (BEIGE, BRUSHED)

STEEL & GLASS CANOPY (DARK BRONZE)

ALUM. FRAMED CURTAIN WALL W/ CLEAR GLASS (DARK BRONZE)

ALUM. FRAMED GLASS DOOR W/ CLEAR GLASS (DARK BRONZE)

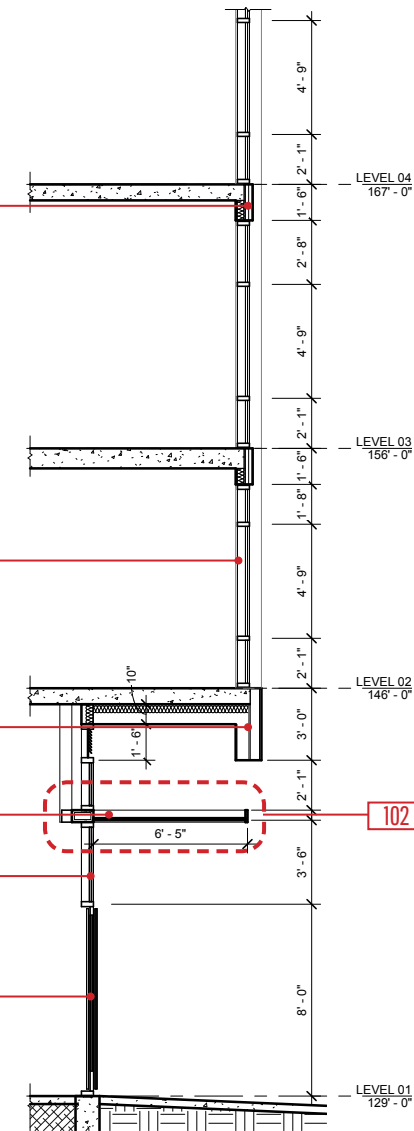

ALUM. PUNCH WINDOW WITH METAL PANEL



IMAGE OF PODIUM @ WEST

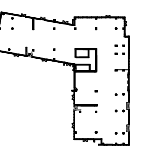
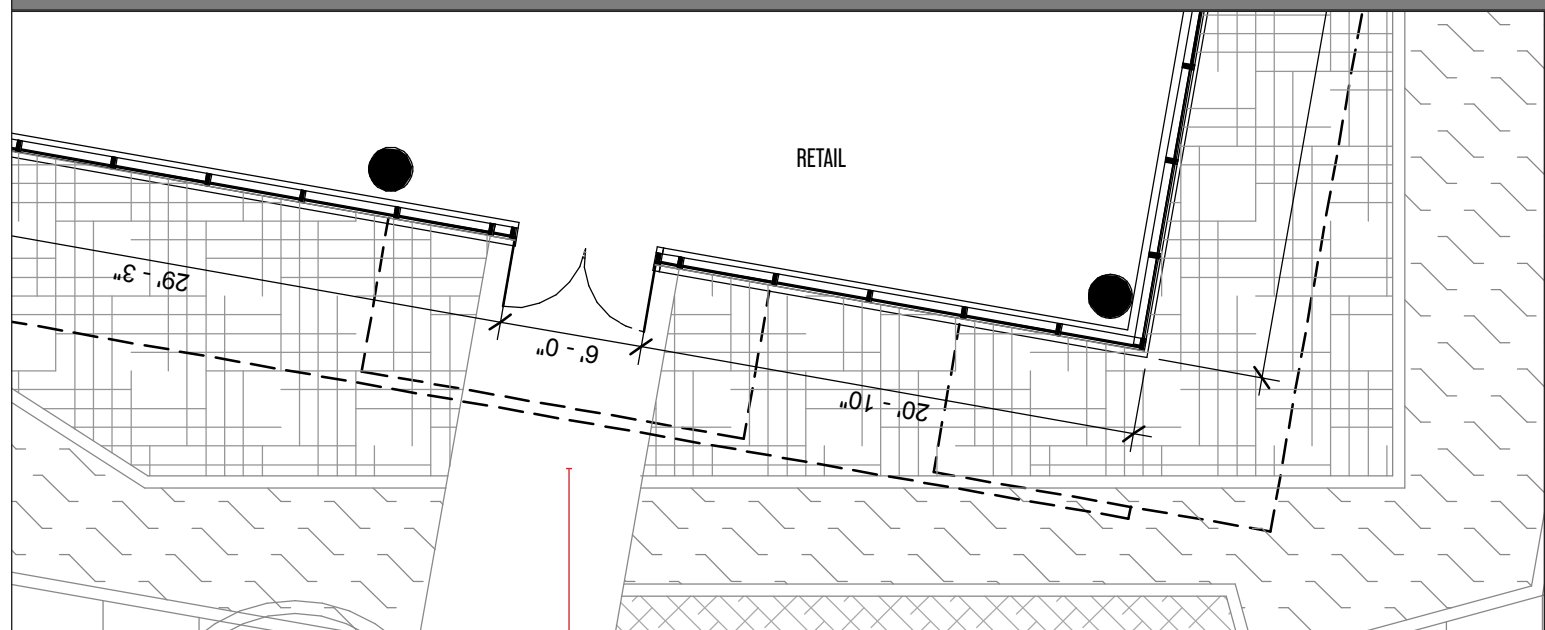

NORTHWEST CORNER RETAIL _ DETAIL: 102 - 14



- GFR (BEIGE, BRUSHED)
- ALUM. PUNCH WINDOW W/ CLEAR GLASS (DARK BRONZE)
- METAL LOUVER (DARK BRONZE)
- GLASS GUARDRAIL W/ TOP RAIL
- METAL PANEL (DARK BRONZE, MATTE)
- PAINTED METAL FASCIA
- STEEL & GLASS CANOPY (DARK BRONZE)
- ALUM. FRAMED CURTAIN WALL W/ CLEAR GLASS (DARK BRONZE)
- ALUM. FRAMED GLASS DOOR W/ CLEAR GLASS (DARK BRONZE)

102 - 15 A

102 - 9 A

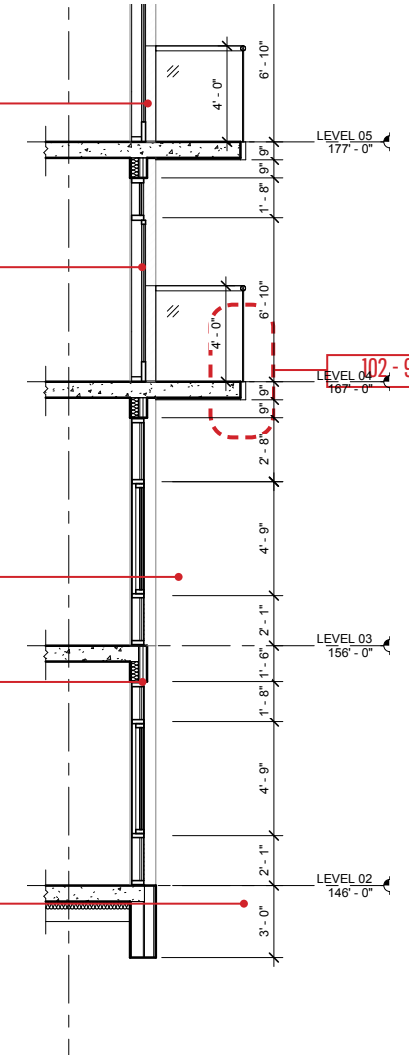
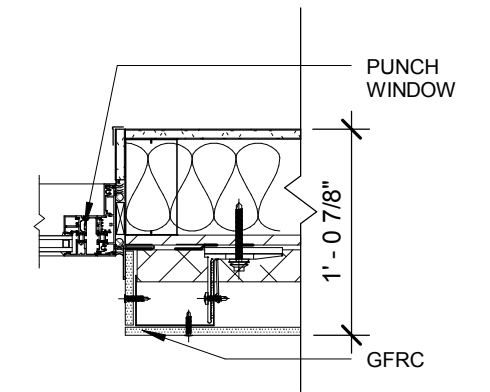
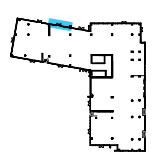

IMAGE OF BALCONIES @ PODIUM



A. TYPICAL WINDOW JAMB @ GFR DETAIL
1" = 1'-0"



NORTHWEST PODIUM _ DETAIL: 102 - 15



- STACKED BOND BRICK (EBONY, SMOOTH)
- METAL PANEL (DARK BRONZE, MATTE)
- METAL PANEL (WHITE, MATTE)
- METAL LOUVER (DARK BRONZE)
- INSULATED SPANDREL GLASS (LIGHT GREY)
- ALUM. PUNCH WINDOW W/ CLEAR GLASS (DARK BRONZE)
- GLASS GUARDRAIL W/ TOP RAIL
- GFRC (BEIGE, BRUSHED)

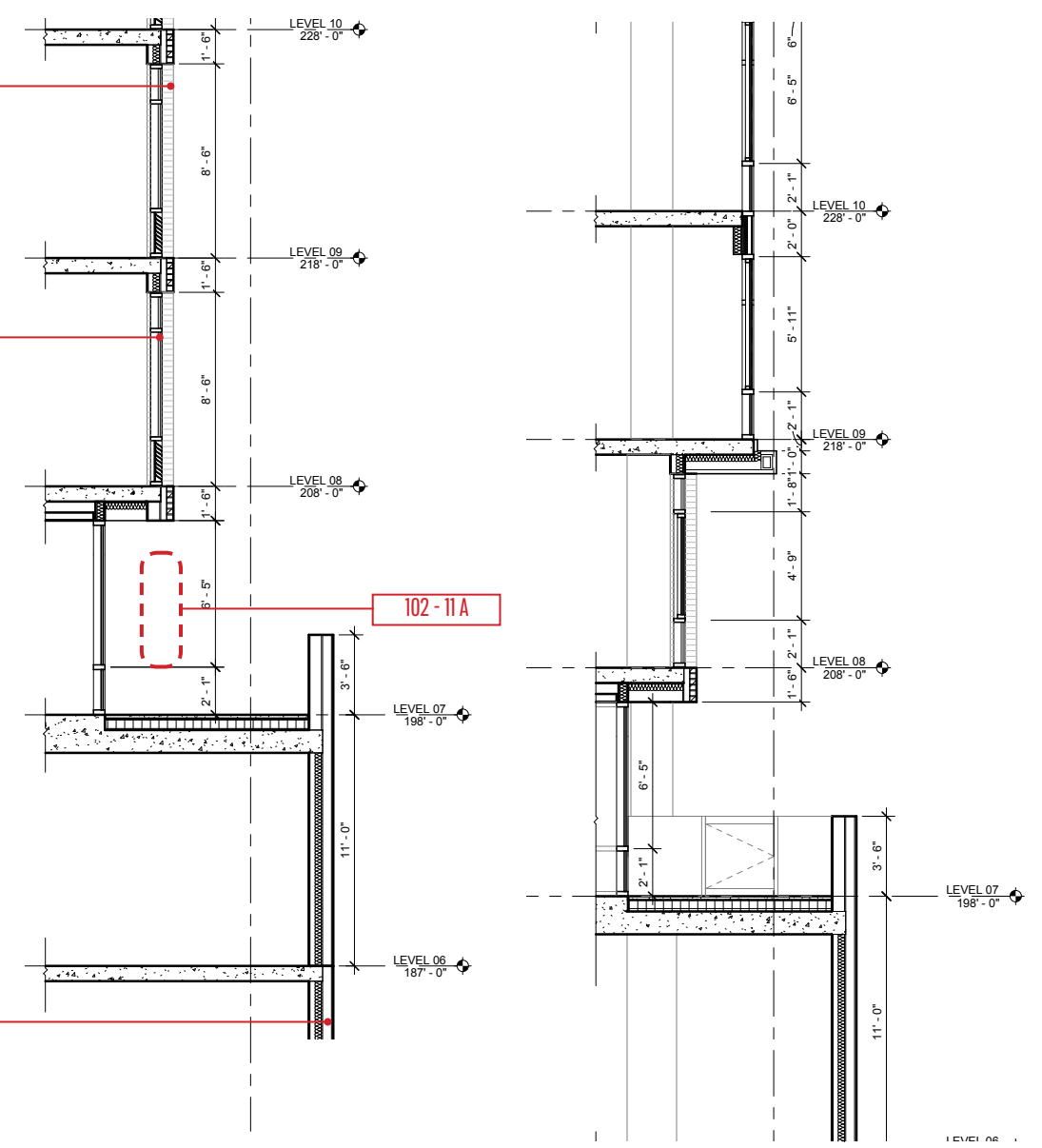

NORTHWEST TOWER _ DETAIL: 102 - 16

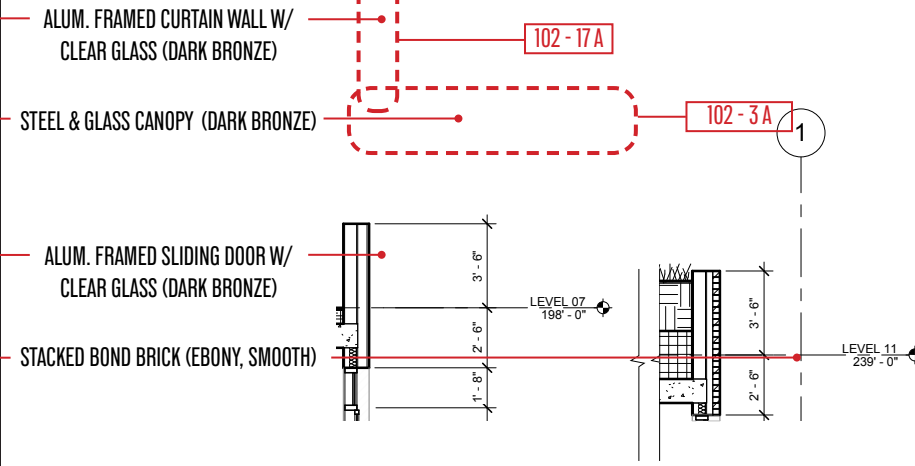

SLIDING DOOR

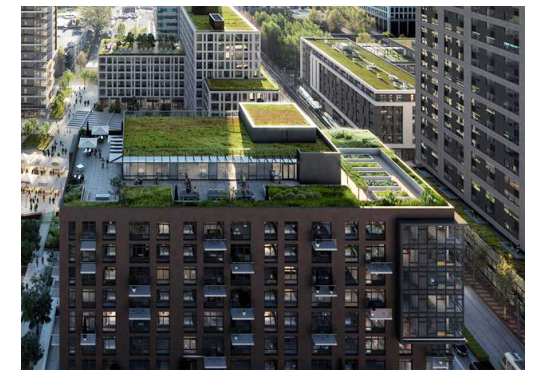
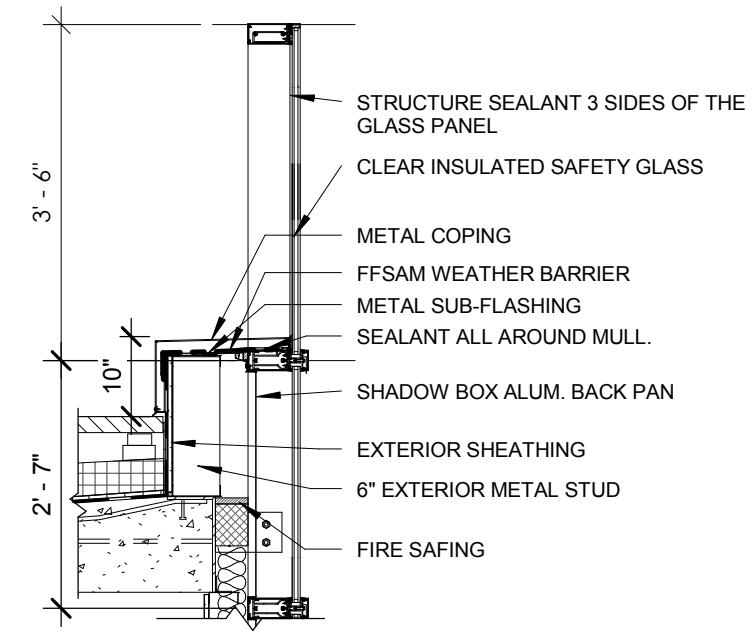

IMAGE OF EAST FACADE



A. ROOF CURTAIN WALL PARAPET DETAIL



EAST ROOF _ DETAIL: 102 - 17



STACKED BOND BRICK (EBONY, SMOOTH)

METAL PANEL (WHITE, MATTE)

ALUM. FRAMED CURTAIN WALL W/CLEAR GLASS (DARK BRONZE)

ALUM. FRAMED OPERABLE WINDOW W/CLEAR GLASS (DARK BRONZE)

INSULATED SPANDREL GLASS (LIGHT GREY)

METAL LOUVER (DARK BRONZE)

METAL PANEL (DARK BRONZE, MATTE)

GLASS GUARDRAIL W/ TOP RAIL

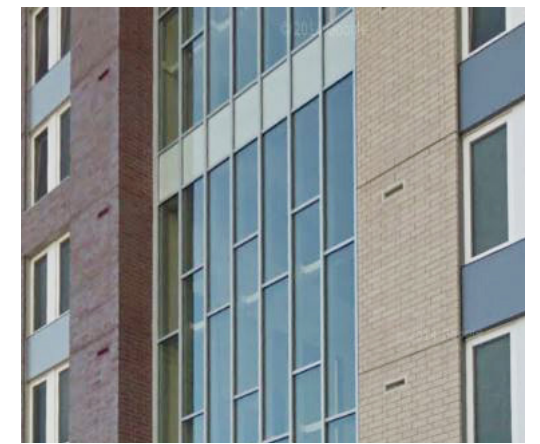
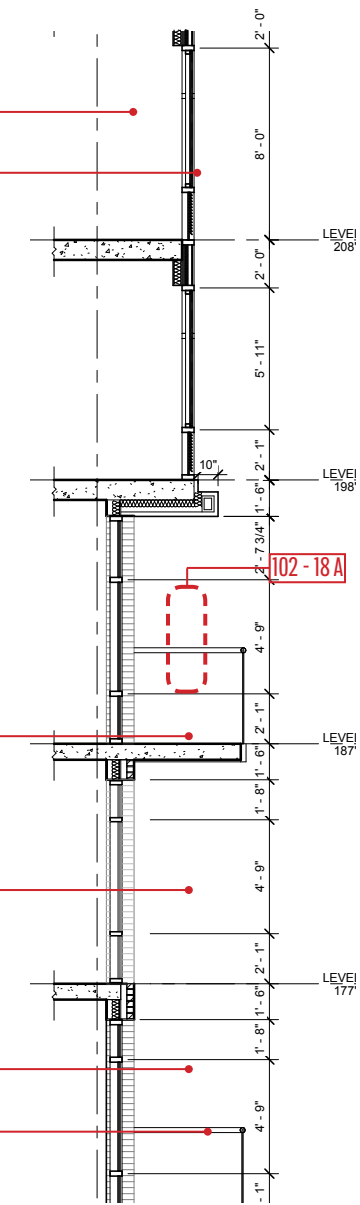

CURTAIN WALL

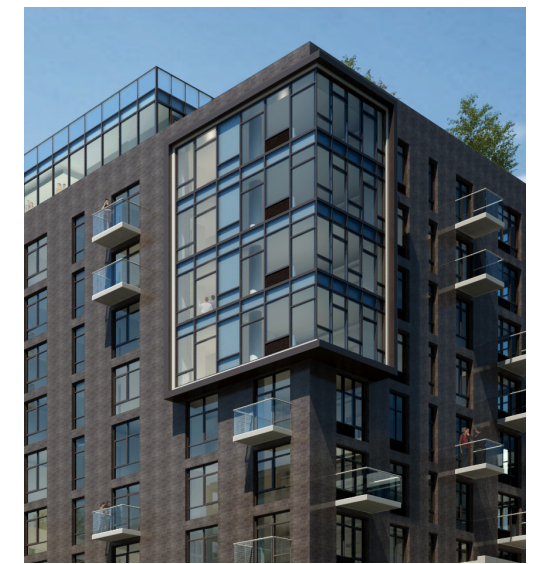
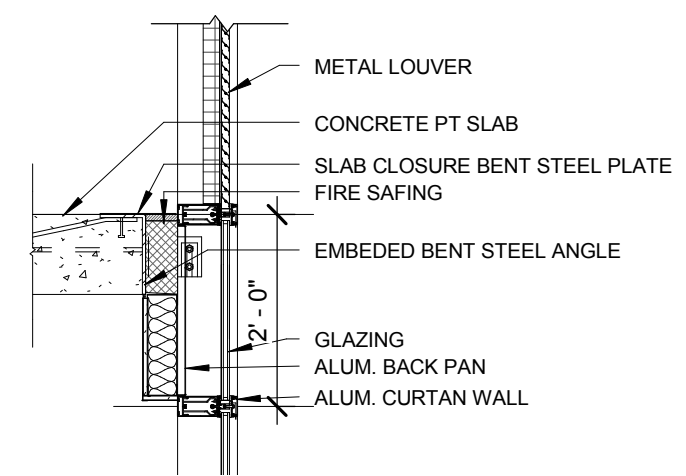

IMAGE OF SOUTHWEST CORNER CURTAIN WALL



A. LOUVER @ CURTAIN WALL ABOVE SPANDREL GLASS

1/2" = 1'-0"

SOUTHWEST CORNER TOWER _ DETAIL: 102 - 18





ALUM. FRAMED CURTAIN WALL W/
CLEAR GLASS (DARK BRONZE)

STACKED BOND BRICK (EBONY, SMOOTH)

ALUM. PUNCH WINDOW W/ CLEAR
GLASS (DARK BRONZE)

METAL LOUVER (DARK BRONZE)

GLASS GUARDRAIL W/ TOP RAIL

PAINTED METAL FASCIA

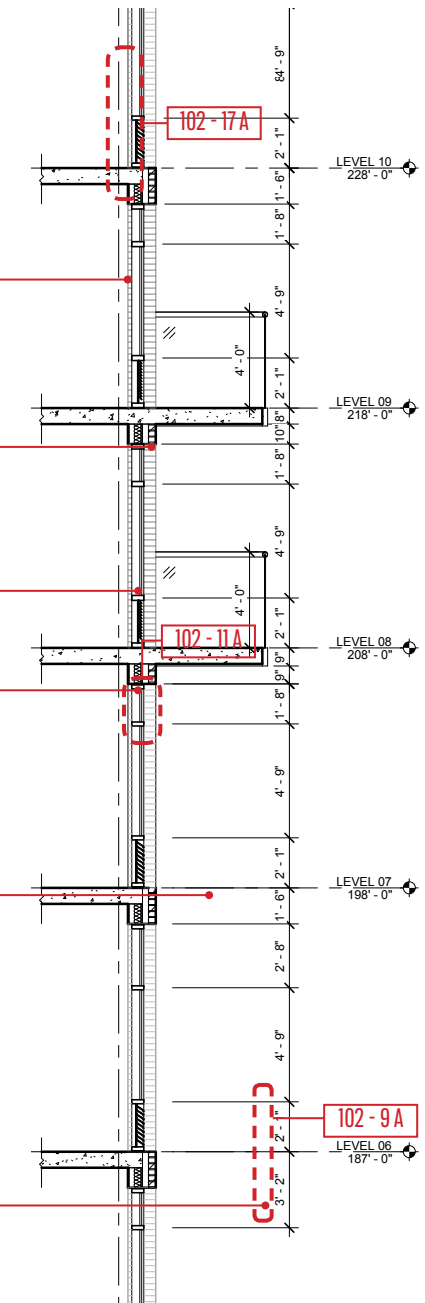

GLASS GUARDRAIL W/ TOP RAIL



PERSPECTIVE OF SOUTHWEST

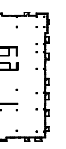

WEST ROOF _ DETAIL: 102 - 19



STACKED BOND BRICK (EBONY, SMOOTH)

ALUM. PUNCH WINDOW W/ CLEAR GLASS (DARK BRONZE)

PAINTED FASCIA

GLASS GUARDRAIL W/ TOP RAIL

STEEL & GLASS CANOPY (DARK BRONZE)

GFRC (BEIGE, BRUSHED)

GLASS GUARDRAIL W/ TOP RAIL

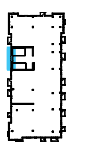
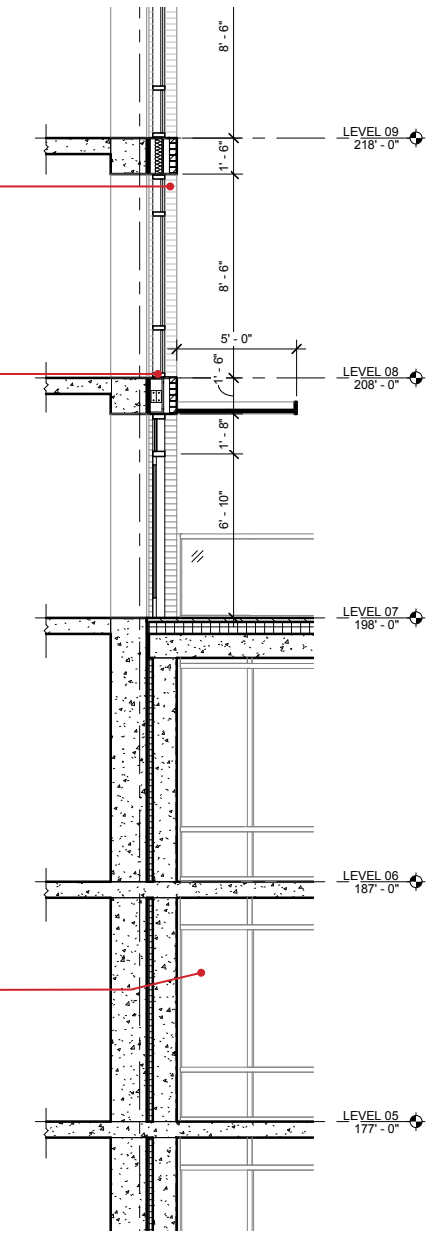

WEST TOWER _ DETAIL: 102 - 20



STACKED BOND BRICK (EBONY, SMOOTH)

ALUM. PUNCH WINDOW (DARK BRONZE) W/
CLEAR GLASS

METAL LOUVER (DARK BRONZE)

ALUM. FRAMED CURTAIN WALL W/ CLEAR GLASS

INSULATED SPANDREL GLASS

GFRC (BEIGE, BRUSHED)

METAL PANEL (DARK BRONZE, MATTE)

GLASS GUARDRAIL W/ TOP RAIL

PRECAST CONCRETE (WHITE, HONED)

ALUM. FRAMED CURTAIN WALL W/ CLEAR GLASS



REPRESENTATIVE IMAGE OF ALUM. PUNCH WINDOWS

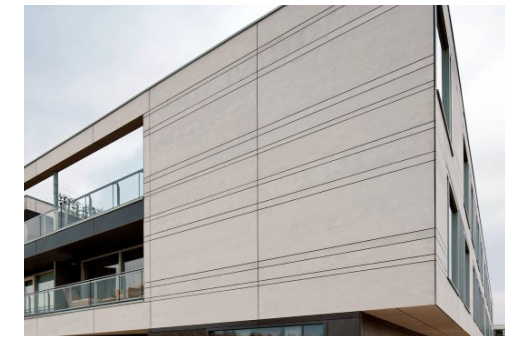

REPRESENTATIVE IMAGE OF GFRC PANELS



REPRESENTATIVE IMAGE OF BRICK (EBONY, SMOOTH)



REPRESENTATIVE IMAGE OF GLASS GUARDRAIL BALCONY



REPRESENTATIVE IMAGE OF PRECAST CONCRETE WALL



REPRESENTATIVE IMAGE OF ECO ROOF



REPRESENTATIVE IMAGE OF CURTAIN WALL BUMP-OUT CORNER



REPRESENTATIVE IMAGE OF STEEL GLASS CANOPY

EXTERIOR FEATURE



.040 ALUMINUM HONEYCOMB CORE PANEL (LIGHT BRONZE, MATTE)



GFRC (EXPOSED FASTENERS, BEIGE, BRUSHED)

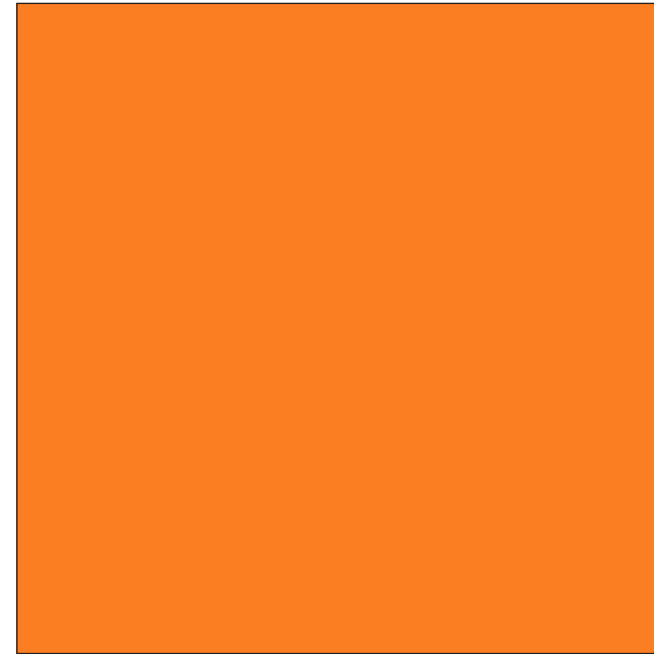

.040 ALUMINUM HONEYCOMB CORE PANEL (ORANGE, MATTE)



.040 ALUMINUM HONEYCOMB CORE PANEL (DARK BRONZE, MATTE)

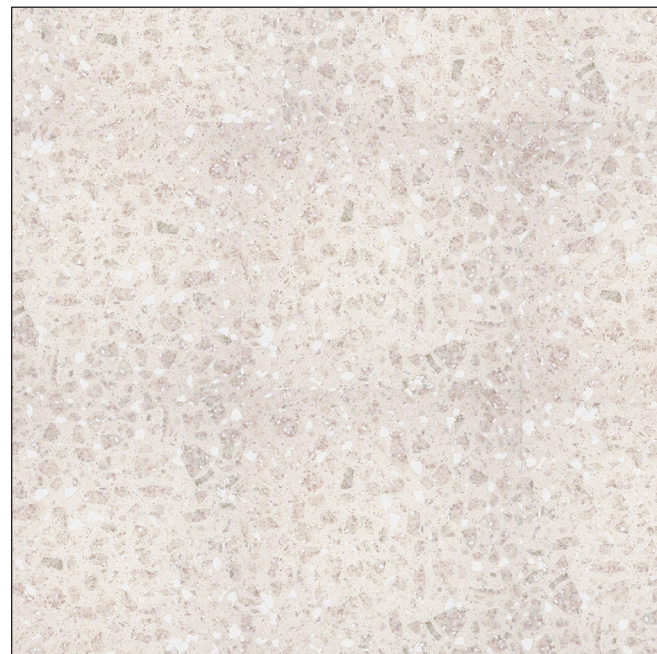

PRECAST CONCRETE (WHITE, HONED)



REPRESENTATIVE IMAGE OF BRICK (EBONY, SMOOTH)

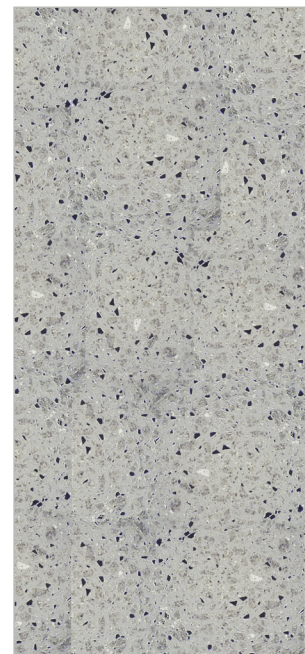

CONCRETE BLEND (PAVERS)

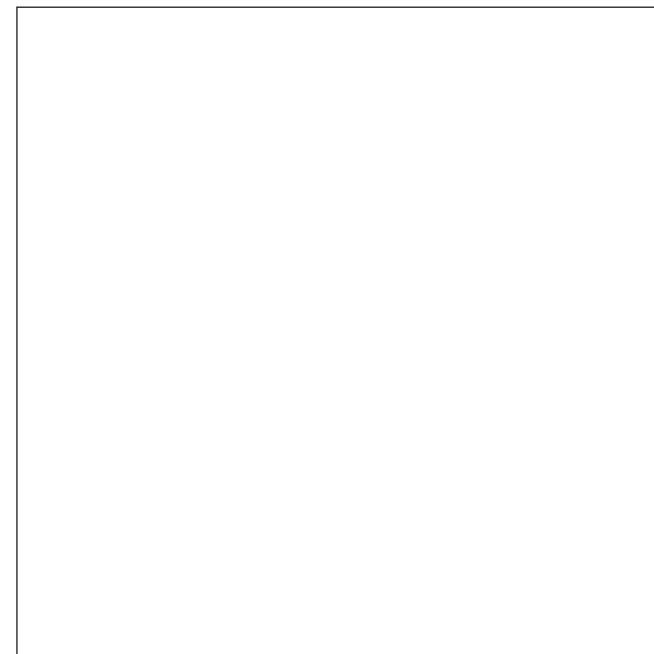

METAL PANEL (WHITE, MATTE)



6" X 8' WOOD PLANKS (IPE)

MATERIAL PALETTE

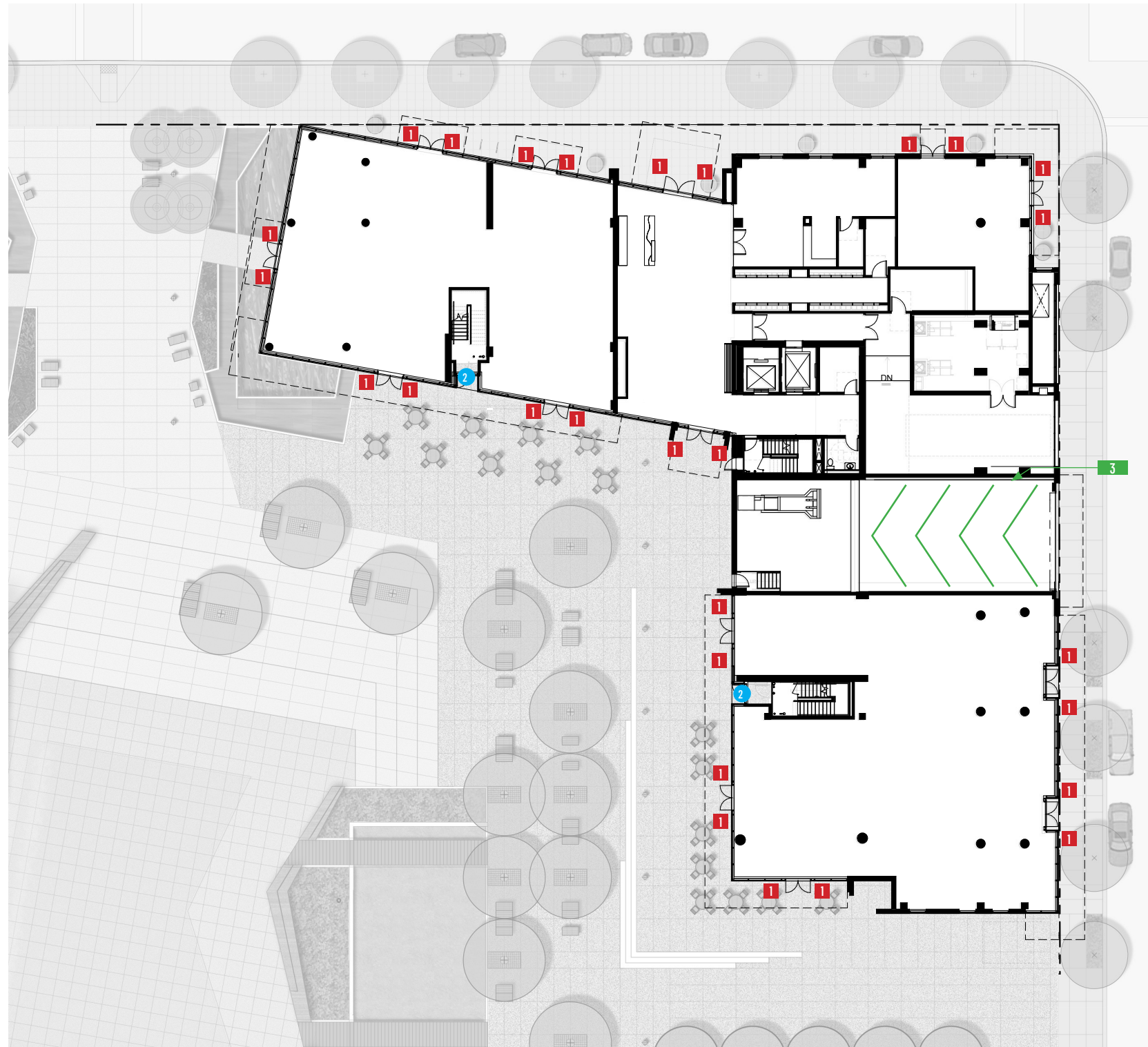

1 **4' LINEAR LED**
FINISH: TIGER DRYLAC CERTIFIED
POLYESTER POWDER COAT FINISH
COLOR: 3500K
MOUNT: SURFACE

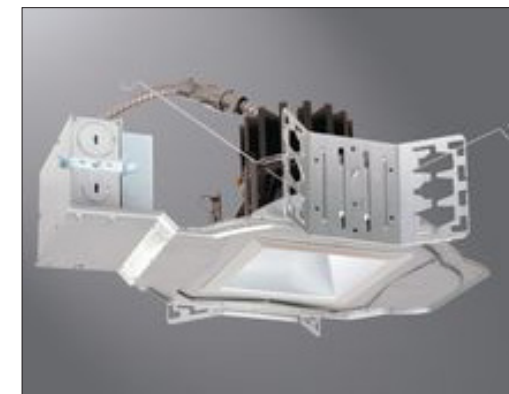

2 **4" SQUARE DOWNLIGHT**
FINISH: CORROSION RESIST. ALUMN. PTD.
COLOR: 3500K
MOUNT: RECESSED



3 **LINEAR LED**
FINISH: ALUMN. HOUSING / ACRYLIC LENS
COLOR: 3500K
MOUNT: SURFACE

EXTERIOR LIGHTING PLAN

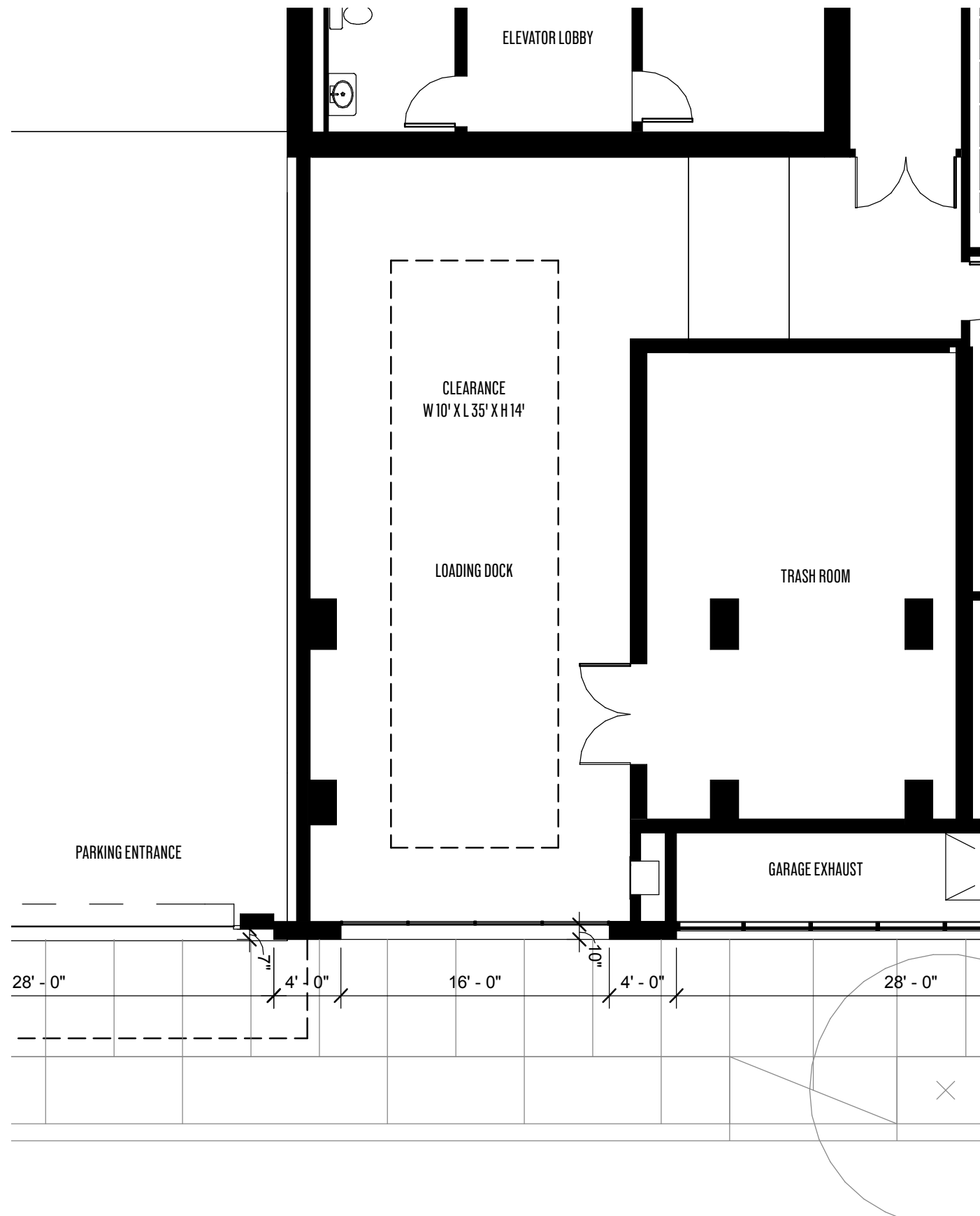

FLOOR PLAN - GROUND FLOOR LOADING DOCK



EAST ELEVATION AT LOADING DOCK DOOR



REPRESENTATIVE IMAGE OF TRANSLUCENT GLASS SECTIONAL OVERHEAD DOOR

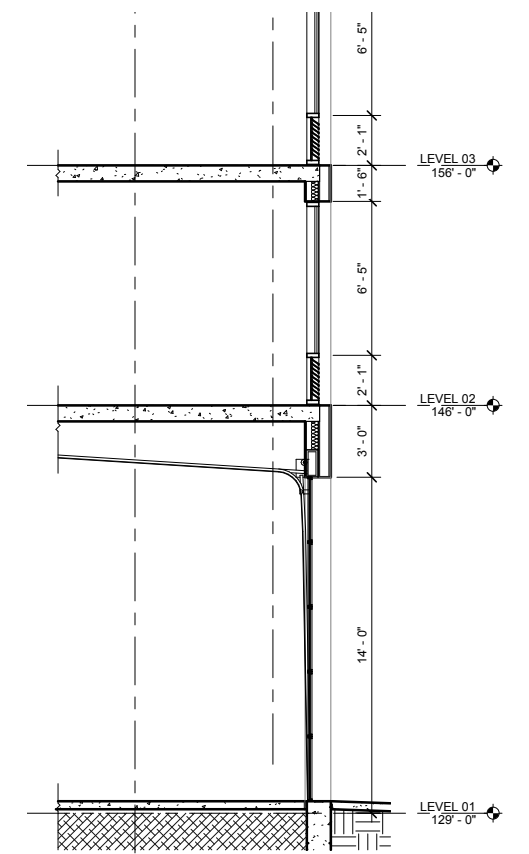

SECTION AT OVERHEAD DOOR

LOADING DOCK



View of Block 102 from NE Holladay St



View of Block 102 from Oregon Square



View of Block 102 from the corner of NE Holladay St & NE 9th Ave.



View of Block 102's pass-through lobby from NE Holladay St.