



WEATHERLY BUILDING

KEYBANK





STREET TREES W/O POWER LINE

STREET TREES WITH POWER LINE



PYRMIDAL EUROPEAN HORNBEAM



GINKGO SARATOGA



FOREST GREEN OAK



POWERLINE TO REMAIN

LANDSCAPE MATERIALS



CONCRETE PAVERS/WOOD BENCH



CONCRETE PAVERS



CONCRETE PAVING



COBBLE



SCUPPER



STEEL PLANTER

STORMWATER PLANTS



VINE MAPLE



CALIFORNIA GRAY RUSH



ORANGE SEDGE



SWORD FERN

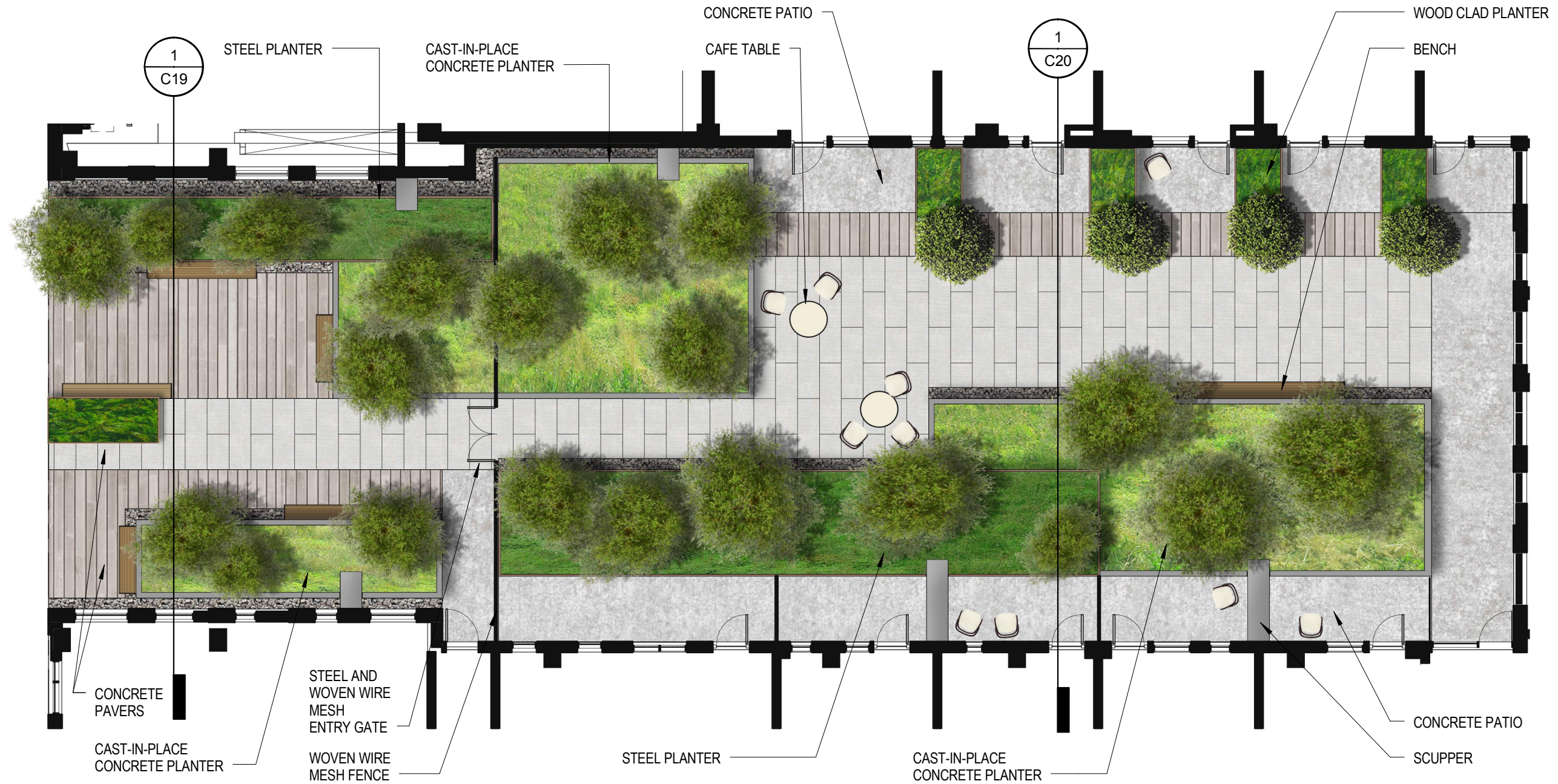

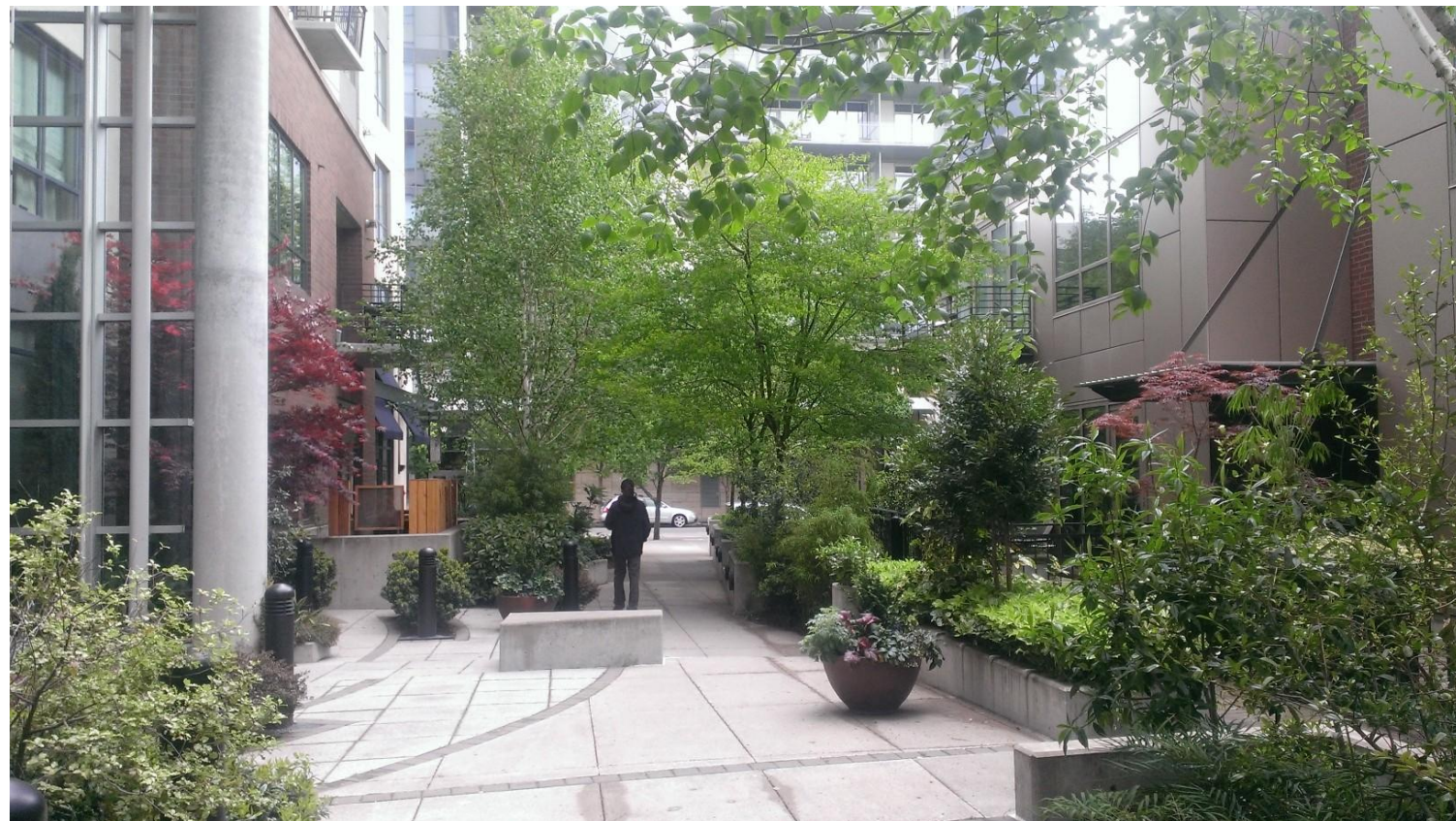

PARK PLACE - 30'



THE SITKA - 40'



BRIDGEPORT - 40'



THE RAMONA - 40'









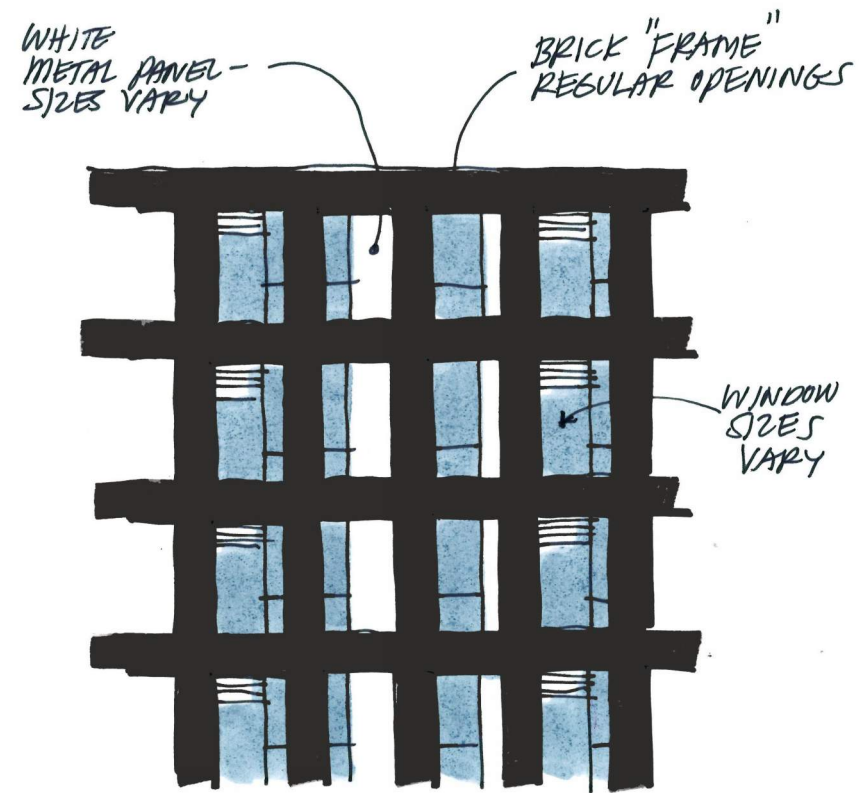

FACADE DIAGRAM

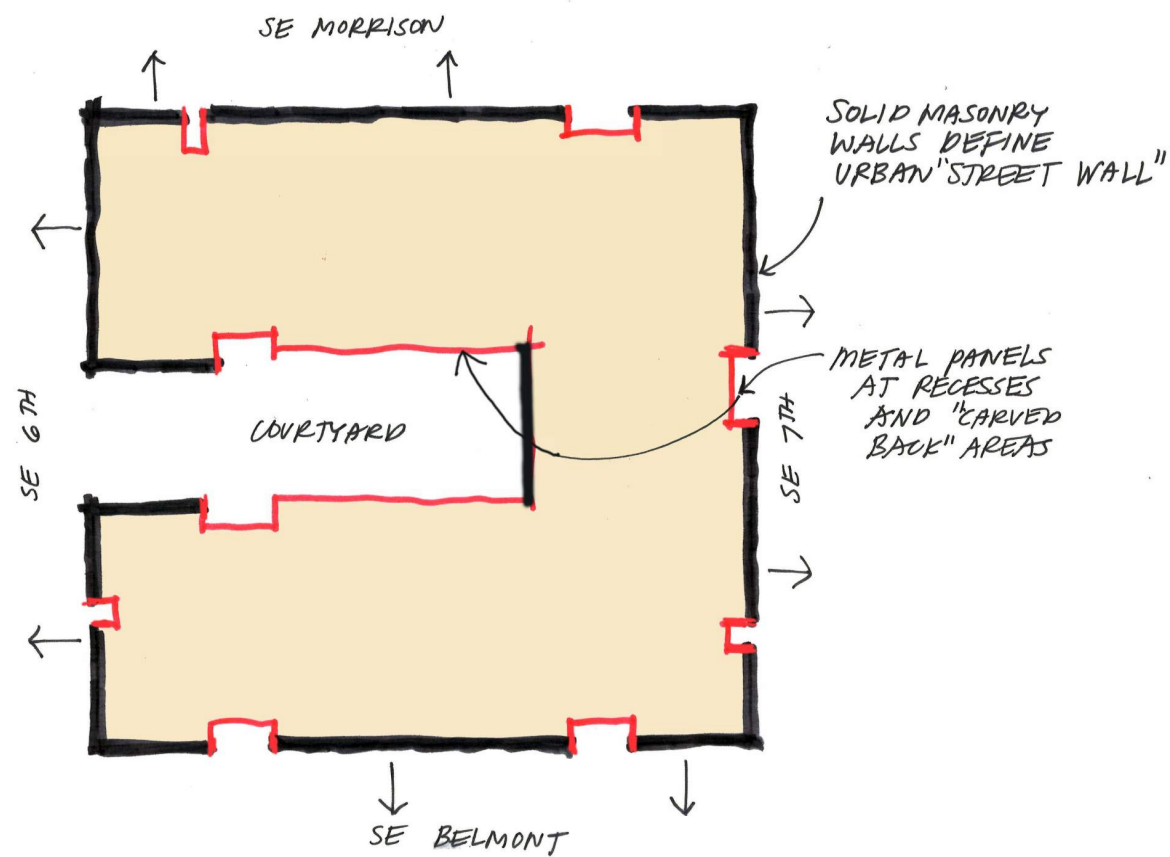

PLAN DIAGRAM

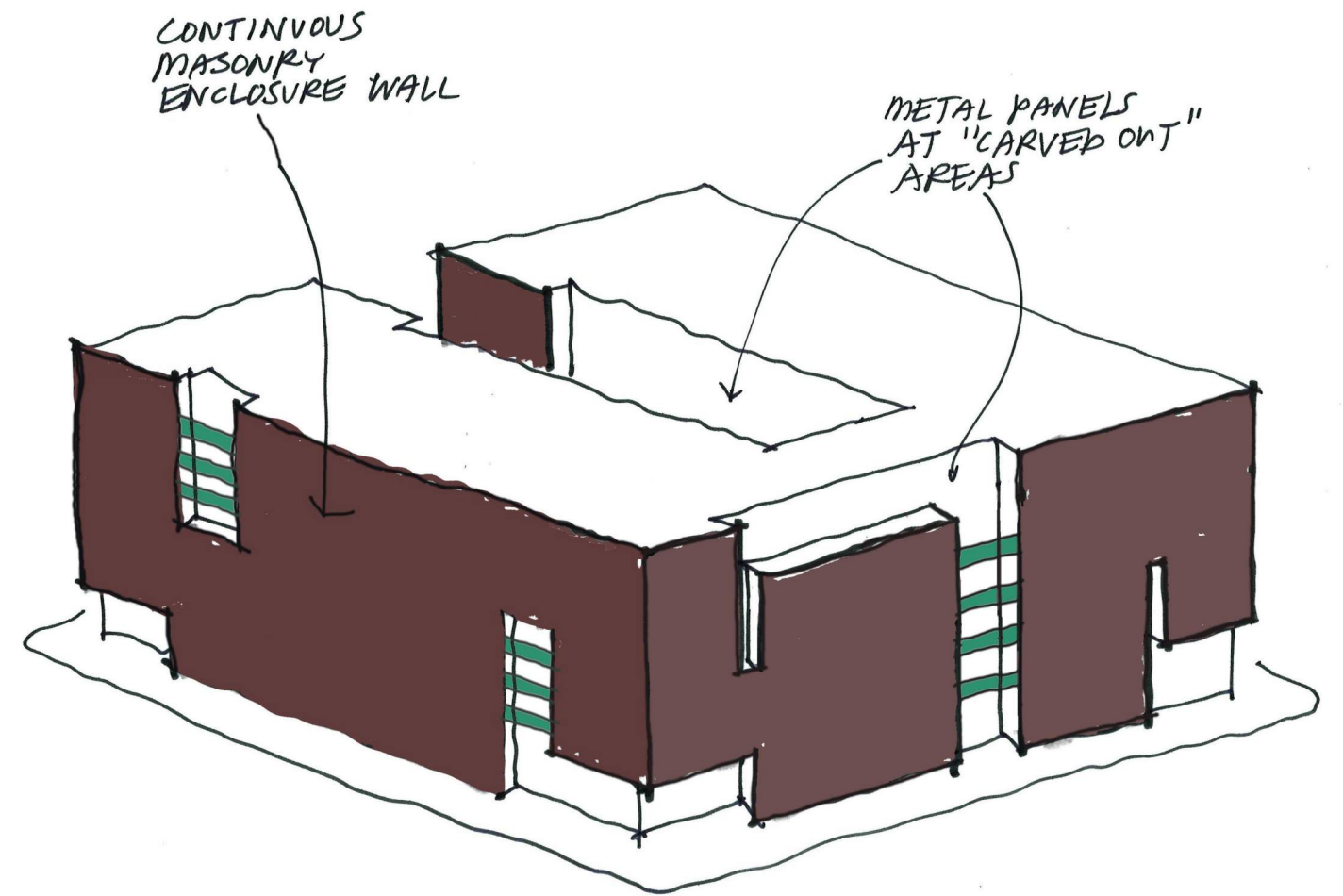

MASSING DIAGRAM



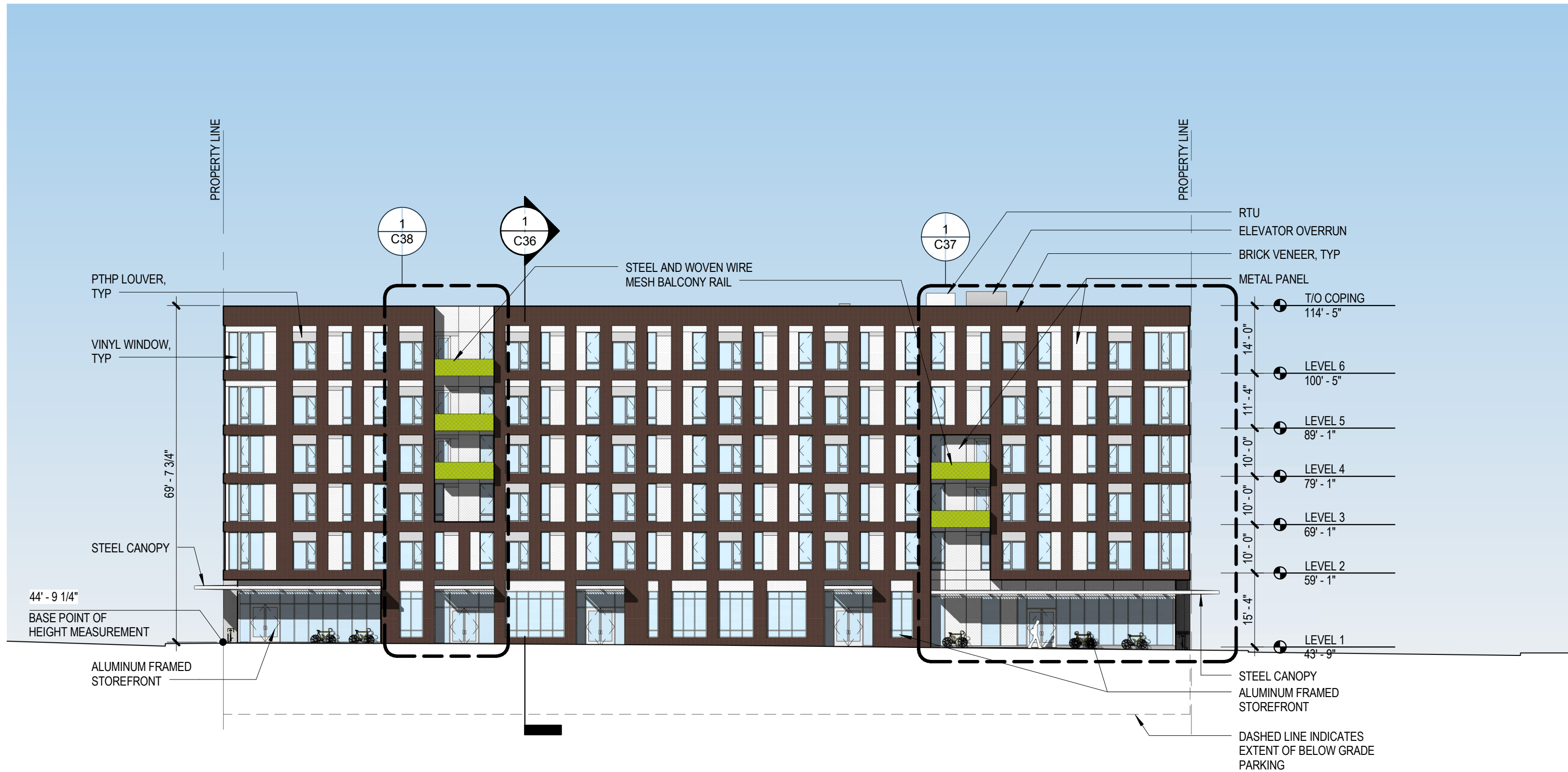



PROPERTY LINE

PROPERTY LINE

METAL PANEL

STEEL CANOPY

ALUMINUM FRAMED
STOREFRONT

BRICK VENEER, TYP

METAL PANEL

T/O COPING
114' - 5"

LEVEL 6
100' - 5"

LEVEL 5
89' - 1"

LEVEL 4
79' - 1"

LEVEL 3
69' - 1"

LEVEL 2
59' - 1"

STEEL CANOPY
LEVEL 1
43' - 9"

STEEL CANOPY

DASHED LINE INDICATES
EXTENT OF BELOW GRADE
PARKING







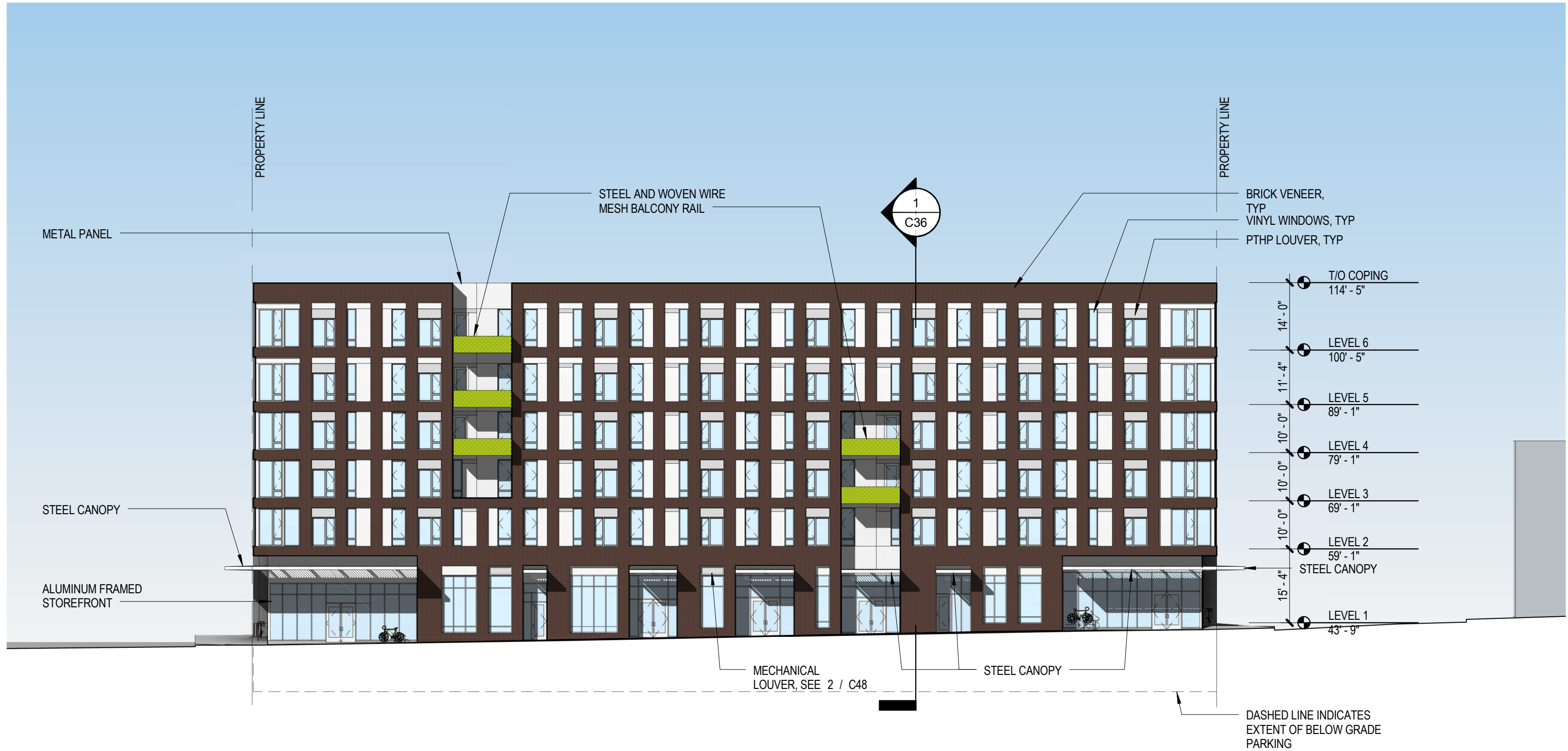







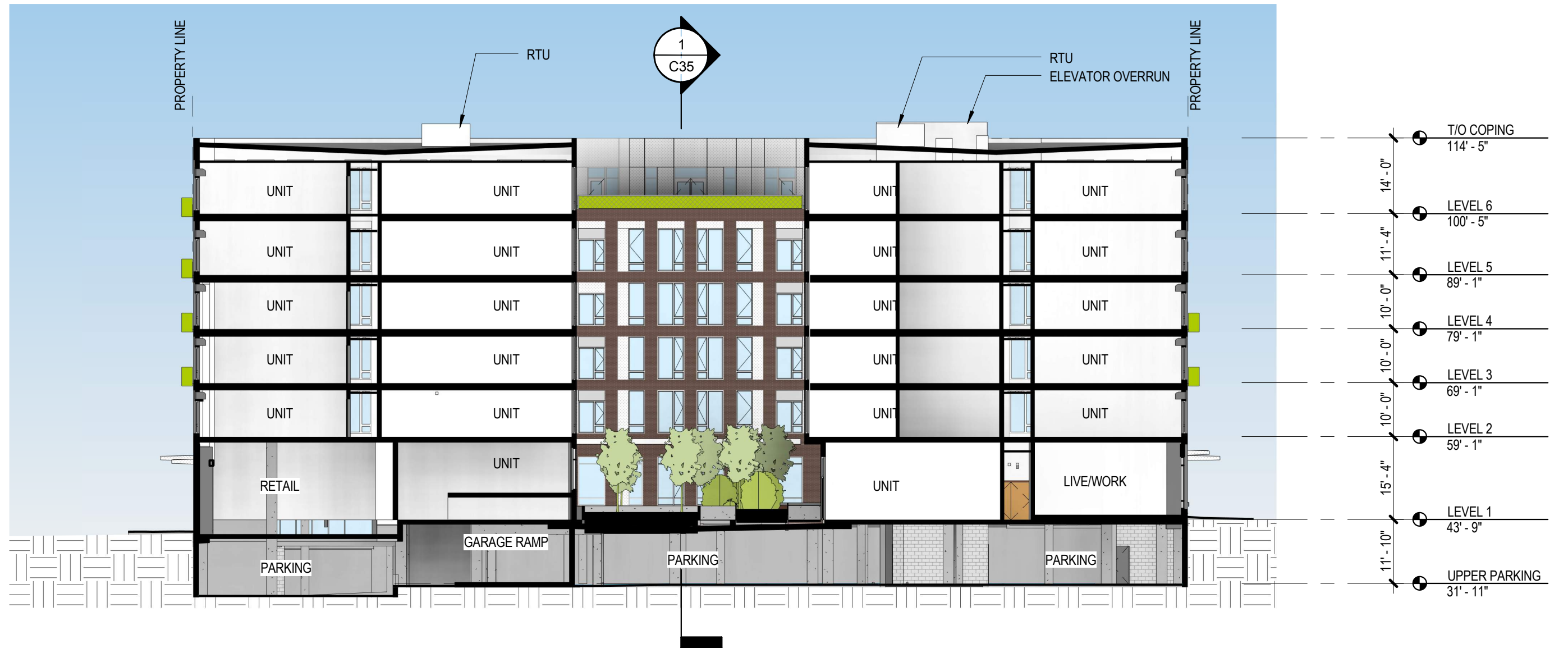

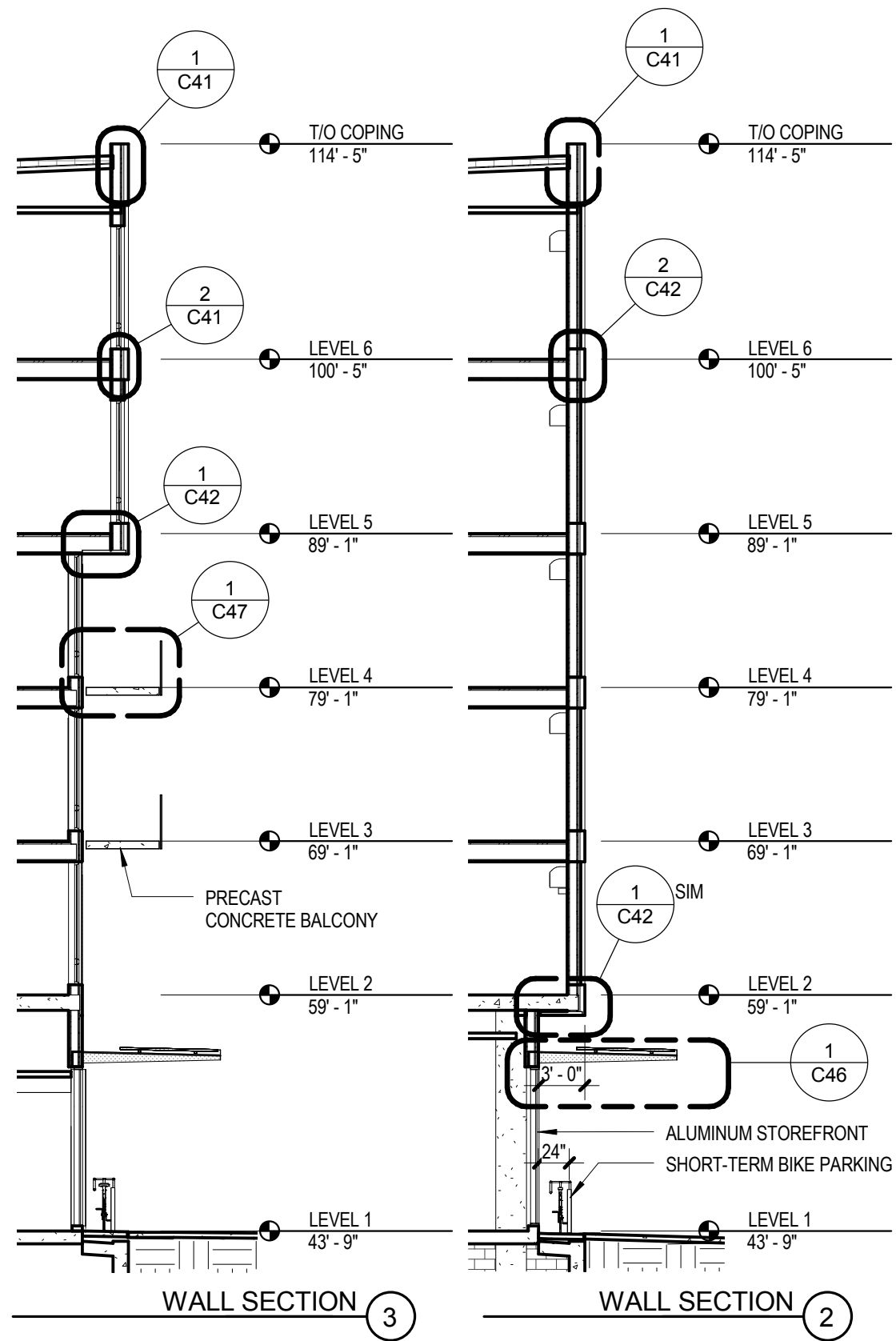

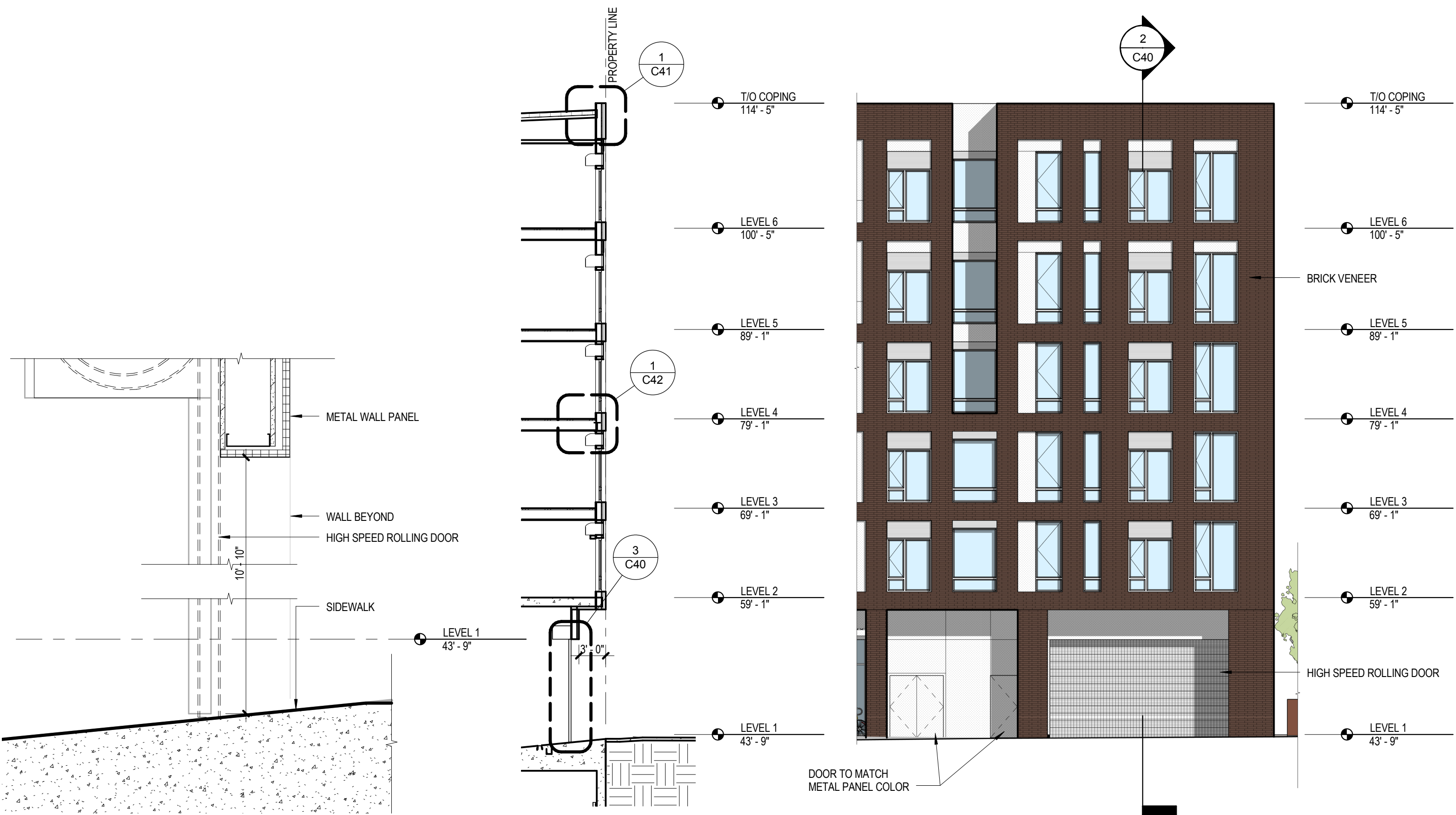

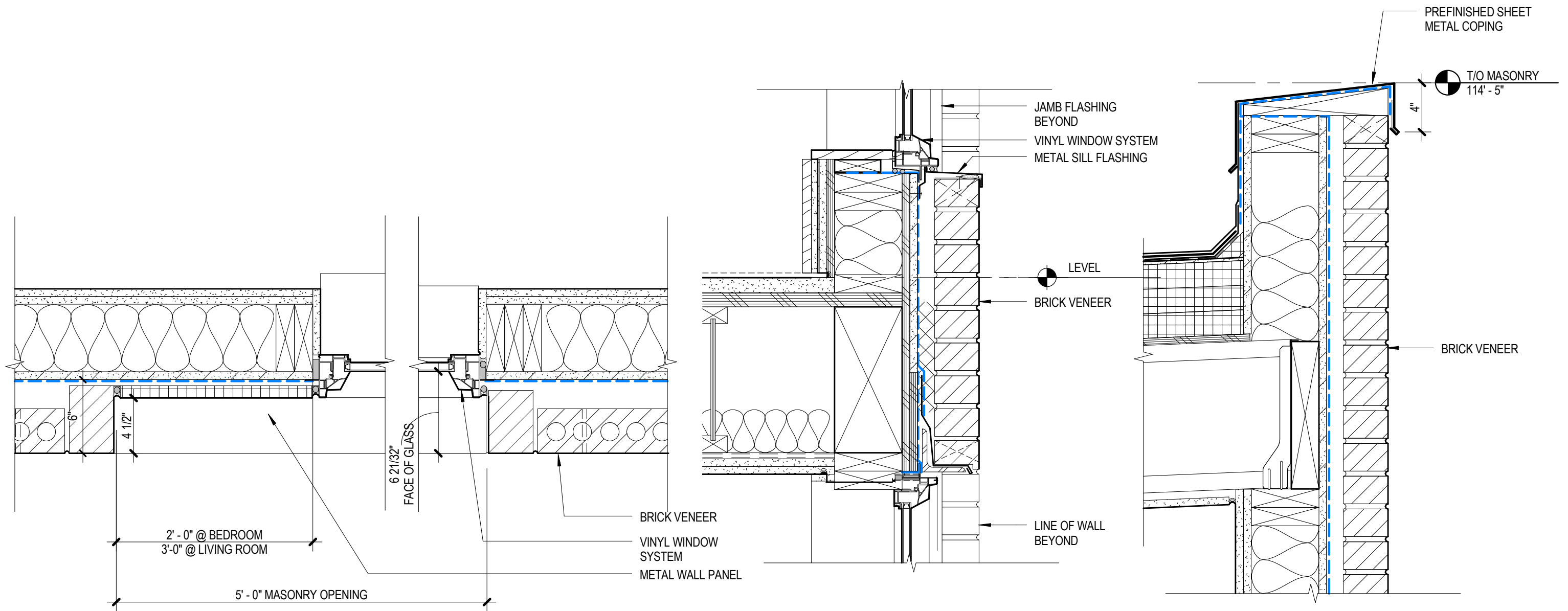

METAL PANEL TO BRICK TRANSITION
 1 1/2" = 1'-0" ④

TYP WINDOW JAMB
 1 1/2" = 1'-0" ③

TYP HEAD & SILL AT BRICK
 1 1/2" = 1'-0" ②

PARAPET AT BRICK
 1 1/2" = 1'-0" ①

937 BUILDING



3" BRICK RETURN

THE JANEY

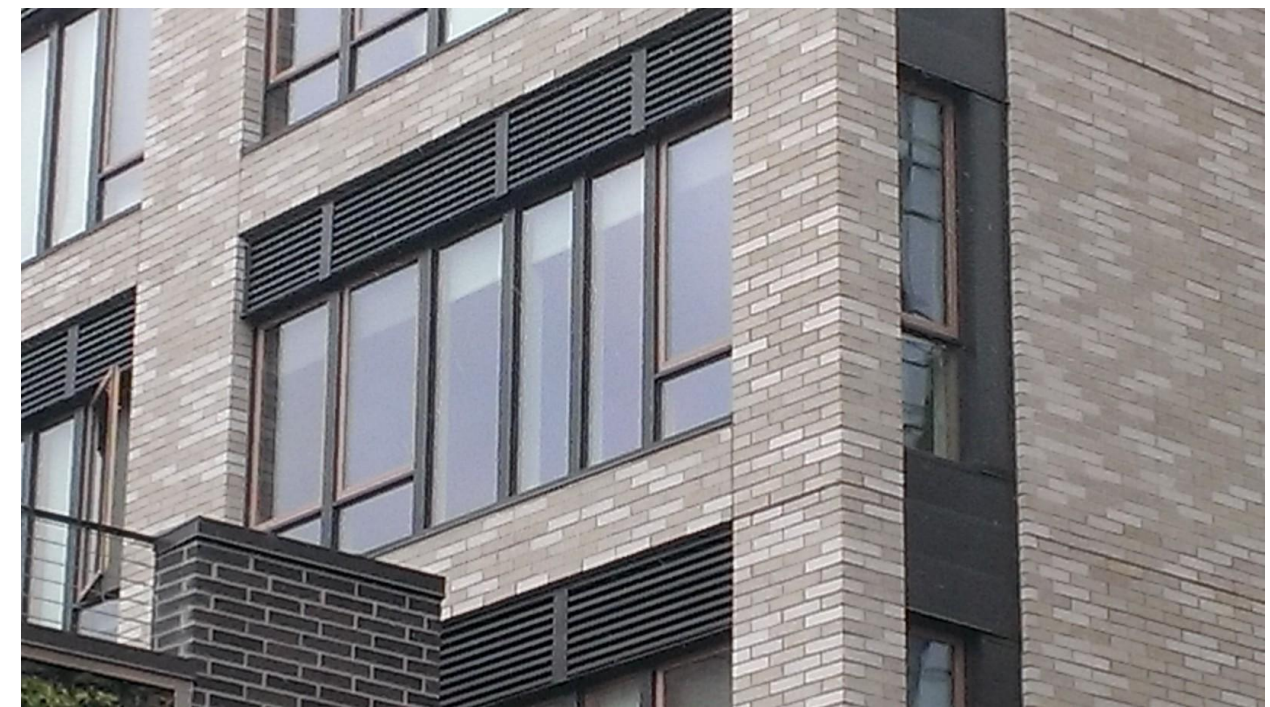

4 1/2" TO WINDOW, 1" TO METAL PANEL

BUD CLARK COMMONS



4 1/2" BRICK RETURN



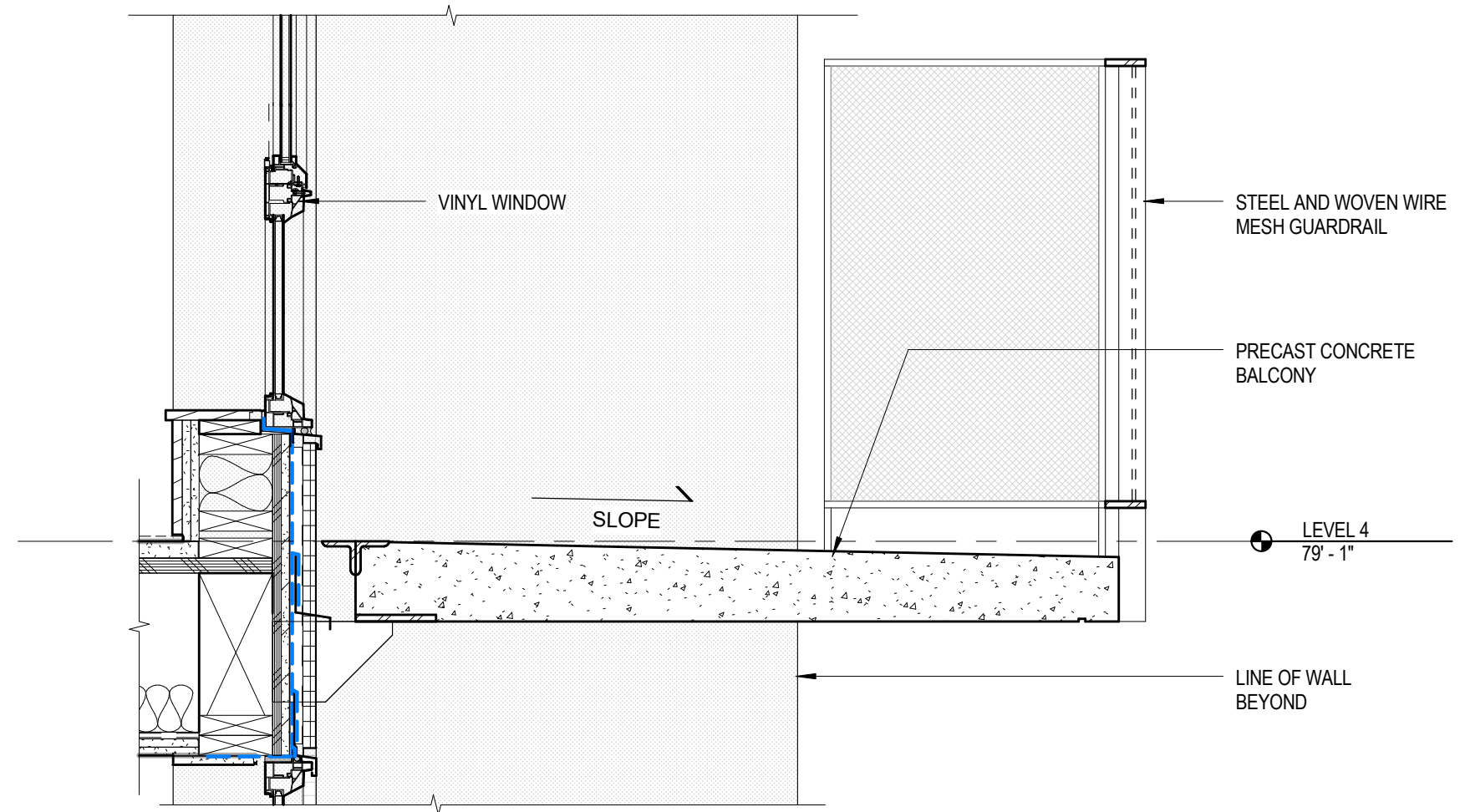

SECTION AT BALCONY ①



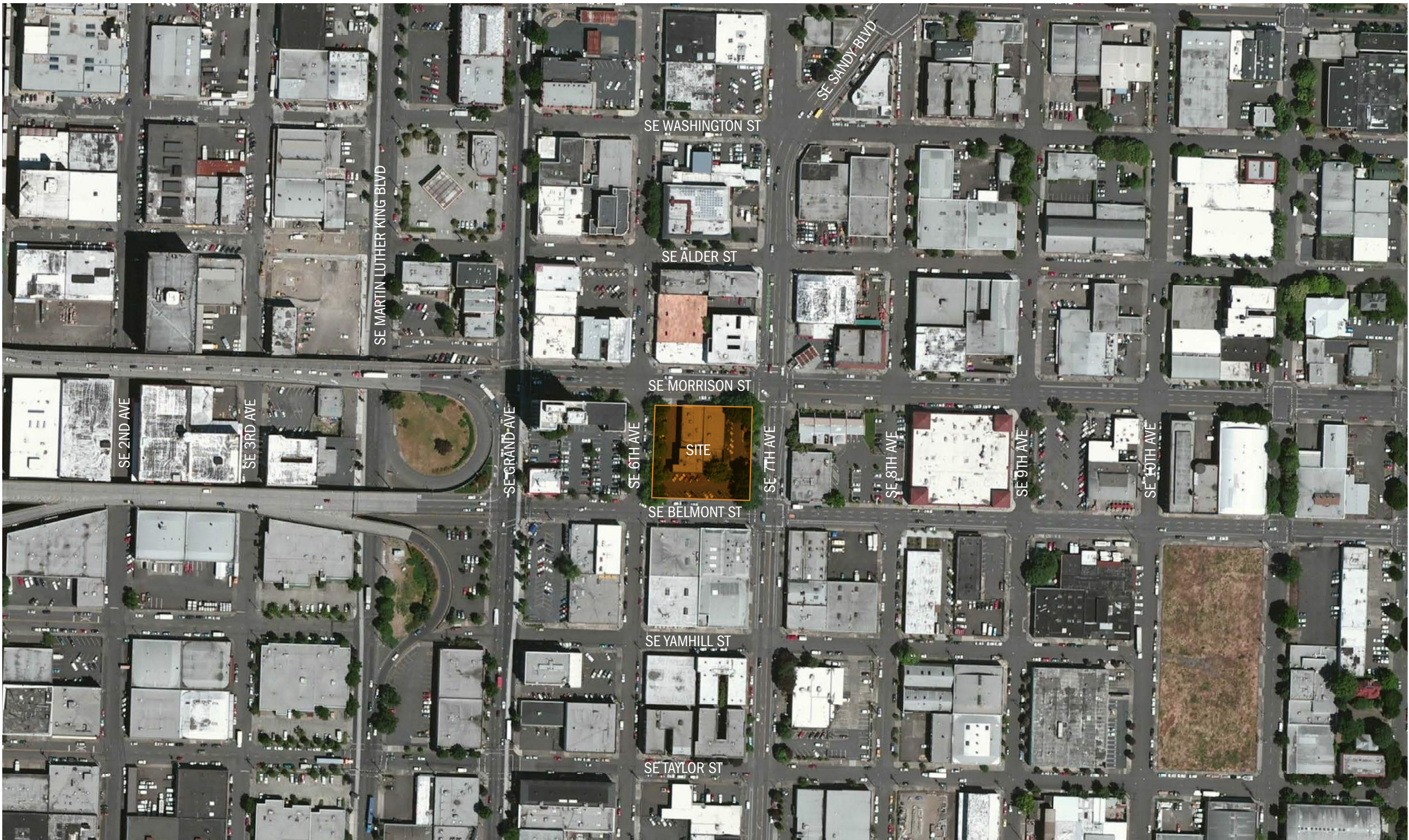

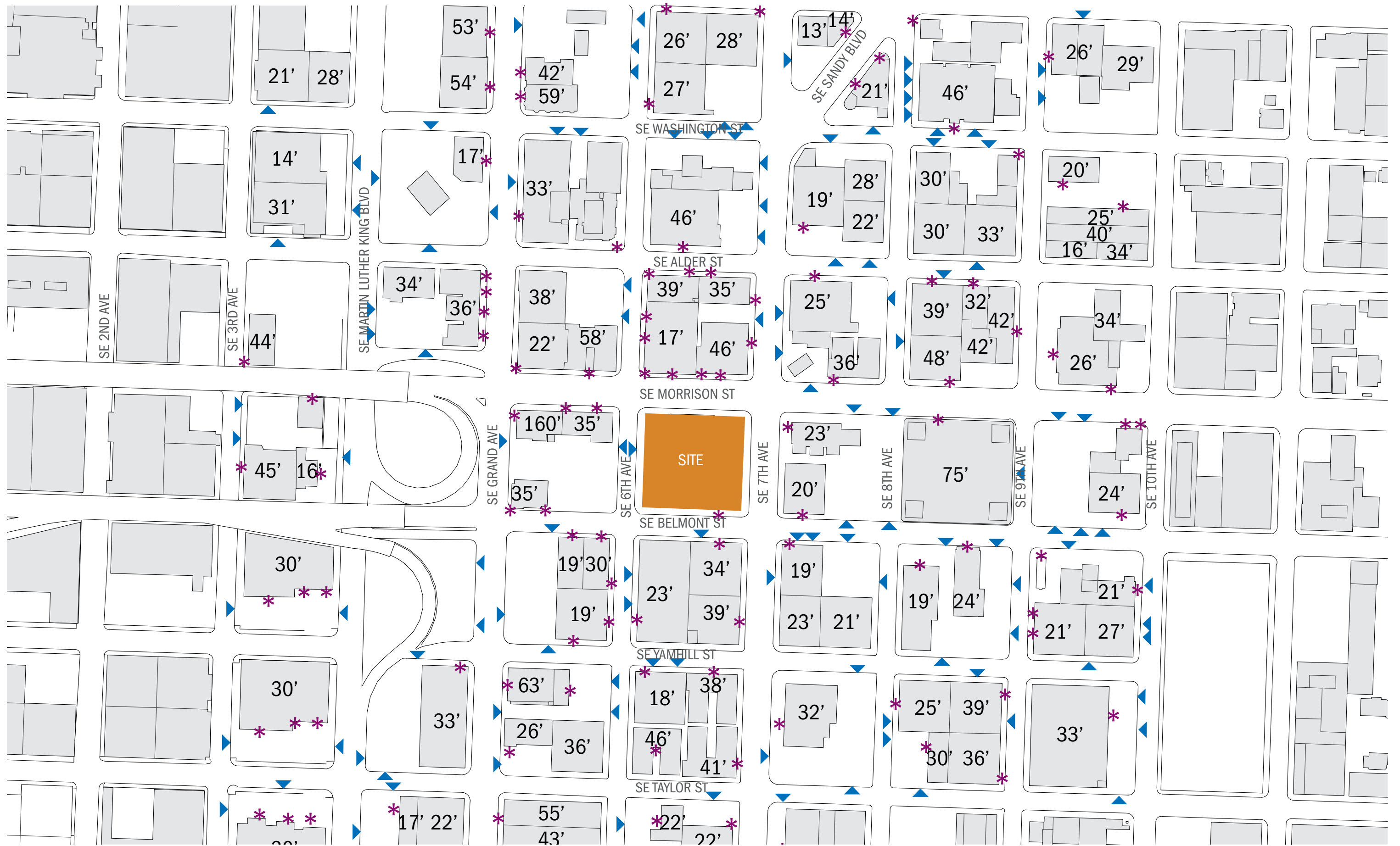

TABLE OF CONTENTS

SE VIEW	C1
SE VIEW	C2
TABLE OF CONTENTS	C3
NE VIEW	C4
NW VIEW	C5
VIEW INTO COURTYARD	C6
VICINITY MAP	C7
BLOCK STUDY	C8
SITE AND CONTEXT PHOTOS	C9
PRECEDENTS	C10
MASSING DIAGRAMS	C11
GRADING PLAN	C12
SITE UTILITY PLAN	C13
COURTYARD RENDERINGS	C14
LANDSCAPE SITE PLAN	C15
LANDSCAPE COURTYARD PLAN	C16
LANDSCAPE PLANTING PLAN	C17
LANDSCAPE TERRACE PLAN	C18
LANDSCAPE COURTYARD SECTION	C19
LANDSCAPE COURTYARD SECTION	C20
LANDSCAPE DETAILS	C21
FAR DIAGRAMS	C22
PARKING LEVEL	C23
GROUND FLOOR PLAN	C24
LEVELS 2-5	C25
LEVEL 6	C26
ROOF PLAN	C27
ENLARGED BIKE PARKING PLANS	C28
SOUTH ELEVATION	C29
EAST ELEVATION	C31
NORTH ELEVATION	C32
WEST ELEVATION	C33
COURTYARD ELEVATIONS	C34
BUILDING SECTION E/W	C35
BUILDING SECTION N/S	C36
ENLARGED ELEVATIONS	C37
ENLARGED ELEVATIONS	C38
ENLARGED ELEVATIONS	C39
ENLARGED ELEVATIONS	C40
EXTERIOR DETAILS	C41
EXTERIOR DETAILS	C42
EXTERIOR DETAILS	C43
EXTERIOR DETAILS	C44
EXTERIOR DETAILS	C45
CANOPY DETAILS	C46
EXTERIOR DETAILS - BALCONY	C47
EXTERIOR DETAILS - LOUVERS	C48
EXTERIOR LIGHTING PLAN	C49
MATERIALS	C50







30' BUILDING FOOT PRINT AND HEIGHT ABOVE GRADE
 * PEDESTRIAN ACCESS
▶ VEHICLE ACCESS
100'





LOCA



APPROACH ON SE MORRISON ST



CLIFFORD APARTMENTS

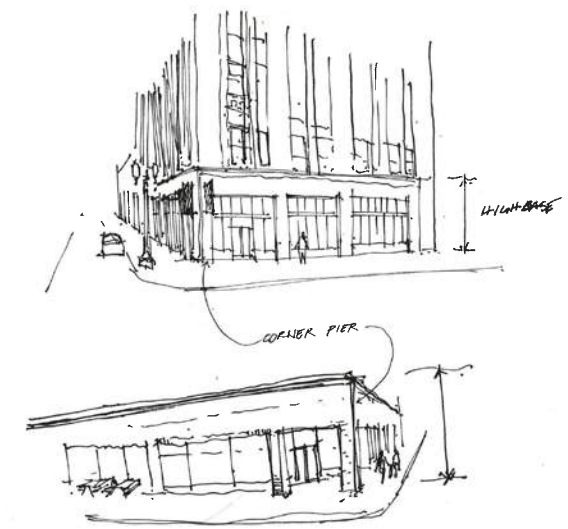

SHEET LEGEND	
TP XXX.XX	GRADE AT TOP OF PAVEMENT
TC XXX.XX	GRADE AT TOP OF CURB
G XXX.XX	GRADE AT GUTTER
(E)	EXISTING
X.X%	SLOPE ARROW
- - - 286 - - -	EXISTING CONTOUR

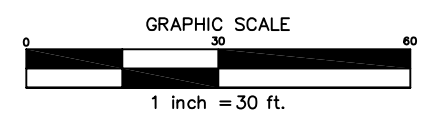
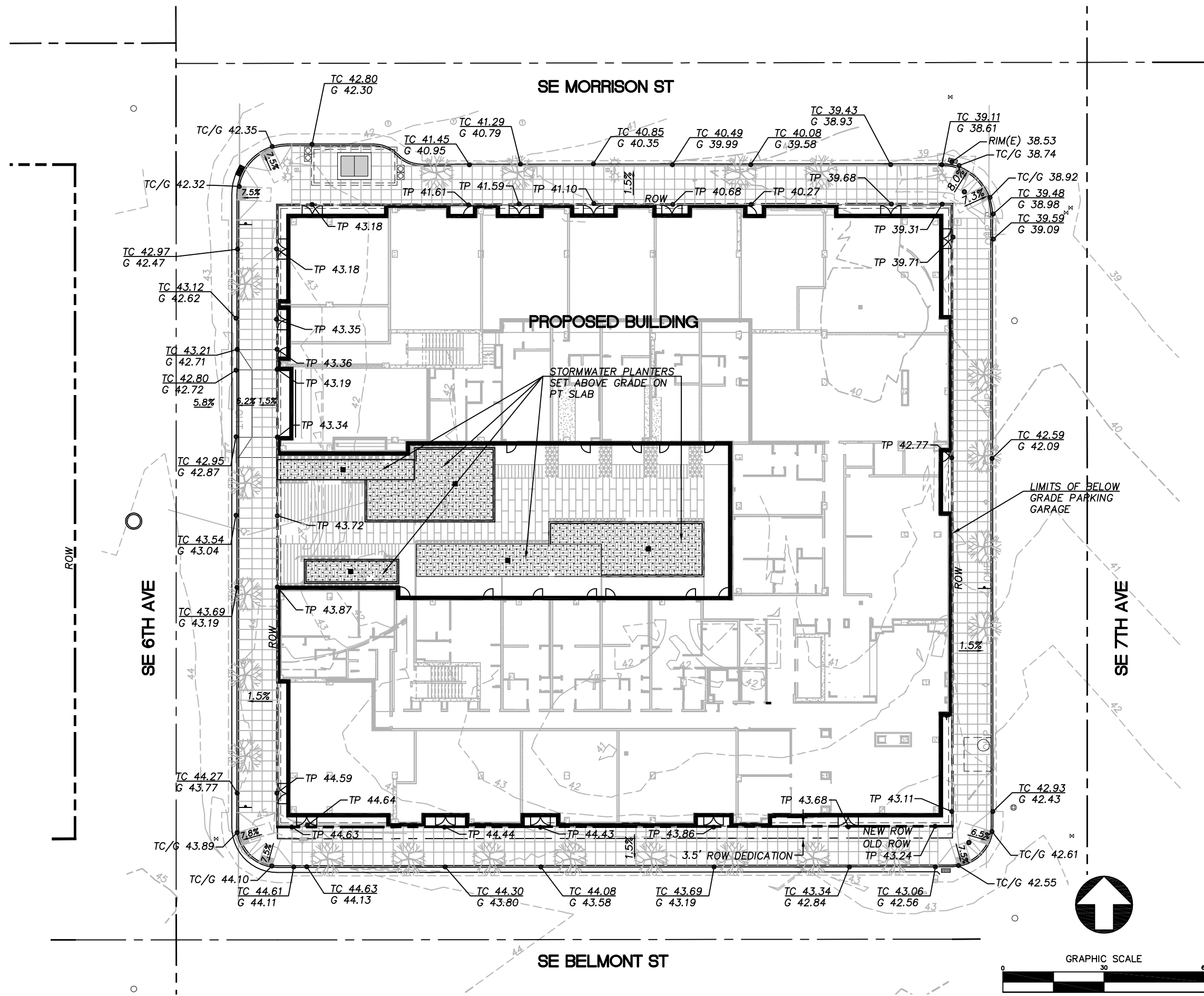

STORMWATER NARRATIVE

PRIVATE SITE:

WATER QUALITY
 WATER QUALITY CONTROL IS MET WITH FLOW-THROUGH PLANTERS. THE PLANTERS ARE SIZED TO TREAT ALL ROOF AREA. A SPECIAL CIRCUMSTANCE WILL BE REQUESTED TO MITIGATE RUNOFF FROM THE COURTYARD AND ROOF TERRACE.

WATER QUANTITY
 WATER QUANTITY CONTROL IS ALSO MET WITH FLOW-THROUGH PLANTERS WHICH ARE SIZED TO SLOW DOWN THE PEAK FLOW RATE FOR THE 25 YR STORM EVENT.

DISPOSAL
 INFILTRATION IS NOT POSSIBLE DUE TO BELOW GRADE PARKING GARAGE COVERING ENTIRE SITE. ALL RUNOFF FROM THE SITE WILL BE PIPED TO THE 66" COMBINED SEWER PIPE IN SE 7TH AVENUE. THE PROJECT WILL FALL UNDER CATEGORY 4 OF THE STORMWATER DISPOSAL HIERARCHY.

PUBLIC STREET IMPROVEMENTS:
 STORMWATER MANAGEMENT IS NOT REQUIRED FOR THE IMPROVEMENTS TO THE PUBLIC SIDEWALKS IN THE PUBLIC RIGHT OF WAY. THE EXISTING STORMWATER DRAINAGE FOR THE RIGHT OF WAY WILL BE PROTECTED DURING CONSTRUCTION.

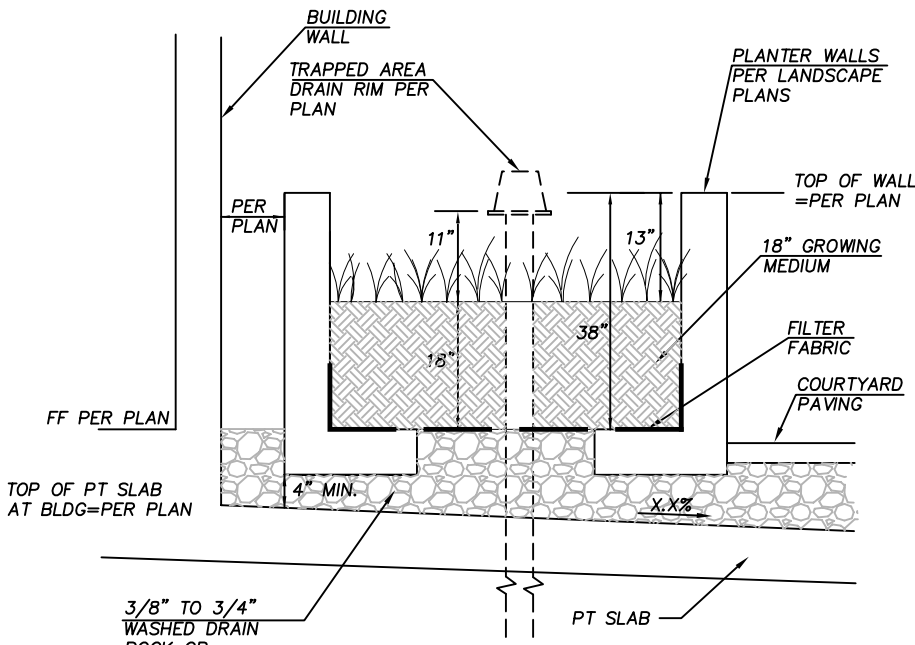
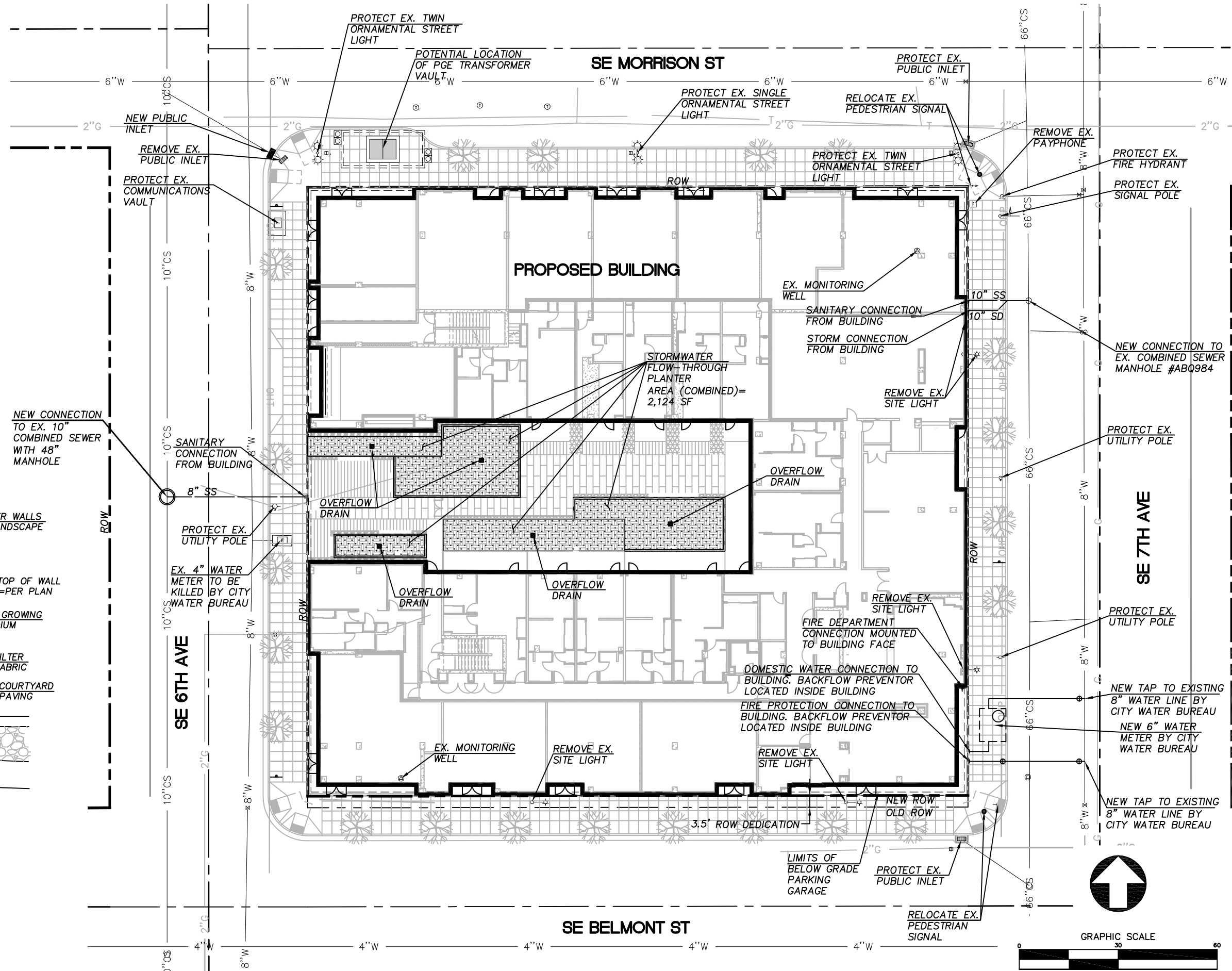

- NOTES:**
1. PLANTING PER LANDSCAPING PLANS.
 2. GROWING MEDIUM PER SPECIFICATIONS.

1 STORMWATER FLOW-THROUGH PLANTER
 NTS

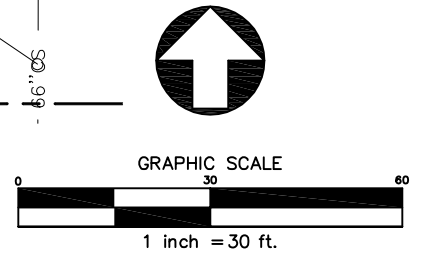

PLANT MATERIAL SCHEDULE

TYPE	SYMBOL	BOTANICAL NAME	COMMON NAME	SIZE	SPACING
TREES		ACER CIRCINATUM	VINE MAPLE	3" CALIPER-MULTI TRUNK	PER PLAN
ENTRY TREES		PYRUS CALLERYANA 'CAPITOL'	CAPITOL PEA	2.5" CALIPER	PER PLAN
SHRUBS		NANDINA DOMESTICA 'HARBOUR DWARF'	HEAVENLY BAMBOO	5-GALLON	24" ON-CENTER
		CORNUS SERICEA	RED-TWIG DOGWOOD	2 GALLON	48" ON-CENTER
HERBACEOUS PLANTS/ GRASSES		CAREX TESTACEA	NEW ZEALAND ORANGE SEDGE	1 GALLON	12" ON-CENTER
		JUNCUS PATENS	SPREADING RUSH	1 GALLON	12" ON-CENTER
		POLYSTICHUM MUNITUM	SWORDFERN	1 GALLON	12" ON-CENTER

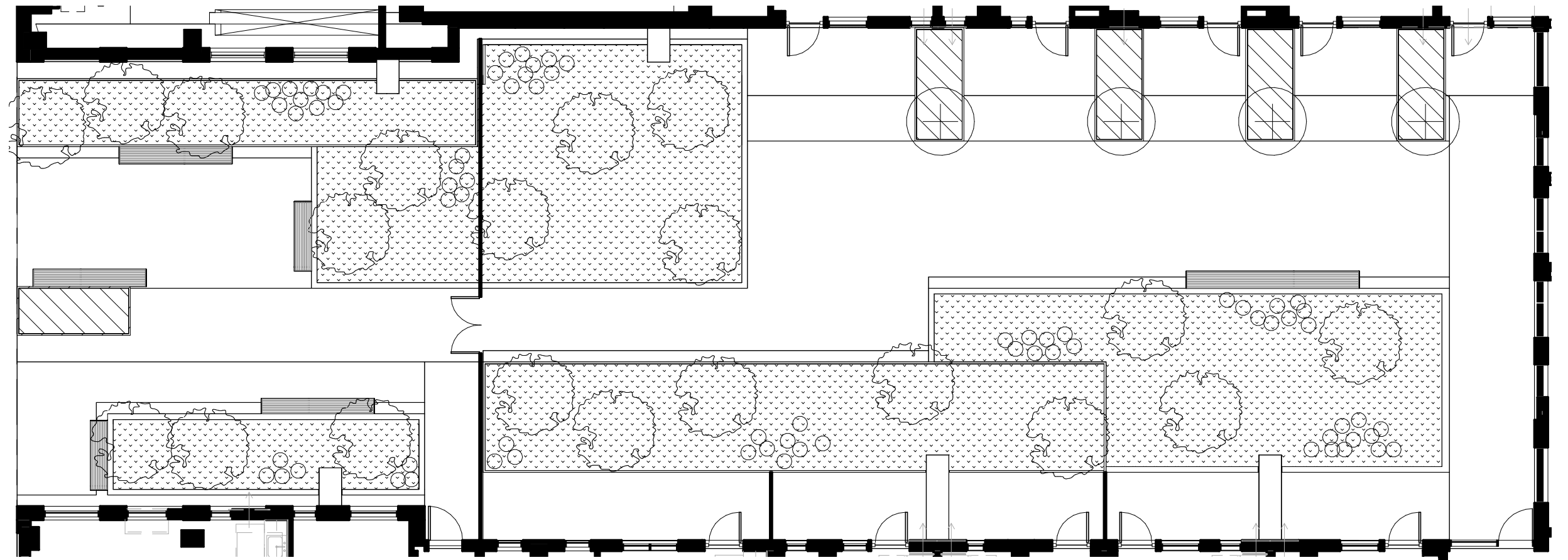

COURTYARD PLANTING PLAN 1

LANDSCAPE MATERIALS



FIRE TABLE



TERRACE CHARACTER



PLANTER POTS



OUTDOOR FURNITURE



CONCRETE PAVERS



PLANTER POTS

PLANTS



SCREENING SHRUB



ORNAMENTAL GRASS



PERENNIALS

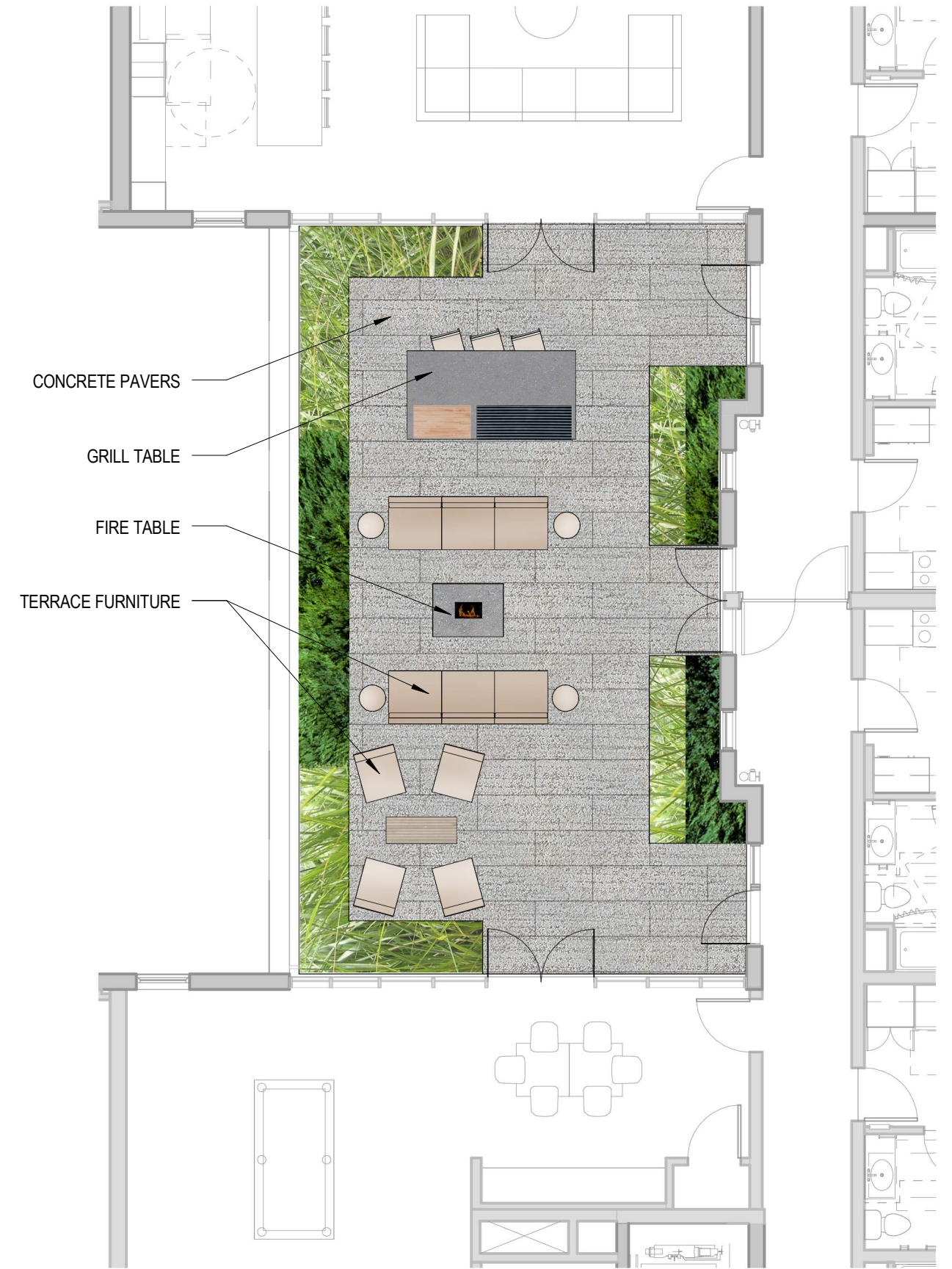

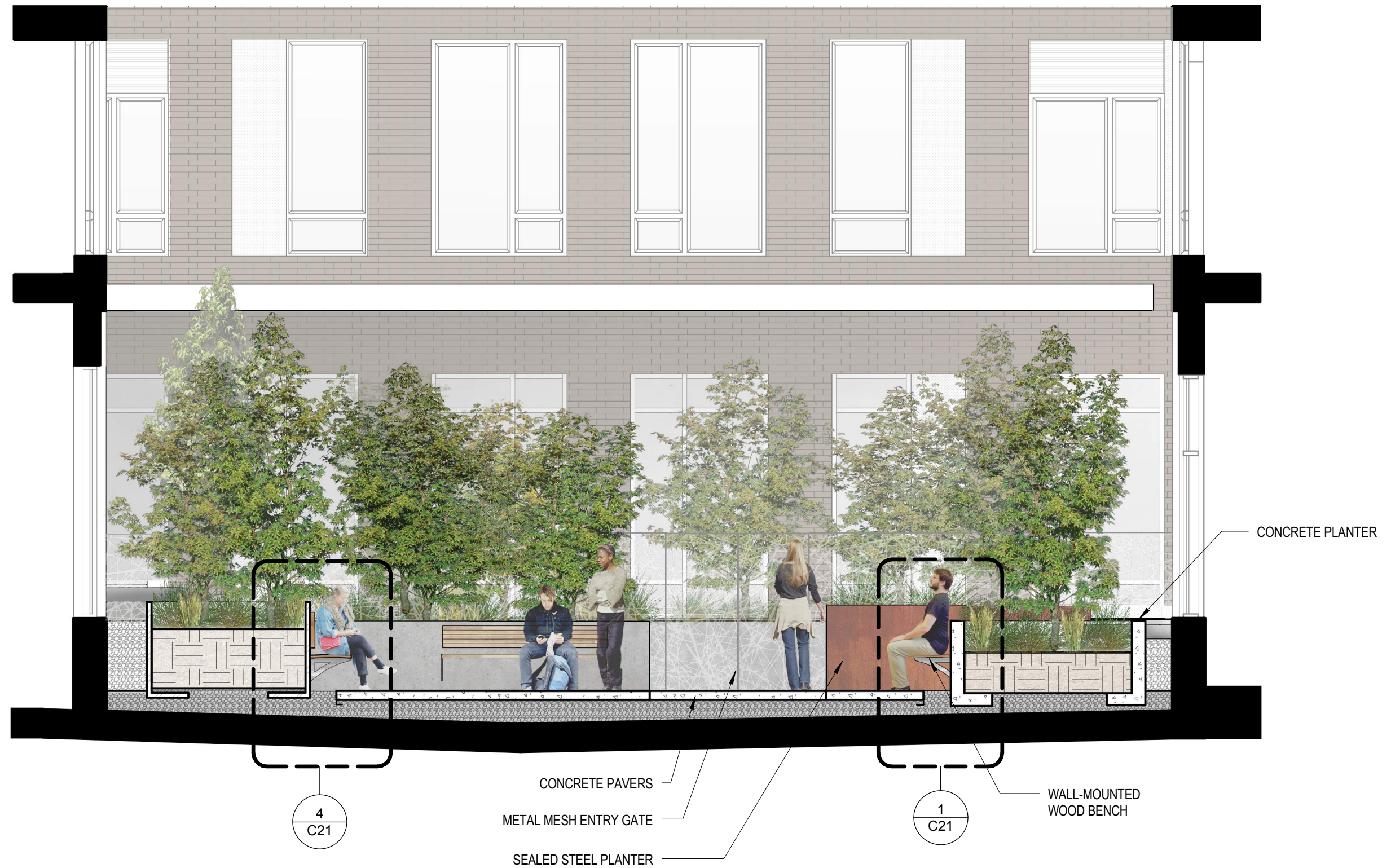



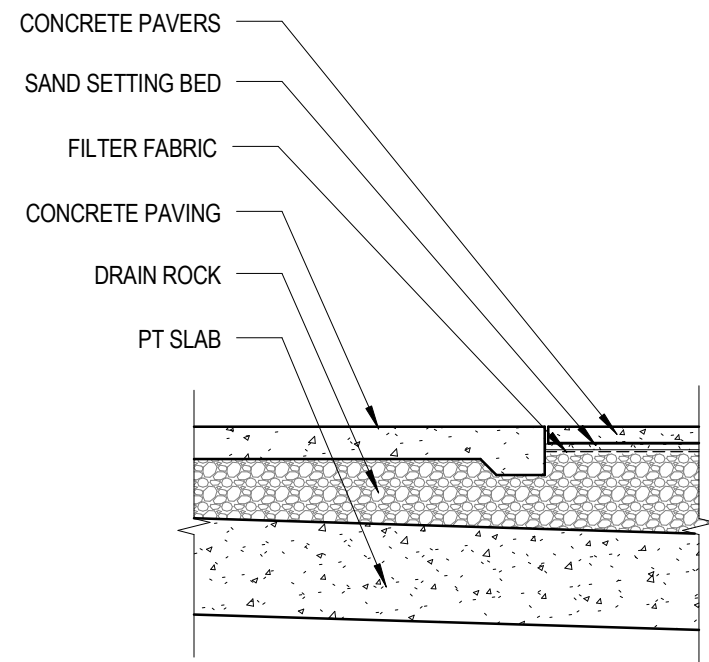

PATIO TO PAVER DETAIL 3
1/2" = 1'-0"

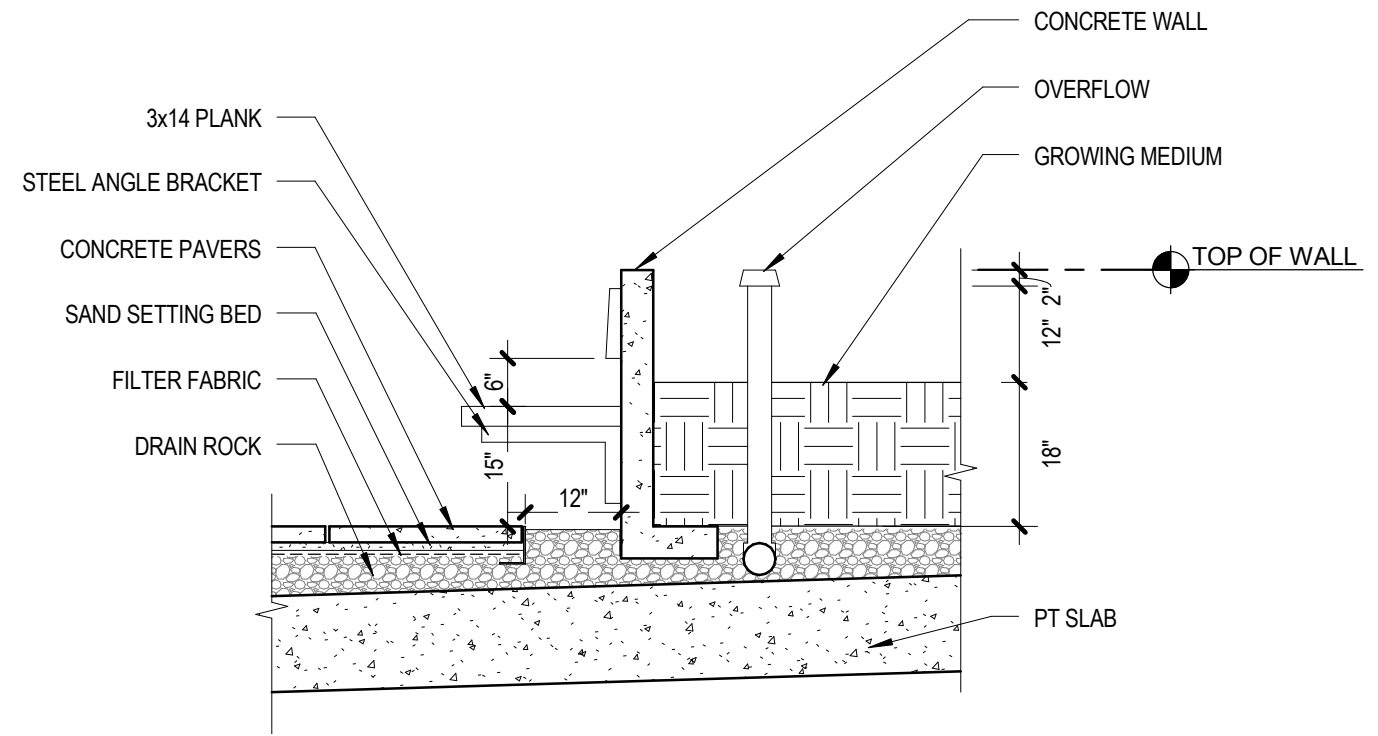

CONCRETE PLANTER (LOW) AT PAVERS 1
1/2" = 1'-0"

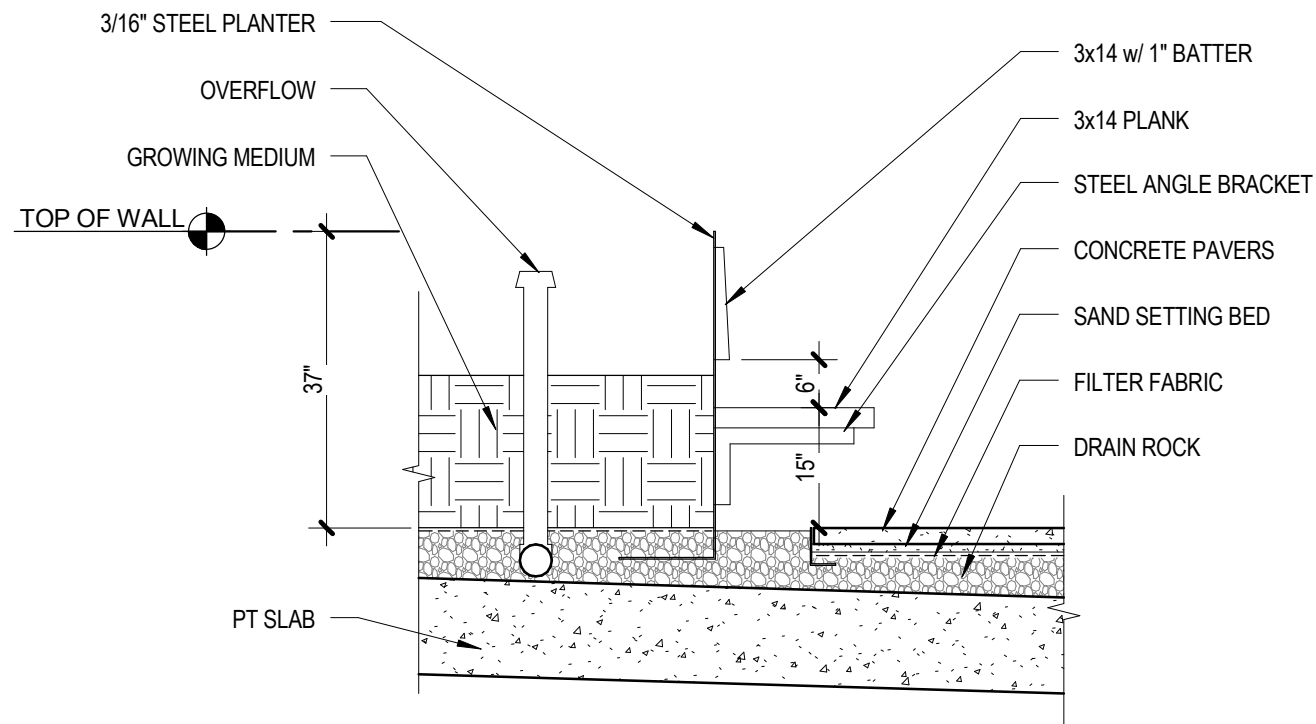

STEEL PLANTER (HIGH) AT PAVERS 4
1/2" = 1'-0"

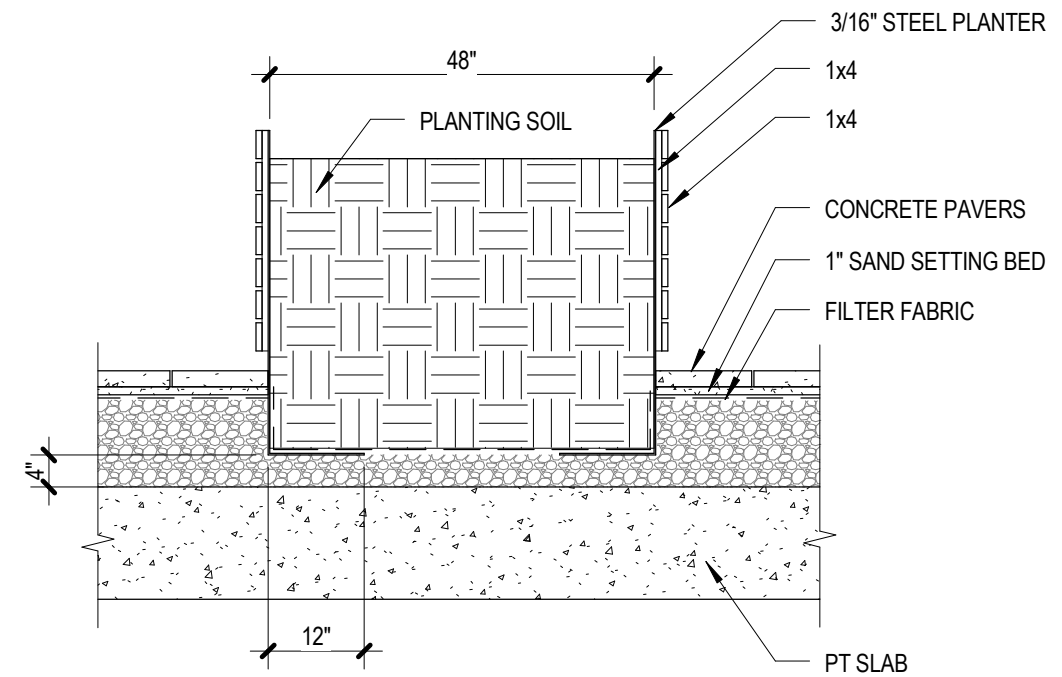

WOOD CLAD PLANTER 2
1/2" = 1'-0"

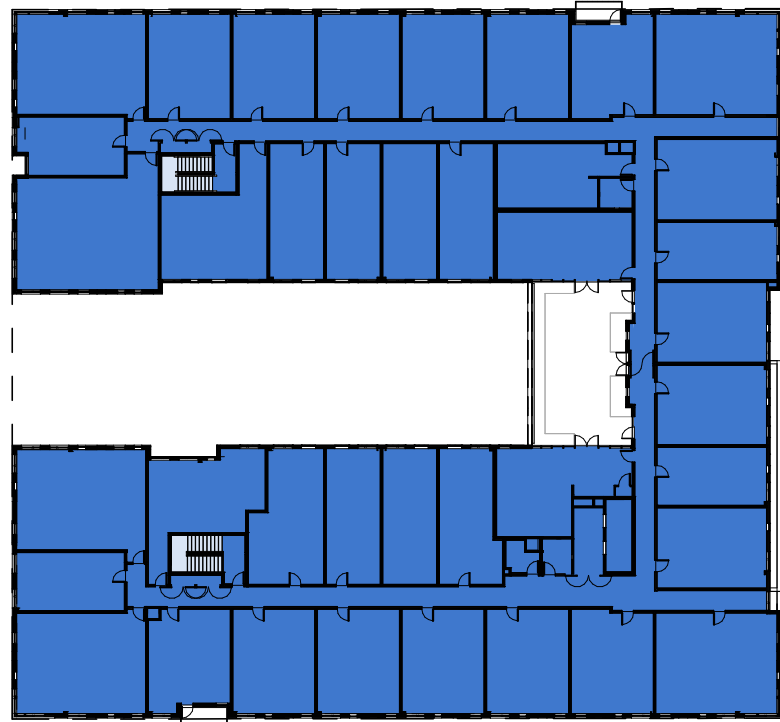

LEVEL 6 ③

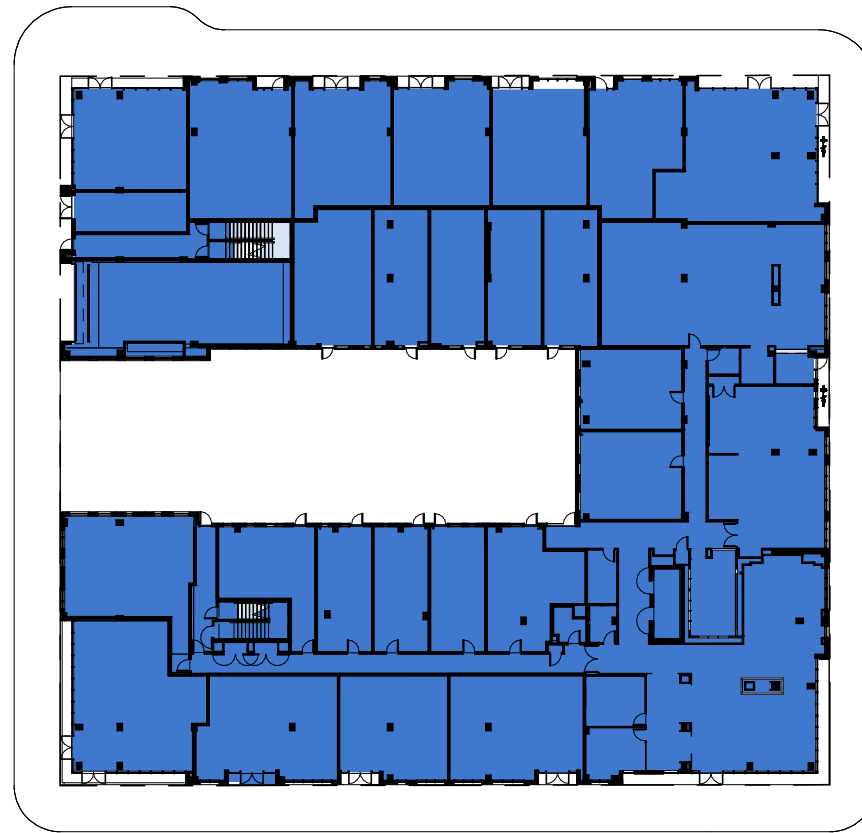

LEVEL 1 ①

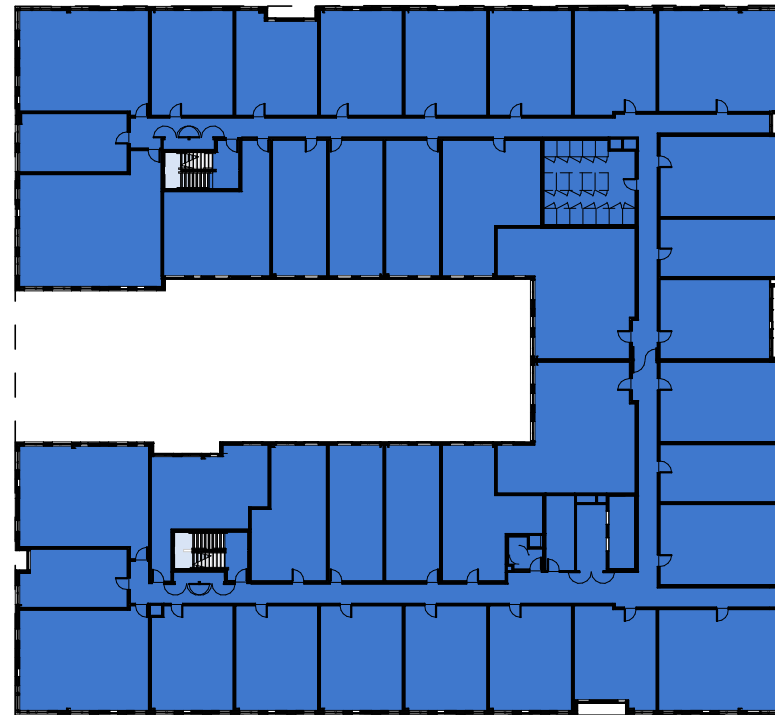

LEVELS 2-5 ②

29,618 SF	LEVEL 1
31,093 SF	LEVEL 2
31,019 SF	LEVEL 3
31,003 SF	LEVEL 4
31,093 SF	LEVEL 5
29,792 SF	LEVEL 6
<hr/>	<hr/>
183,618 SF	FAR TOTAL

332,235 SF ALLOWABLE

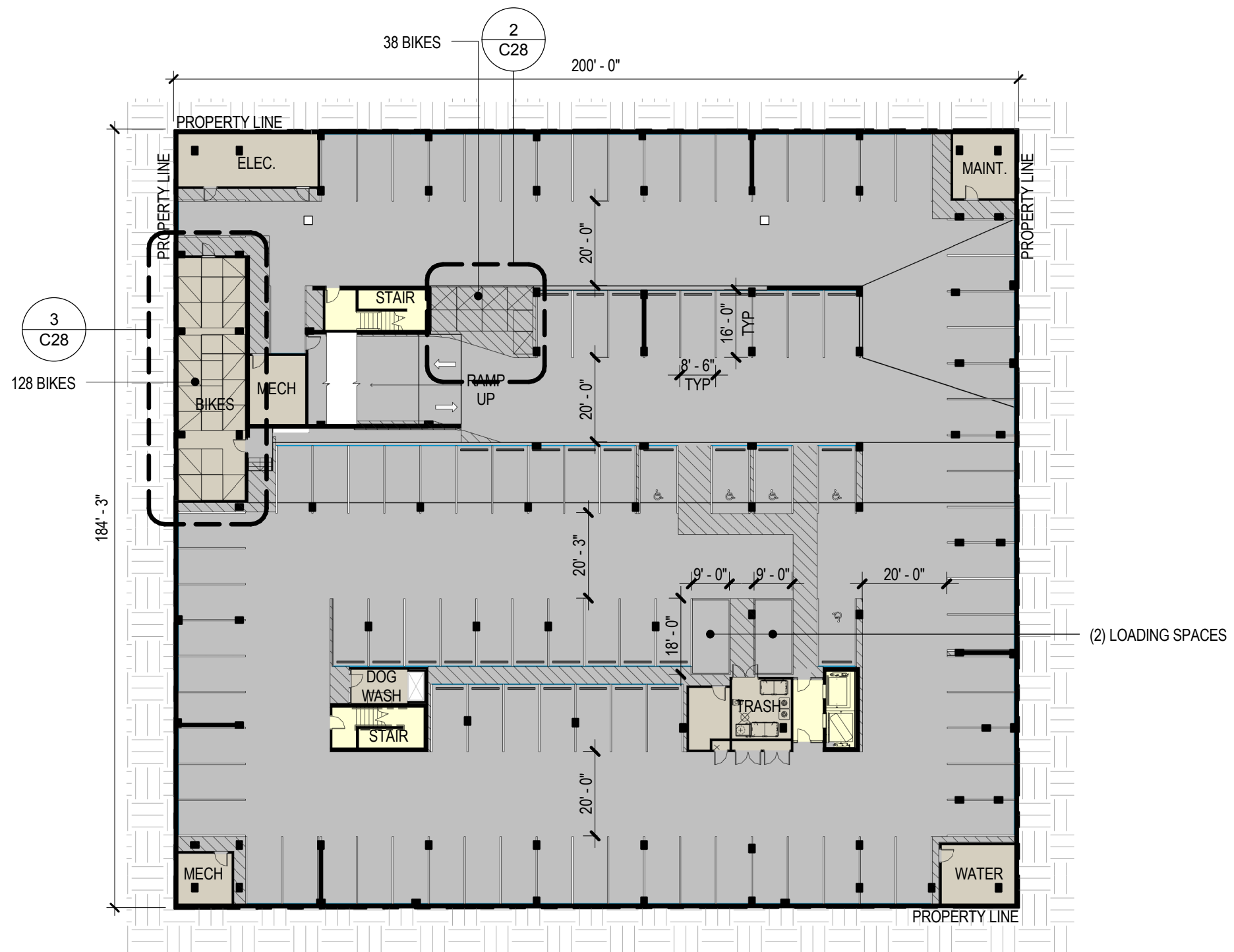



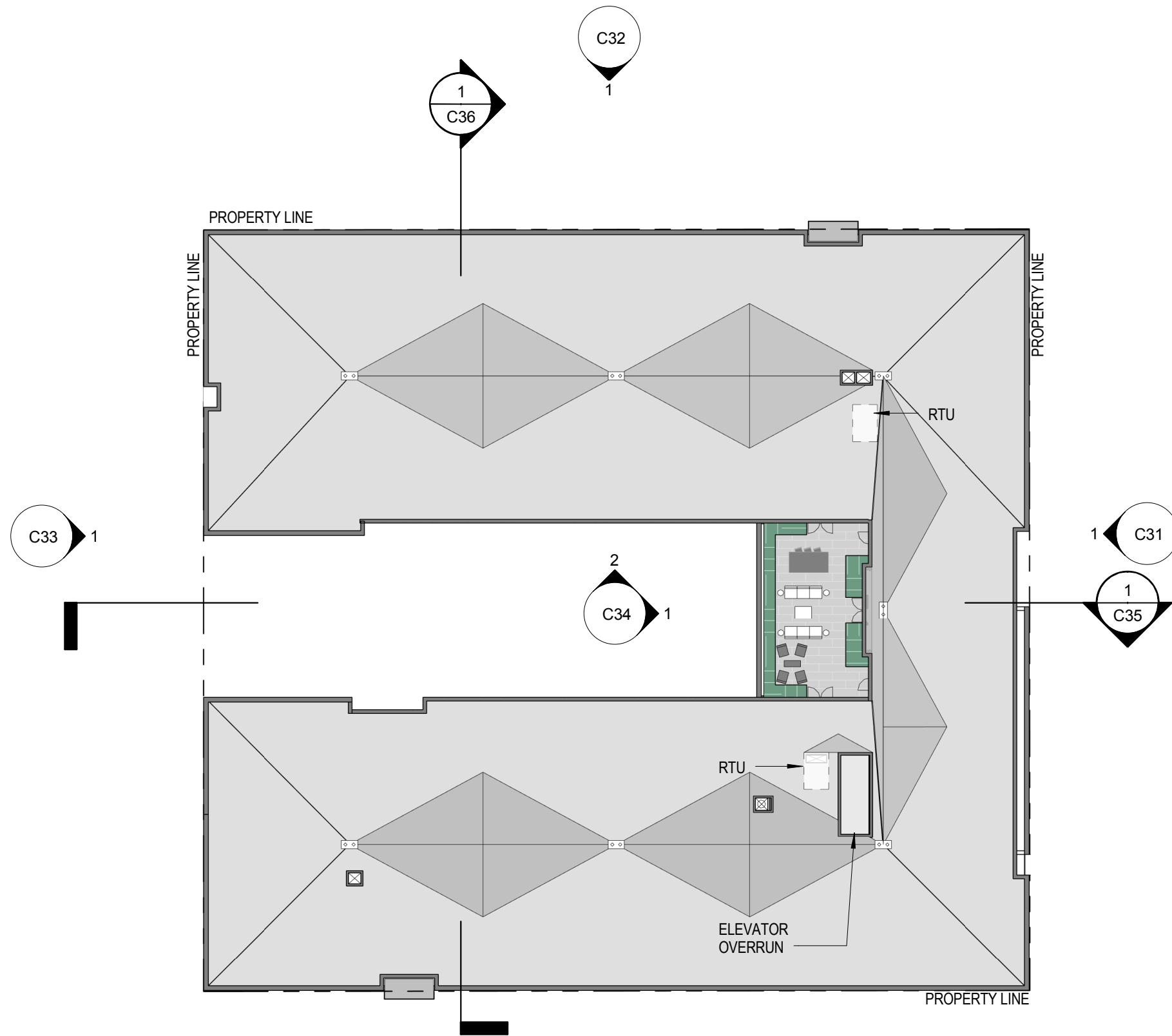

BICYCLE PARKING

PER CITY OF PORTLAND PLANNING AND ZONING CODE - CHAPTER 33.266, TABLE 266-6

LONG TERM BIKE PARKING REQUIREMENT:

RESIDENTIAL: 1.5 PER 1 UNIT ∴ 201 UNITS X 1.5 = 302 SPACES REQUIRED
 RETAIL SALES: 2, OR 1 PER 12,000 SF; (10,416 SF RETAIL AREA) ∴ 2 SPACES REQUIRED
 TOTAL: 304 - 356 PROVIDED

SHORT TERM BIKE PARKING REQUIREMENT:

RESIDENTIAL: 1 SPACE PER 20 UNITS ∴ 201 UNITS/20 = 11 SPACES REQUIRED
 RETAIL SALES: 2, OR 1 SPACE PER 5,000 SF; (10,416 SF RETAIL AREA) ∴ 3 SPACES REQUIRED
 TOTAL: 14 - 32 PROVIDED, SEE GROUND FLOOR PLAN

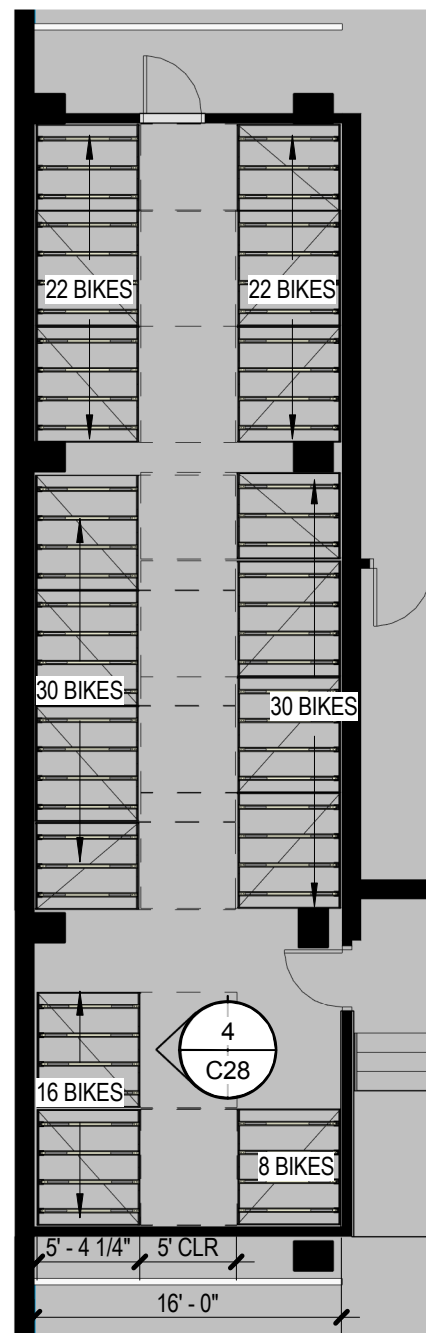

PARKING LEVEL BIKE ROOM ③
128 LONG-TERM BIKE PARKING SPACES

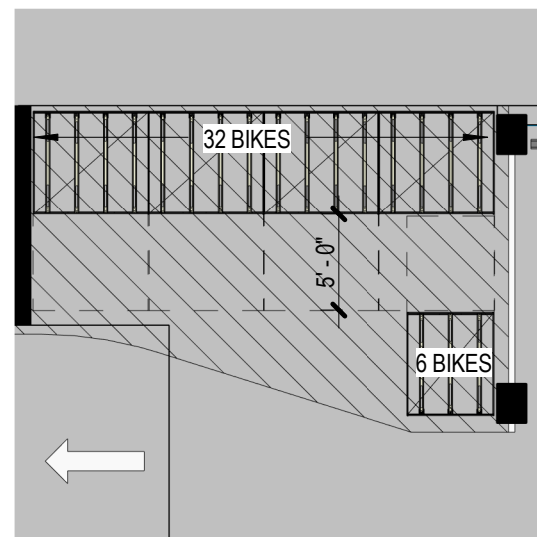

PARKING LEVEL BIKES ②
38 LONG TERM BIKE PARKING SPACES



GROUND FLOOR BIKE ROOM ①
190 LONG TERM BIKE PARKING SPACES

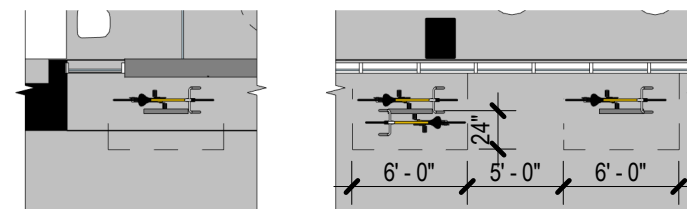

SHORT-TERM BIKE PARKING ⑤

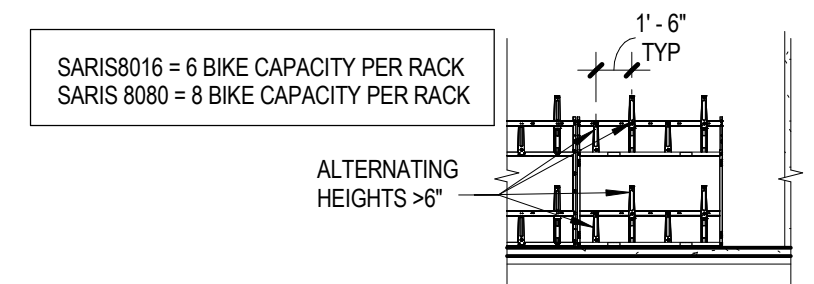

TYP BIKE RACK - FRONT ④

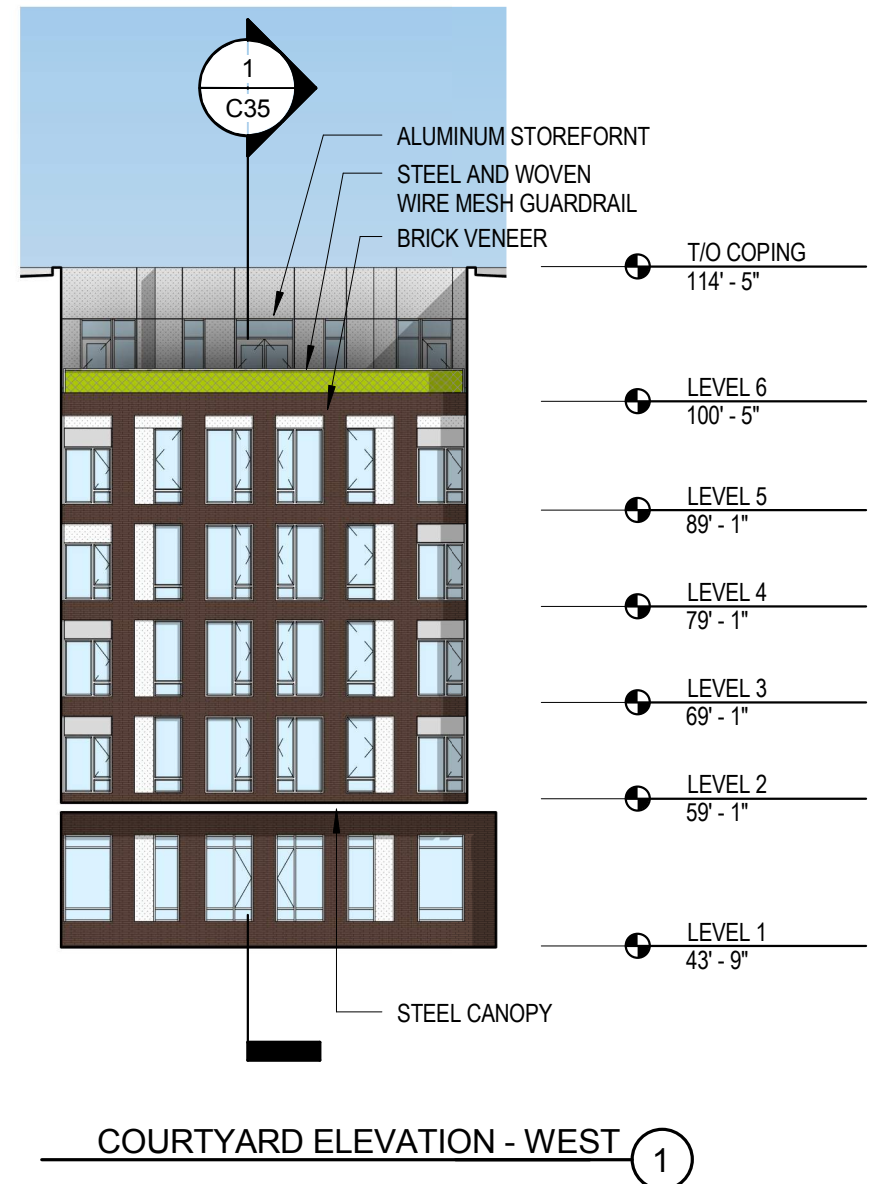
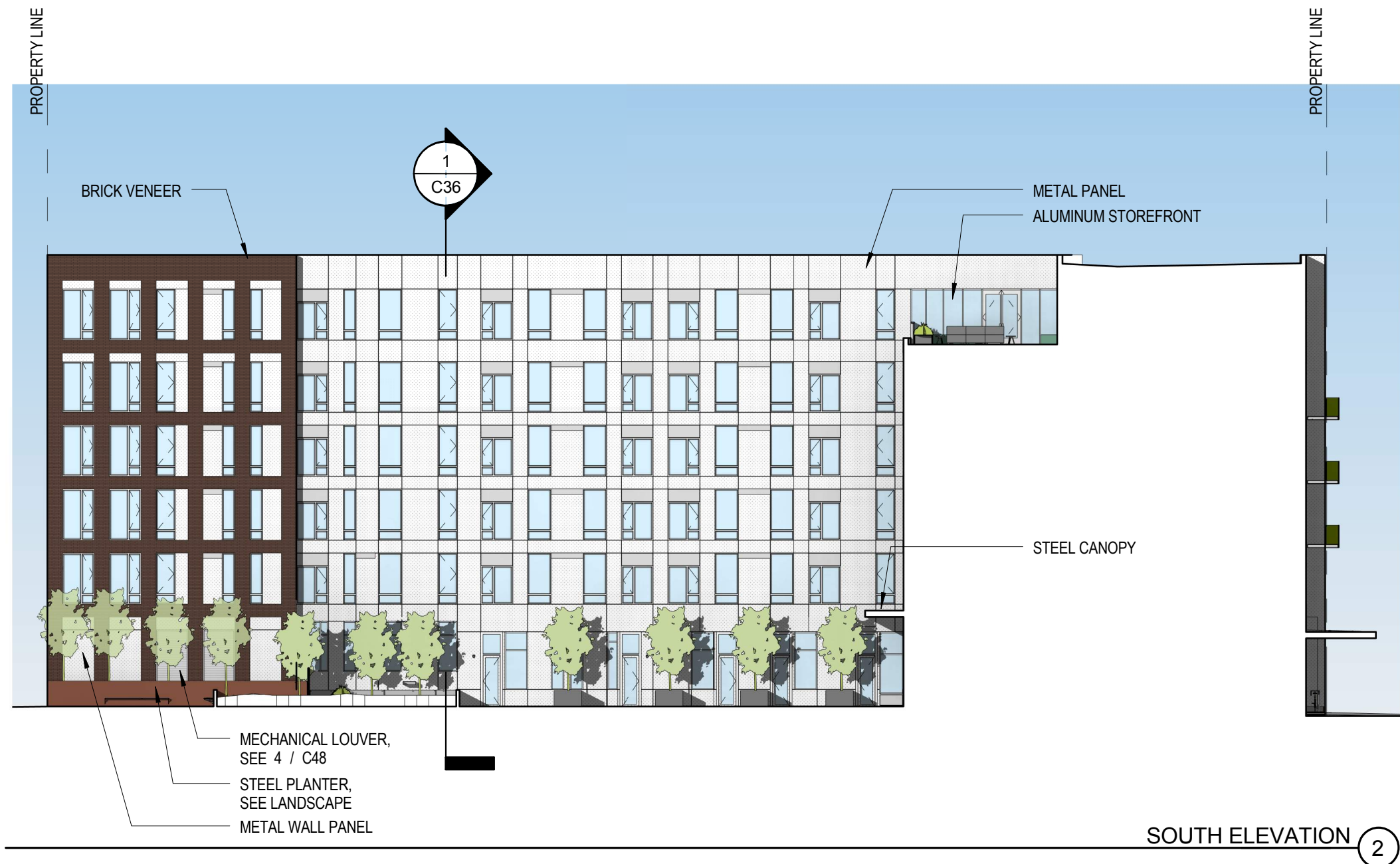

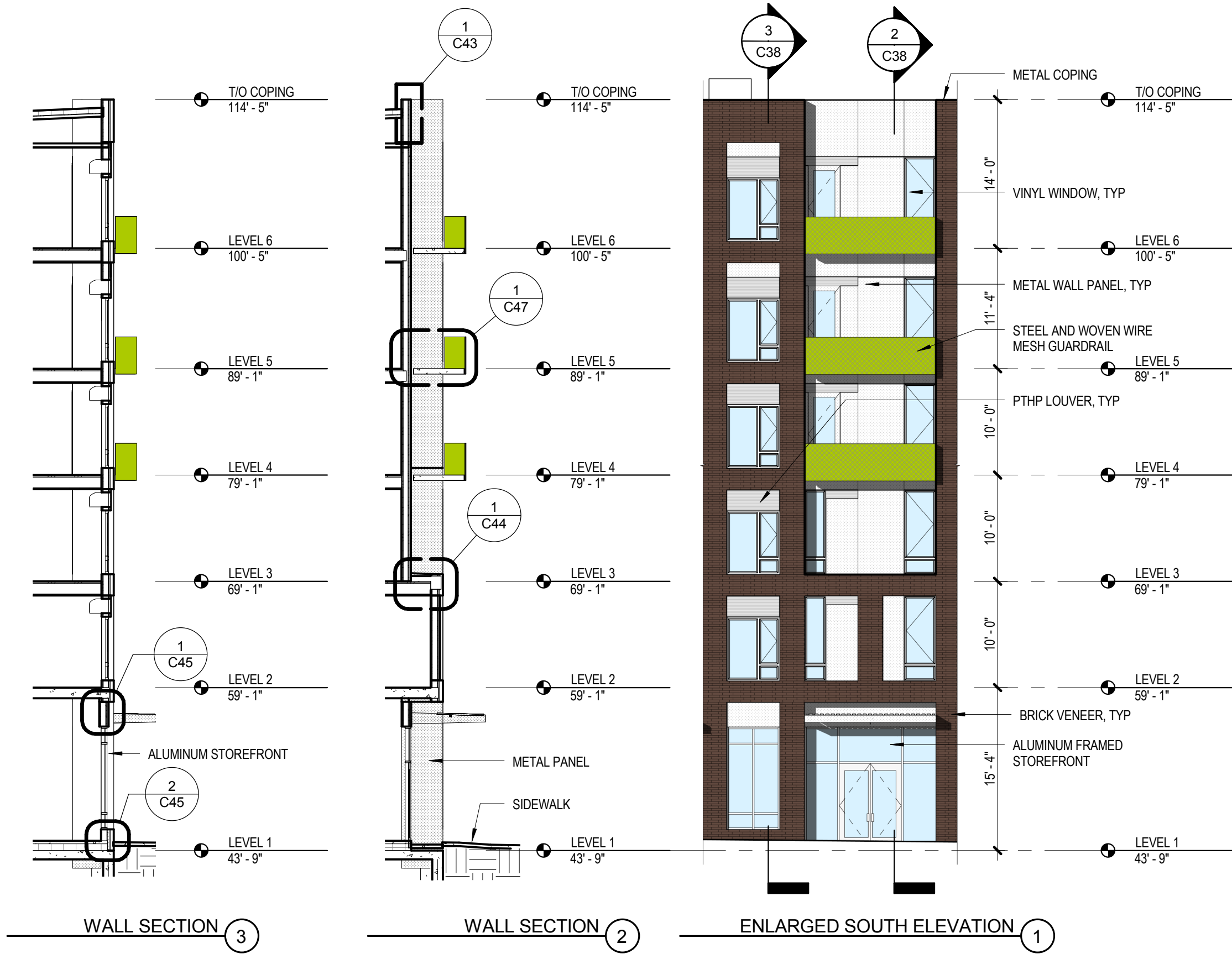

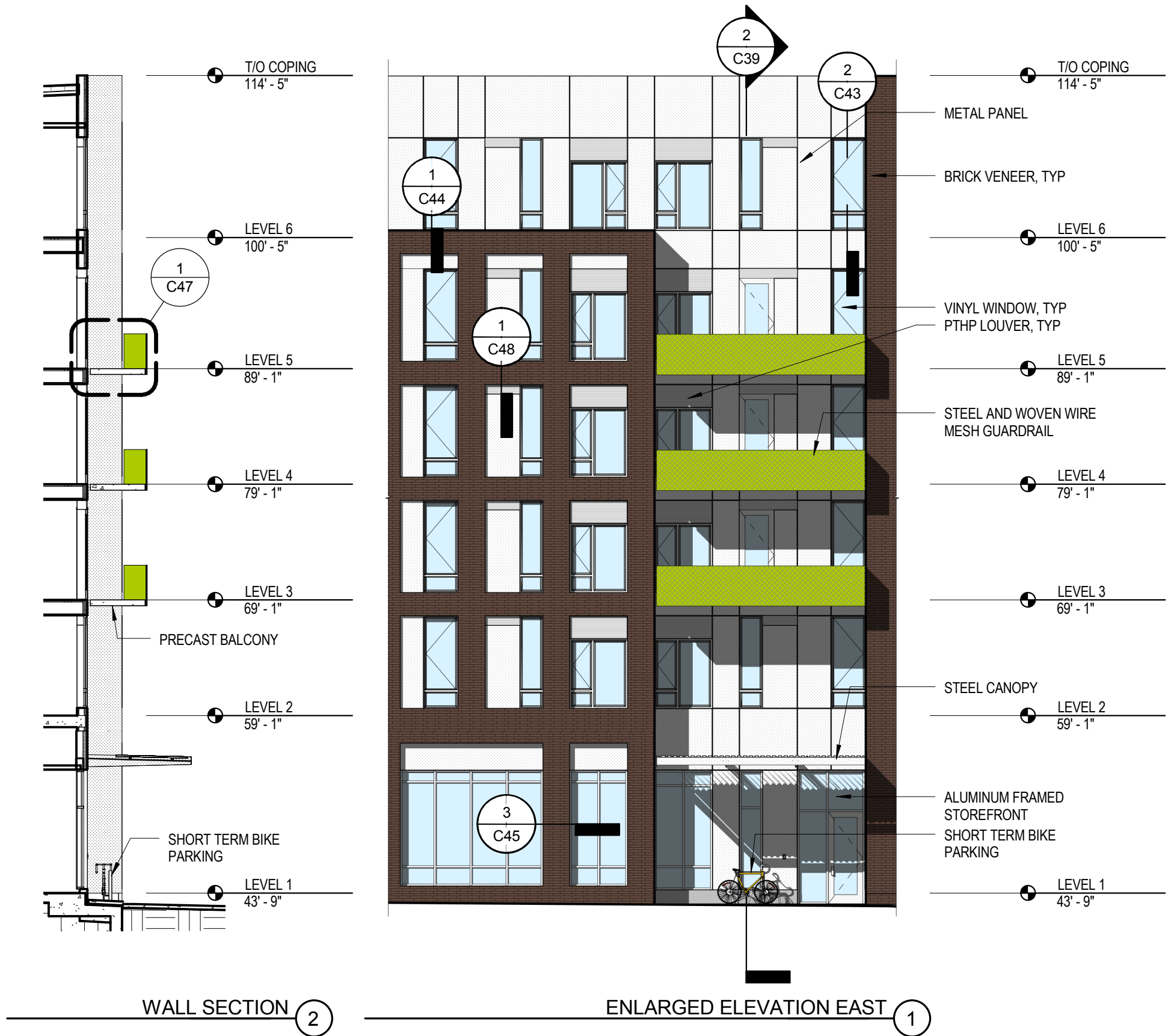

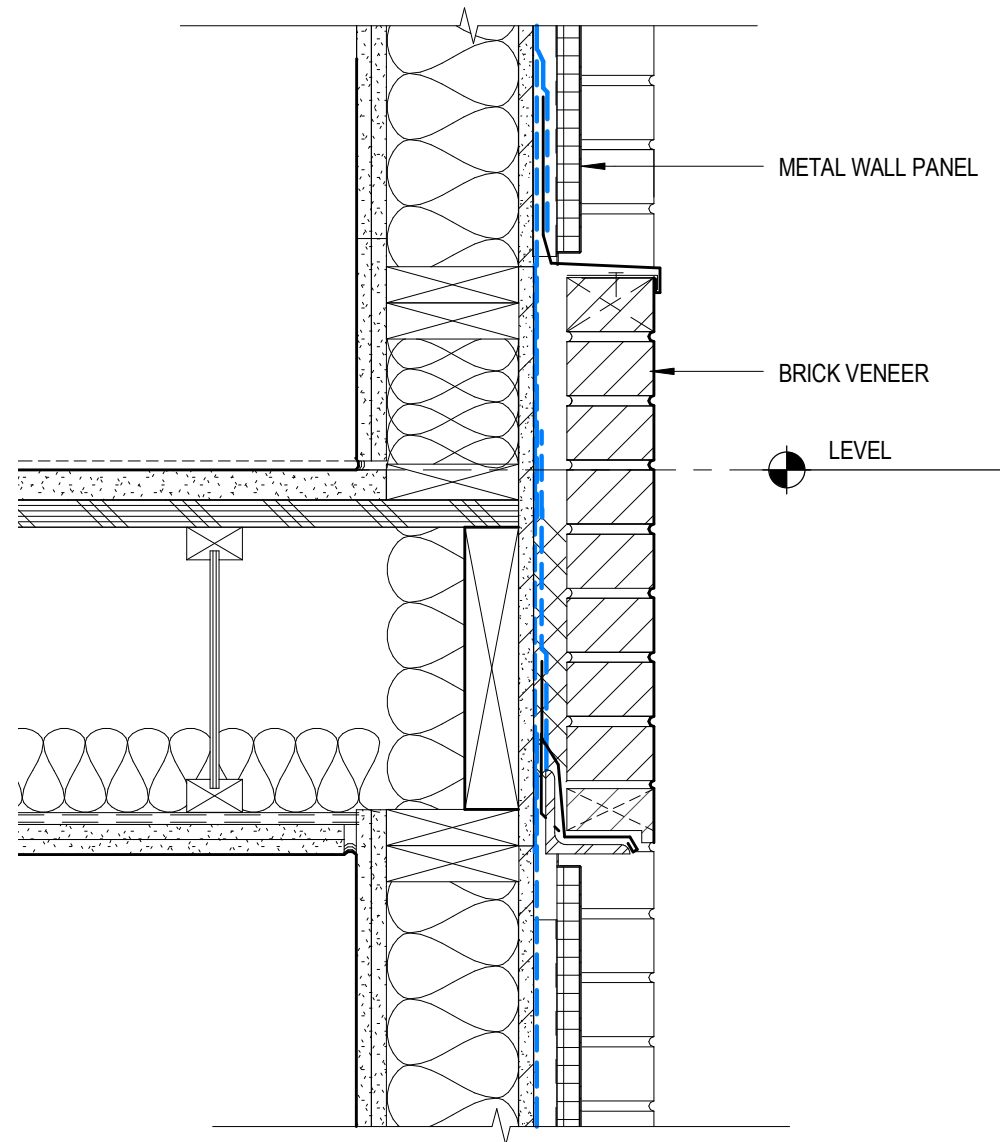

METAL PANEL HEAD/SILL AT BRICK ②
 1 1/2" = 1'-0"

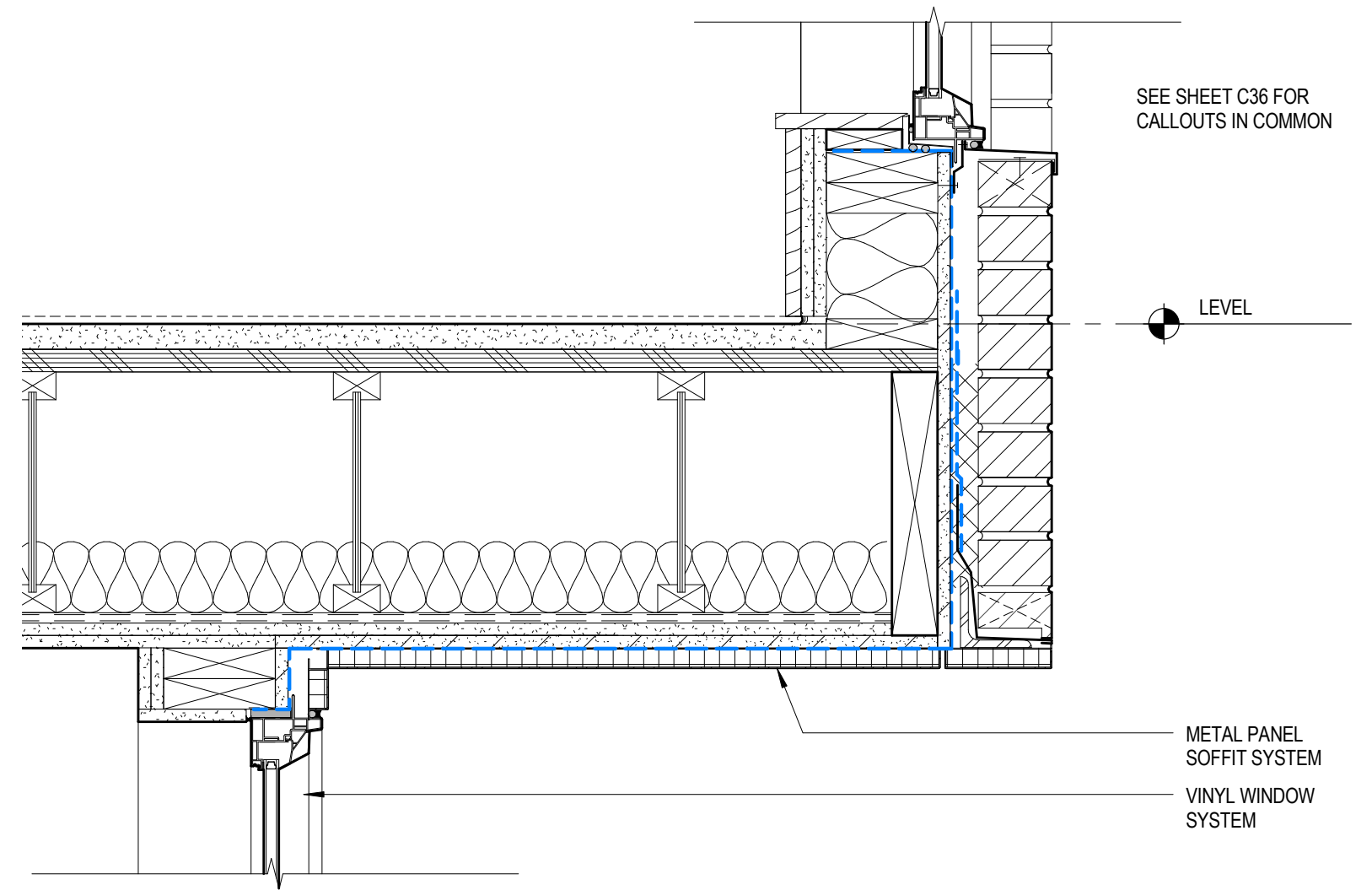

TYP SOFFIT AT BRICK ①
 1 1/2" = 1'-0"

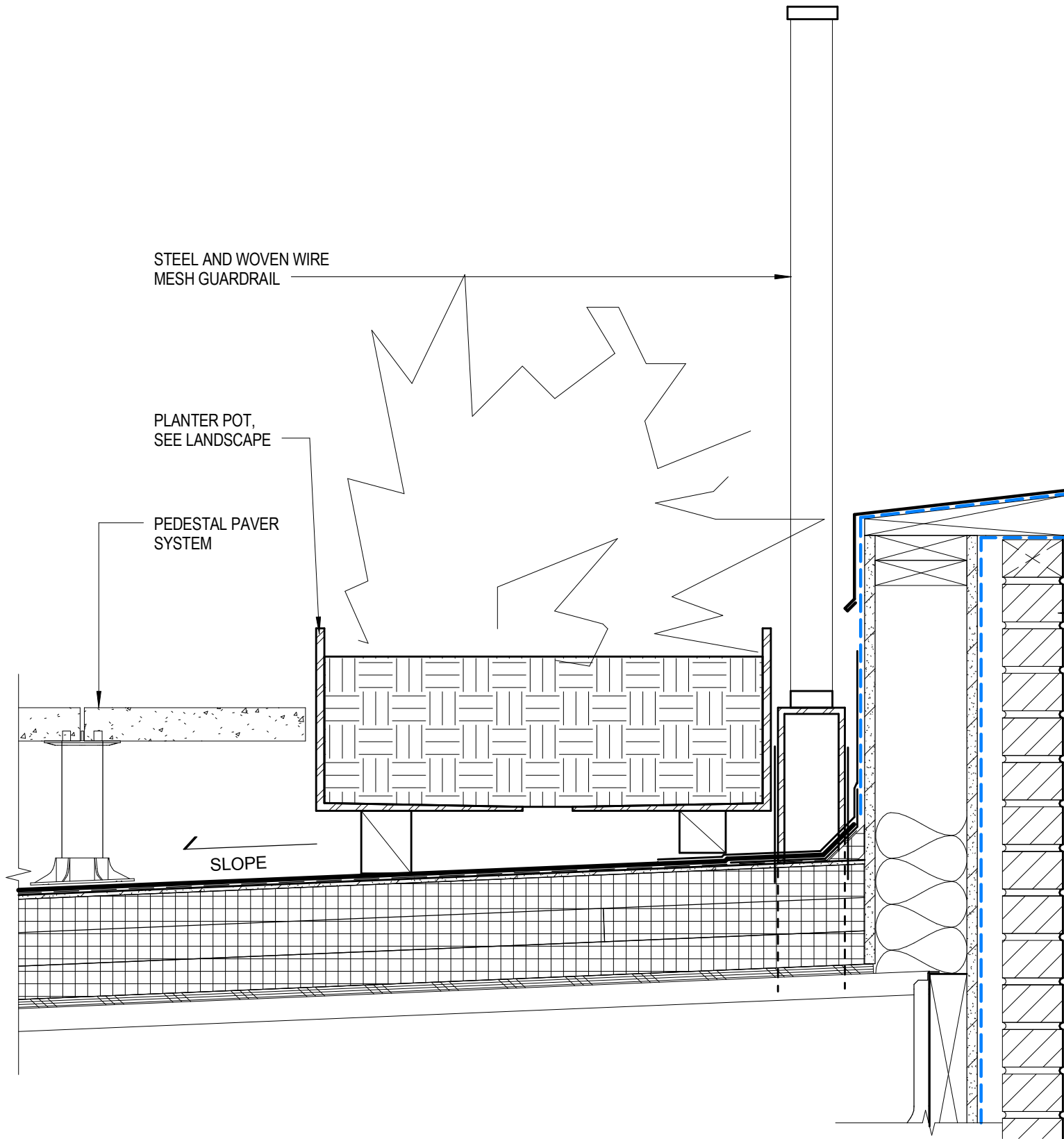

RAILING AT ROOF TERRACE ③
1 1/2" = 1'-0"

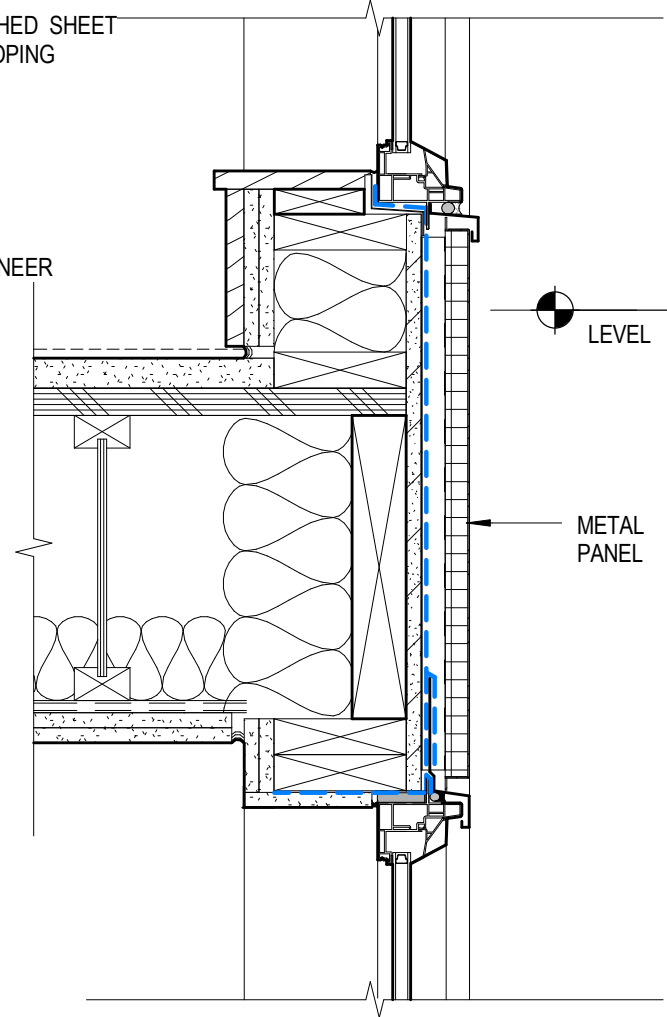

TYP HEAD & SILL AT METAL PANEL ②
1 1/2" = 1'-0"

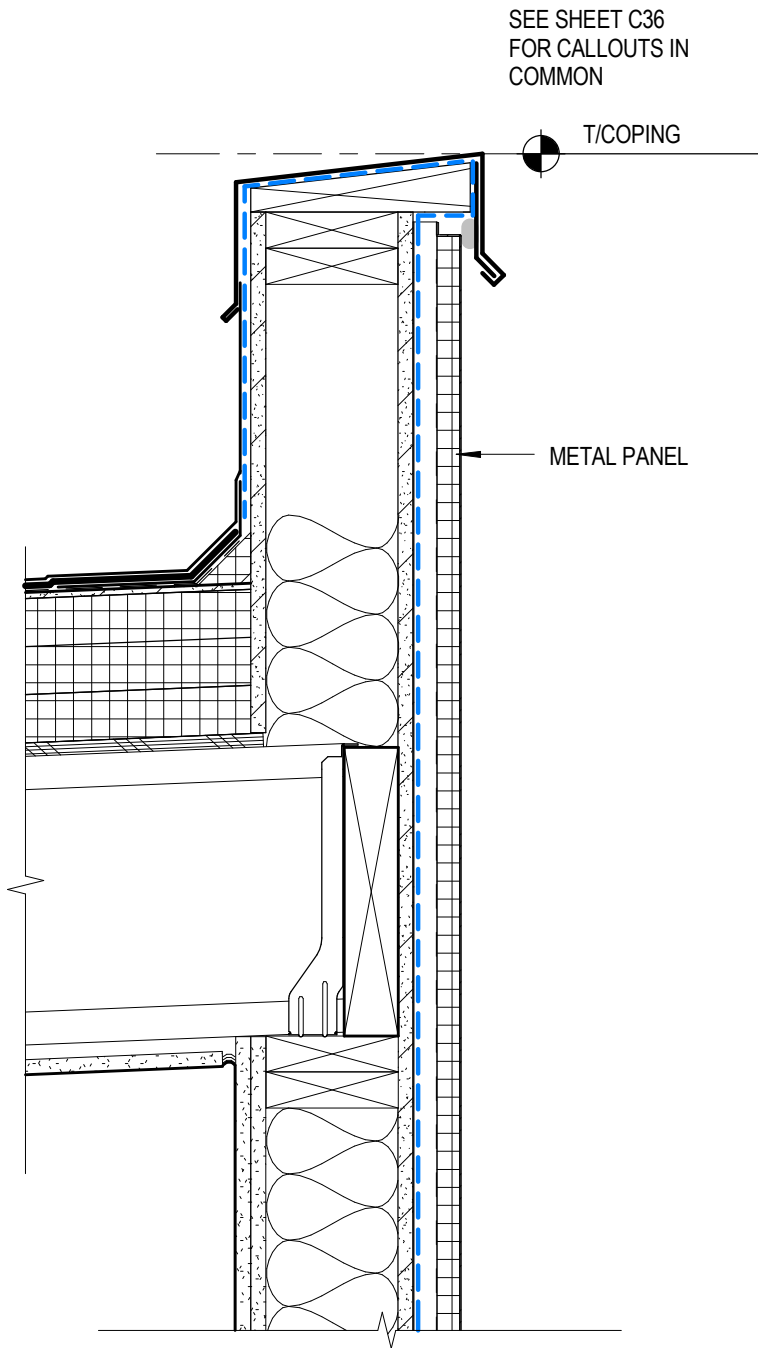

PARAPET AT METAL PANEL ①
1 1/2" = 1'-0"

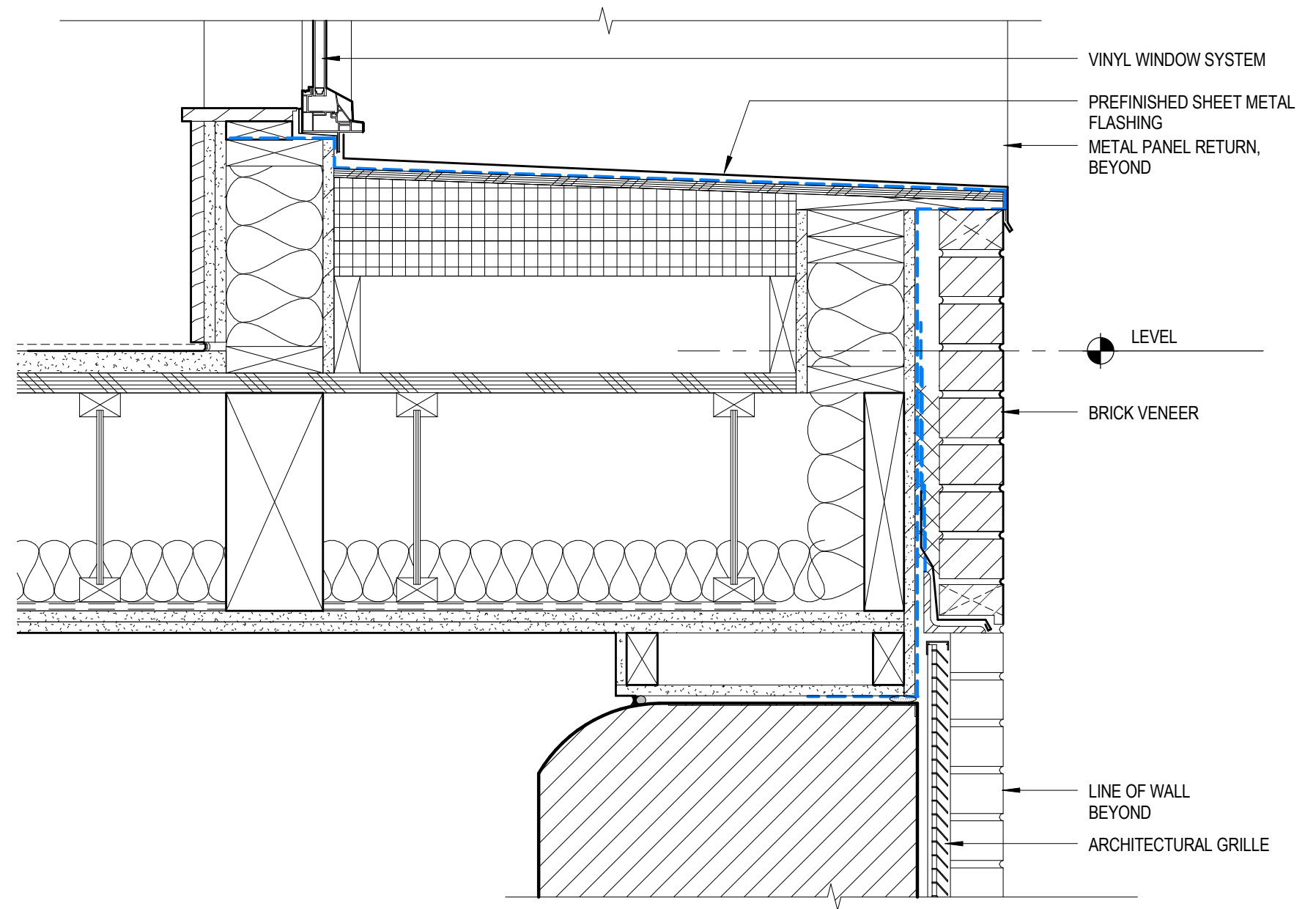

DR-SHELF AT SETBACK ①
 1 1/2" = 1'-0"

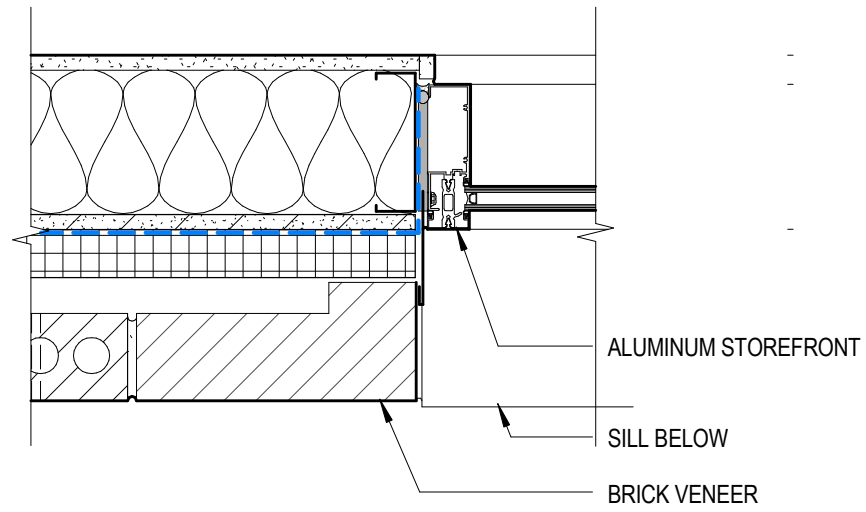

TYP STOREFRONT JAMB AT BRICK 3
 1 1/2" = 1'-0"

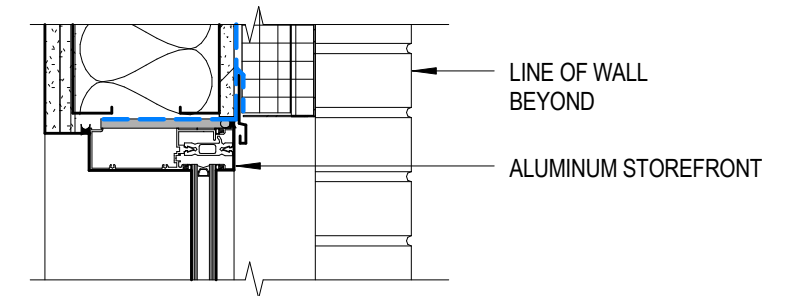
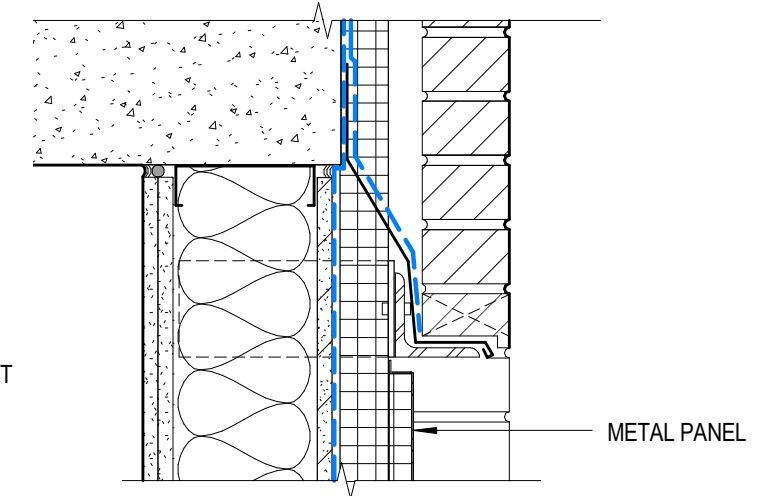

TYP STOREFRONT HEAD 1
 1 1/2" = 1'-0"

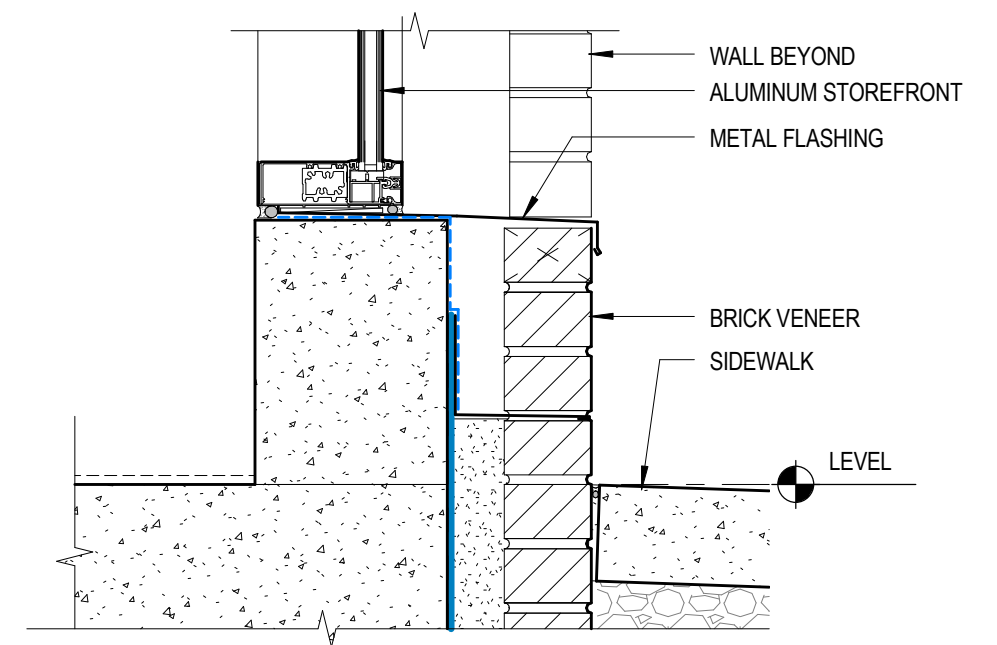

TYP STOREFRONT SILL 2
 1 1/2" = 1'-0"

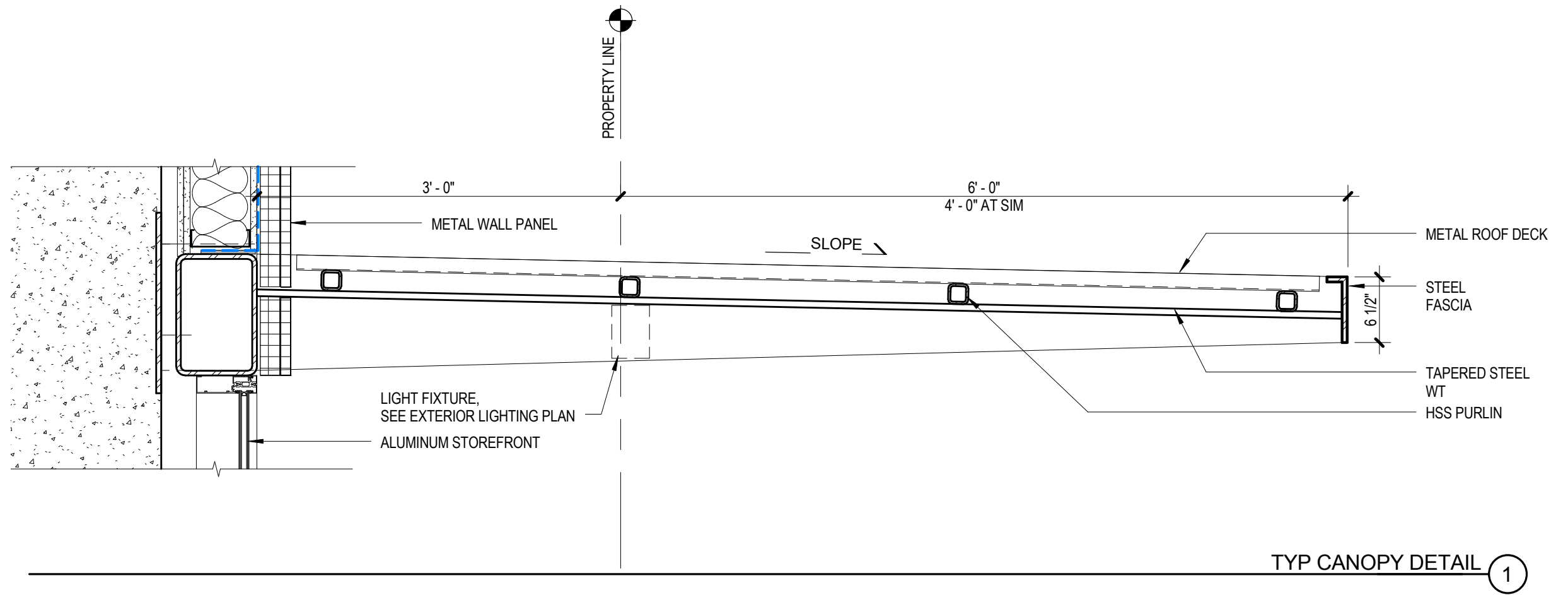

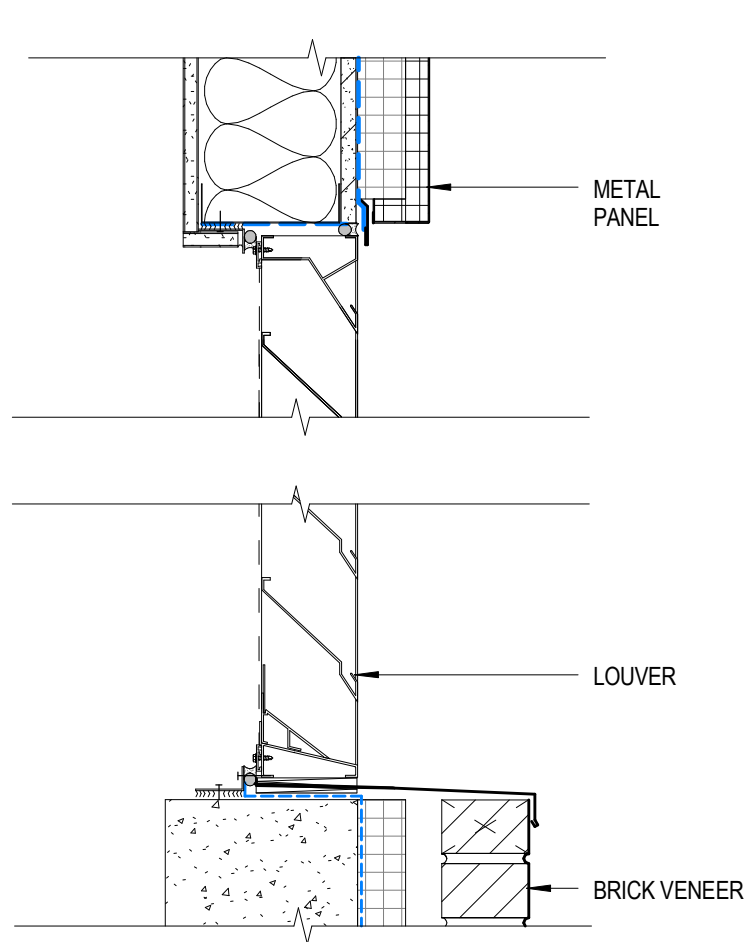

LOUVER HEAD/SILL ④

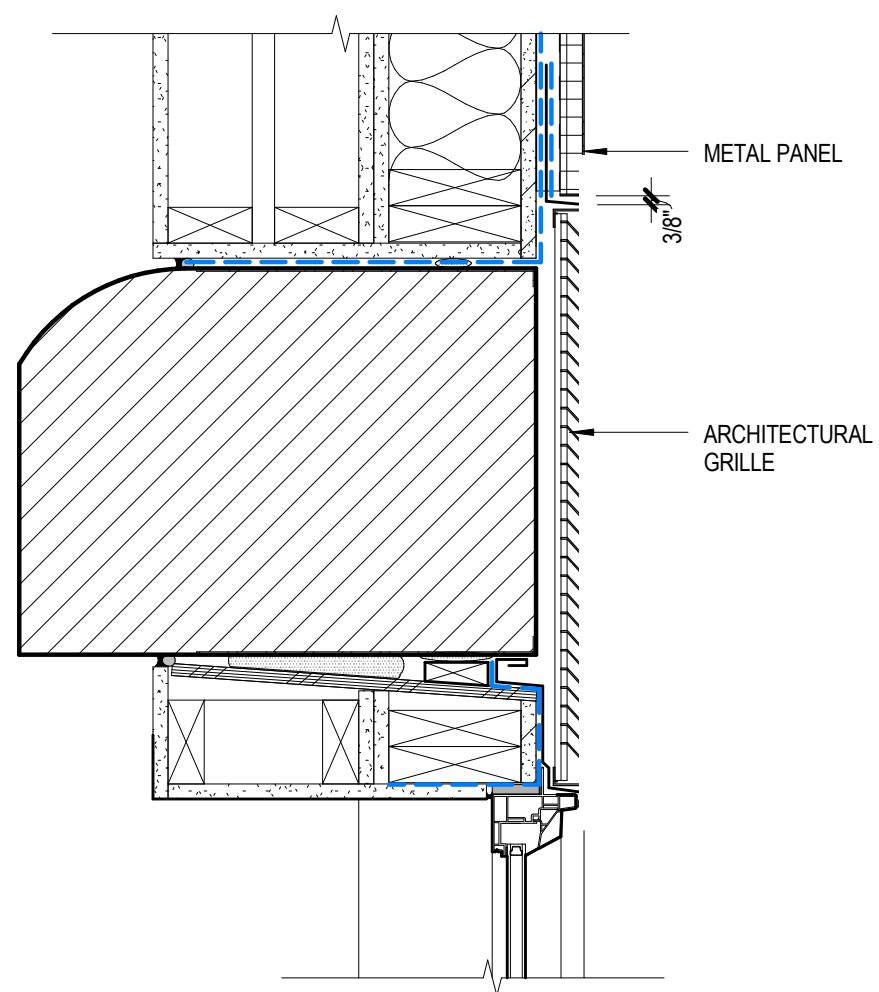

HEAD AT PTHP AT METAL PANEL ③

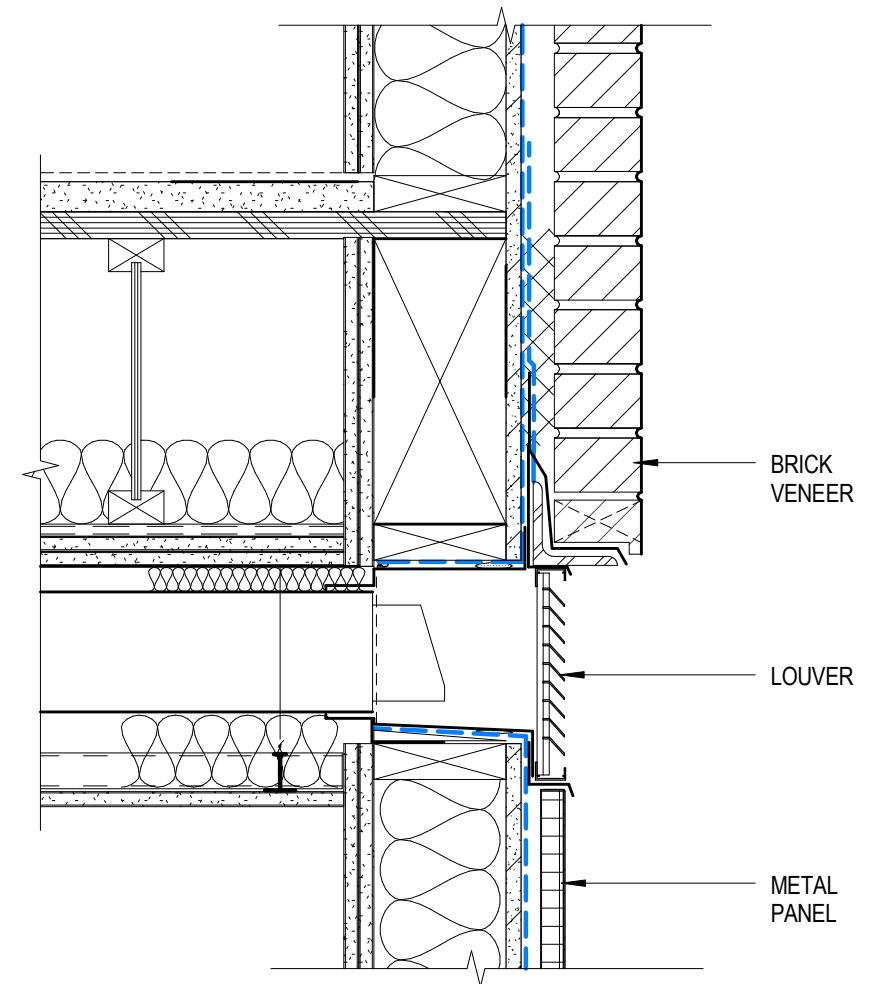

SECTION AT RESIDENTIAL LOUVER ①

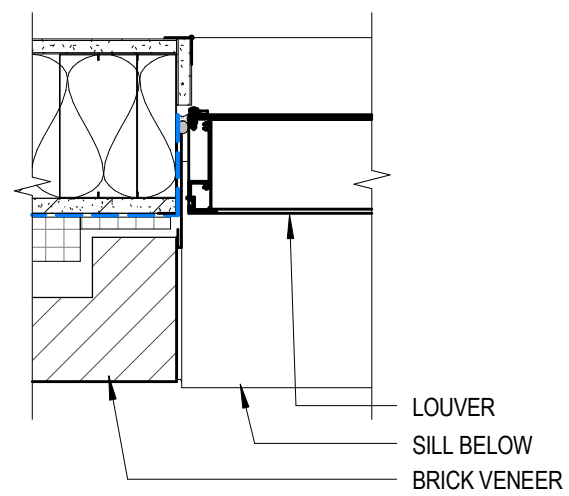

LOUVER JAMB ⑤

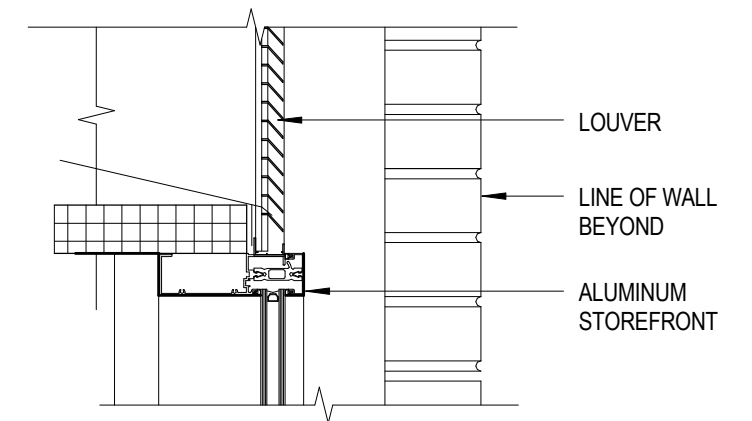

LOUVER IN STOREFRONT ②

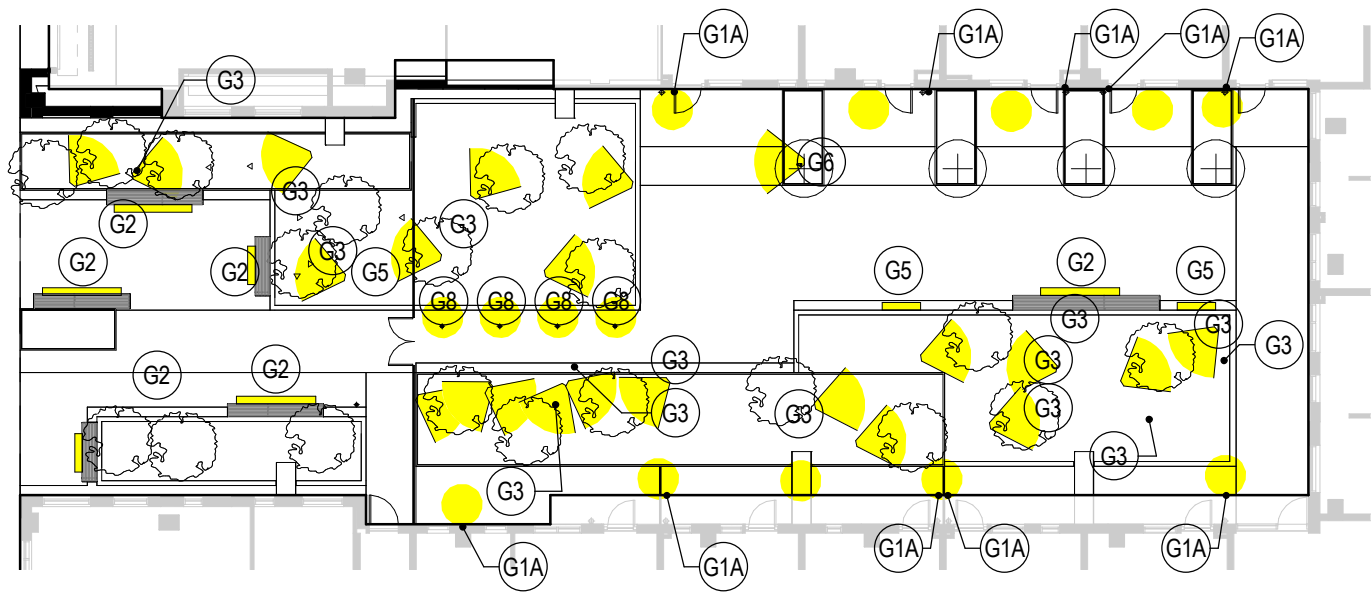

EXT LIGHTING PLAN - COURTYARD 2
1" = 20'-0"



EXT LIGHTING PLAN - PERIMETER 1
1" = 30'-0"

EXTERIOR LIGHTING SCHEDULE		
FIXTURE TYPE	DESCRIPTION	COUNT
G1A	SQUARE WALL MOUNT UP/DOWNLIGHT	10
G2	SURFACE LINEAR	6
G3	LANDSCAPE UPLIGHT	14
G5	RECESSED STEP LIGHT	3
G6	WALKWAY LIGHTING IN PLANTER	1
G8	INGROUND DISC	4
R1	RECESSED SQUARE DOWNLIGHT	26





CEDAR APARTMENTS

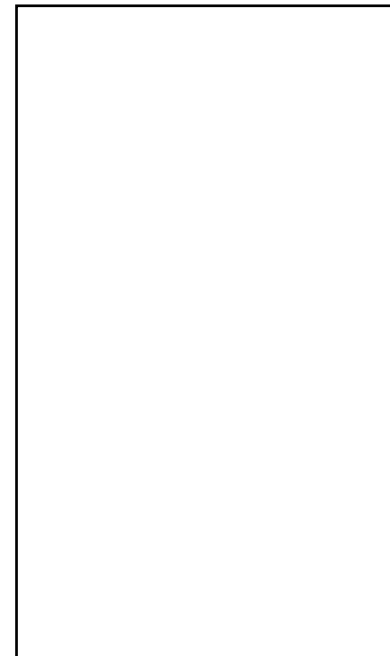

METAL PANEL - WHITE

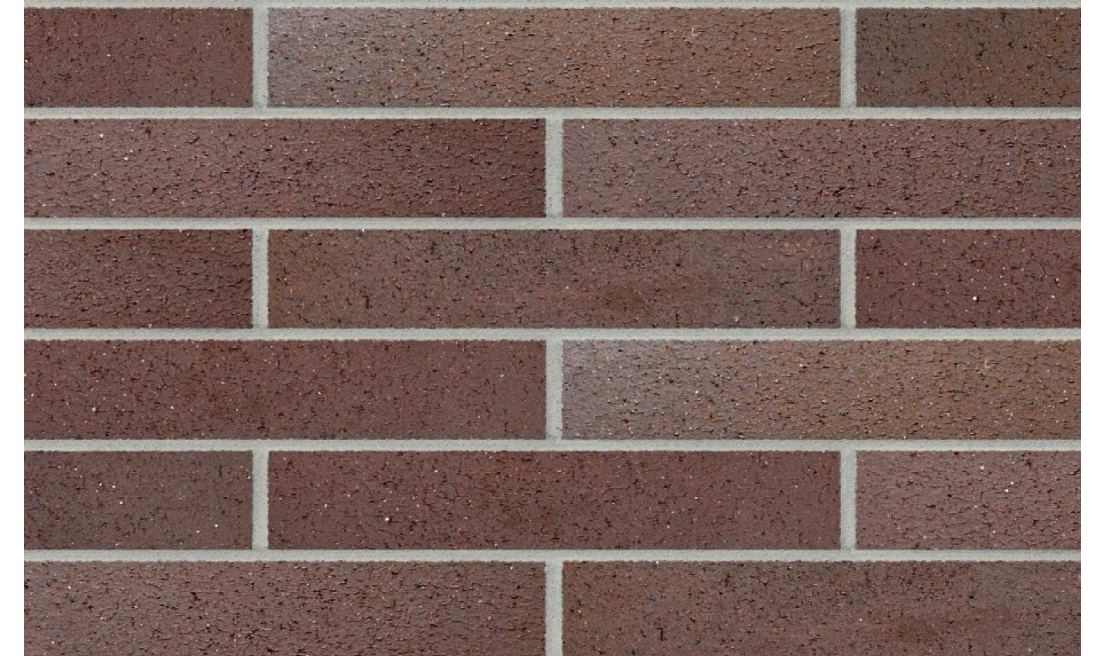

BRICK VENEER - IRONSTONE
NORMAN SIZE



STEEL AND WOVEN WIRE MESH
GUARDRAIL



FIBER CEMENT PANEL - WHITE

VPI VINYL WINDOW - WHITE

PTHP LOUVER - WHITE

ALUMINUM STOREFRONT - WHITE