





## TABLE OF CONTENTS

SE VIEW	C1
SE VIEW	C2
TABLE OF CONTENTS	C3
NE VIEW	C4
NW VIEW	C5
COURTYARD VIEWS	C6
VICINITY MAP	C7
BLOCK STUDY	C8
SITE AND CONTEXT PHOTOS	C9
PRECEDENTS	C10
MASSING DIAGRAMS	C11
GRADING PLAN	C12
SITE UTILITY PLAN	C13
LANDSCAPE SITE PLAN	C14
LANDSCAPE COURTYARD PLAN	C15
LANDSCAPE PLANTING PLAN	C16
LANDSCAPE ROOF TERRACE	C17
LANDSCAPE SECTION	C18
LANDSCAPE SECTION	C19
LANDSCAPE SECTION	C20
LANDSCAPE DETAILS	C21
FAR DIAGRAMS	C22
PARKING LEVEL	C23
GROUND FLOOR PLAN	C24
LEVELS 2-5	C25
LEVEL 6	C26
ROOF PLAN	C27
ENLARGED BIKE PARKING PLANS	C28
SOUTH ELEVATION	C29
EAST ELEVATION	C31
NORTH ELEVATION	C32
WEST ELEVATION	C33
COURTYARD ELEVATIONS	C34
BUILDING SECTION E/W	C35
BUILDING SECTION N/S	C36
ENLARGED ELEVATIONS	C37
ENLARGED ELEVATIONS	C38
ENLARGED ELEVATIONS	C39
ENLARGED ELEVATIONS	C40
EXTERIOR DETAILS	C41
EXTERIOR DETAILS	C42
EXTERIOR DETAILS	C43
EXTERIOR DETAILS	C44
EXTERIOR DETAILS	C45
CANOPY DETAILS	C46
EXTERIOR LIGHTING PLAN	C47
MATERIALS	C48









VIEW INTO COURTYARD



VIEW IN COURTYARD

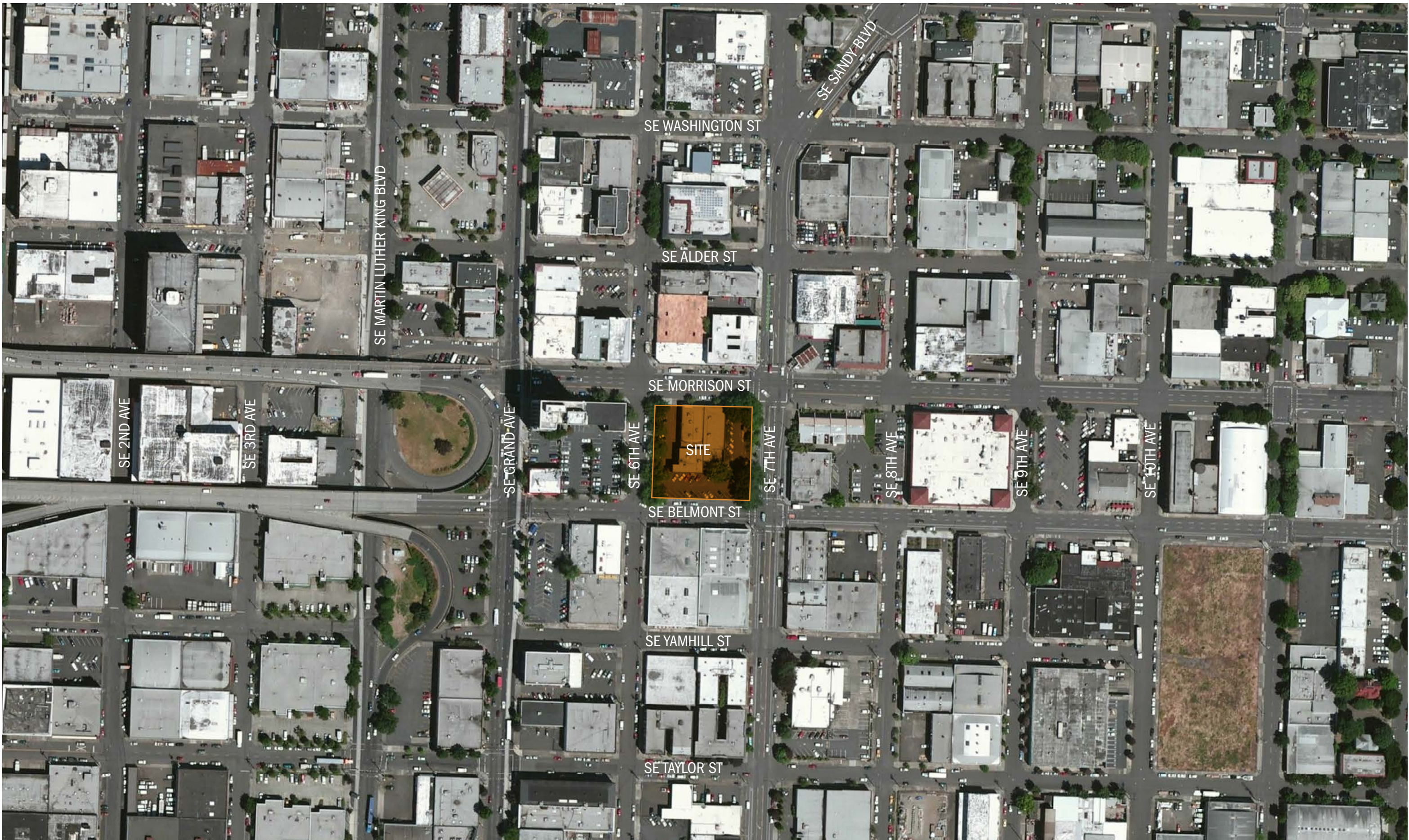

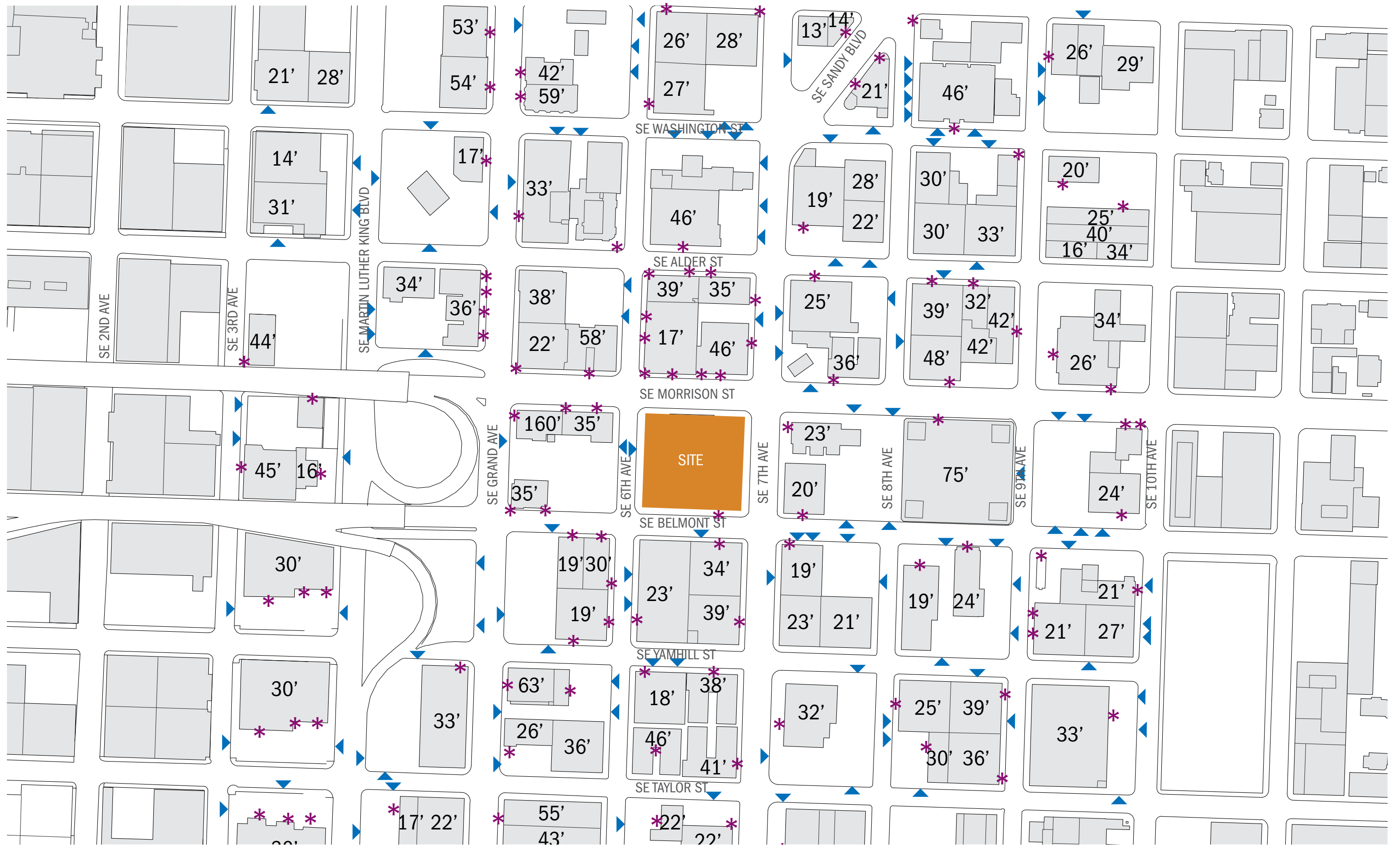

30' BUILDING FOOT PRINT AND HEIGHT ABOVE GRADE
 \* PEDESTRIAN ACCESS
▶ VEHICLE ACCESS
100'







APPROACH ON SE BELMONT ST



APPROACH ON SE MORRISON ST



CLIFFORD APARTMENTS

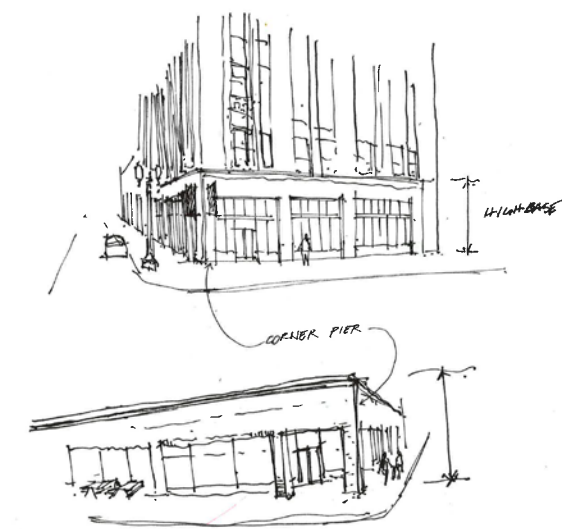



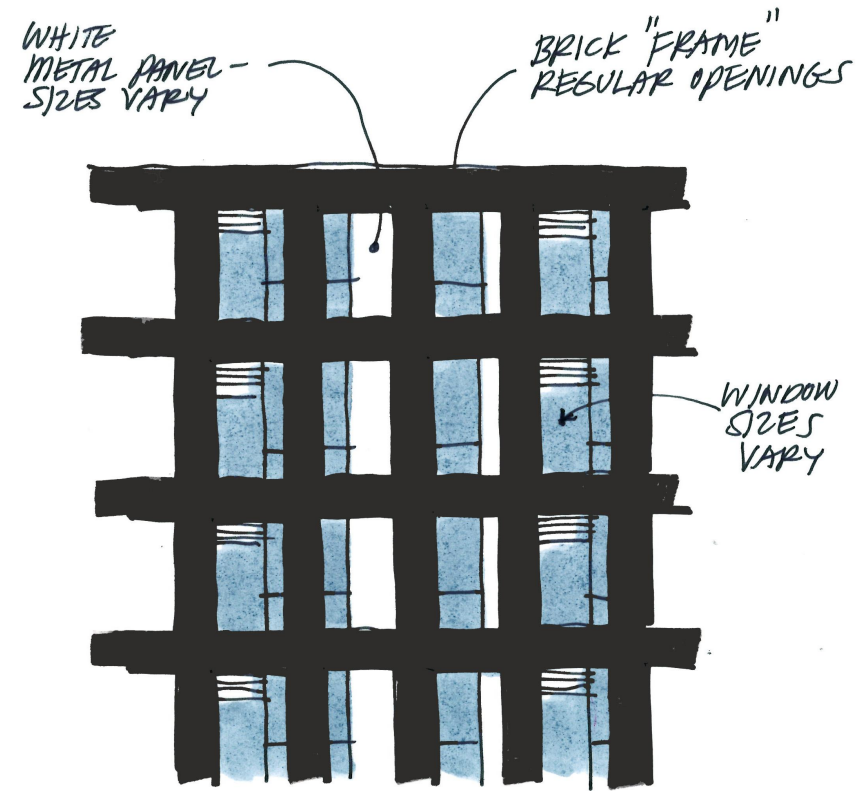

FACADE DIAGRAM

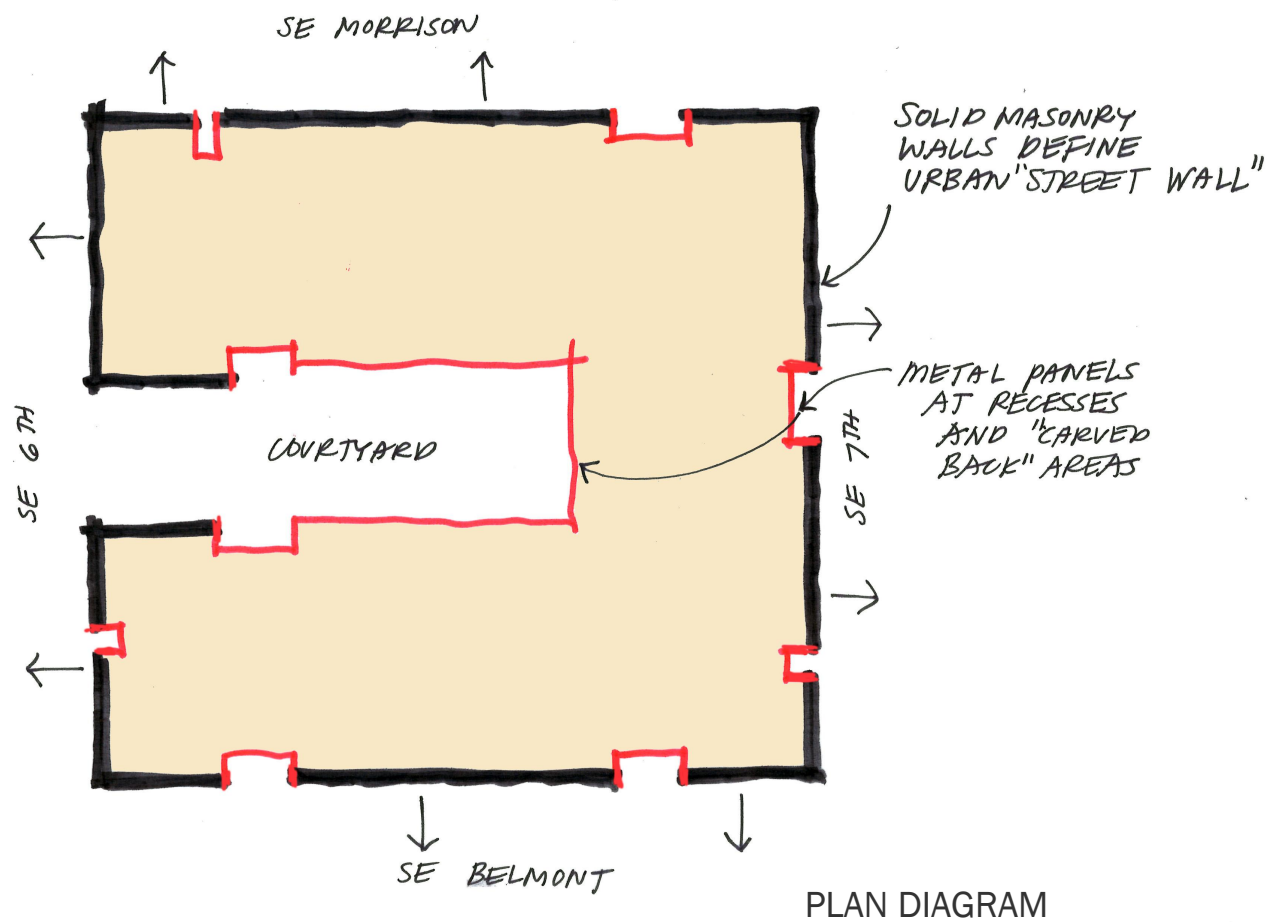

PLAN DIAGRAM

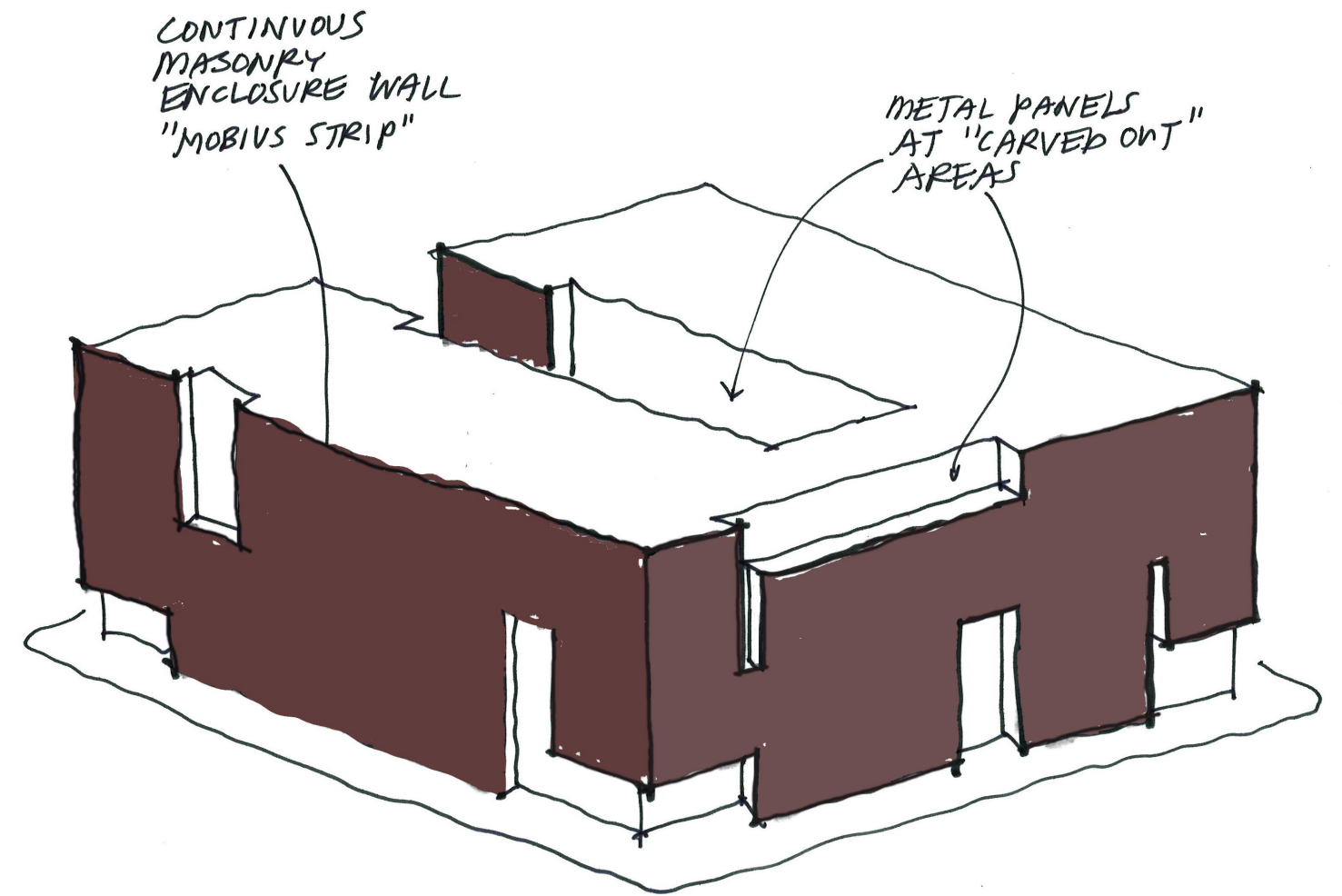

MASSING DIAGRAM

SHEET LEGEND	
TP XXX.XX	GRADE AT TOP OF PAVEMENT
TC XXX.XX	GRADE AT TOP OF CURB
G XXX.XX	GRADE AT GUTTER
(E)	EXISTING
X.X%	SLOPE ARROW
- - - 286 - - -	EXISTING CONTOUR

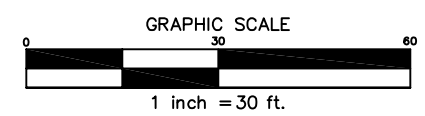
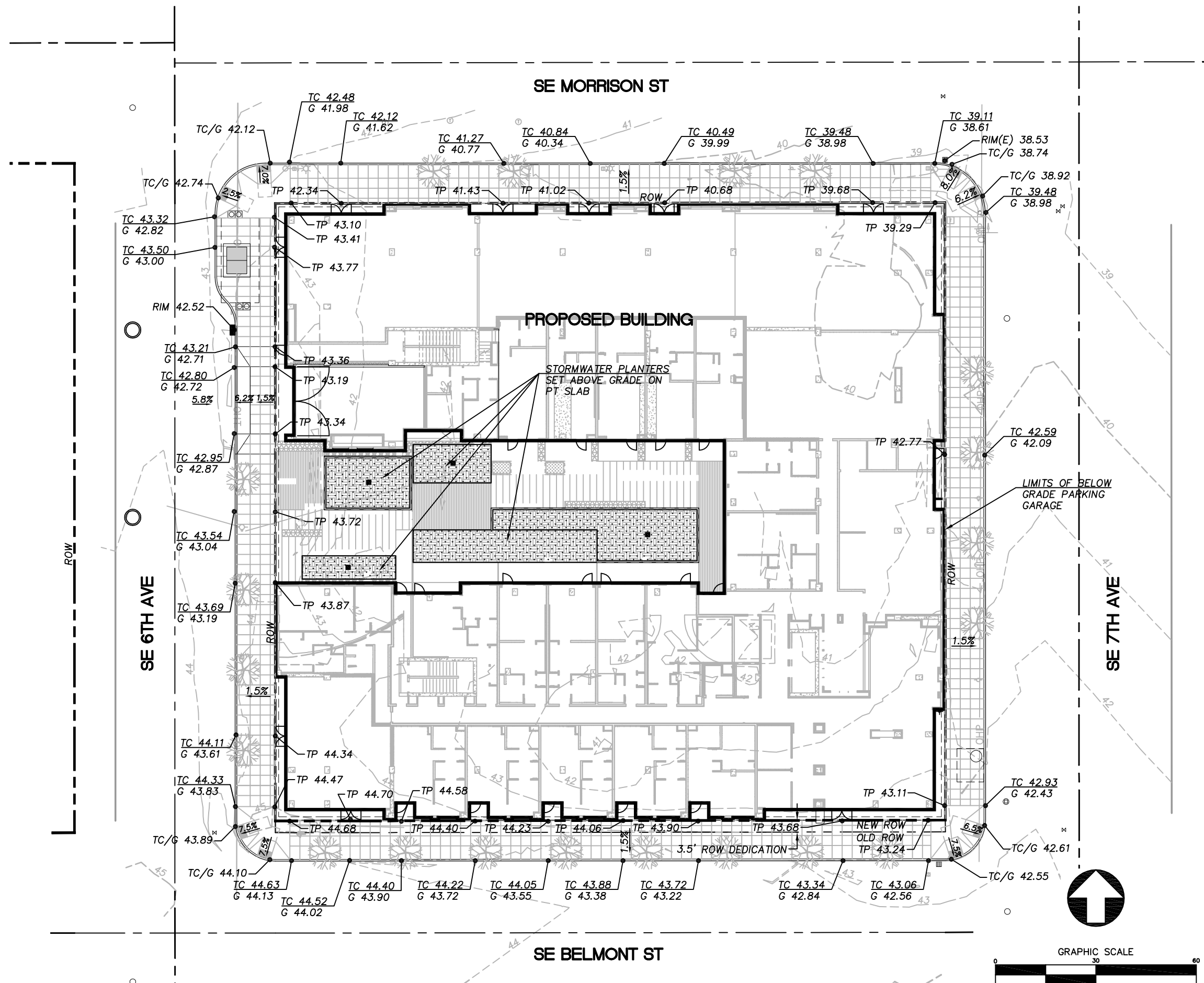

# STORMWATER NARRATIVE

## PRIVATE SITE:

**WATER QUALITY**  
WATER QUALITY CONTROL IS MET WITH FLOW-THROUGH PLANTERS. THE PLANTERS ARE SIZED TO TREAT ALL ROOF AREA. A SPECIAL CIRCUMSTANCE WILL BE REQUESTED TO MITIGATE RUNOFF FROM THE COURTYARD

**WATER QUANTITY**  
WATER QUANTITY CONTROL IS ALSO MET WITH FLOW-THROUGH PLANTERS WHICH ARE SIZED TO SLOW DOWN THE PEAK FLOW RATE FOR THE 25 YR STORM EVENT.

**DISPOSAL**  
INFILTRATION IS NOT POSSIBLE DUE TO BELOW GRADE PARKING GARAGE COVERING ENTIRE SITE. ALL RUNOFF FROM THE SITE WILL BE PIPED TO THE 66" COMBINED SEWER PIPE IN SE 7TH AVENUE. THE PROJECT WILL FALL UNDER CATEGORY 4 OF THE STORMWATER DISPOSAL HIERARCHY.

**PUBLIC STREET IMPROVEMENTS:**  
STORMWATER MANAGEMENT IS NOT REQUIRED FOR THE IMPROVEMENTS TO THE PUBLIC SIDEWALKS IN THE PUBLIC RIGHT OF WAY. THE EXISTING STORMWATER DRAINAGE FOR THE RIGHT OF WAY WILL BE PROTECTED DURING CONSTRUCTION.

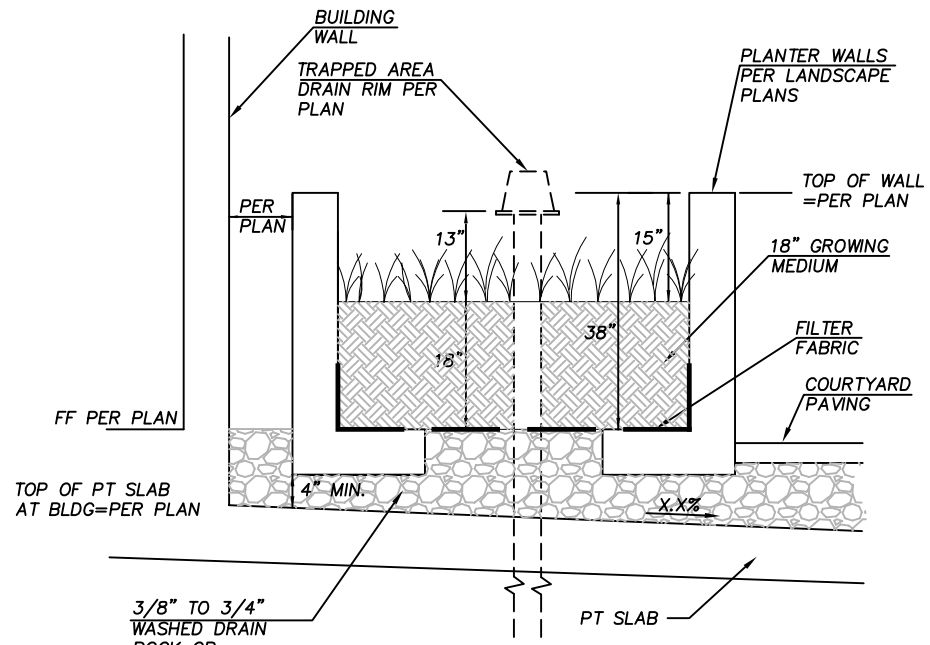
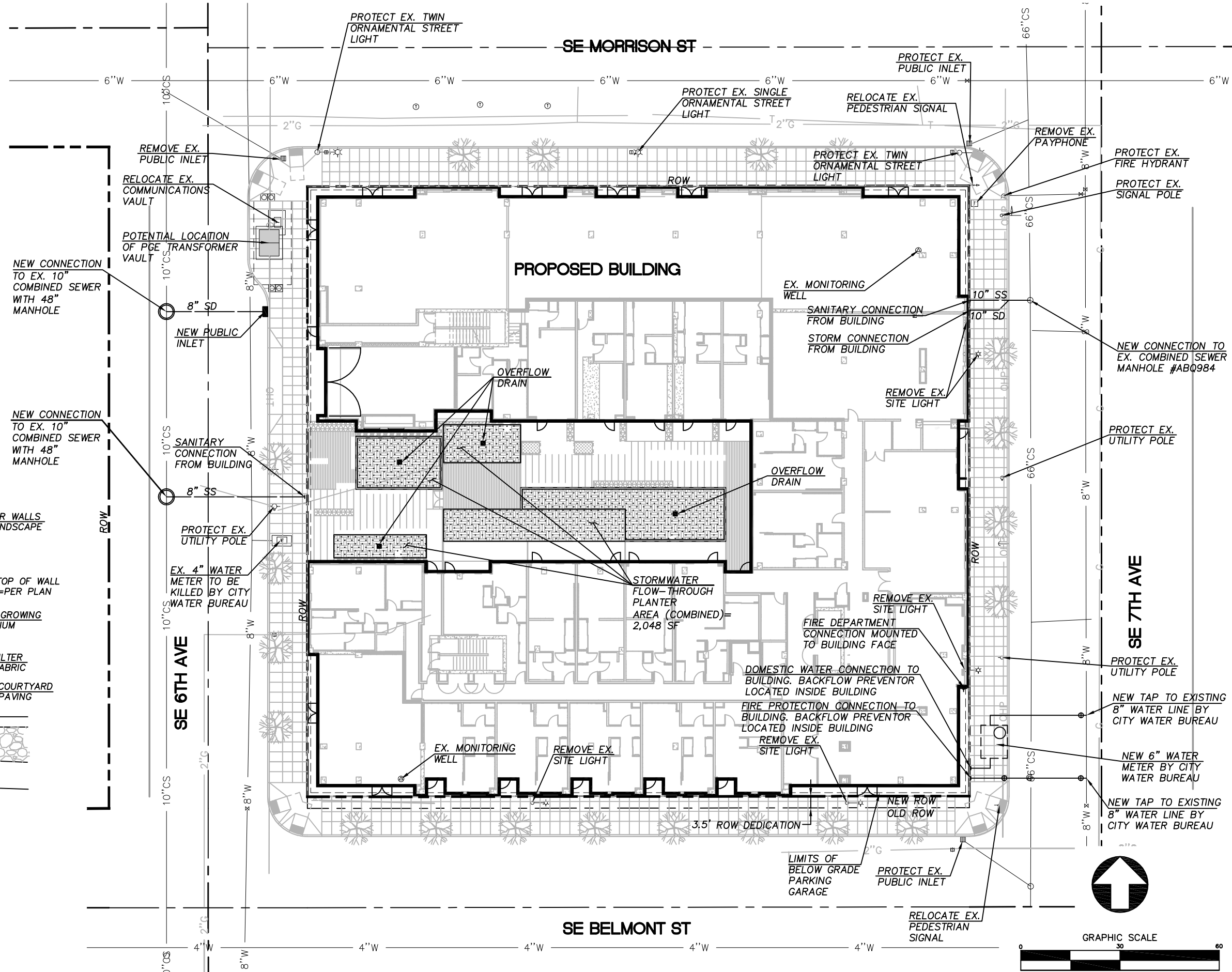

- NOTES:**
1. PLANTING PER LANDSCAPING PLANS.
  2. GROWING MEDIUM PER SPECIFICATIONS.

**1 STORMWATER FLOW-THROUGH PLANTER**  
NTS

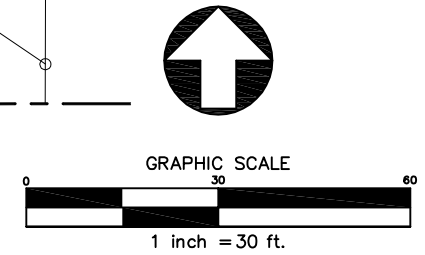

STREET TREES W/O POWER LINE

STREET TREES WITH POWER LINE



PYRMIDAL EUROPEAN HORNBEAM



GINKO SARATOGA



FOREST GREEN OAK

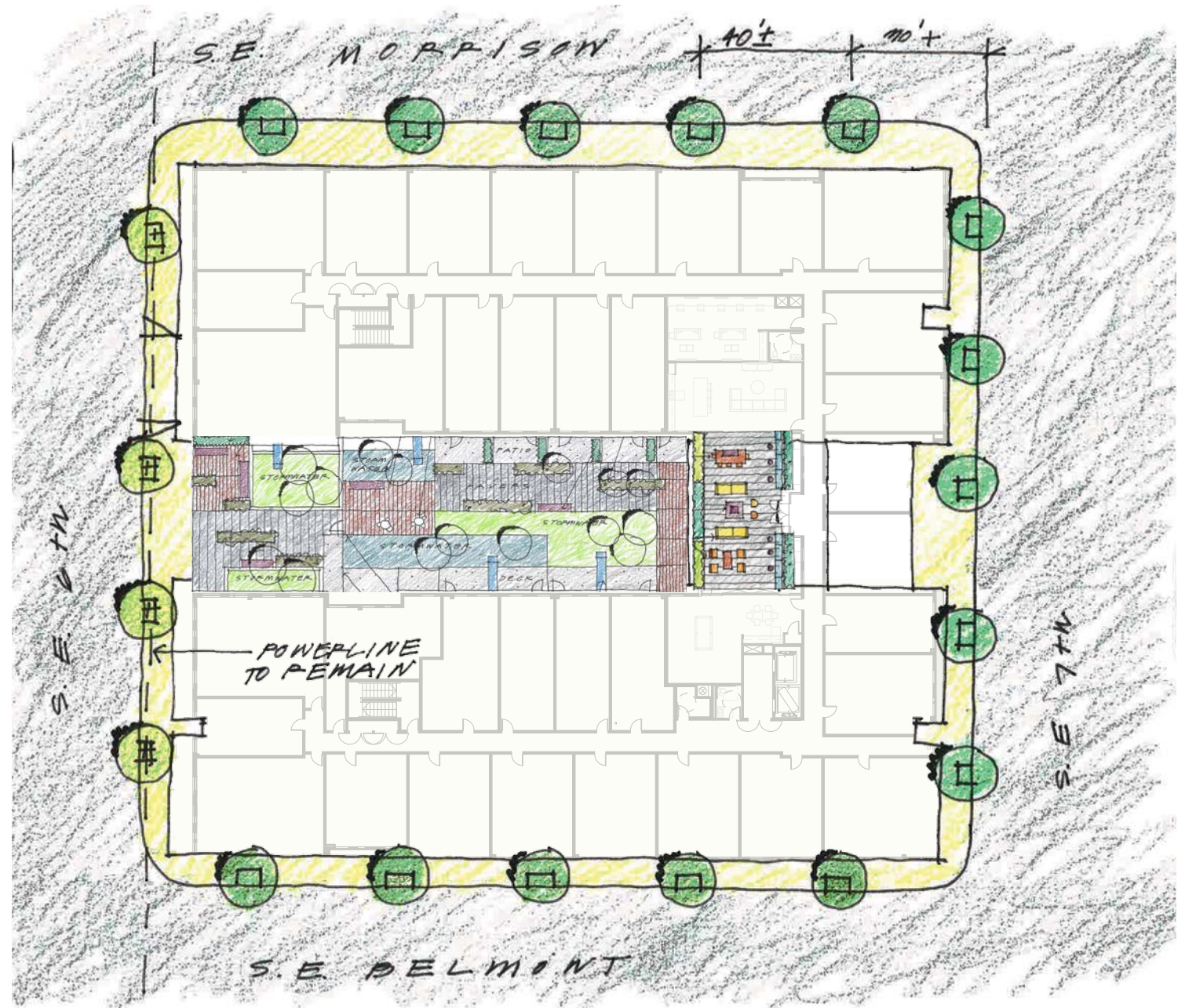

LANDSCAPE MATERIALS



CONCRETE PAVERS/WOOD BENCH



CONCRETE PAVING



FENCE



COBBLE



SCUPPER



PLANTER POTS

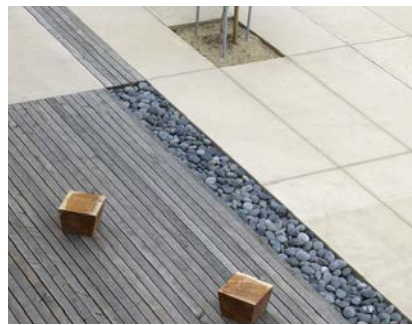

WOOD DECKING



STEEL PLANTER

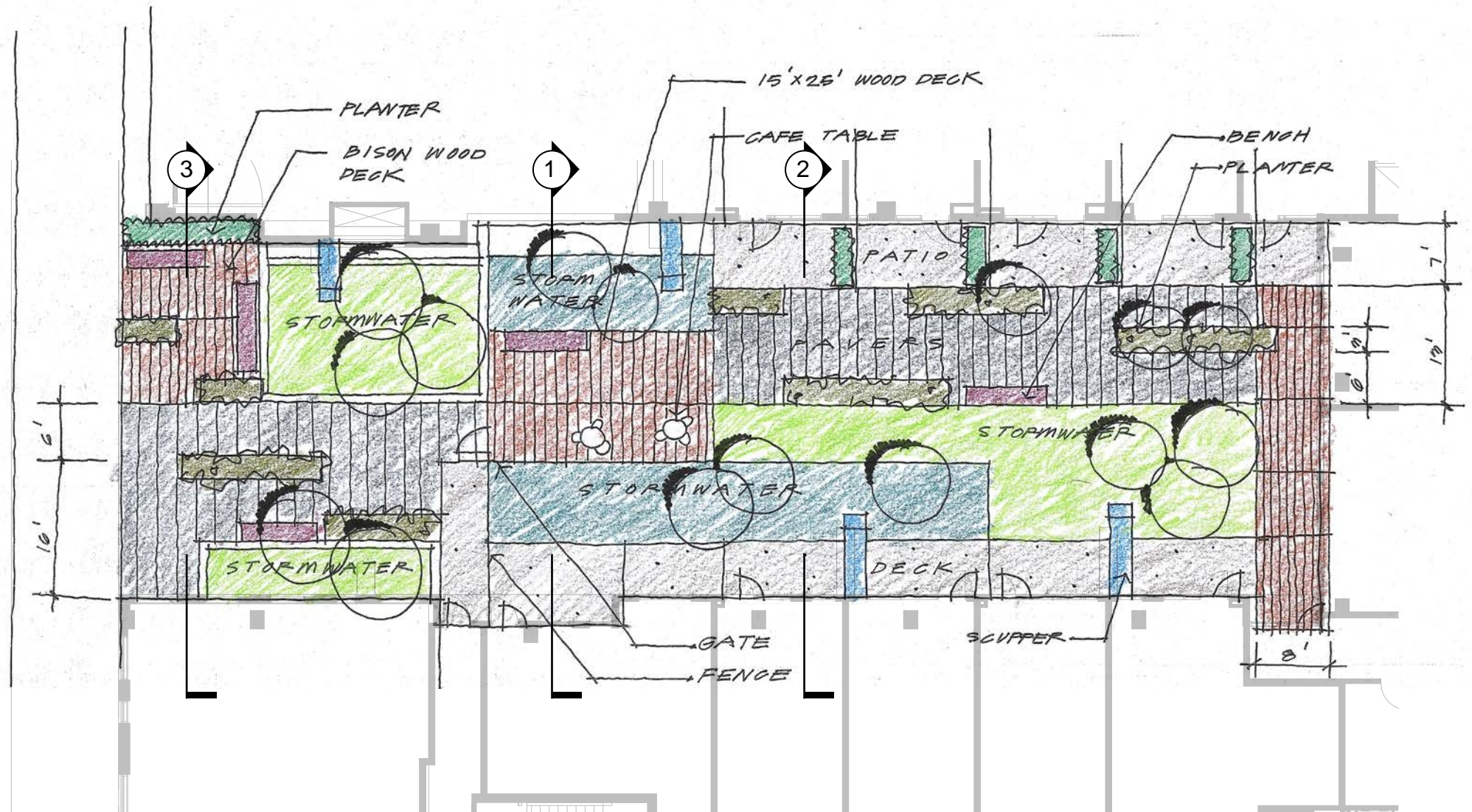

SEE SHEETS C18-C21 FOR SECTIONS



STORMWATER PLANTS



VINE MAPLE



CALIFORNIA GRAY RUSH



ORANGE SEDGE



SWORD FERN

# PLANT MATERIAL SCHEDULE

TYPE	SYMBOL	BOTANICAL NAME	COMMON NAME	SIZE	SPACING
TREES		ACER CIRCINATUM	VINE MAPLE	3" CALIPER-MULTI TRUNK	PER PLAN
STREET TREE		CARPINUS BETULUS 'FASTIGIATA'	PYRAMIDAL EUROPEAN HORNBEAM	3.5" CALIPER	PER PLAN
SHRUBS		NANDINA DOMESTICA 'HARBOUR DWARF'	HEAVENLY BAMBOO	5-GALLON	24" ON-CENTER
HERBACEOUS PLANTS/ GRASSES		CAREX TESTACEA JUNCUS PATENS POLYSTICHUM MUNITUM	NEW ZEALAND ORANGE SEDE SPREADING RUSH SWORDFERN	1 GALLON 1 GALLON 1 GALLON	12" ON-CENTER 12" ON-CENTER 12" ON-CENTER
VINES		AKEBIA QUINATA	FIVELEAF AKEBIA	5 GALLON	36" ON-CENTER

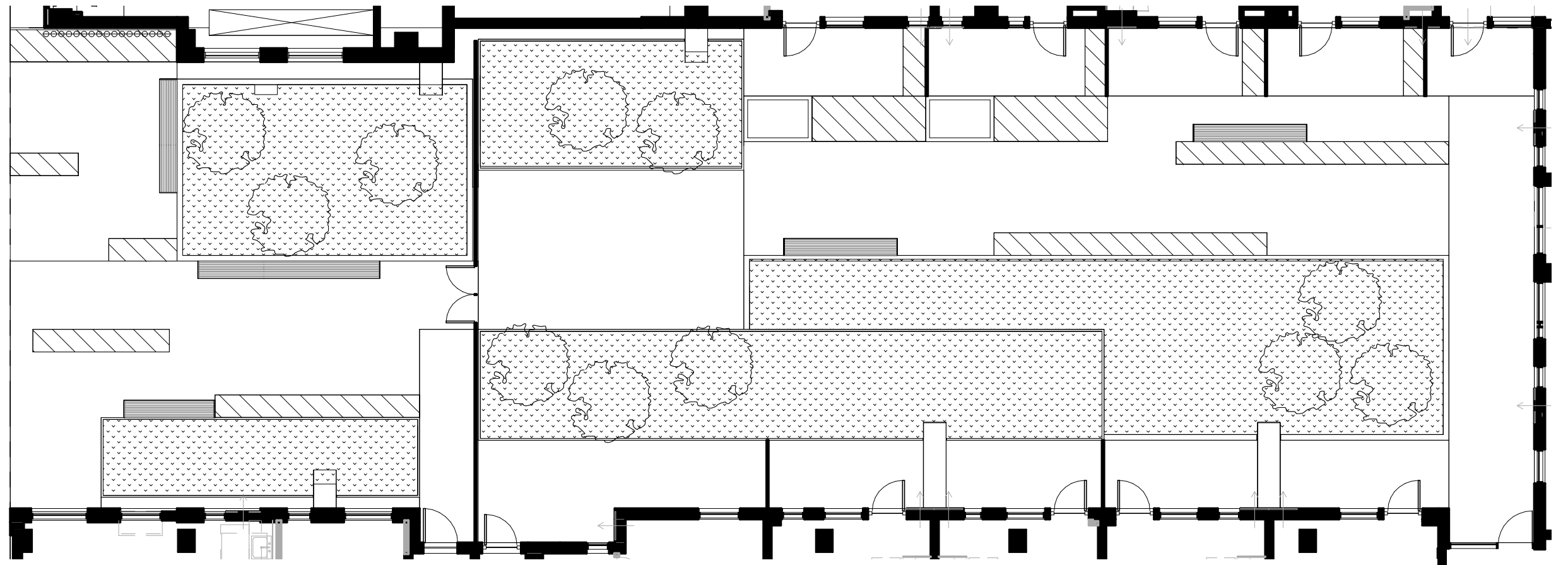

COURTYARD PLANTING PLAN 1



**LANDSCAPE MATERIALS**



**FIRE TABLE**



**TERRACE CHARACTER**



**PLANTER POTS**



**OUTDOOR FURNITURE**



**CONCRETE PAVERS**

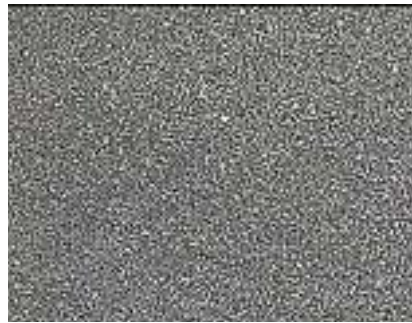

**CONCRETE PAVING**



**PLANTER POTS**



**PAVERS/FURNITURE**

**PLANTS**



**SCREENING SHRUB**



**ORNAMENTAL GRASS**



**PERENNIALS**

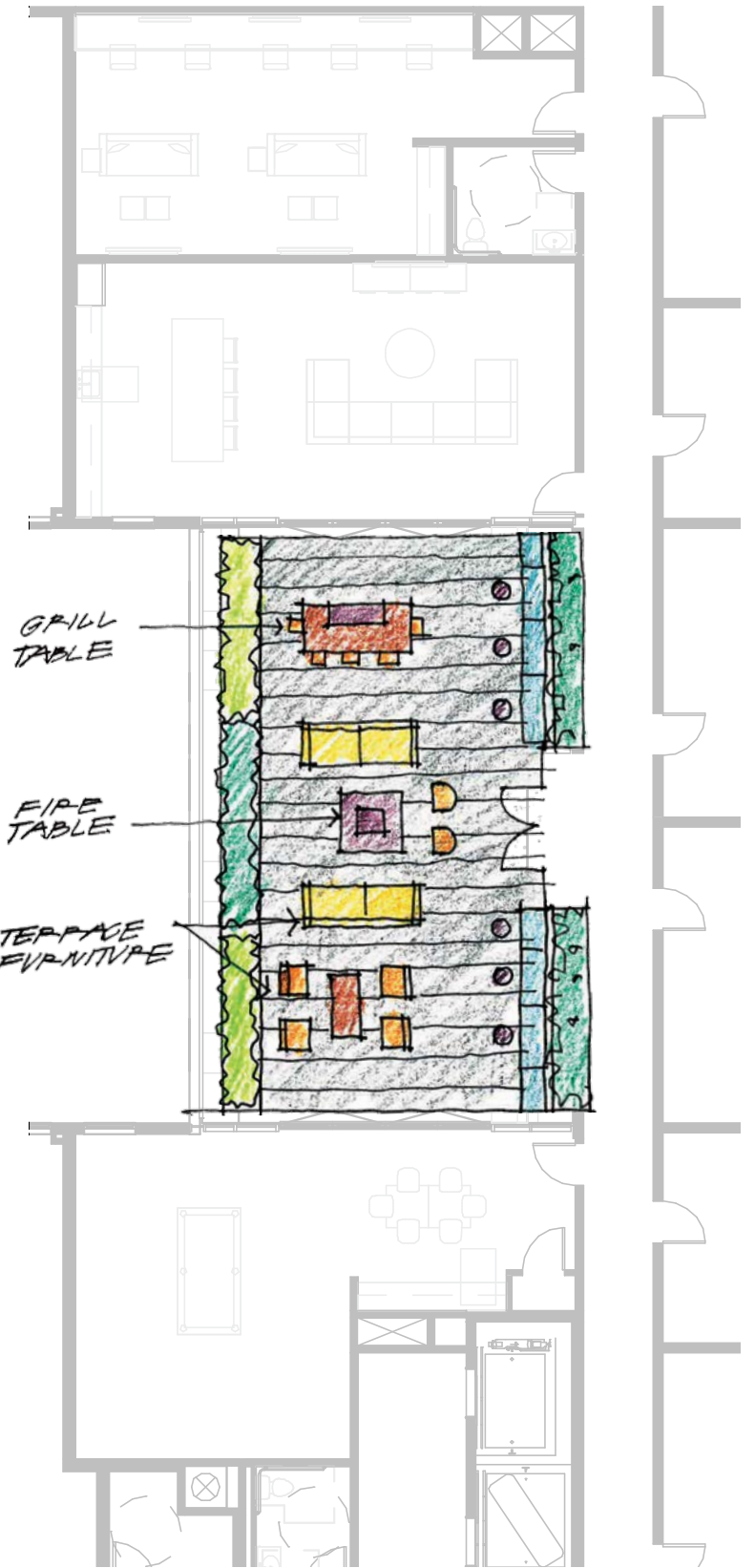

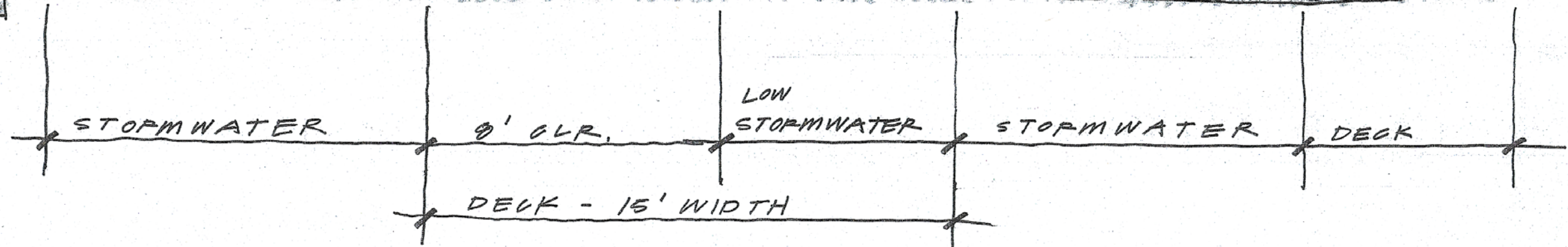

LANDSCAPE SECTION  
AT DECK (1)

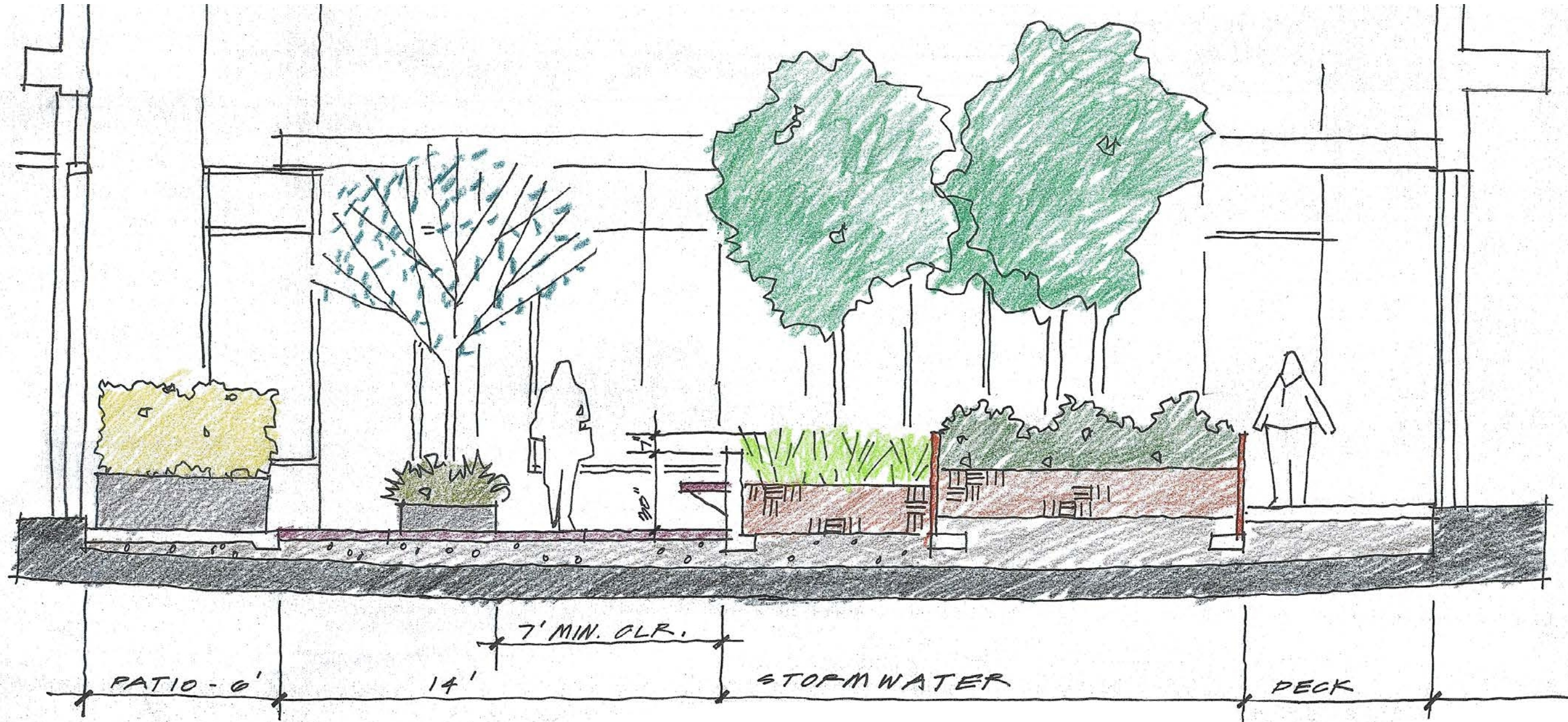

LANDSCAPE SECTION ②  
AT PATIO



LANDSCAPE SECTION  
AT COURTYARD

3

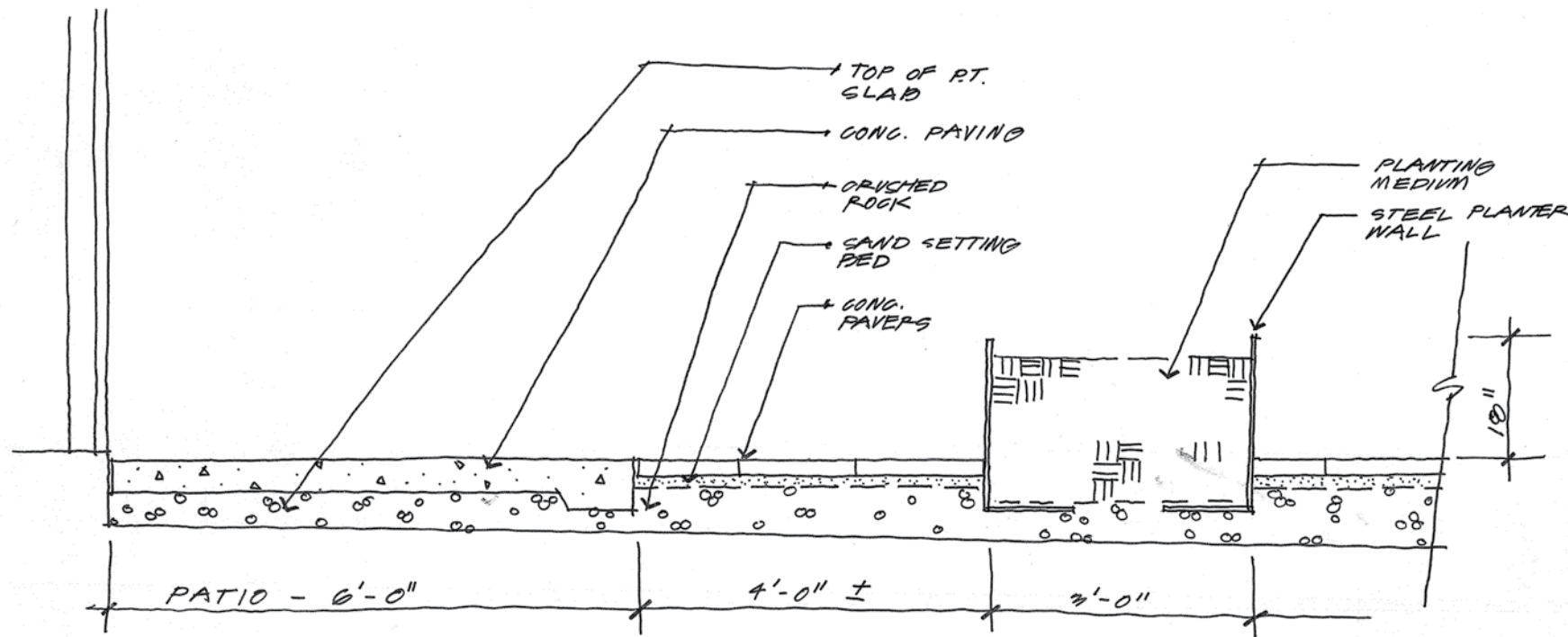

PATIO / PAVERS / LOW PLANTER DETAIL

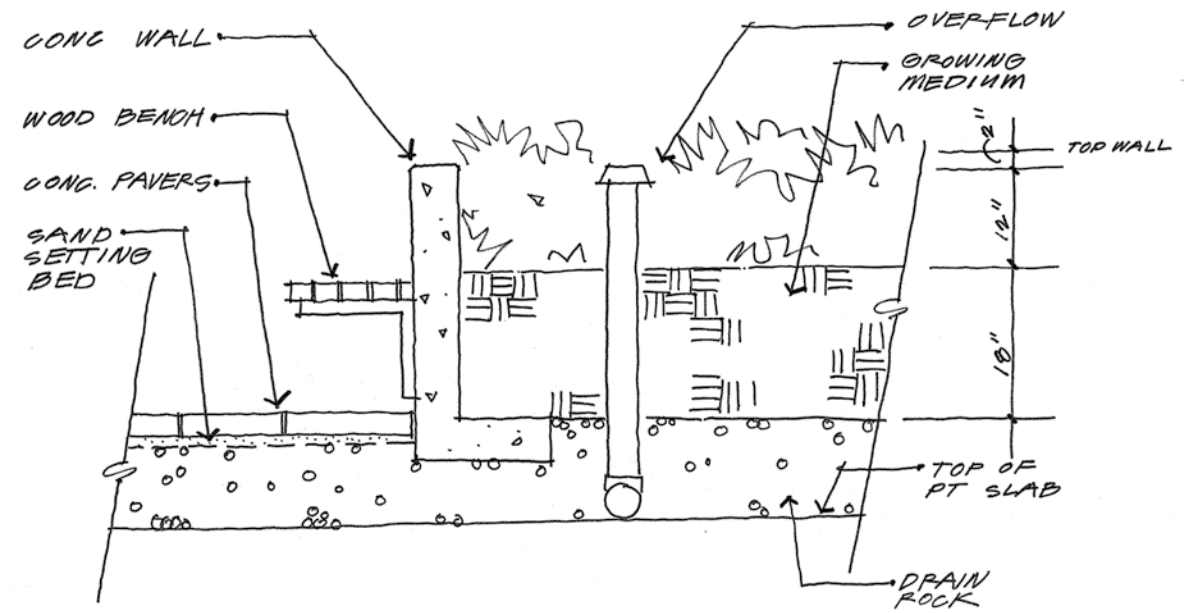

STORMWATER PLANTER (LOW) @ PAVERS

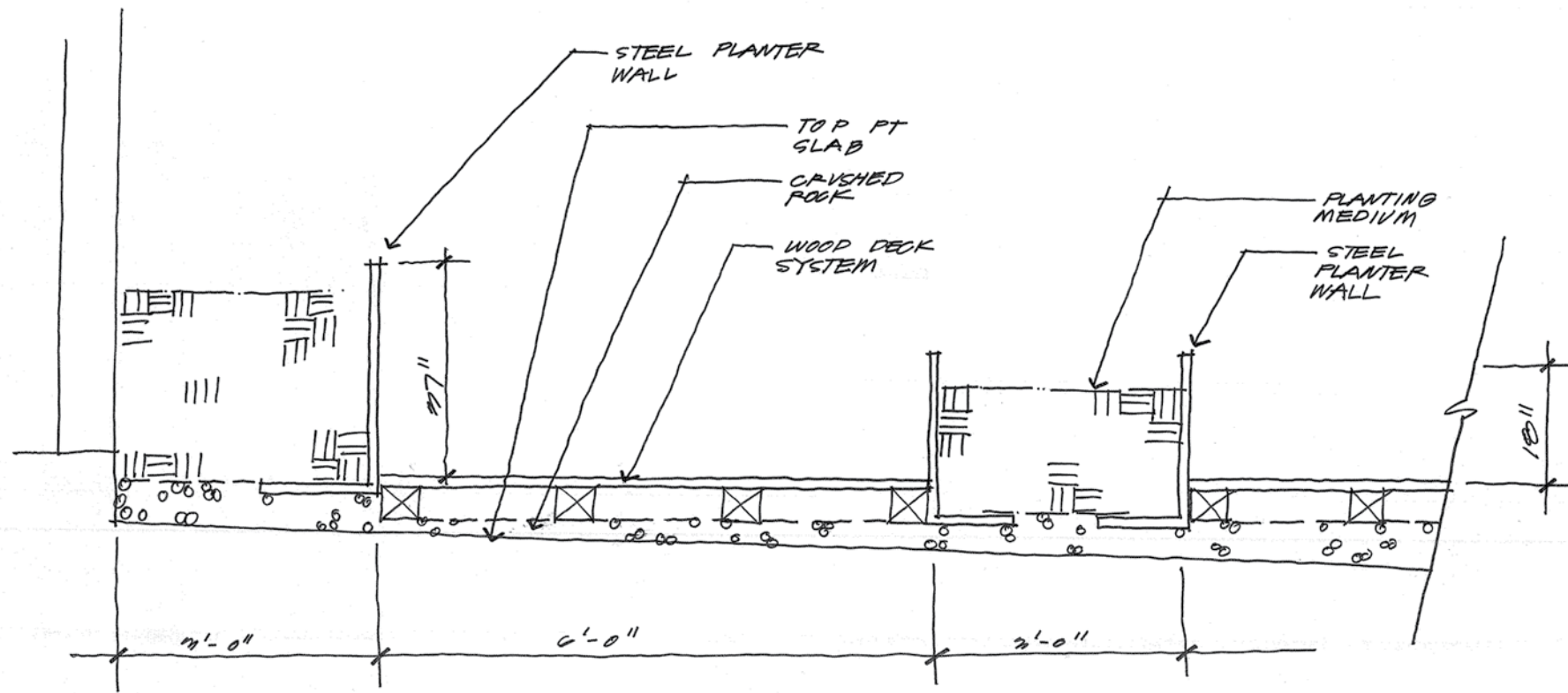

STEEL PLANTERS / DECK @ COURTYARD DETAIL

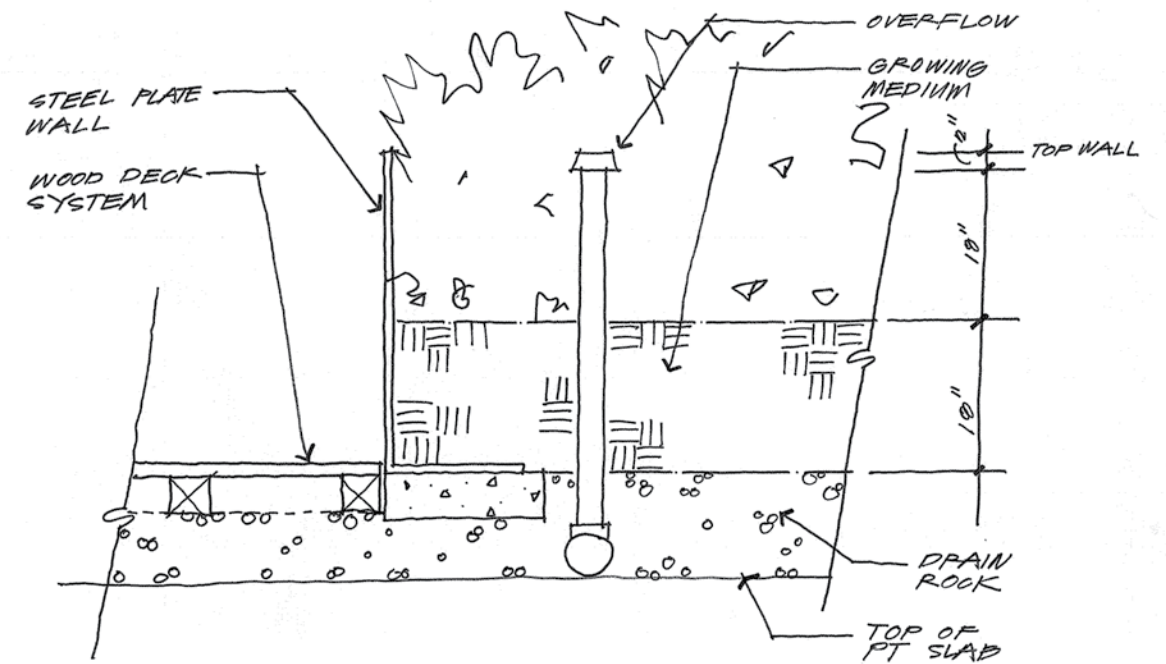

STORMWATER PLANTER (TALL) @ WOOD DECK

1/2" = 1'-0" TYP

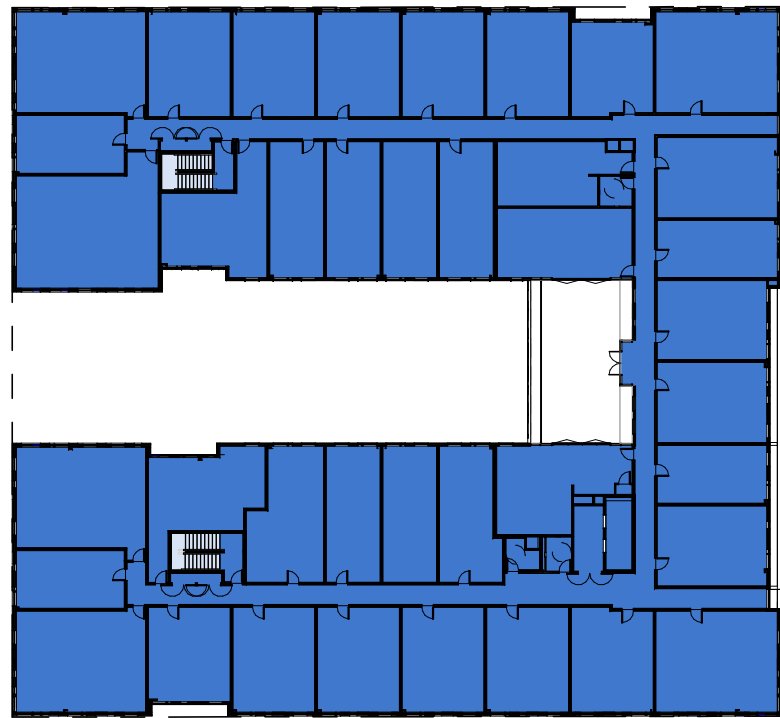

LEVEL 6 ③

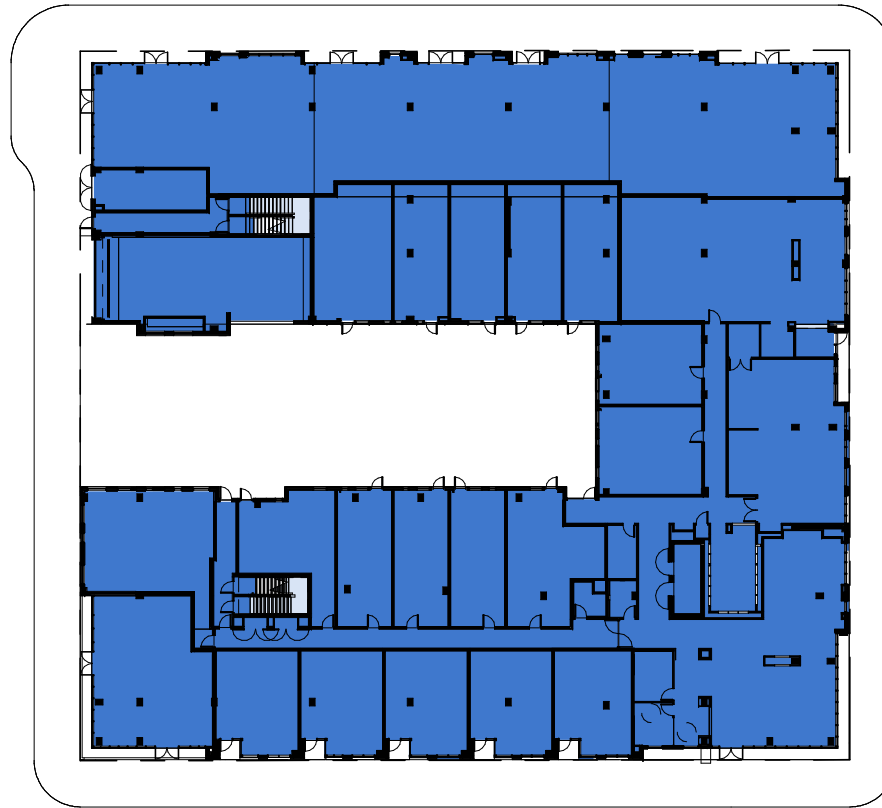

LEVEL 1 ①

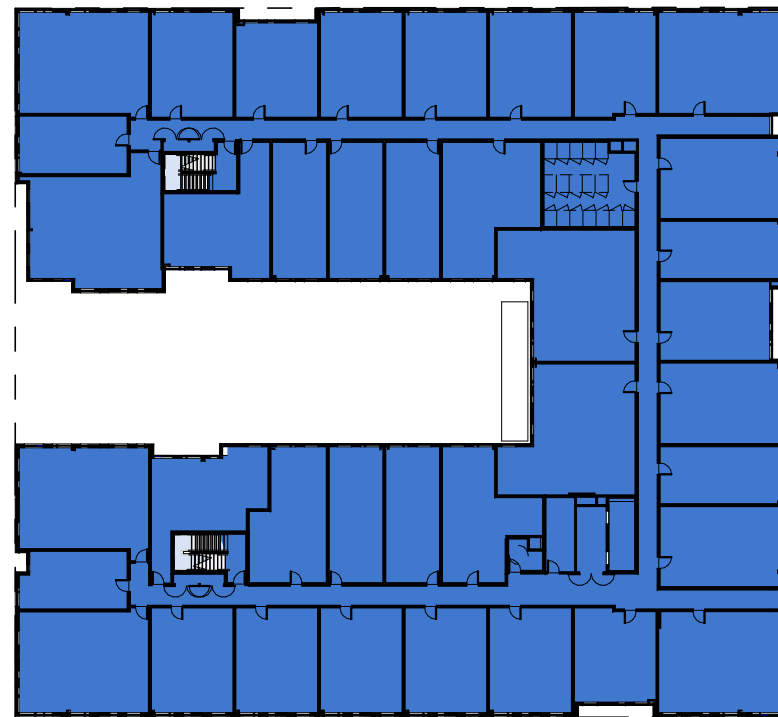

LEVELS 2-5 ②

29,793 SF	LEVEL 1
30,856 SF	LEVEL 2
30,856 SF	LEVEL 3
30,917 SF	LEVEL 4
31,050 SF	LEVEL 5
29,686 SF	LEVEL 6
<hr/>	
183,158 SF	FAR TOTAL
332,235 SF	ALLOWABLE

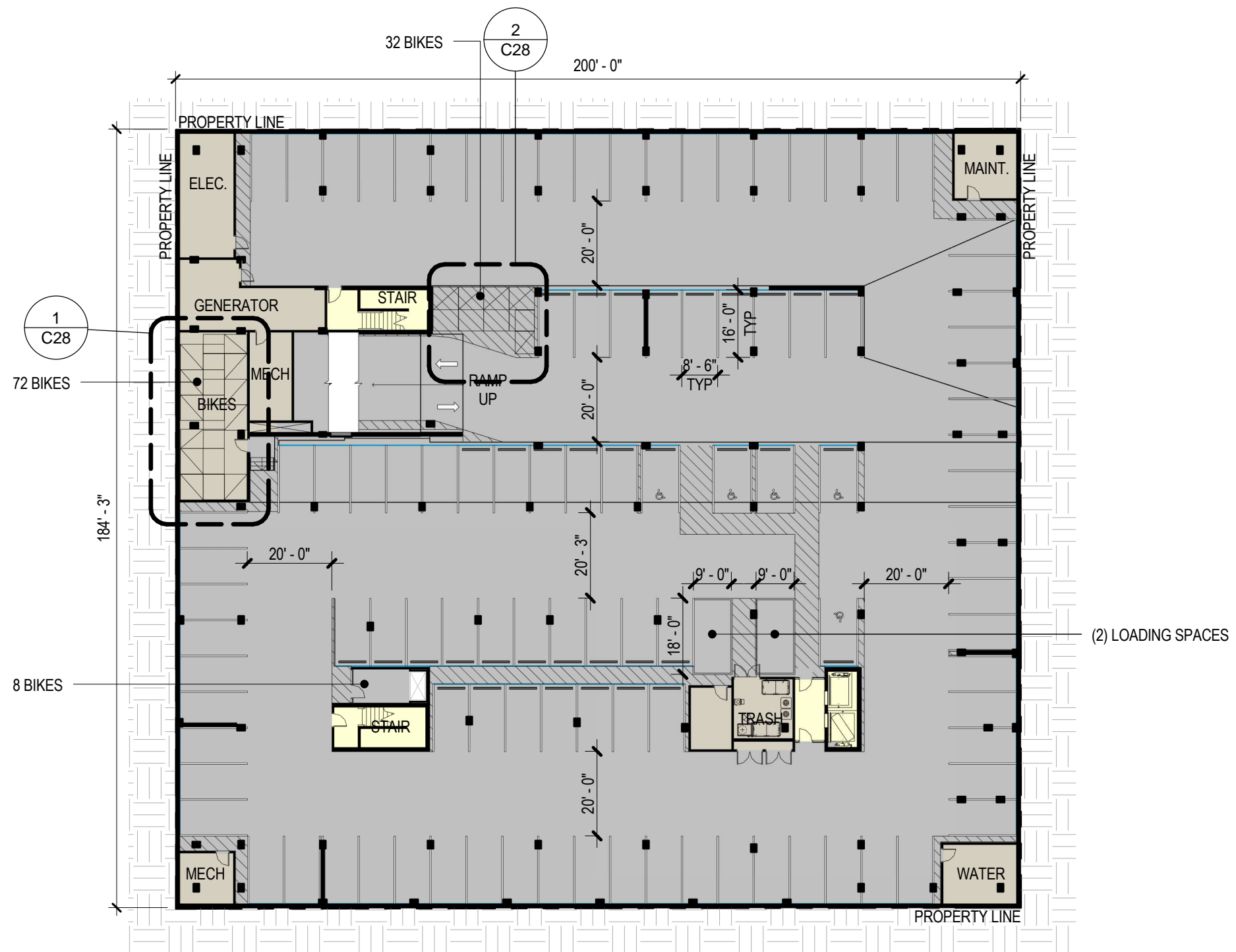

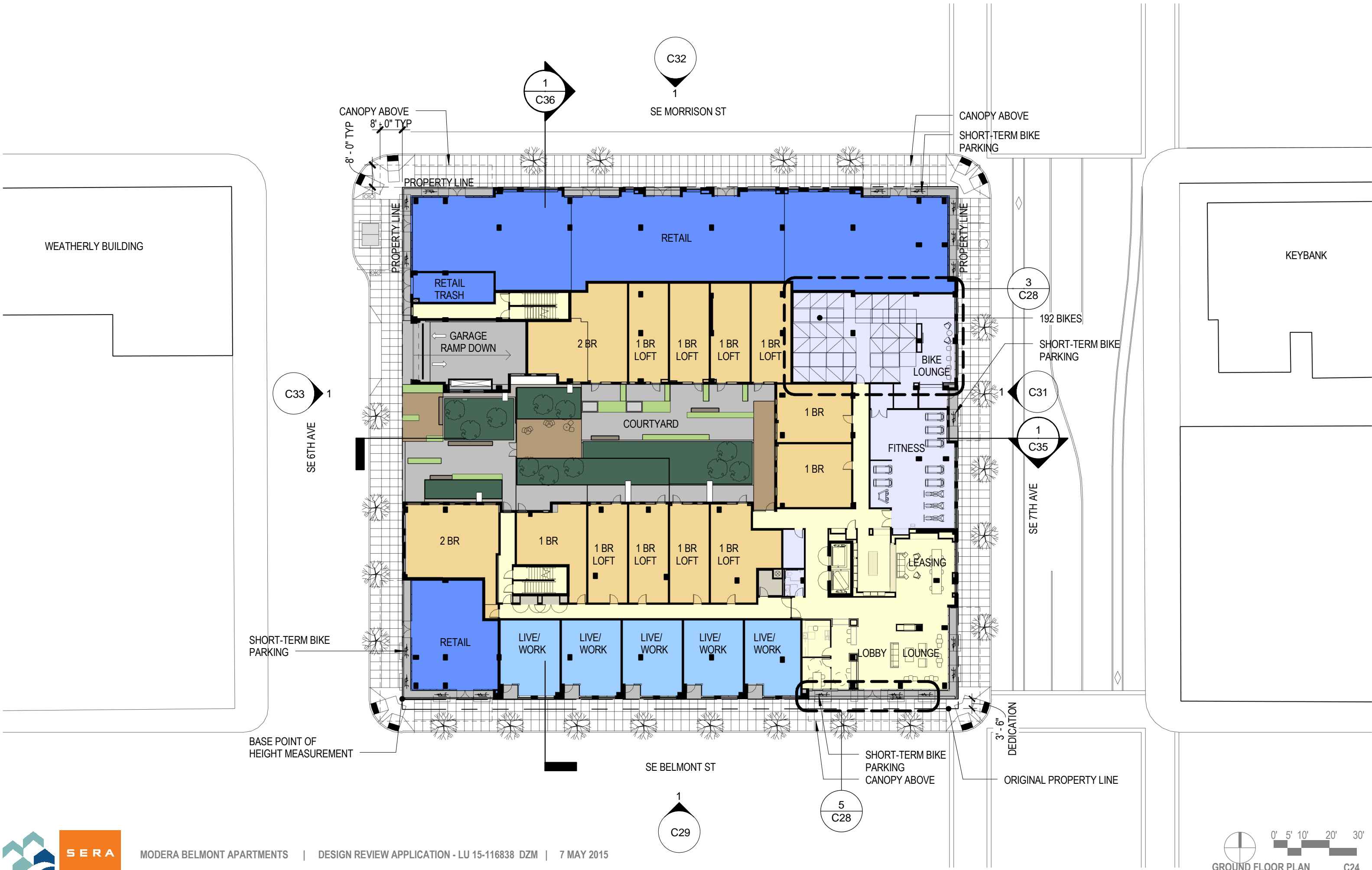





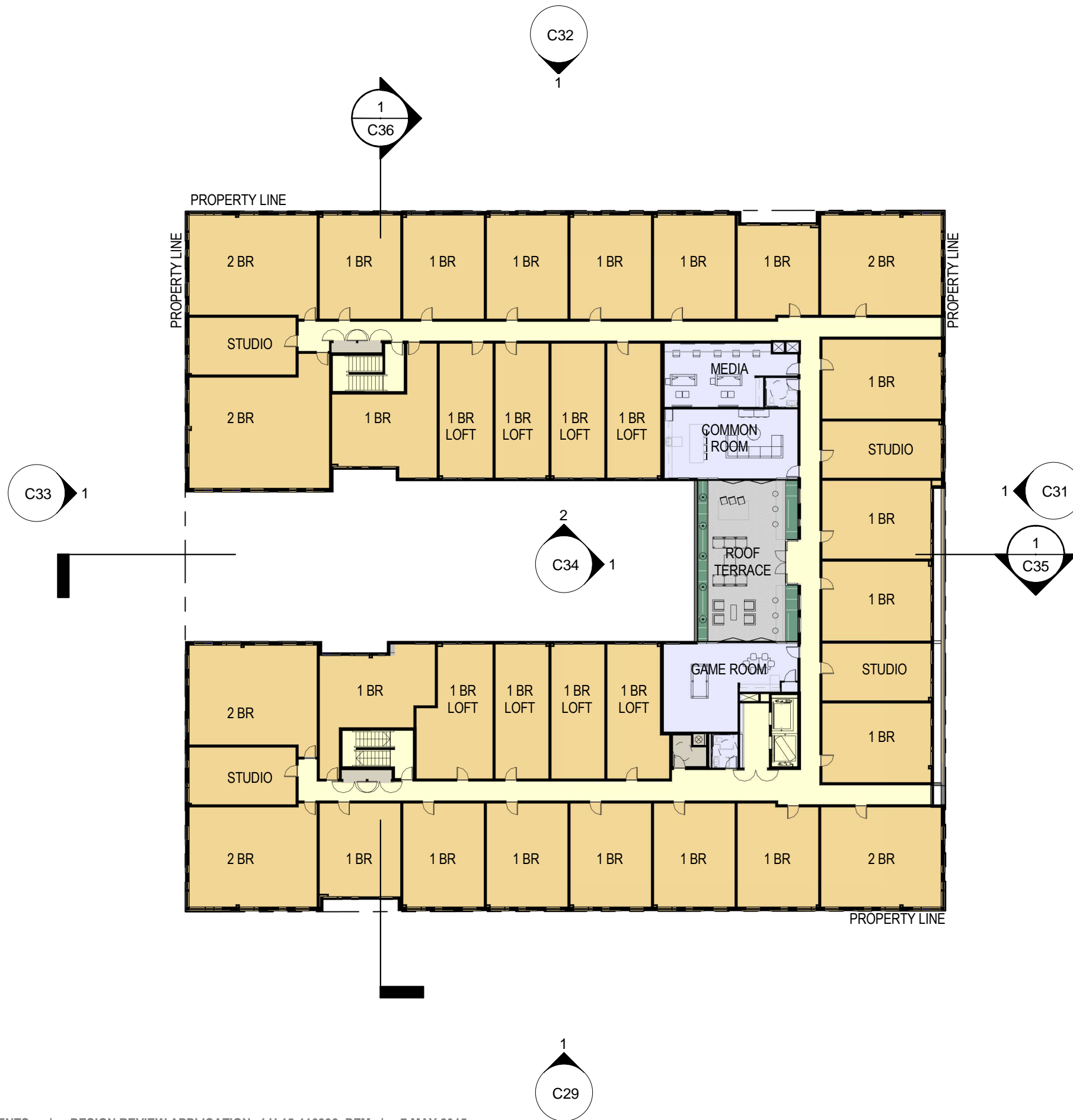

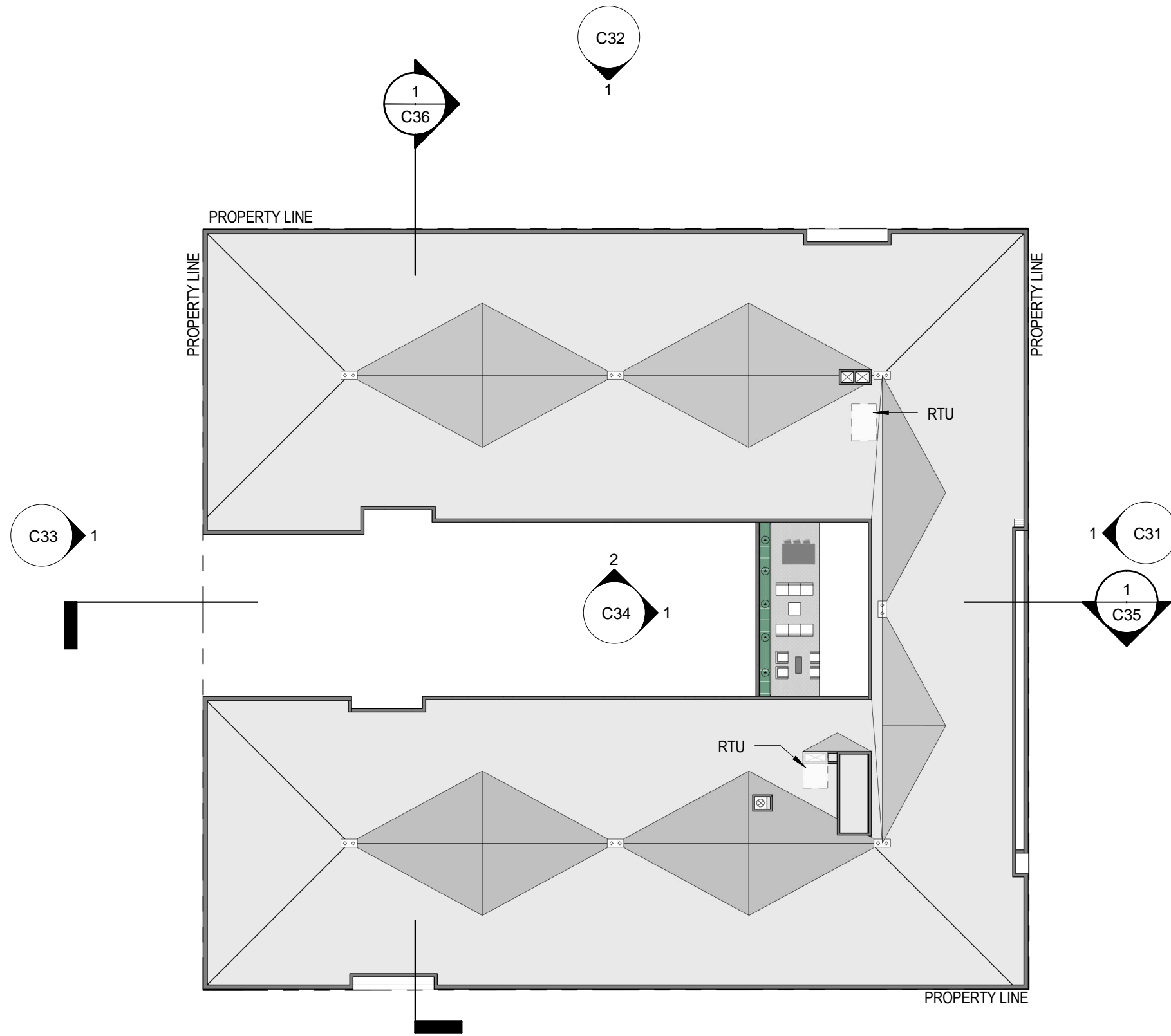

# BICYCLE PARKING

PER CITY OF PORTLAND PLANNING AND ZONING CODE - CHAPTER 33.266, TABLE 266-6

## LONG TERM BIKE PARKING REQUIREMENT:

RESIDENTIAL: 1.5 PER 1 UNIT ∴ 206 UNITS X 1.5 = 309 SPACES REQUIRED  
 RETAIL SALES: 2, OR 1 PER 12,000 SF; (7,300 SF RETAIL AREA) ∴ 2 SPACES REQUIRED  
 TOTAL: 311 312 SPACES PROVIDED

## SHORT TERM BIKE PARKING REQUIREMENT:

RESIDENTIAL: 1 SPACE PER 20 UNITS ∴ 206 UNITS/20 = 11 SPACES REQUIRED  
 RETAIL SALES: 2, OR 1 SPACE PER 5,000 SF; (7,300 SF RETAIL AREA) ∴ 2 SPACES REQUIRED  
 TOTAL: 13 36 SPACES PROVIDED, SEE GROUND FLOOR PLAN



**GROUND FLOOR BIKE ROOM** ③  
190 LONG TERM BIKE PARKING SPACES

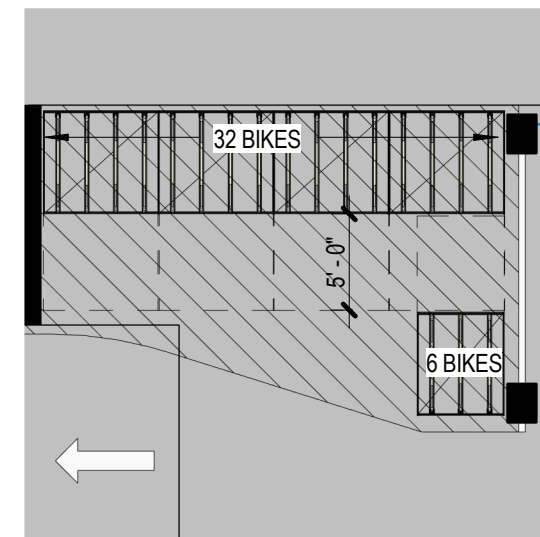

**PARKING LEVEL BIKES** ②  
38 LONG TERM BIKE PARKING SPACES

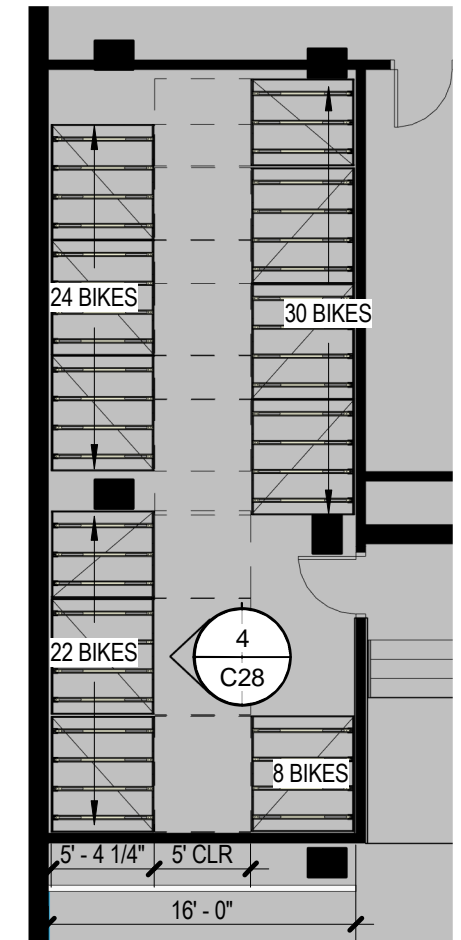

**PARKING LEVEL BIKE ROOM** ①  
84 LONG-TERM BIKE PARKING SPACES

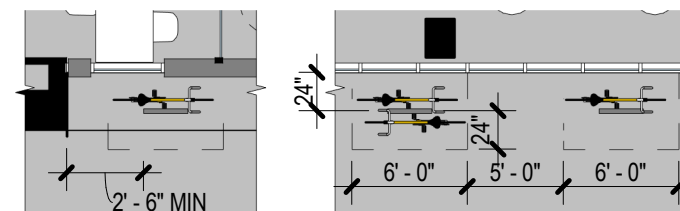

**SHORT-TERM BIKE PARKING** ⑤

SARIS8016 = 6 BIKE CAPACITY PER RACK  
 SARIS 8080 = 8 BIKE CAPACITY PER RACK

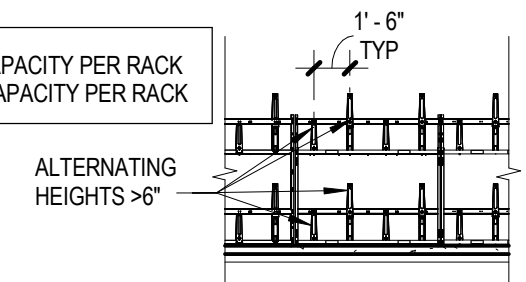

**TYP BIKE RACK - FRONT** ④

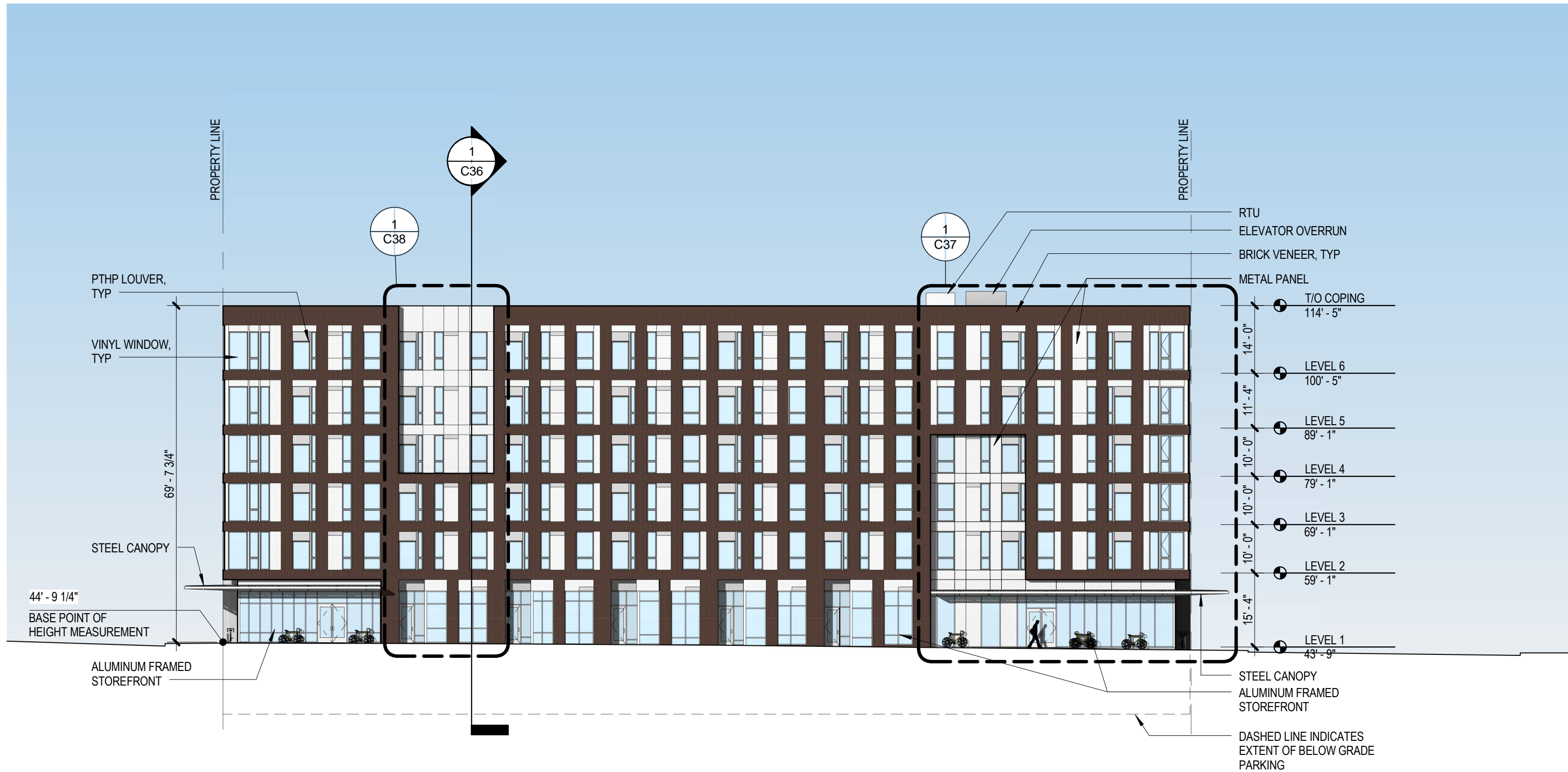

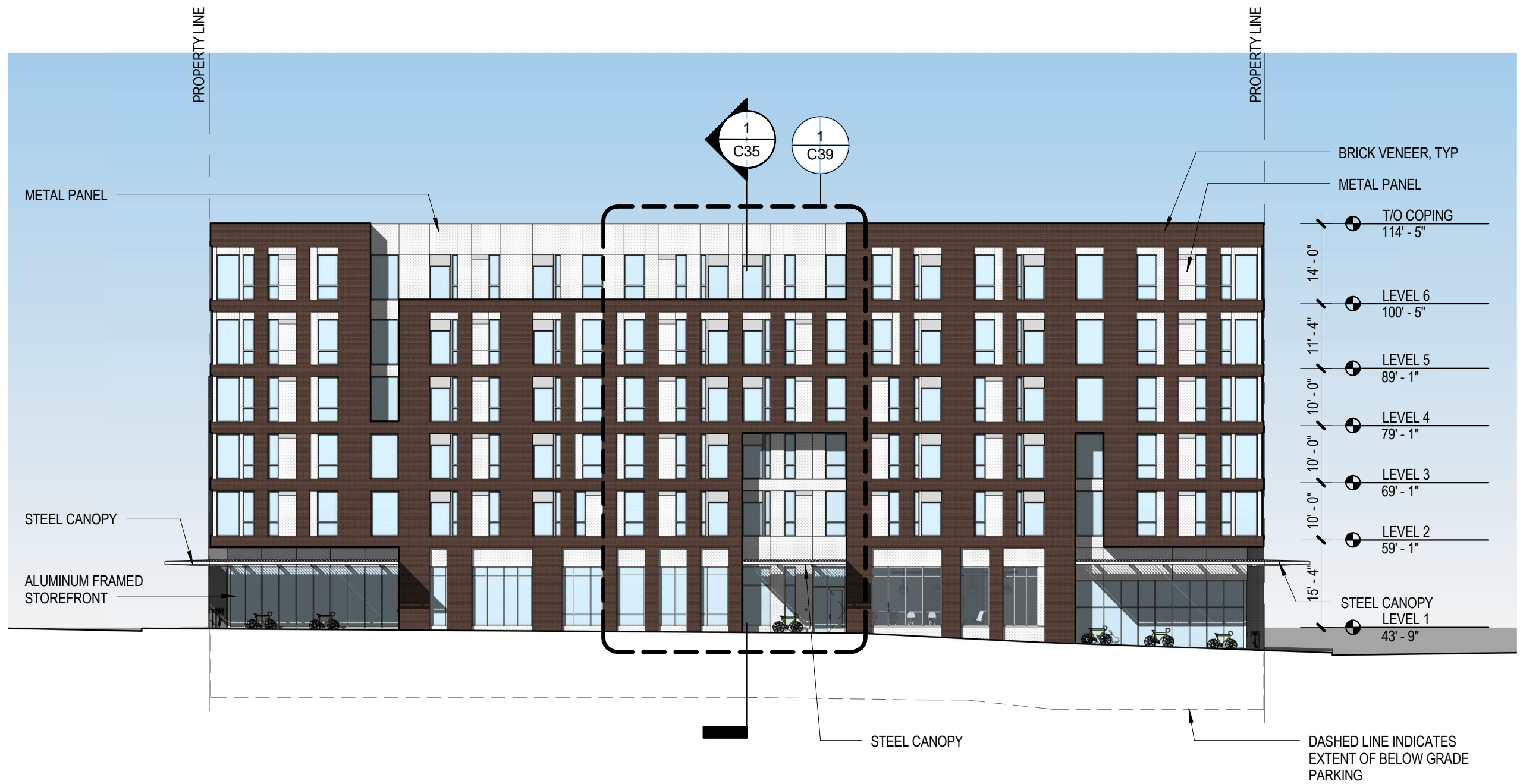



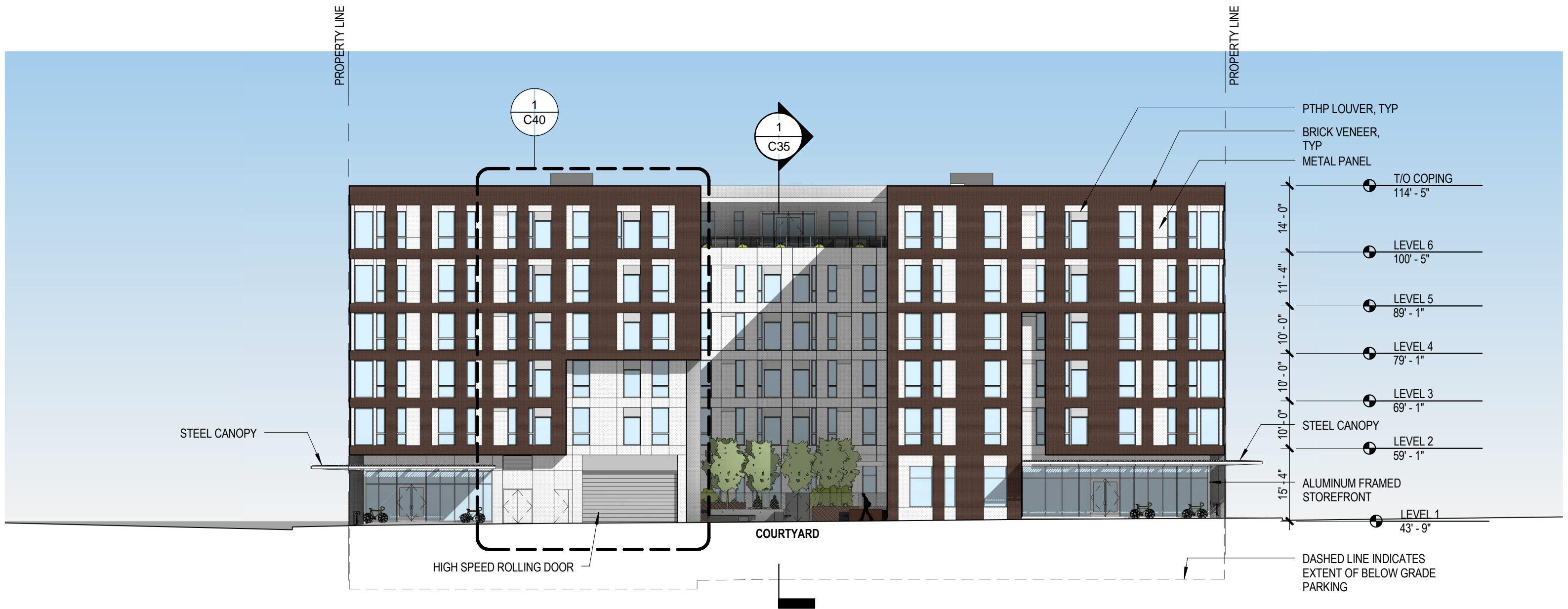



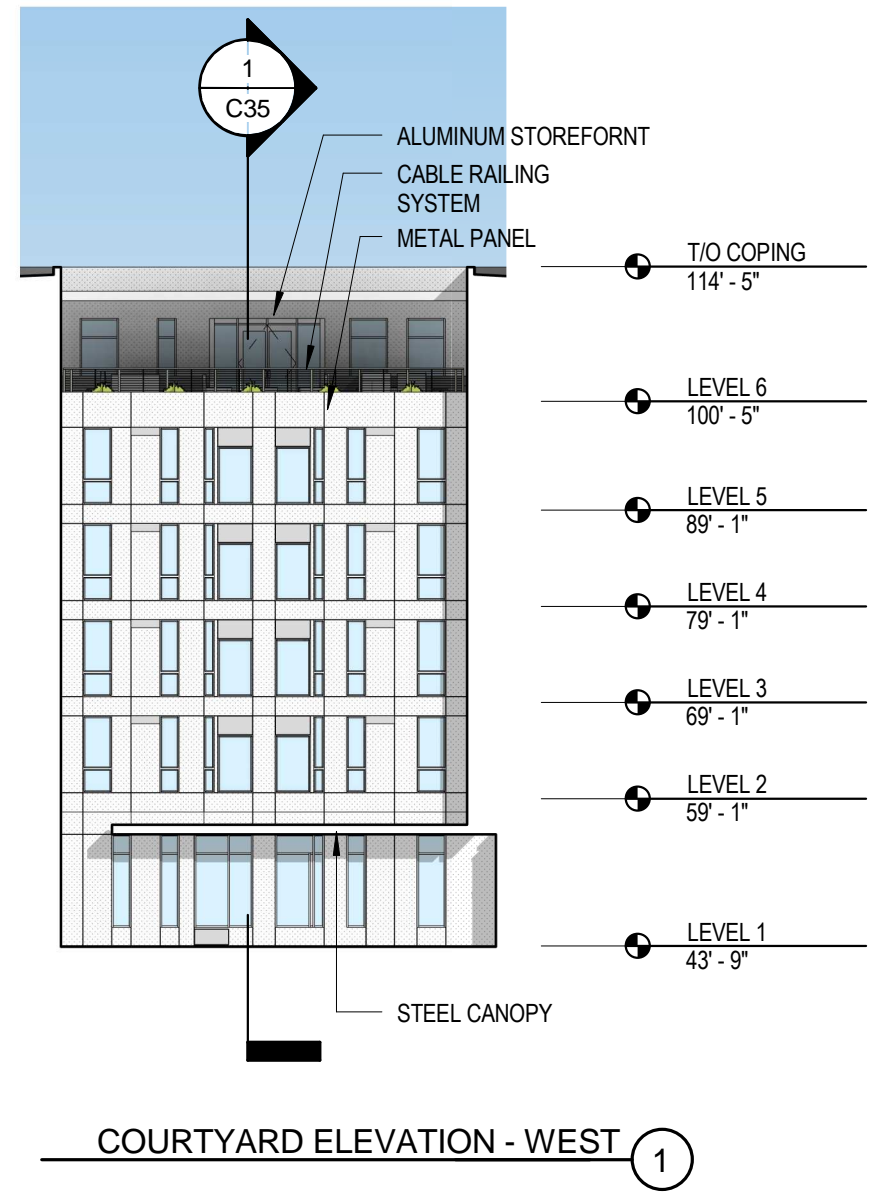
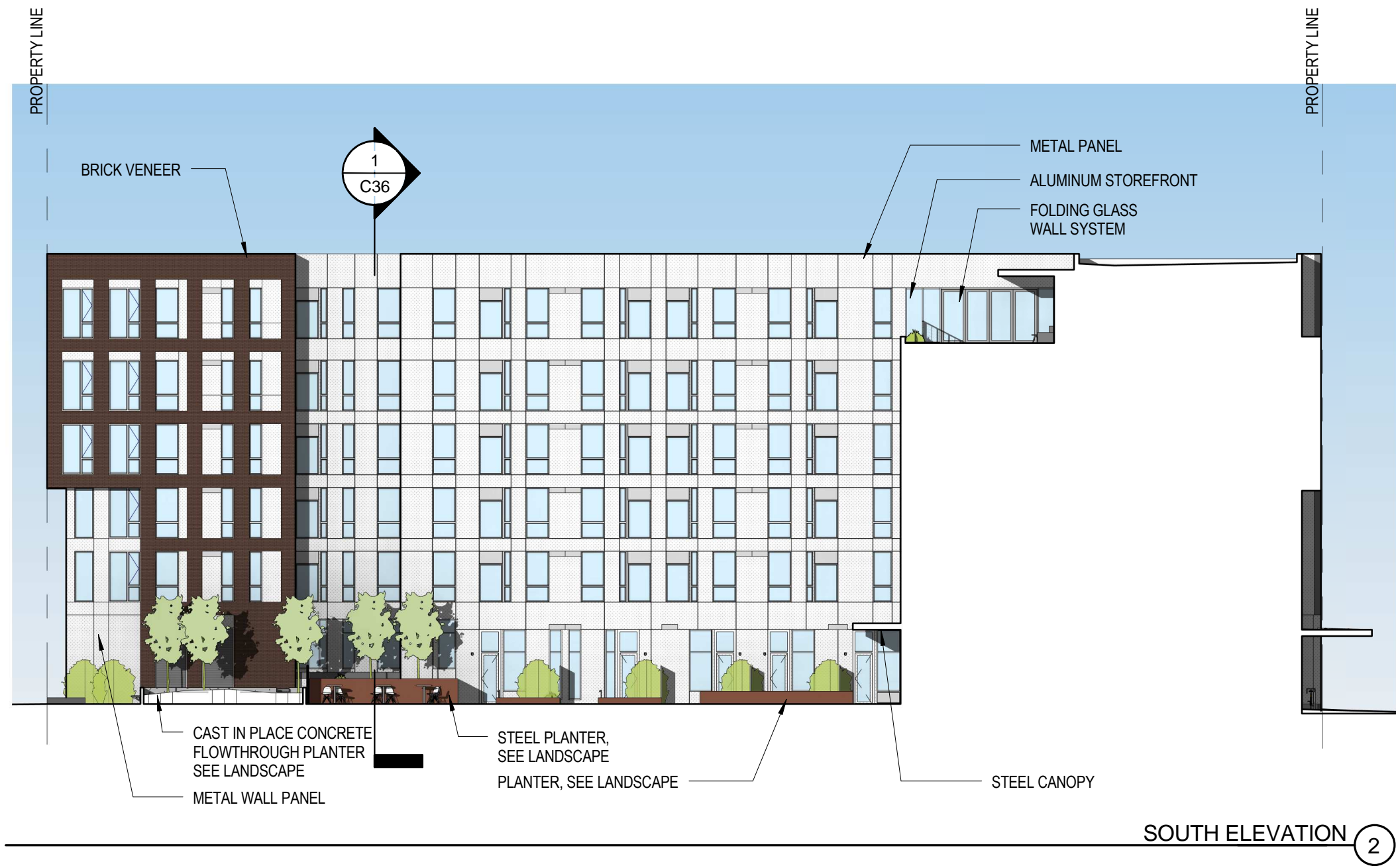

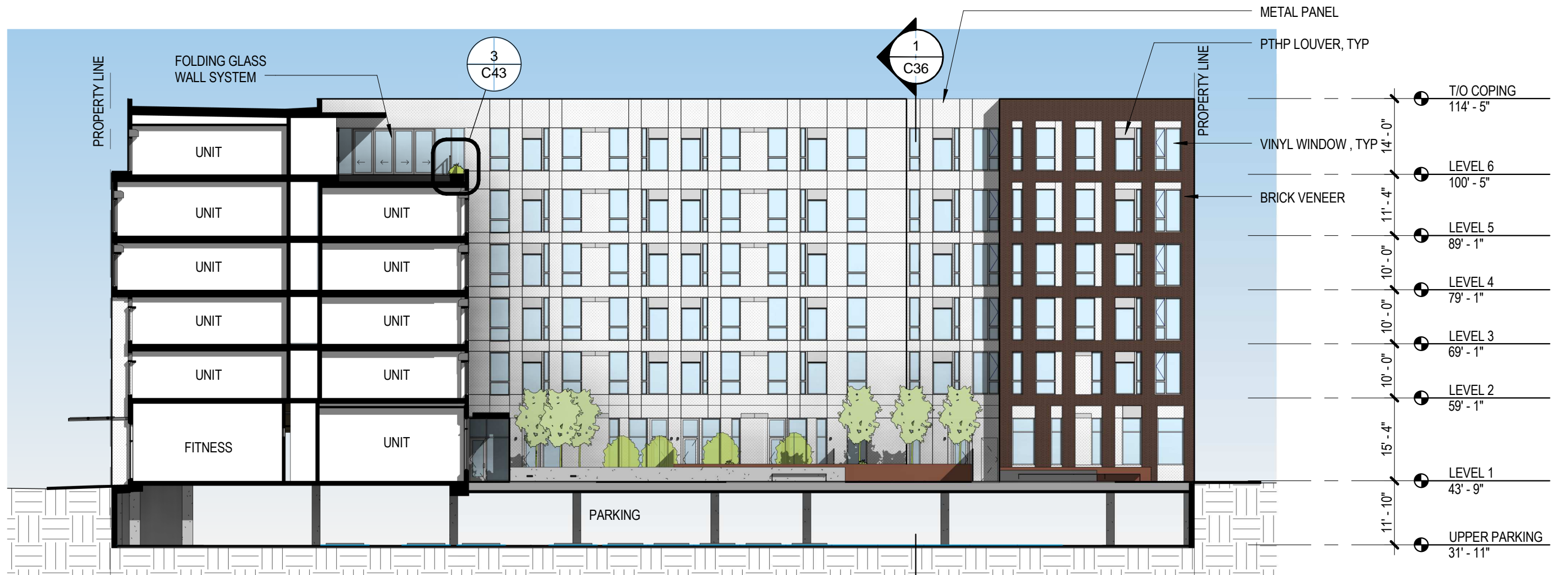

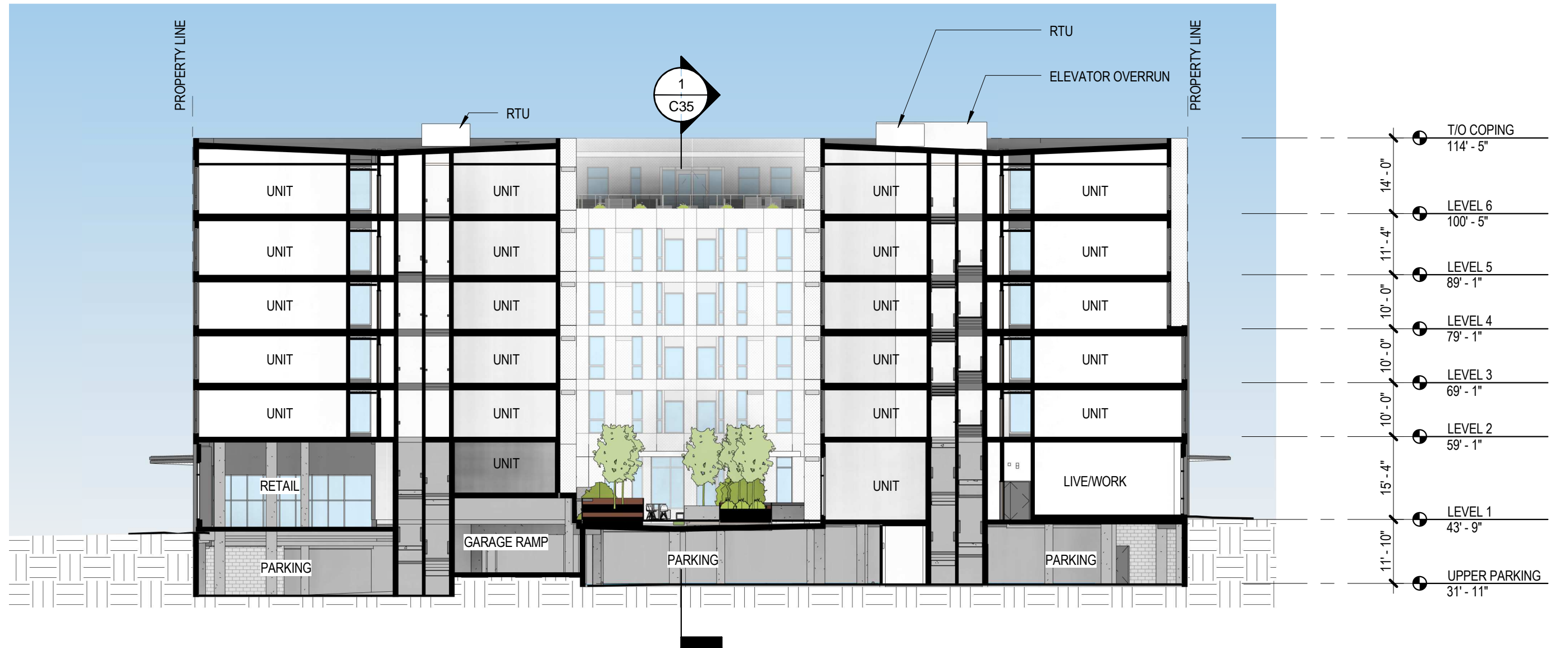

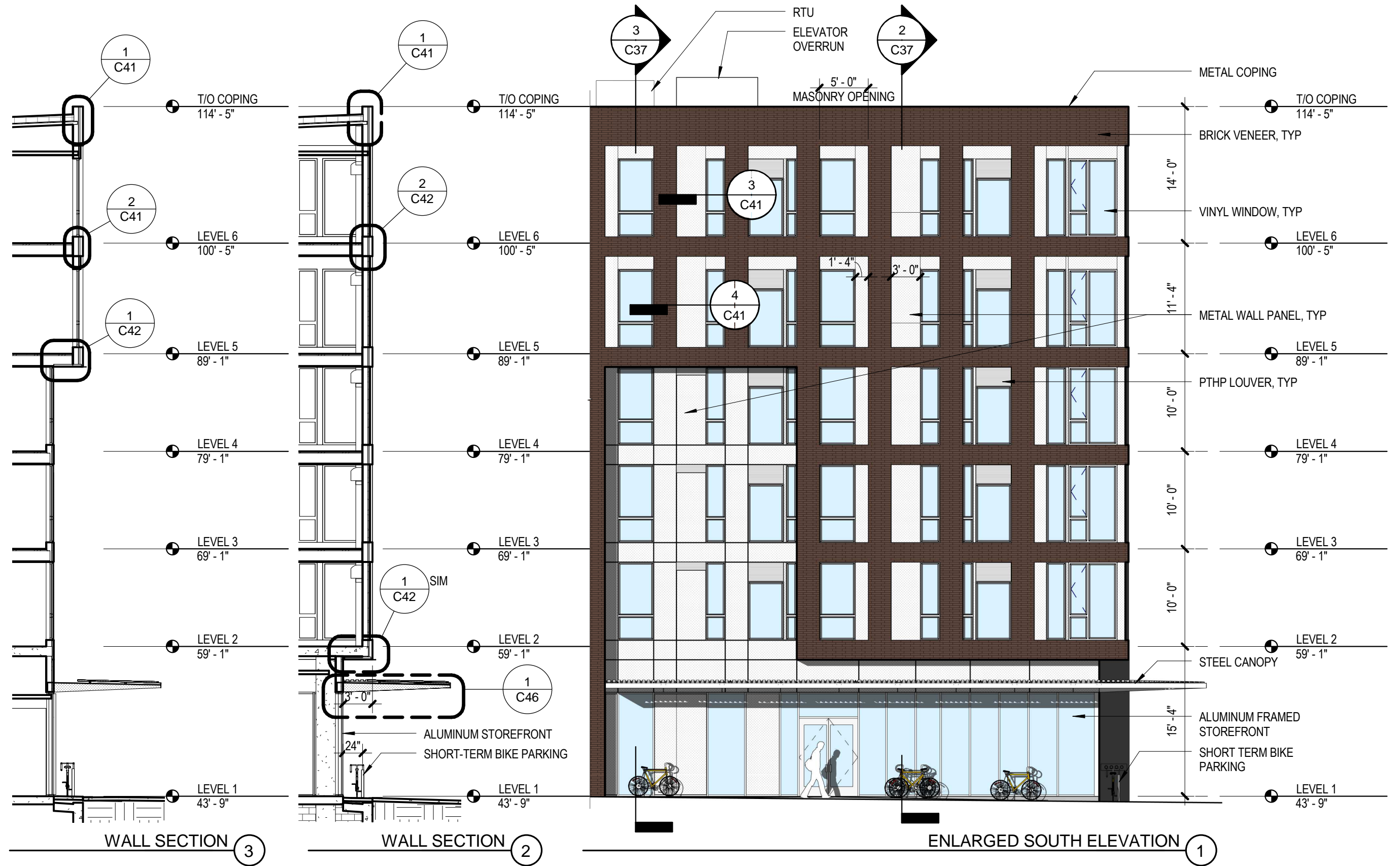

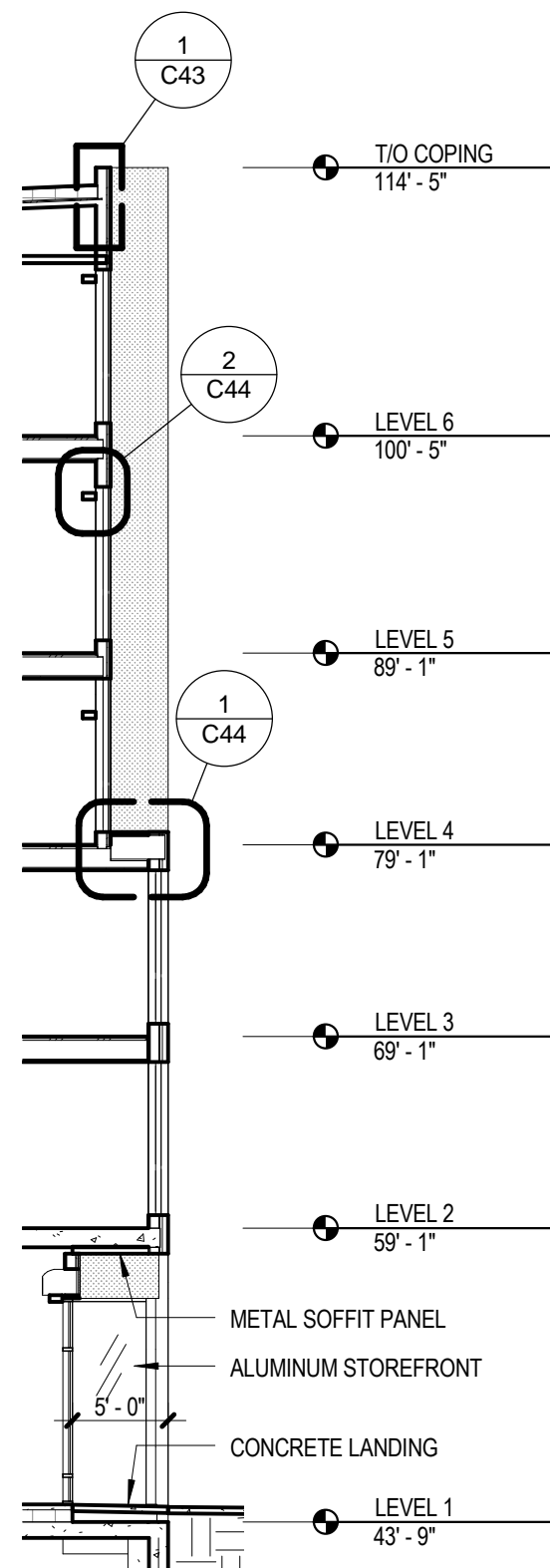

LIVE/WORK ENTRY WALL SECTION ③

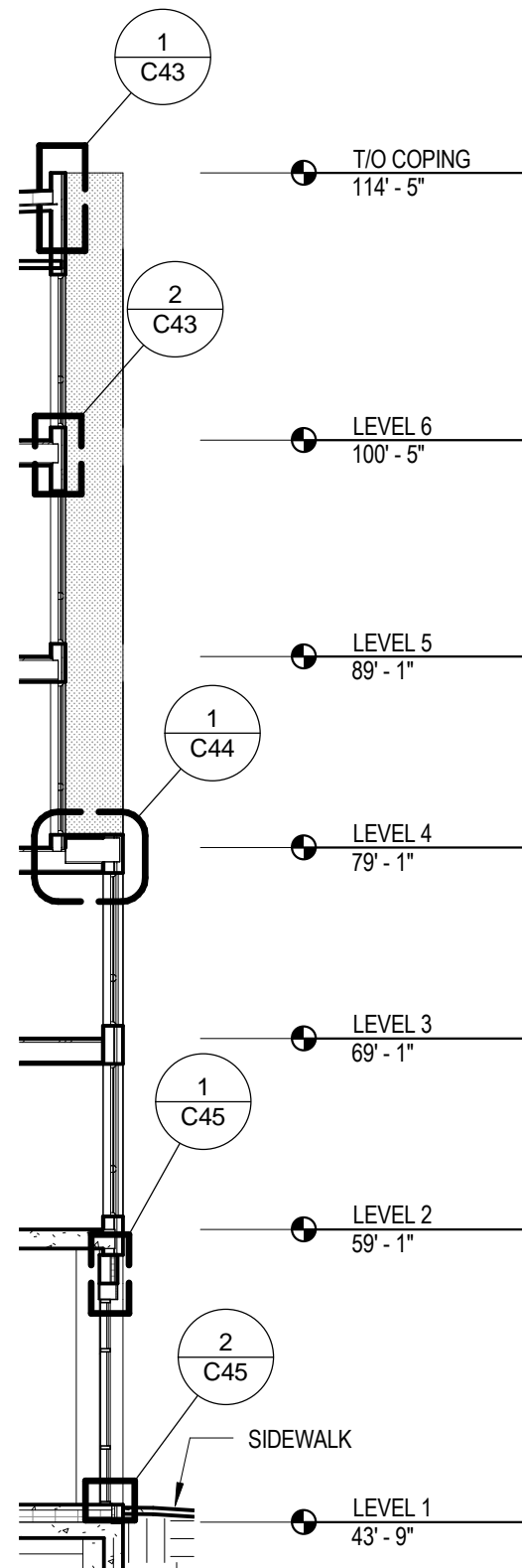

WALL SECTION ②

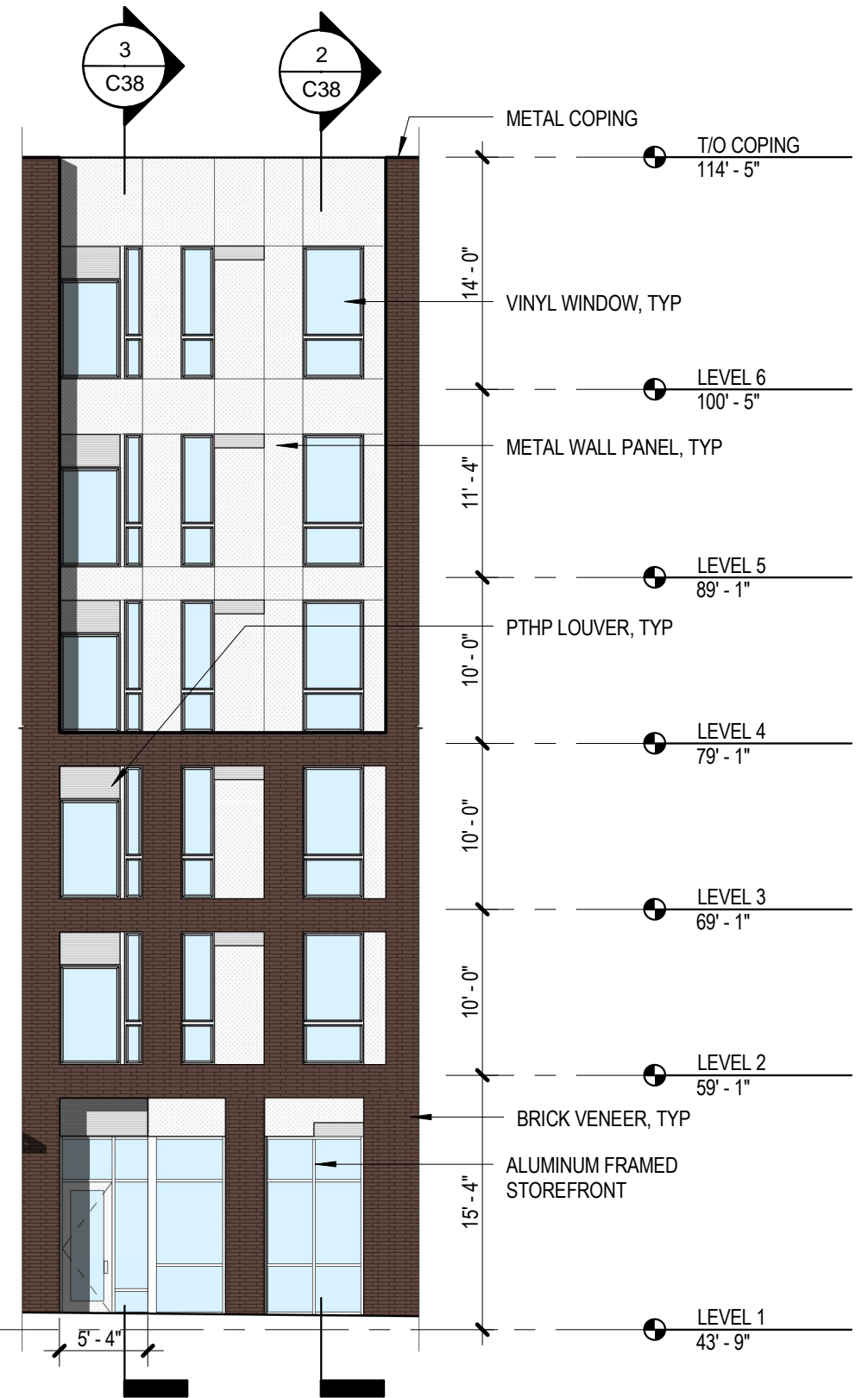

ENLARGED SOUTH ELEVATION ①

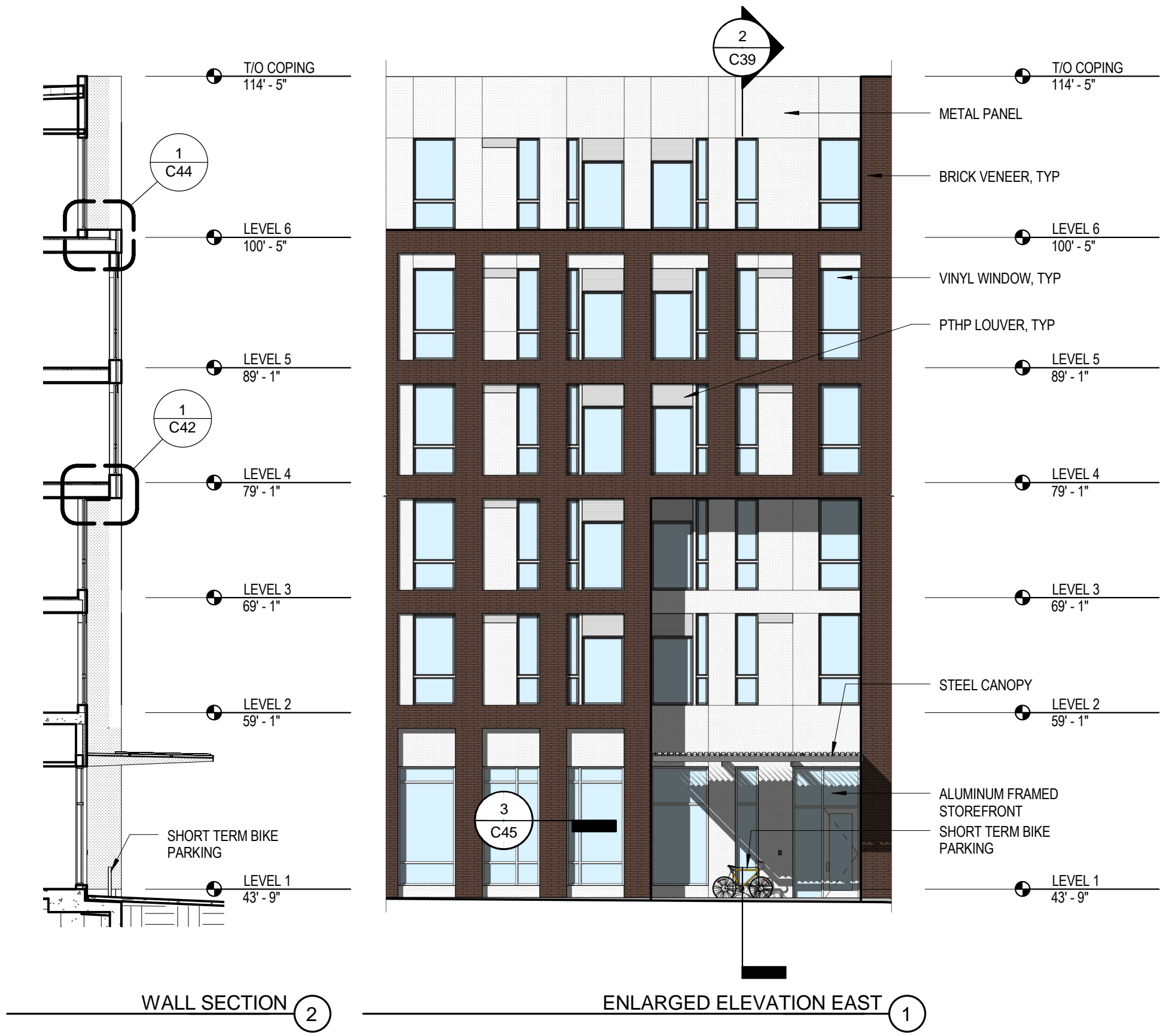

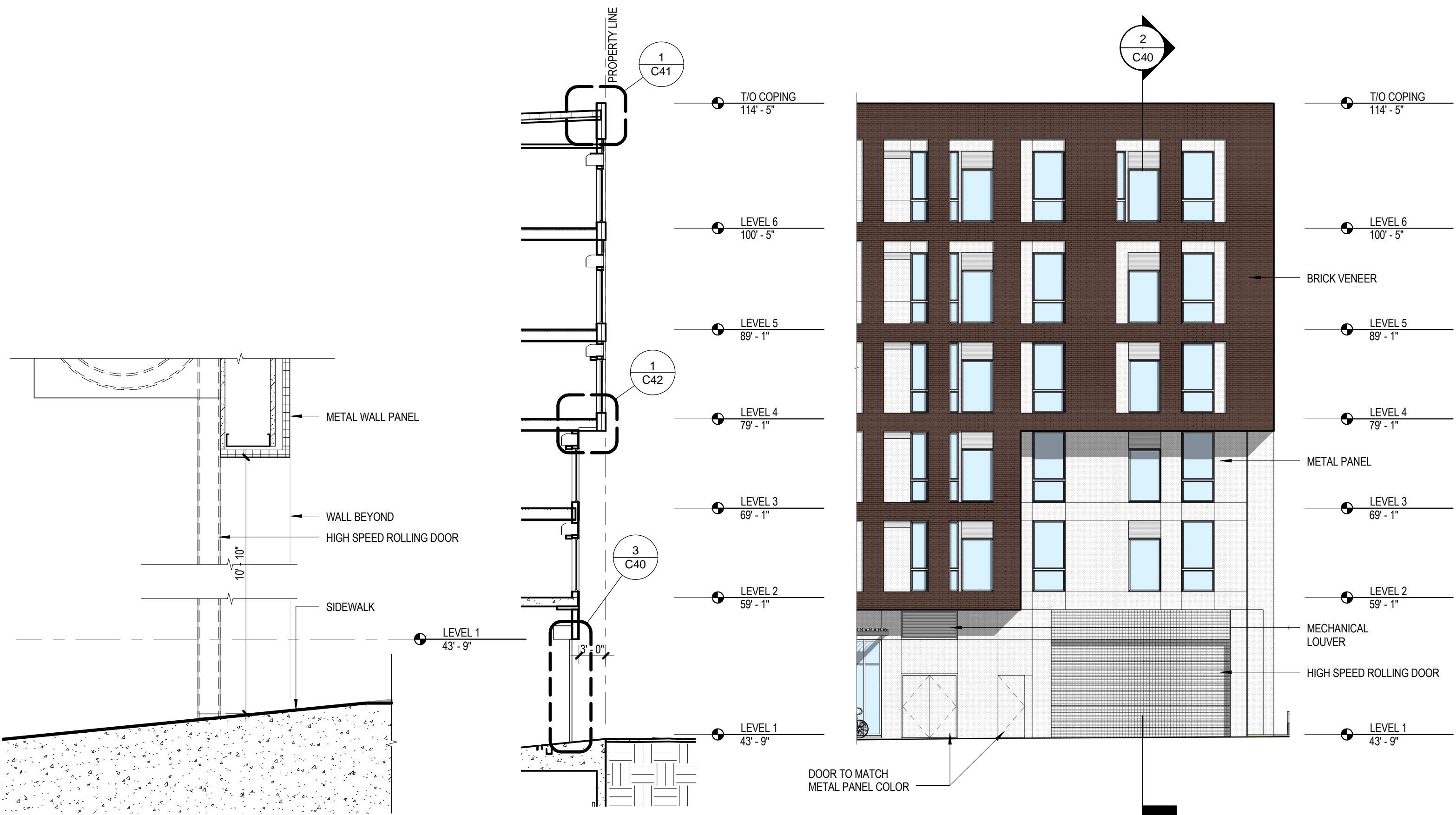

GARAGE GATE SECTION 3  
1" = 1'-0"

WALL SECTION 2

ENLARGED WEST ELEVATION 1

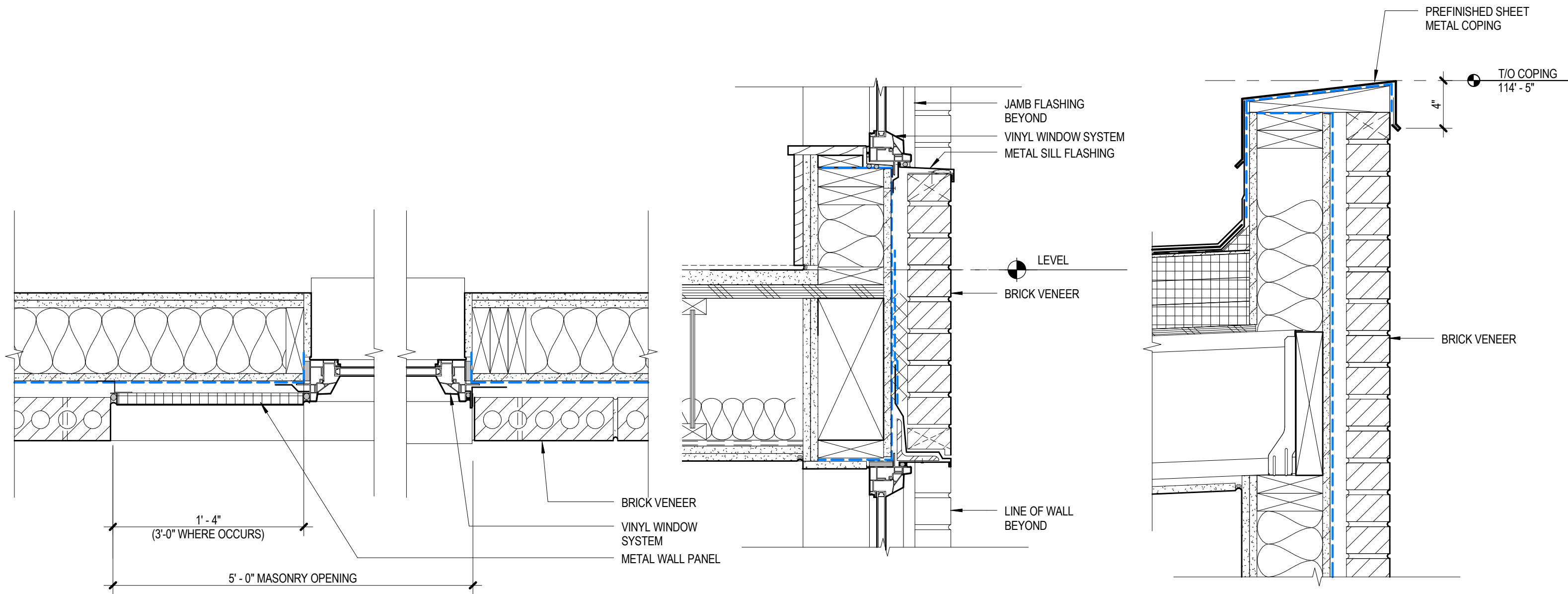

METAL PANEL TO BRICK TRANSITION  
 1 1/2" = 1'-0" ④

TYP WINDOW JAMB  
 1 1/2" = 1'-0" ③

TYP HEAD & SILL AT BRICK  
 1 1/2" = 1'-0" ②

PARAPET AT BRICK  
 1 1/2" = 1'-0" ①



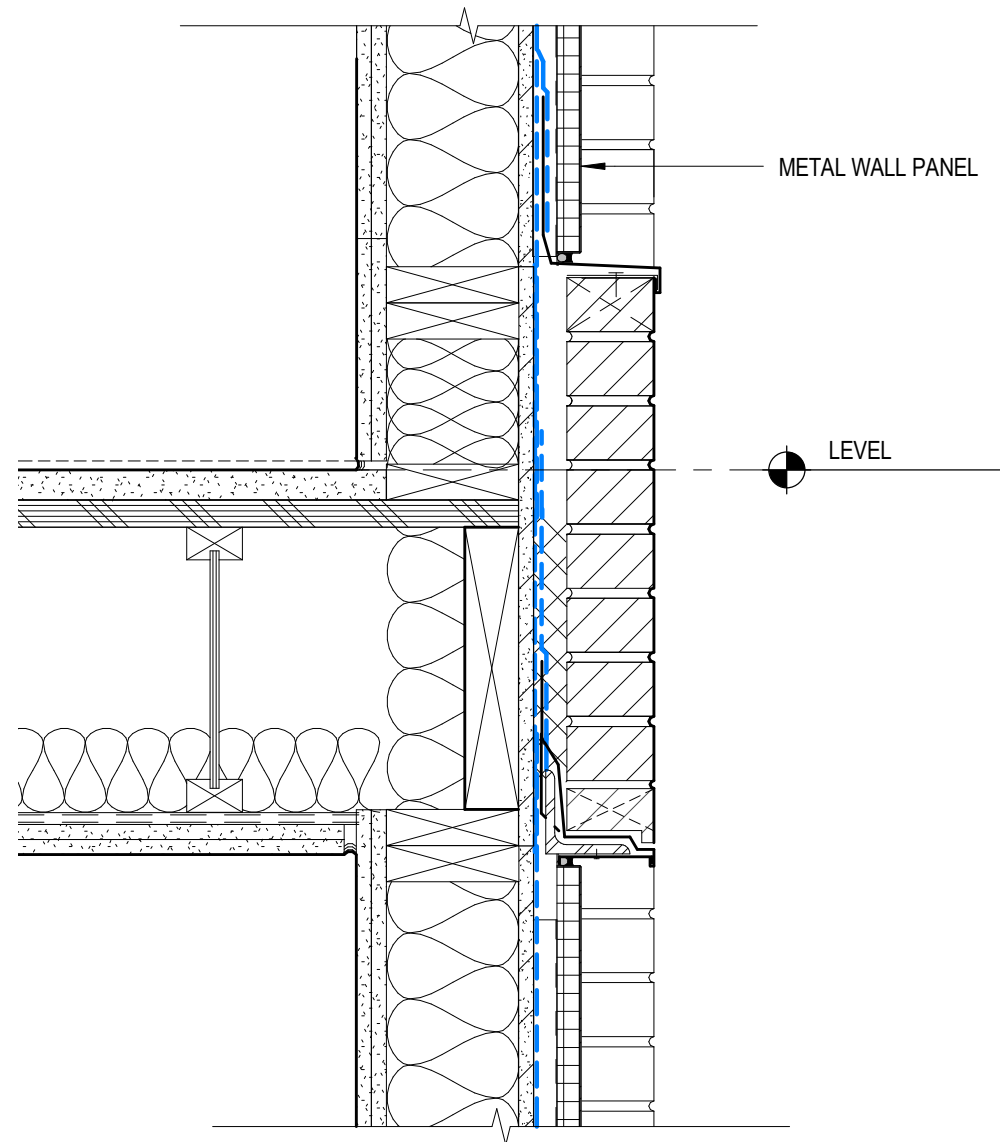

METAL PANEL HEAD/SILL AT BRICK (2)  
 1 1/2" = 1'-0"

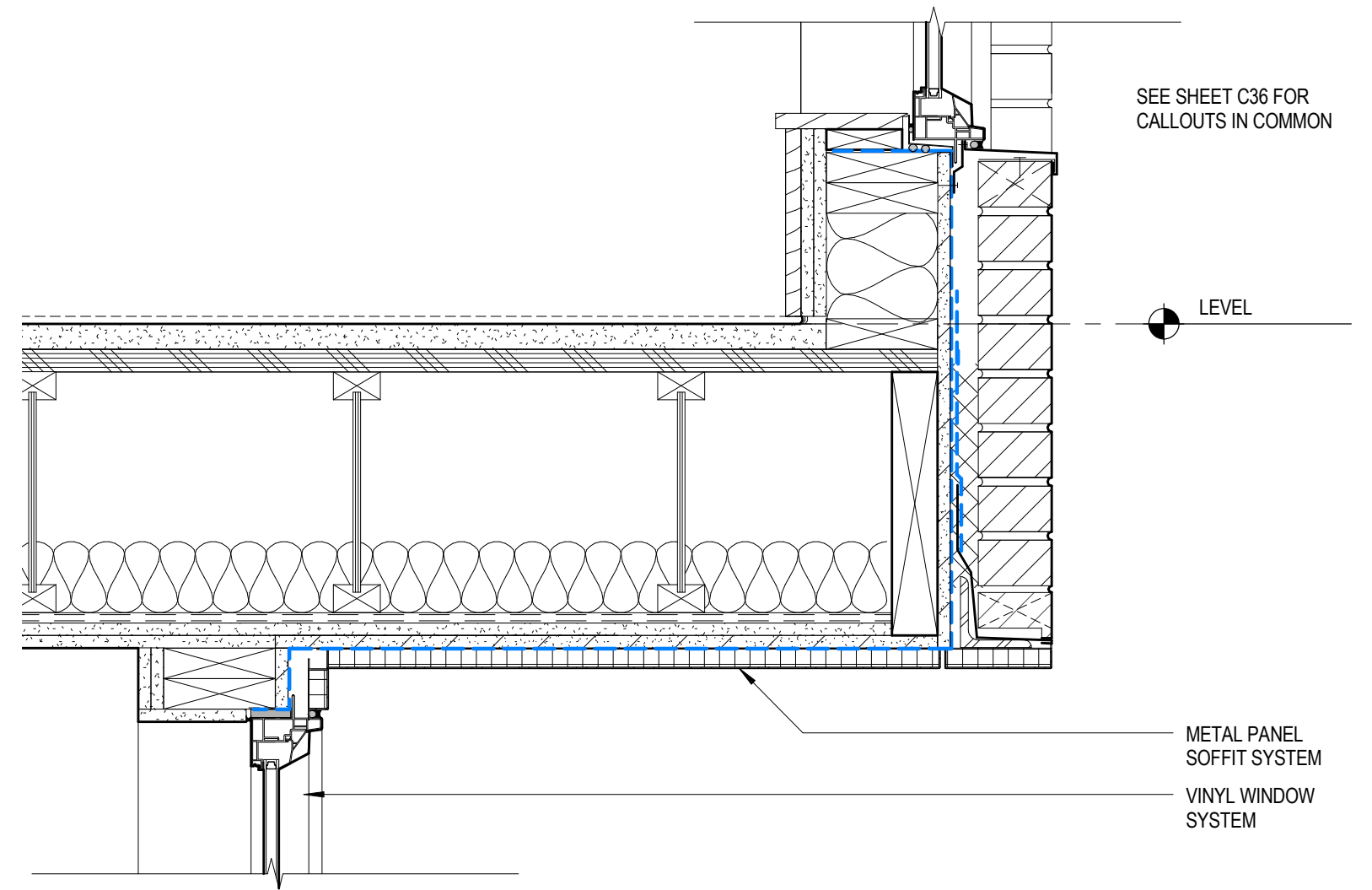

SEE SHEET C36 FOR  
 CALLOUTS IN COMMON

LEVEL

METAL PANEL  
 SOFFIT SYSTEM  
 VINYL WINDOW  
 SYSTEM

TYP SOFFIT AT BRICK (1)  
 1 1/2" = 1'-0"

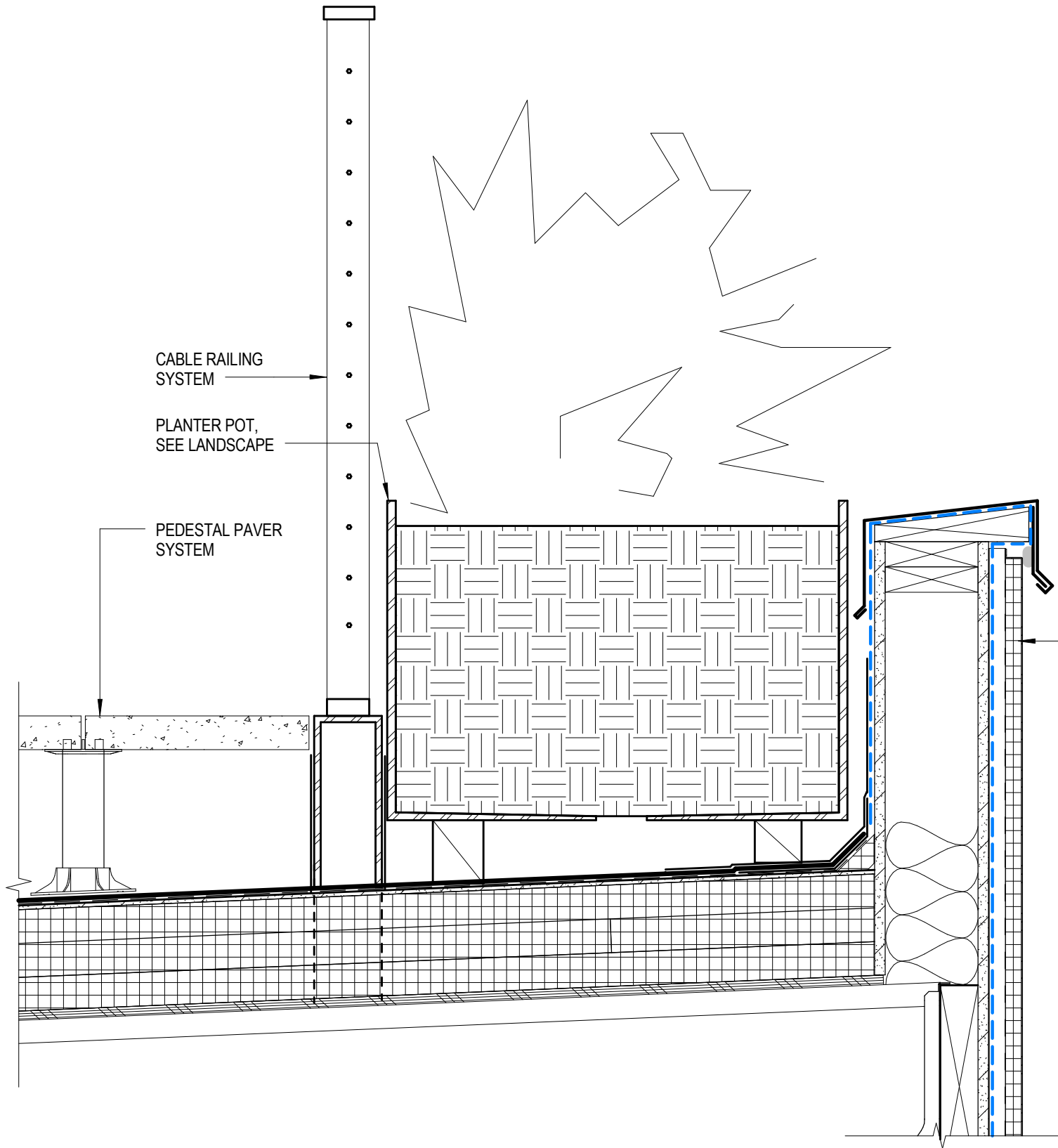

RAILING AT ROOF TERRACE ③  
1 1/2" = 1'-0"

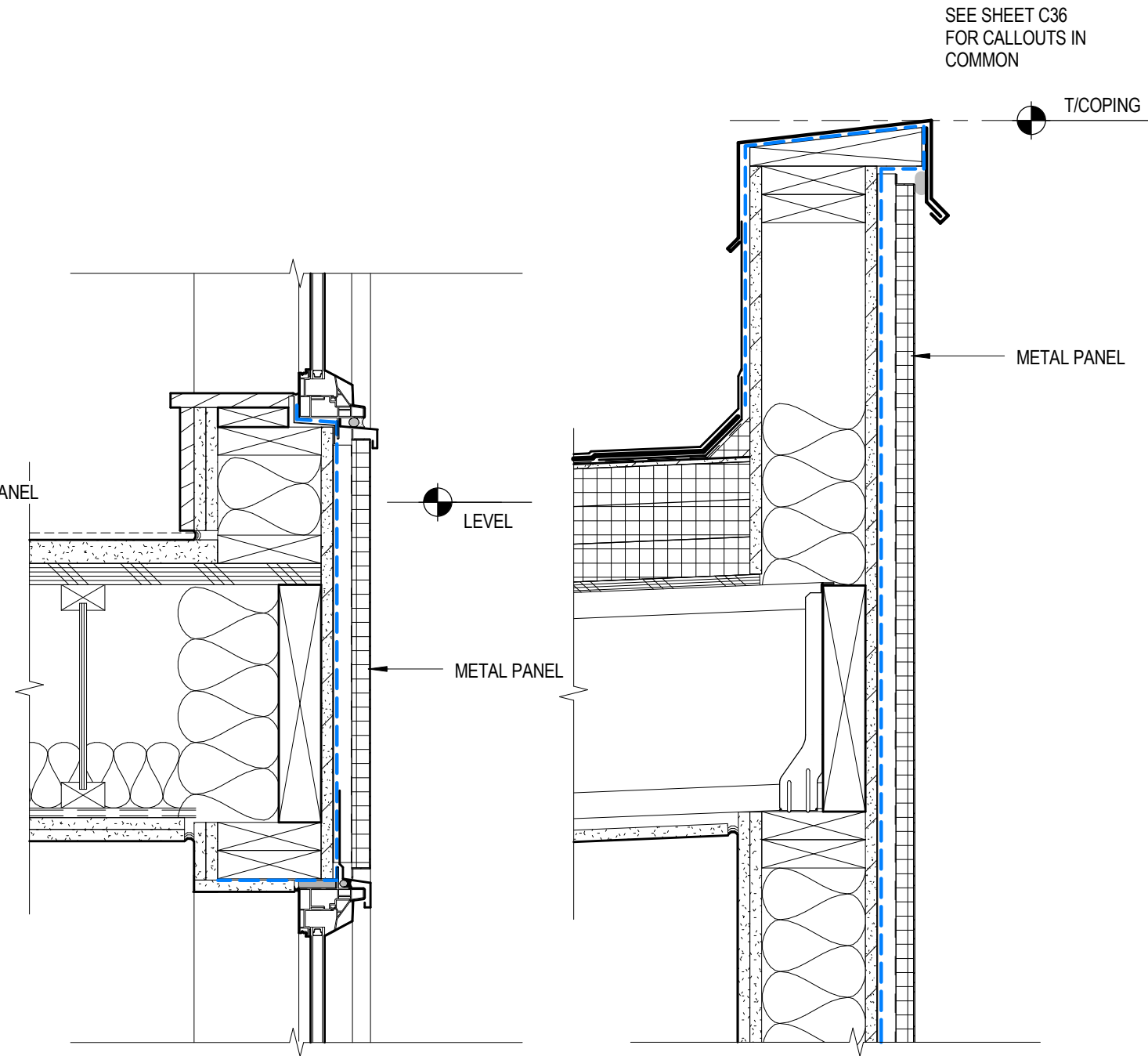

TYP HEAD & SILL AT METAL PANEL ②  
1 1/2" = 1'-0"

PARAPET AT METAL PANEL ①  
1 1/2" = 1'-0"

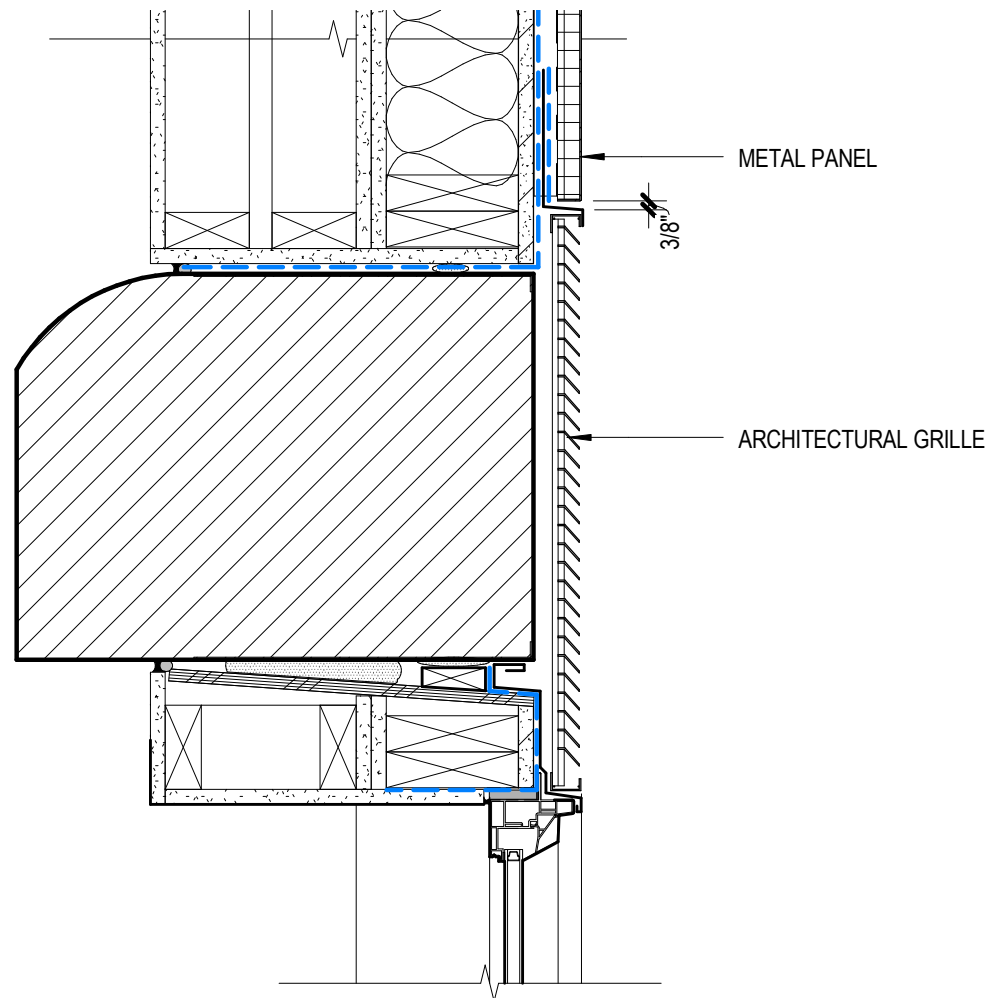

DR-HEAD AT PTHP AT METAL PANEL ②  
 1 1/2" = 1'-0"

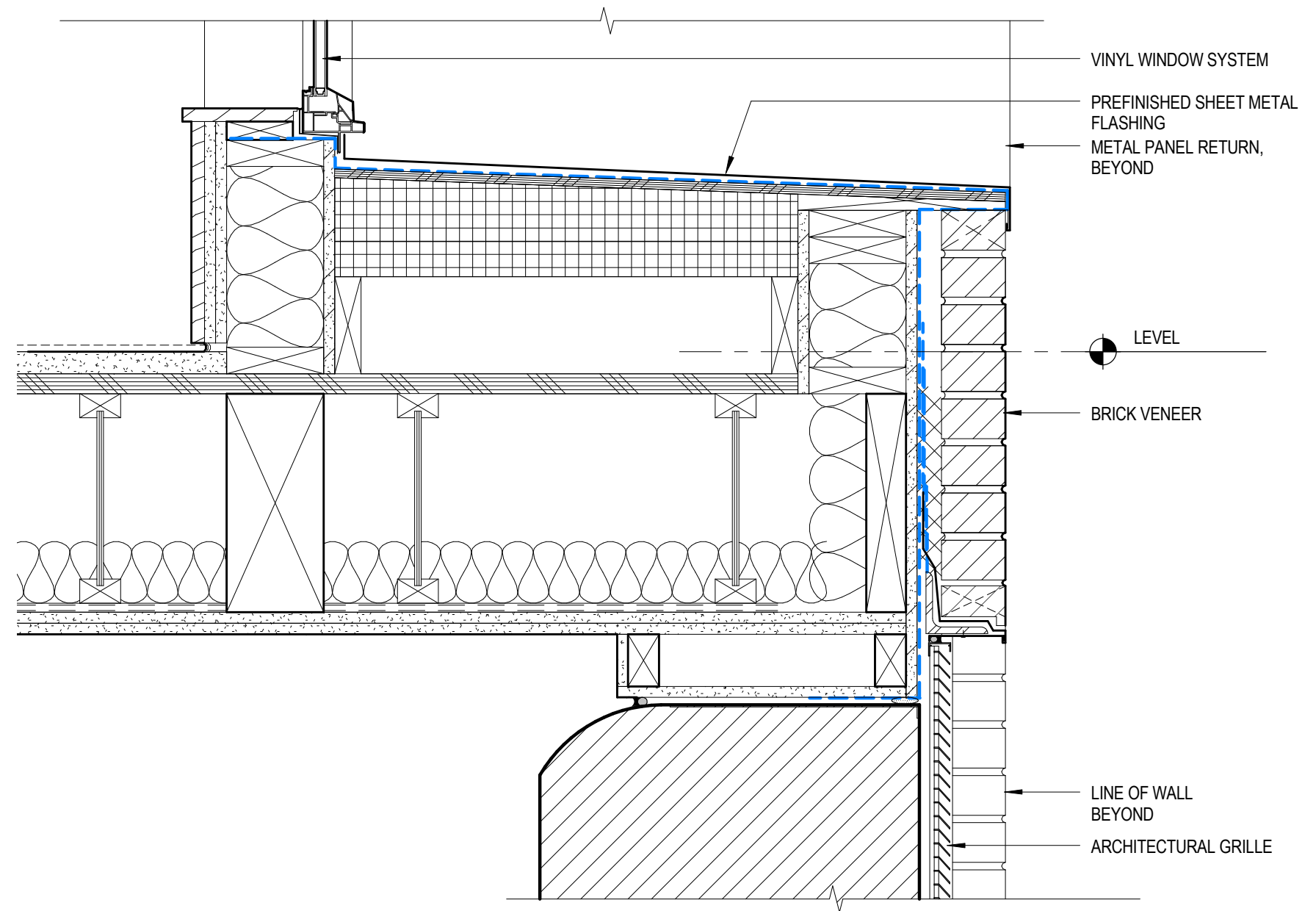

SHELF AT SETBACK ①  
 1 1/2" = 1'-0"

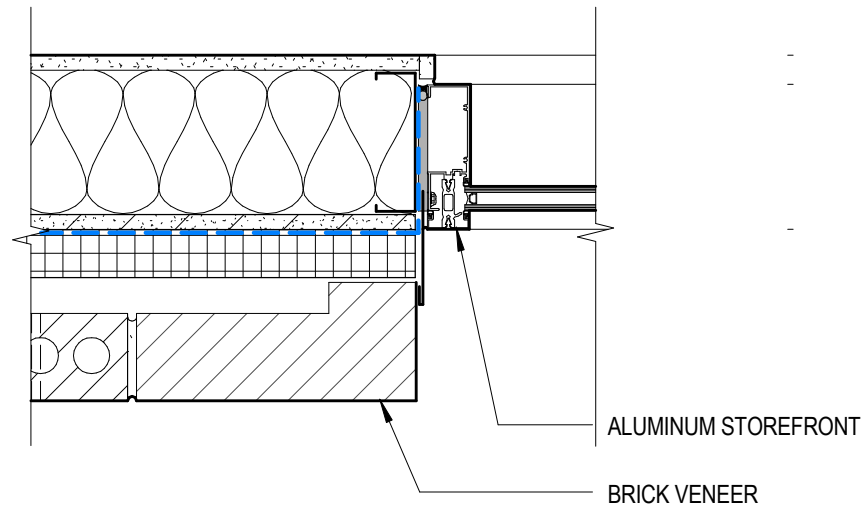

TYP STOREFRONT JAMB AT BRICK 3  
 1 1/2" = 1'-0"

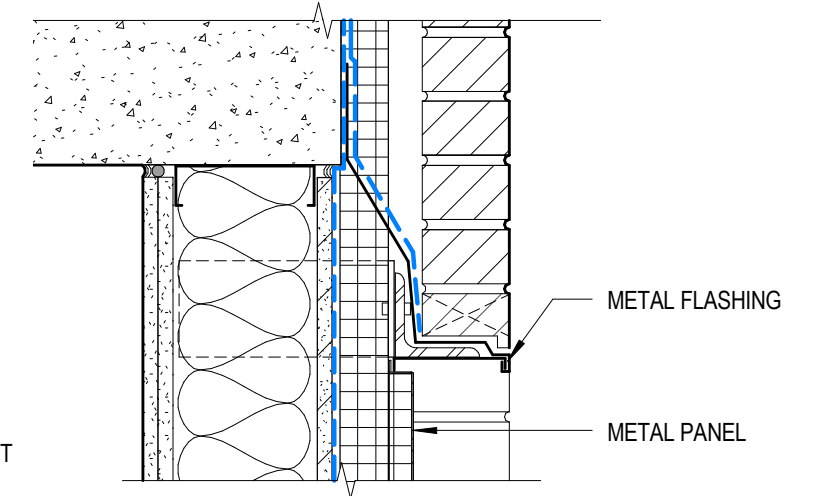

TYP STOREFRONT HEAD 1  
 1 1/2" = 1'-0"

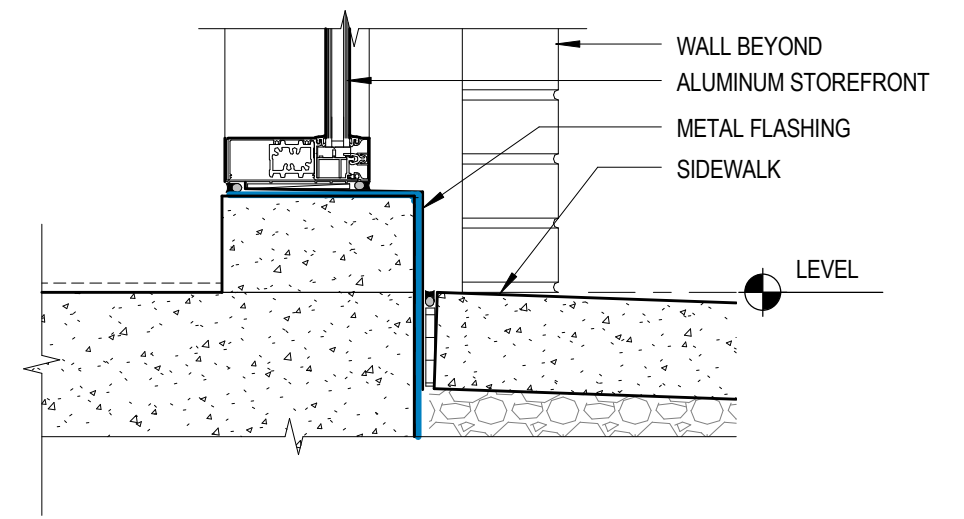
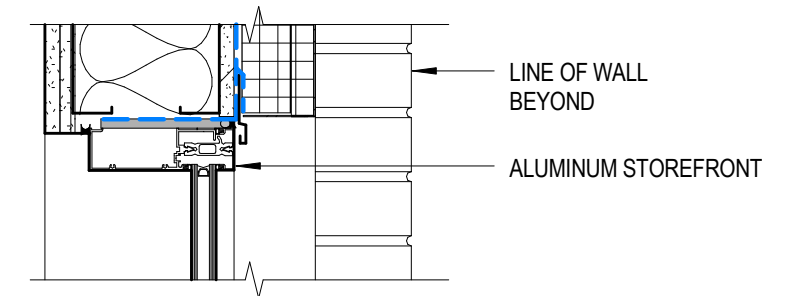

TYP STOREFRONT SILL 2  
 1 1/2" = 1'-0"

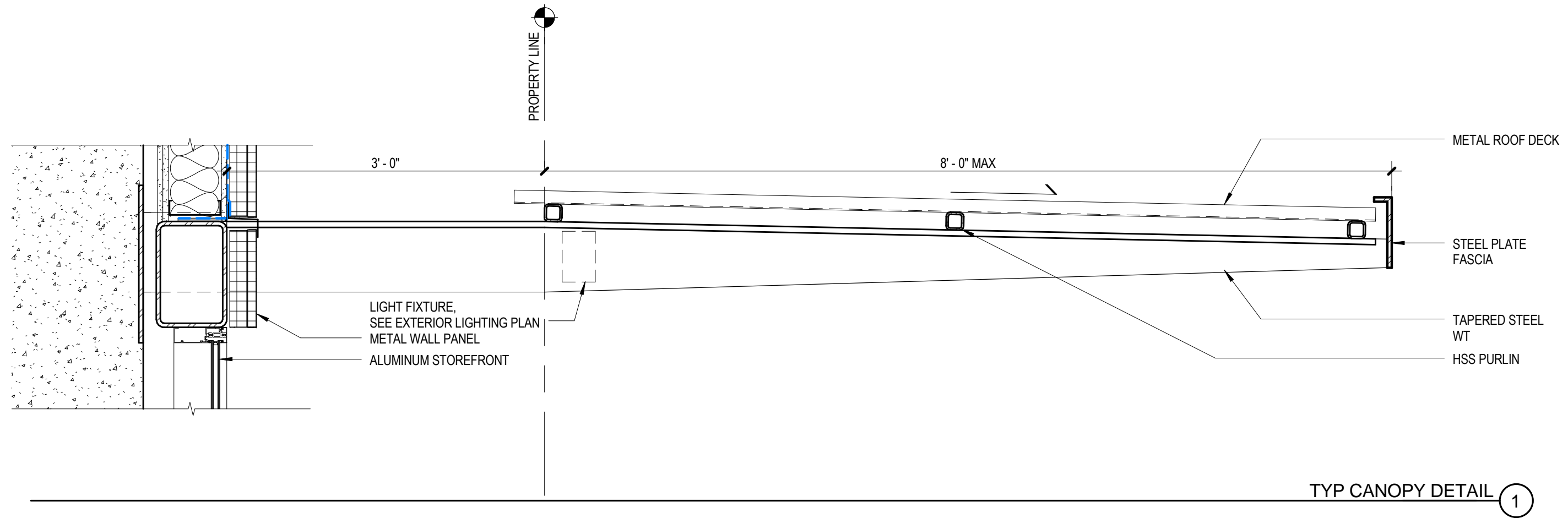

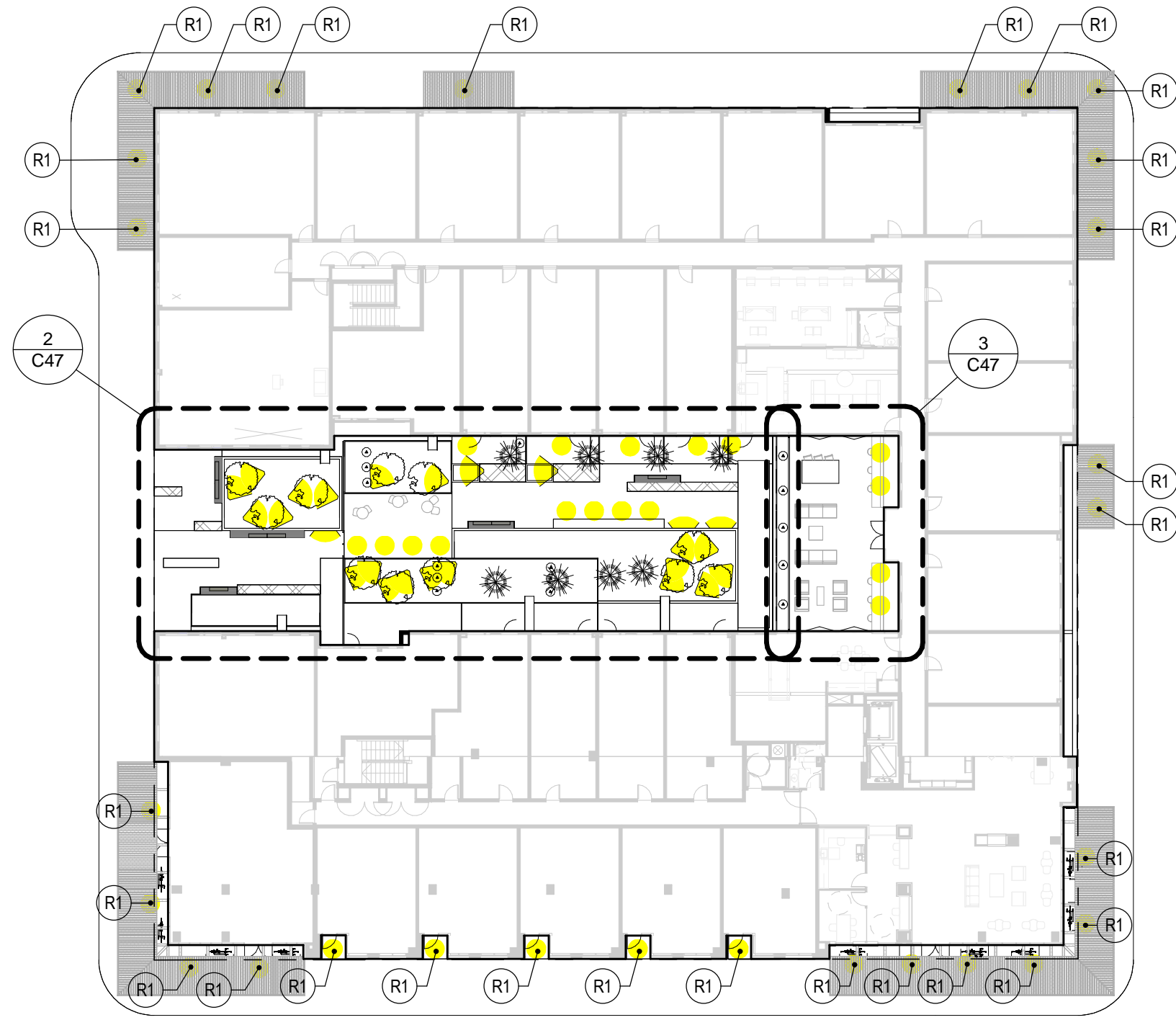
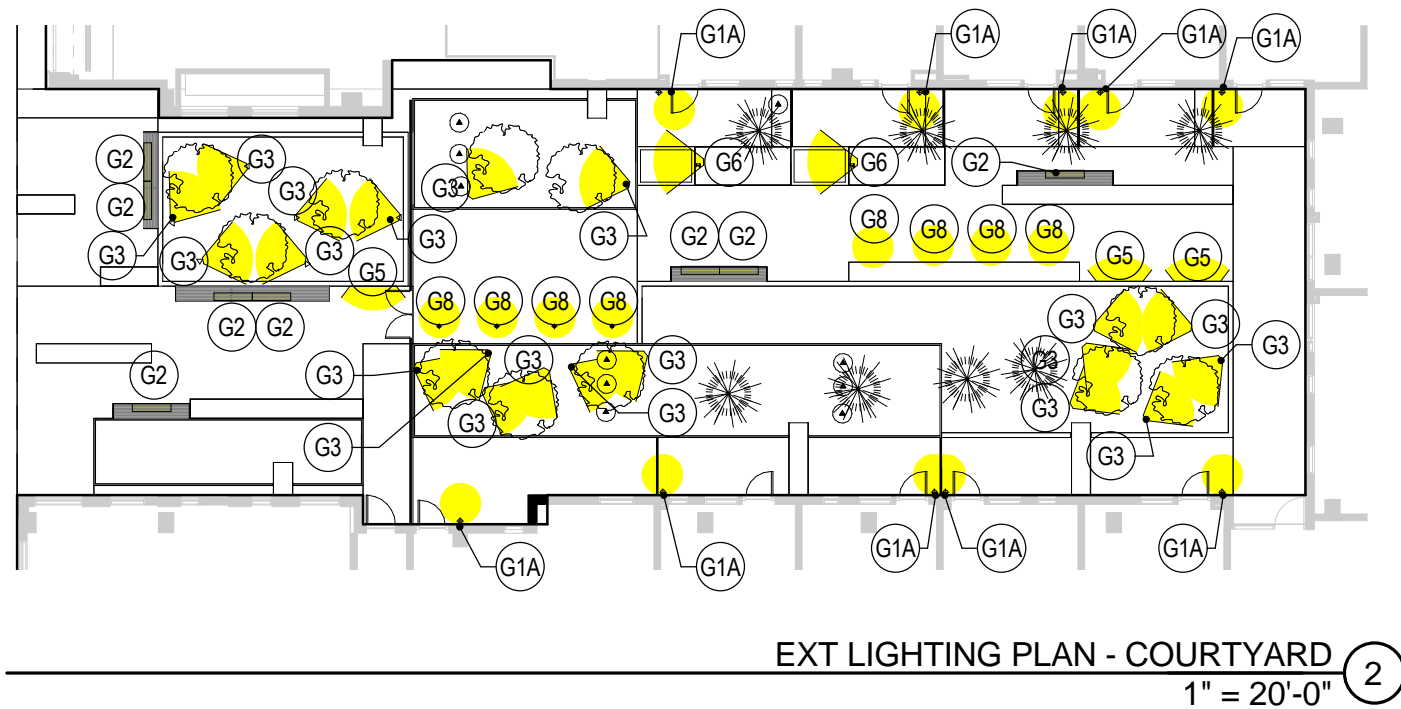

**EXTERIOR LIGHTING SCHEDULE**

FIXTURE TYPE	DESCRIPTION	COUNT
G1A	SQUARE WALL MOUNT UP/DOWNLIGHT	10
G2	SURFACE LINEAR	8
G3	LANDSCAPE UPLIGHT	20
G5	RECESSED STEP LIGHT	3
G6	WALKWAY LIGHTING IN PLANTER	2
G8	INGROUND DISC	8
R1	RECESSED SQUARE DOWNLIGHT	33

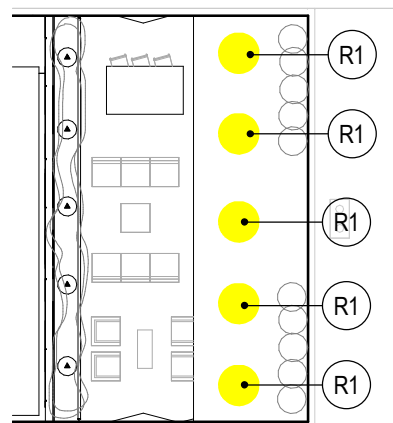

**EXT LIGHTING PLAN - ROOF TERRACE** 3  
1" = 20'-0"

**EXT LIGHTING PLAN - PERIMETER** 1  
1" = 30'-0"



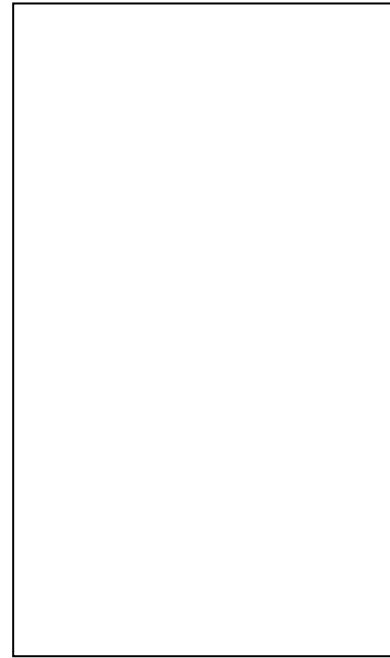

METAL PANEL - WHITE



BRICK VENEER - IRONSTONE  
NORMAN SIZE



VPI VINYL WINDOW - WHITE

PTHP LOUVER - WHITE

ALUMINUM STOREFRONT - WHITE