



**City of Portland, Oregon**  
**Bureau of Development Services**  
**Land Use Services**

FROM CONCEPT TO CONSTRUCTION

Amanda Fritz, Commissioner  
Paul L. Scarlett, Director  
Phone: (503) 823-7300  
Fax: (503) 823-5630  
TTY: (503) 823-6868  
[www.portlandoregon.gov/bds](http://www.portlandoregon.gov/bds)

**FINAL FINDINGS AND DECISION BY THE DESIGN COMMISSION**  
**RENDERED ON January 22, 2015**

**CASE FILE NUMBER: LU 14-230014 DZM AD**  
**PC # 14-134111**  
**BLOCK 136 – Mixed Use**

The Design Commission has **approved** a proposal in your neighborhood. This document is only a summary of the decision. The reasons for the decision, including the written response to the approval criteria and to public comments received on this application, are included in the version located on the BDS website <http://www.portlandonline.com/bds/index.cfm?c=46429>. Click on the District Coalition then scroll to the relevant Neighborhood, and case number. If you disagree with the decision, you can appeal. Information on how to do so is included at the end of this decision.

**BUREAU OF DEVELOPMENT SERVICES STAFF:** Jeff Mitchem 503-823-7011 / [Jeffrey.Mitchem@portlandoregon.gov](mailto:Jeffrey.Mitchem@portlandoregon.gov)

**GENERAL INFORMATION**

**Applicant/Owner:** Michael Nanney / Security Properties  
701 Fifth Ave, Suite 5700 / Seattle, WA 98101  
SP Pearl LLC  
1201 Third Ave #5400 / Seattle, Wa 98101

**Representatives:** Heidi Oien / Mithun  
1201 Alaskan Way, Ste. 200 / Seattle, WA 98101  
Karen Karlsson / KLK Consulting, LLC  
906 NW 23rd Ave / Portland, OR 97210

**Site Address:** 1241 NW JOHNSON ST

**Legal Description:** BLOCK 136 LOT 1-8, COUCHS ADD  
**Tax Account No.:** R180211770  
**State ID No.:** 1N1E33AD 01600  
**Quarter Section:** 2928

**Neighborhood:** Pearl District, contact Patricia Gardner at 503-243-2628.  
**Business District:** Pearl District Business Association, contact Adele Nofield at 503-223-0070.

**District Coalition:** Neighbors West/Northwest, contact Mark Sieber at 503-823-4212.

**Plan District:** Central City - River District

**Zoning:** EXd, Central Employment with Design Overlay

**Case Type:** DZM, Design Review with Modifications (3)  
**Procedure:** Type III, with a public hearing before the Design Commission.  
The decision of the Design Commission can be appealed to City Council.

**Proposal:**

A new full-block mixed-use project in the Central City Plan District's River sub-District. The project includes 2 north-south oriented bar buildings with a courtyard between.

**BLD #1: NW 13<sup>th</sup> Avenue Brick Building**

- 5 stories
- Maximum Allowed Height of 120', the proposed building reaches 76'-1"
  - 75' base height
  - 45' General Height Bonus (33.510.210.D.). Maximum available for 3:1 FAR – 45'.
- Approximately 15,000 square feet of retail at ground level
- Approximately 60,000 square feet of office at levels 2-5.
- Rooftop program includes roof terrace, elevator/stair overrun, mechanical enclosure and eco roof.
- An at-grade loading space will be located within the public right-of-way on the east side of NW 13<sup>th</sup> Ave immediately north of the intersection with NW Johnson St
- 13<sup>th</sup> Ave dock within the right-of-way, as allowed by the River District ROW standards – approximate dimensions: 124' long, 12'-16' deep, 3' – 4'-9" high. Single ADA ramp oriented north to NW Johnson St.
- Courtyard dock – approximate dimensions: 124' long, 8'-14' deep, 3' – 4'-9" high

**BLD #2: NW 12<sup>th</sup> Avenue Tower Building**

- 15 stories
- Maximum Allowed Height of 150', the proposed building reaches 148'-4"
  - 75' base height
  - 75' height bonuses
    - 45' General Height Bonus (33.510.210.D.). Maximum available for 3:1 FAR – 45'.
    - 30' Bonus Height Option for Housing (33.510.210.E.). Maximum available for housing – 75'.
    - If both bonus options are used, combined bonus height may not exceed 75'.
- Approximately 208 residential flats
- Total number of parking spaces proposed is 196 spaces in two levels of underground parking
- Parking and loading will be accessed from NW 12<sup>th</sup> Avenue. Three loading spaces are proposed: *Space A*. A space within the footprint of the NW 12<sup>th</sup> Ave apartment building (with access from NW 12<sup>th</sup> Ave) is 35 feet long x 11 feet 5 inches wide. *Space B*. Standard B size (18' long x 9' wide x 10' clear) located within the footprint of the NW 12<sup>th</sup> Ave apartment building (with access from NW 12<sup>th</sup> Ave). The space will be scheduled for food deliveries in the morning and generally available for office deliveries and service vehicles. *Space C*. A cargo van loading space (18' long x 10' wide x 8'-11" clear) located within the footprint of the NW 13<sup>th</sup> Ave building. Scheduled for food deliveries in the morning and available generally for office deliveries and service vehicles.

**Site FAR**

- Maximum FAR allowed for the site is 7:1, the proposed buildings combined reach approximately 6:1.
  - 4:1 base FAR (Map 510-2)
  - 3:1 FAR Residential Bonus (33.510.210.C.1.a(1)). For each square foot of housing, a bonus of 1 square foot of floor area is earned (max 3:1).

**Three (3) Modifications** are required for

1. **Rooftop Access & Mechanical (33.140.210.B.2.)** All rooftop mechanical equipment and enclosures of stairwells that provide rooftop access must be set back at least 15 feet from all roof edges that are parallel to street lot lines. Rooftop elevator mechanical equipment may extend up to 16 feet above the height limit. Stairwell enclosures, and other rooftop mechanical equipment which cumulatively covers no more than 10 percent of the roof area may extend 10 feet above the height limit. **12th Ave Building** – The rooftop mechanical enclosure is set back 13'-2" from the roof edge abutting 12<sup>th</sup> Ave and 8'-0" from the roof edge facing the courtyard. One piece of mechanical equipment is in excess of 10 feet tall (a make-up air unit at 13 feet tall.) And, the cumulative area of roof enclosures 10' above the height limit – exceeds the 10% of roof area limit. Total coverage for this building is 18.8%.
2. **Size of Loading Spaces (33.266.310.D.a.)** Two (2) Standard A loading spaces are required. A Standard A loading space must be at least 35 feet long, 10 feet wide, and have a clearance of 13 feet. The project proposes three loading spaces:
  - **Space A.** A space within the footprint of the NW 12th Ave apartment building (with access from NW 12<sup>th</sup> Ave) is 35 feet long x 11 feet 5 inches wide (except at doorway which is 10 feet wide). The height of the space, however, varies. A majority of the space (28 feet of it) is 19 feet 6 inches high with the remaining portion varying from 11 feet (at doorway) to 12 feet outside the doorway. The space will be scheduled for food deliveries in morning, resident move-in/out during the day and generally available for office deliveries.
  - **Space B.** Standard B size (18' long x 9' wide x 10' clear) located within the footprint of the NW 12<sup>th</sup> Ave apartment building (with access from NW 12<sup>th</sup> Ave). The space will be scheduled for food deliveries in the morning and generally available for office deliveries and service vehicles.
  - **Space C.** A cargo van loading space (18' long x 10' wide x 8'-11" clear) located within the footprint of the NW 13<sup>th</sup> Ave building. Scheduled for food deliveries in the morning and available generally for office deliveries and service vehicles.
3. **Modification Request #2: Bike Parking Space Dimension (33.266.220.C.3.b.)** A space 2 feet by 6 feet must be provided for each required bicycle parking space, so that a bicycle six feet long can be securely held with its frame supported so that the bicycle cannot be pushed or fall in a manner that will damage the wheels or components. The project proposes staggered vertical storage, dimensioned at 18" x 6' with a 5' walk aisle.

**Approval Criteria:**

In order to be approved, this proposal must comply with the approval criteria of Title 33, Portland Zoning Code. The applicable approval criteria are:

- River District Design Guidelines
- Central City Fundamental Design Guidelines
- 33.510.210 E.4. Bonus Height Option for Housing
- Adjustment Criteria (33.805.040) & Modification Criteria (33.825.040)

**ANALYSIS**

**Site and Vicinity:** The subject property is full 40,000 square-foot block, located in the River District, bound by NW 13<sup>th</sup> and NW 12<sup>th</sup> Avenues and by NW Johnson and NW Kearney Streets. Presently under the ownership of SP Pearl LLC, the property supports one single-storey 38,000 square-foot structure occupied by the Pacific Northwest College of Art. The building will be demolished to make way for the proposed project.

Over the past several years, the character of the neighborhood has significantly changed, providing increased opportunities for a variety of residential, diversified commercial/retail, and open space development. Starting at the north and rotating clockwise, immediately adjacent developments include the two-story Rivertech Building (office/retail), the 5-story Kearney Plaza, the 6-story Riverstone, the Johnson Street Townhomes, the Armco Building (Downtown Self Storage), 24 Hour Fitness, the Stagecraft Building (Nossa Familia Coffee, PNCA Studios), and Lovejoy Square (retail/office).

The site lies within the Northwest Triangle Pedestrian District per the Transportation System Plan. Street designations are:

- NW 13<sup>th</sup> Ave is designated a City Walkway;
- NW 12<sup>th</sup> Ave, NW Johnson St and Kearney St designated as Local Service Walkways; and,
- NW Johnson St is also designated as a City Bikeway.

The River District was established as an Urban Renewal Area in 1998, selected as such for its proximity to the core of downtown and to correct blighted conditions that had overtaken the area. It was envisioned that transit and open space improvements, as well as the introduction of dense housing and commercial opportunities would bring new life into this area while meeting the state land use planning goals. Since 2001, the River District, and in particular the Pearl District at the heart of the URA, has transformed significantly into one of Portland's densest and fastest-growing neighborhoods.

**Zoning:** The Central Employment (EX) zone allows mixed uses and is intended for areas in the center of the City that have predominantly industrial-type development. The intent of the zone is to allow industrial and commercial uses which need a central location. Residential uses are allowed, but are not intended to predominate or set development standards for other uses in the area.

The Design Overlay Zone [d] promotes the conservation, enhancement, and continued vitality of areas of the City with special scenic, architectural, or cultural value. This is achieved through the creation of design districts and applying the Design Overlay Zone as part of community planning projects, development of design guidelines for each district, and by requiring design review. In addition, design review ensures that certain types of infill development will be compatible with the neighborhood and enhance the area.

**Land Use History:** City records indicate the following land use reviews for this site:

- EA 14-134106 – Pre-application conference for the proposed project (Exhibit G-2);
- EA 14-134111 – Design Advice Request for the proposed project (Exhibit G-3);
- LU 14-217898 – Withdrawn;
- LUR 01-00379 DZ – Addition of three entry awnings;
- LUR 95-00301 DZ – Removal of overhead door and infill a 20'x60' wall and door void;
- LUR 97-01095 DZ– Interior tenant improvements;

**Agency Review:** A “Request for Response” was mailed October 16, 2014. The following Bureaus have responded with no issue or concerns:

The **Life Safety Plans Examiner** responded with preliminary Building Codes information that could affect the Land Use Review and/or future Building Permit reviews. Please see **Exhibit E-1** for additional details.

The **Site Development Section of BDS** responded with general comments related to permitting requirements. Please see **Exhibit E-2** for additional details.

The **Fire Bureau** responded with the following comment: A separate building permit is required for this proposal. All applicable Fire Code requirements shall apply at the time of permit review and development. Please contact the Fire Marshal's Office with any specific questions. Please see **Exhibit E-3** for additional details.

The **Bureau of Environmental Services** responded with the following comment: BES takes no exception to approval of this Design Review application. The proposed development will be subject to BES standards and requirements during the permit review process. Please see **Exhibit E-4** for additional details.

The **Bureau of Parks-Forestry Division** responded with general comments related to street trees. Please see **Exhibit E-5** for additional details.

The **Portland Bureau of Transportation** responded with general comments related to encroachment permitting for the loading dock on NW 13<sup>th</sup> Ave. All materials required for PBOT support were submitted, reviewed and approved prior to the January 22, 2015 hearing. Please see **Exhibit E-6** for additional details.

The **Portland Water Bureau** responded with general comments related to water service availability and facilities. Please see **Exhibit E-7** for additional details.

**Neighborhood Review:** A Notice of Proposal in Your Neighborhood was mailed on November 28, 2014. Please refer to **Exhibit F** for a list of those individuals submitting written testimony. Those individuals submitting written testimony for the three Design Advice Request Hearings were incorporated into the LU14-230014 DZM record by reference and are listed in **Exhibit H**.

**Project History:** The project was presented to the Design Commission for three Design Advice Requests – May 15, June 5 and July 24, 2014. The feedback provided by the Commissioners is contained in **Exhibit G.3**.

## **ZONING CODE APPROVAL CRITERIA**

### **Chapter 33.825 Design Review**

#### **Section 33.825.010 Purpose of Design Review**

Design review ensures that development conserves and enhances the recognized special design values of a site or area. Design review is used to ensure the conservation, enhancement, and continued vitality of the identified scenic, architectural, and cultural values of each design district or area. Design review ensures that certain types of infill development will be compatible with the neighborhood and enhance the area. Design review is also used in certain cases to review public and private projects to ensure that they are of a high design quality.

#### **Section 33.825.055 Design Review Approval Criteria**

A design review application will be approved if the review body finds the applicant to have shown that the proposal complies with the design guidelines for the area.

**Findings:** The site is designated with design overlay zoning (d), therefore the proposal requires Design Review approval. Because of the site's location, the applicable design guidelines are the Central City Fundamental Design Guidelines and River District Guidelines.

### **River District Design Guidelines and Central City Fundamental Design Guidelines**

The River District is planned to become a place that is remarkable within the region. The area is intended to grow rich with special and diverse qualities that are, or will become characteristic of Portland. Further, the River District will accommodate a significant portion of the region's population growth. The plan calls for the creation of a new community of dense neighborhoods, housing a resident population of over 15,000 people, and providing jobs, services, and recreation to this population and others. This area is intended to emphasize the joy of the river, connections to it, and create a sense of community. The goals frame the urban design direction for Central City and River District development.

The Central City Fundamental Design Guidelines and the River District Design Guidelines focus on four general categories. **(A) Portland Personality**, addresses design issues and elements that reinforce and enhance Portland's character. **(B) Pedestrian Emphasis**, addresses design issues and elements that contribute to a successful pedestrian environment. **(C) Project Design**, addresses specific building characteristics and their relationships to the public environment. **(D) Special Areas**, provides design guidelines for the four special areas of the Central City.

#### **River District Design Goals**

1. Extend the river into the community to develop a functional and symbolic relationship with the Willamette River.
2. Create a community of distinct neighborhoods that accommodates a significant part of the region's residential growth.
3. Enhance the District's character and livability by fostering attractive design and activities that give comfort, convenience, safety and pleasure to all its residents and visitors.
4. Strengthen connections within River District, and to adjacent areas.

#### **Central City Plan Design Goals**

1. Encourage urban design excellence in the Central City;
2. Integrate urban design and preservation of our heritage into the development process;
3. Enhance the character of the Central City's districts;
4. Promote the development of diversity and areas of special character within the Central City;
5. Establish an urban design relationship between the Central City's districts and the Central City as a whole;
6. Provide for a pleasant, rich and diverse pedestrian experience for pedestrians;
7. Provide for the humanization of the Central City through promotion of the arts;
8. Assist in creating a 24-hour Central City which is safe, humane and prosperous;
9. Ensure that new development is at a human scale and that it relates to the scale and desired character of its setting and the Central City as a whole.

Staff has considered all guidelines and has addressed only those guidelines considered applicable to this project.

**A1. Integrate the River.** Orient architectural and landscape elements including, but not limited to lobbies, entries, balconies, terraces, and outdoor areas to the Willamette River and greenway. Develop access ways for pedestrians that provide connections to the Willamette River and Greenway.

**A1-1. Link the River to the Community.** Link the Willamette River to the Community reinforcing the river's significance. This guideline may be accomplished by:

- a. Organizing land areas, and groupings of buildings to visually define the river's linkage to the community;

- b. Focusing and articulating roadways and pedestrian ways to emphasize the river.
  - c. Developing projects that celebrate the river, and contribute to creating centers of interest and activity that focuses on the Willamette; or
  - d. Connecting the internal areas of the District to the Willamette Greenway Trail.
- A2. Emphasize Portland Themes.** When provided, integrate Portland-related themes with the development's overall design concept.
- A3-1. Provide Convenient Pedestrian Linkages.** Provide convenient linkages throughout the River district that facilitate movement for pedestrians to and from the river, and to and from adjacent neighborhoods.
- B1. Reinforce and Enhance the Pedestrian System.** Maintain a convenient access route for pedestrian travel where a public right-of-way exists or has existed. Develop and define the different zones of a sidewalk: building frontage zone, street furniture zone, movement zone, and the curb. Develop pedestrian access routes to supplement the public right-of-way system through superblocks or other large blocks.
- C1. Enhance View Opportunities.** Orient windows, entrances, balconies and other building elements to surrounding points of interest and activity. Size and place new buildings to protect existing views and view corridors. Develop building façades that create visual connections to adjacent public spaces.
- C1-1. Increase River Opportunities.** Increase river and waterway view opportunities to emphasize the River District ambiance. This guideline may be accomplished by:
- a. Designing and locating development projects to visually link their views to the river and /or waterways.
  - b. Providing public stopping and viewing places which take advantage of views River District activities and features; or
  - c. Designing and orienting open space and landscape areas to emphasize views of the river and waterways.

**Findings for A1, A1-1, A2, A3-1, B1, C1, and C1-1:**

*Conceptually, the project (Heartwood + Seedling) relates to Portland themes in two ways: 'Heartwood' for lumber industry and 'Seedling' for Portland's natural setting and forested past. The courtyard's log-jam concept relates to Portland's history in the timber industry, and the NW 13th Ave Building's roof terrace uses a wood grain theme. Stormwater planters incorporated into the courtyard highlight the rain and natural environment unique to Portland and the Northwest.*

*The proposed two-Building development will support and enhance pedestrian activity within the public right-of-way. The ground floors of both buildings include a variety of public space-activating uses including storefront retail, office and residential lobbies and amenity space. These active, sidewalk-proximate spaces will enhance pedestrian connectivity throughout the district and reinforce connections to the Willamette River (about eight blocks north and west of the site.) The project adds a layer to the circulation hierarchy in the neighborhood by providing an on-grade, accessible public courtyard running north-south between the buildings fronting NW 12<sup>th</sup> and 13<sup>th</sup> Aves. The NW 13th Ave Brick Building contributes to the predominant loft warehouse typology in the area with a raised retail/restaurant loading dock and flexible retail/restaurant spaces that can help to activate the active, mixed-use pedestrian corridor on NW 13th Ave and can help to reinforce the sense of place of the street. The project is retaining cobblestones on NW Kearney St to maintain a pedestrian scale to the street.*

*The apartment building roof terrace and unit balconies will have river and territorial views. Many visual cues signifying river and greenway connections are evident from the abutting right-of-way including the arched span of the Fremont*

Bridge and the Union Station clock tower. These features and others like them serve as visual landmarks for the entire neighborhood. Neither building interferes with views down Johnson Street to the Union Station clock tower.

NW 13<sup>th</sup> Ave Brick Building: The roof terrace will offer views northward to the river and the Fremont Bridge, and southward to downtown and the west hills. Projecting box bays intermittently located on floors 2-5 will offer views over the courtyard below and obliquely on NW 13<sup>th</sup> Ave.

NW 12<sup>th</sup> Ave Tower Building: The roof terrace will offer views eastward (SE Portland, Mt Hood, etc.), westward (NW Portland, West Hills, etc.) and southward (central city, West Hills, etc.). The orientation of the tower puts the long walls along a north-south axis. Since river views are north and east, most of the units on three sides will all be able to enjoy at least some river view. Balconies for over one third of the units are oriented for views of the river. This orientation also maximizes sun exposure to the courtyard.

*These guidelines are met.*

**A3. Respect the Portland Block Structures.** Maintain and extend the traditional 200-foot block pattern to preserve the Central City's ratio of open space to built space. Where superblocks exist, locate public and/or private rights-of-way in a manner that reflects the 200-foot block pattern, and include landscaping and seating to enhance the pedestrian environment.

**Findings:** The project is being developed utilizing a traditional 200' by 200' block pattern, with right-of-way improvements as per adopted River District standards. The project will further enhance pedestrian connectivity by providing a mid-block connection through the courtyard between NW Johnson and Kearney Sts.

*This guideline is met.*

**A4. Use Unifying Elements.** Integrate unifying elements and/or develop new features that help unify and connect individual buildings and different areas.

**A5. Enhance, Embellish, and Identify Areas.** Enhance an area by reflecting the local character within the right-of-way. Embellish an area by integrating elements in new development that build on the area's character. Identify an area's special features or qualities by integrating them into new development.

**Findings for A4 and A5:** The project will reinforce a unified streetscape through the use of established street elements such as historic light standards, street tree spacing, and sidewalk joint patterns. The material palette continues that found in the Pearl District, and each building is unified with its immediate context. The NW 13th Ave building relates in height to the buildings in the predominantly brick historic district immediately south, while the NW 12th Ave building relates to the spine of taller buildings north of the site between NW 11th and 13th Aves where the height limit reaches 225'.

*Two-Building Identity.* While the two buildings differ in height, program, and materials, to contribute to the diversity of the Pearl, they share several unifying features – transparent storefronts, board-formed concrete base elements, painted steel canopies, galvanized railings, a similar storefront character, a common color palette and relational bays at the courtyard. The spaces are unified across the courtyard through vision glass and actives along the courtyard edges in both buildings.



*Loading Docks.* The project will include a covered retail dock along NW 13th Ave, contributing to the unique streetscape of covered loading docks along NW 13th Ave which are important symbols of the area's industrial past. The NW 13th Ave Building will use materials similar to the NW 13th Ave Historic District: brick, punched openings and light steel elements.

*Ground Floor Residential.* Townhouses along NW Johnson St and NW 12th Ave activate the street and enhance the residential character of these streets. The use of board-formed concrete, painted steel, canopies, and soft landscaping reflect the Pearl District and enhance the pedestrian experience.

*Public Character.* The public courtyard continues vital Pearl District place-making traditions such internally activated open spaces, social pocket places, anything bicycle, pervasive artistic expression, integrated landscapes and Italian pastimes such as Bocce Ball.

*These guidelines are met.*

**A5-3. Incorporate Water Features.** Incorporate water features or water design themes that enhance the quality, character, and image of the River District.

**A5-4. Integrate Works of Art.** Incorporate works of art or other special design features that increase the public enjoyment of the District.

**Findings:** While the project does not propose a water feature with running water, the design of the courtyard is based on logs moving down a river during their industrial process from trees to lumber. Stormwater planters are incorporated into the courtyard with visible overflows from rooftops. These provide buffers from the building to the public through block connection and perform critical stormwater function. Eco-roofs are planned for portions of both building's rooftops.

Given the history of the Pacific Northwest College of Art on the site, special importance is placed on incorporating art at Block 136. The project owner, Security Properties is working with PNCA on a concept plan for integrating public art by PNCA alumni. The concept plan will describe two programs for incorporating art:

- *Courtyard.* An area has been designated for art in the courtyard; and
- *Buildings.* Art will also be integrated into the buildings.

RACC-approved art is strongly encouraged, but not subject to design review.

*These guidelines are met.*

**A7. Establish and Maintain a Sense of Urban Enclosure.** Define public rights-of-way by creating and maintaining a sense of urban enclosure.

**Findings:** To continue the Pearl's sense of urban enclosure, both buildings will be built to their lot lines on all streets. The only exceptions occur where the residential building form steps back at the lower levels to create semi-public townhouse stoops at NW Johnson and 12th Avenue.

The overall form of the 13th Avenue Building is kept at 75' tall to relate to the historic fabric around it. Retail spaces at the corner of NW 13th & Johnson and

NW 13th & Kearney step with the adjacent grade to create street level urban spaces.

*This guideline is met.*

**A8. Contribute to a Vibrant Streetscape.** Integrate building setbacks with adjacent sidewalks to increase the space for potential public use. Develop visual and physical connections into buildings' active interior spaces from adjacent sidewalks. Use architectural elements such as atriums, grand entries and large ground-level windows to reveal important interior spaces and activities.

**B1-1. Provide Human Scale to Buildings along Walkways.** Provide human scale and interest to buildings along sidewalks and walkways.

**B2. Protect the Pedestrian.** Protect the pedestrian environment from vehicular movement. Develop integrated identification, sign, and sidewalk-oriented night-lighting systems that offer safety, interest, and diversity to the pedestrian. Incorporate building equipment, mechanical exhaust routing systems, and/or service areas in a manner that does not detract from the pedestrian environment.

**C7. Design Corners that Build Active Intersections.** Use design elements including, but not limited to, varying building heights, changes in façade plane, large windows, awnings, canopies, marquees, signs and pedestrian entrances to highlight building corners. Locate flexible sidewalk-level retail opportunities at building corners. Locate stairs, elevators, and other upper floor building access points toward the middle of the block.

**Findings for A8, B1-1, B2, and C7: Streetscape.** Providing a round-the-clock mix of residential, office and retail uses on the block ensures diverse human activity in the streetscape throughout the day and night. The project incorporates a variety seating options on the sidewalk and within the courtyard. The through-block connection at the courtyard provides ample opportunities for seating, gathering and people watching. The bocce court provides an active public program, as do public bicycle repair stations and ample bike parking.

The furnishing zone of the abutting streets has a mix of River District standard elements including trees, benches, bike racks and light poles separating pedestrians from cars. Existing parallel parking on NW Johnson, Kearney Sts and 12th Ave will maintain an effective separation from the pedestrian and vehicular traffic. Canopies at major building entry points will provide weather protection. Mechanical equipment is isolated from pedestrian view on the roof or penthouse levels of the buildings. No ground level mechanical equipment is proposed. The office building includes a band of louvers in the top level of the retail storefronts out of the pedestrian realm.

*Human Scale.* The design of the NW 13<sup>th</sup> Ave building will promote use of the loading dock with large folding storefront doors for direct public access into the proposed market. High-volume active ground-levels (18'-21'), deep steel canopies, folding storefront walls, and custom entry doors with custom hardware to the office lobby will provide human scale proportion adjacent to the sidewalk and raised dock. The NW Johnson and Kearney St elevations are designed to encourage the use of adjacent on-grade sidewalks by providing direct visual and physical connections to retail spaces through large windows and storefront openings. In addition, recessed ground level wall planes will enhance these spaces for spill out activity.

*Pedestrian Protection.* In the NW 12<sup>th</sup> Ave Tower, connections between the residential lobbies, units and the sidewalk are enhanced with outdoor transition

areas – large windows facing the street, and elevated stoops (2'-6") at the townhouse entries. Tall 20' ceilings and large expanses of clear glazing at the northeast corner of the residential building will allow views into the leasing office and lobby. Sensitive detailing of the townhouse transitions on 12th Avenue and Johnson Street, including low planter walls, high and low plantings, trellises and canopies at the stoops also provide human scale. The high rise also includes balconies to allow for informal surveillance of the street. Ground level building detailing, proportions, materials, interior space configuration and entries with large canopies are human scaled and will induce conditions supportive of pedestrian interest, activity and safety.

*Active Corners.* The corner of NW13th Ave and Johnson St has long been an important corner in the neighborhood with the active PNCA entry and artistic bike parking. In an effort to continue this use and energy, the NW 13th Ave dock pulls back at the corners creating spill-out potential. Both wall- and ground-mounted bike parking are provided at both corners as well as prominent retail building entries. This will induce sidewalk-level spill-out on NW Johnson and Kearney Sts.

*These guidelines are met.*

**B3. Bridge Pedestrian Obstacles.** Bridge across barriers and obstacles to pedestrian movement by connecting the pedestrian system with innovative, well-marked crossings and consistent sidewalk designs.

**Findings:** The street improvements on all frontages are consistent with the adopted street standards for the River District and will ensure a well-integrated and well-marked pedestrian system. At approximately 125' in length, both the NW 13<sup>th</sup> Ave dock and the courtyard dock are pulled back from the corners allowing for at-grade retail entries and spill-out potential. This is

*NW 13 Ave Dock.* The raised loading dock on NW 13<sup>th</sup> Ave is consistent with PBOT's street standards. A single accessible ramp will be provided at the south end of the dock orienting to the corner of SW Johnson and Kearney Sts.

*Courtyard Dock.* The courtyard between the buildings will provide a new mid-block connection between NW Johnson and Kearney Sts including a variety of features to enhance pedestrian safety, convenience and enjoyment. A single accessible ramp will be provided at the south end of the dock orienting to SW Johnson at mid-block.

*This guideline is met.*

**B4. Provide Stopping and Viewing Places.** Provide safe, comfortable places where people can stop, view, socialize and rest. Ensure that these places do not conflict with other sidewalk uses.

**Findings:** The unique street plan along NW 13<sup>th</sup> Avenue provides opportunities to create places for people to linger that are different from most other places in the downtown grid. The pervasive "loading dock" feature is included for a majority of the NW 13<sup>th</sup> Avenue block face with steps at both ends and a ramp at the south end. The courtyard between the two buildings will provide both formal and informal resting opportunities, tables and chairs, and a bocce court. Ample raised spill-out areas are provided on both sides of the NW 13<sup>th</sup> Ave Brick Building designed to accommodate retail or restaurant tenants. Canopies

proposed at all the retail storefront bays will provide protection from the elements.

*This guideline is met.*

**B6. Develop Weather Protection.** Develop integrated weather protection systems at the sidewalk-level of buildings to mitigate the effects of rain, wind, glare, shadow, reflection, and sunlight on the pedestrian environment.

**B7. Integrate Barrier-Free Design.** Integrate access systems for all people with the building's overall design concept.

**Findings for B6 and B7:** Well integrated all-weather protection is provided at all primary points of entry in both buildings and within the courtyard.

*NW 13<sup>th</sup> Brick Building.* The building includes a singular canopy covering the entire dock and canopies are provided over the north and south retail entries, as well as a glass canopy over the courtyard dock.

*NW 12<sup>th</sup> Ave Residential Building.* The 12th Avenue building has a canopy over the residential lobby entrance, and canopy/trellis combinations are provided over the townhouse entries.

The elevated docks on both the east and west sides of the 13<sup>th</sup> Ave building feature ramps to ensure accessibility for all people.

*These guidelines are met.*

**B6-1. Provide Outdoor Lighting at a Human Scale.** Provide outdoor lighting at a human scale to encourage evening pedestrian activity.

**C12. Integrate Exterior Lighting.** Integrate exterior lighting and its staging or structural components with the building's overall design concept. Use exterior lighting to highlight the building's architecture, being sensitive to its impacts on the skyline at night.

**C1-2. Integrate Signs and Awnings.** Integrate signs and awnings to be complementary and respectful of a building's architecture. This guideline may be accomplished by:

- a. Placing signs and awnings to fit with and respect a building's architecture;
- b. Avoiding large, excessively illuminated or freestanding signs that contribute to visual clutter; or
- c. Integrating with a building's design, an exterior sign program/system for flexible sidewalk level space that accommodates changing tenants.

**Findings for B6-1, C1-2, and C12:** *Lighting goals* have been established for the project in order to enhance the pedestrian environment: identify entry points; provide ambient light; accent the landscape; define building edges; and, define circulation. These goals have been achieved through a combination of pedestrian-oriented lighting strategies including downcast flood lighting in security critical areas such as interior courtyard spaces, low-level ground plane illumination, well-concealed landscape accent lighting, wall surface mounted downlighting of building faces and corners, in-grade uplighting of structural columns, and recessed linear lighting to accent ground-plane grade changes. No roof-top lighting has been specified at the roof terrace area, but the planter walls may incorporate low-level steplights to provide gentle night-time illumination. Overall, the exterior lighting approach illuminates the buildings, landscape and gathering spaces with well-concealed fixtures that will minimize light throw-back

to nearby residences.

*Signage Integration.* Signage is not proposed at this time. Therefore, guidelines relevant to signage do not apply. The applicant understands that any future signage in excess of 32 square feet will be subject to design review per Portland Zoning Code Section 33.420.041.

*These guidelines are met.*

**C2. Promote Quality and Permanence in Development.** Use design principles and building materials that promote quality and permanence.

**C4. Complement the Context of Existing Buildings.** Complement the context of existing buildings by using and adding to the local design vocabulary.

**C5. Design for Coherency.** Integrate the different building and design elements including, but not limited to, construction materials, roofs, entrances, as well as window, door, sign, and lighting systems, to achieve a coherent composition.

#### **Findings for C2, C4, and C5:**

*Quality and Permanence.* Material choices are responsive to DAR comments, especially with regard to the NW 12<sup>th</sup> Ave building – greater reference to Pearl District context, simplification of vertical striping pattern, increase ground floor volumes, etc. Primary material composition includes: board-formed concrete (in place of GFRC), composite aluminum panels and aluminum window wall proposed at the levels above. The red brick proposed for the bulk of the NW 13<sup>th</sup> Ave building adds a long-lasting, human-scale layer of texture that can be experienced by pedestrians at the ground level as well as by those observing from other vantage points. Both buildings will include high quality detailing of light, small-scale steel elements such as steel railings and canopies.

*Compliment Context.* The Pearl District is mixed in use and styles. The two proposed buildings take their cues from different eras of construction observed in the Pearl. The NW 13<sup>th</sup> Ave building complements the 13<sup>th</sup> Avenue Historic District in massing, opening proportions and material. Interpreted with modern details, the building also repeats design elements that are common to the Historic District's design vocabulary, such as a loading dock with canopy and human-scaled light steel elements like railings and canopies. The NW 12<sup>th</sup> Ave building uses elements that are common in newer high rises in the Pearl, such as subtle variation in massing, use of window wall, and the addition of balconies and roof terraces. Most importantly, the base of the building takes cues from successful adaptive reuse and new ground-related residential units in the area, such as townhouses with raised stoops, set-in windows and planting areas.

*Coherency.* Each building is a coherent composition of its own – the NW 13<sup>th</sup> Ave red brick warehouse vernacular reflecting a simply composed office over retail partie (history, heartwood) juxtaposed with the layered verticality of the NW 12<sup>th</sup> Ave building (future, seedling). As a two-building composition, they reference one another in subtle ways – unifying elements of concrete at the base of both buildings, matching metal panels on the residential and office bays, projecting metal/glass window bays on the brick building and an overlapping color palette.

*The 12th Avenue Building* expresses the lightness of a young forest, as metal panels and bays accentuate verticality. A concrete base at the townhouses anchors the building while opening the corners to the courtyard and NW 12<sup>th</sup> Ave. The window wall comes to the ground in a few areas to integrate the base

with the middle and top. Charcoal ground-level canopies and a light-colored trellis at the top of the building have similar details to unify the building, and also express a dark-to-light color scheme from bottom to top.

*The 13th Ave Building* expresses the solidity and industry of worked lumber. The building is a solid, compact composition of punched openings in brick. It contains a few inset areas—'kerf' patios and retail entries—cut into the form to open the building to the street, as well as the addition of two raised docks with canopies to anchor the solid building to the ground.

*These guidelines are met.*

**C1-1. Integrate Parking.** Design surface parking and parking garage exteriors to visually integrate with their surroundings. This guideline may be accomplished by:

- a. Designing street facing parking garages to not express the sloping floors of the interior parking;
- b. Designing the sidewalk level of parking structures to accommodate active uses, display windows, public art or other features which enhance the structure's relationship to pedestrians; or
- c. Accommodating vending booths along sidewalks adjacent to parking facilities, when active ground level uses are not possible.

**C7-1. Reduce the Impact of Residential Unit Garages on Pedestrians.** Reduce the impact on pedestrians from cars entering and exiting residential unit garages by locating garage access on alleys, and active spaces on ground floors that abut streets.

**Findings for C1-1 and C7-1:** The project provides two levels of underground parking accessed via a single garage entry from NW 12<sup>th</sup> Ave at mid-block. Ground floor uses adjacent to the garage entry are elevated townhome stoops, the enclosed trash room and a single loading bay. The remainder of the ground floor around both buildings includes active residential amenity and retail space. Because the below-grade parking is expressed at the building exterior only at the garage entry, the buildings' ground level enhances the site's relationship to pedestrians.

The garage entry is concealed with a 5-panel telescoping door set back from the property line by approximately six feet. This depth is consistent with the rhythm established by the adjacent townhome porches and effectively conceals oblique views of garage door operations by residents. The board-form concrete will return to the face of the garage doors. The depth is sufficient to allow motorists oblique visual access to the sidewalk upon exiting thereby minimizing potential conflicts with pedestrians.

*These guidelines are met.*

**C8. Differentiate the Sidewalk-Level of Buildings.** Differentiate the sidewalk-level of the building from the middle and top by using elements including, but not limited to, different exterior materials, awnings, signs, and large windows.

**C9. Develop Flexible Sidewalk-Level Spaces.** Develop flexible spaces at the sidewalk-level of buildings to accommodate a variety of active uses.

**Findings for C8 and C9:** The sidewalk level of the NW 13th Ave building is differentiated with a continuous retail storefront expression and associated canopies. The elevated docks on NW 13<sup>th</sup> Ave and the courtyard feature ample retail entries, operable wall panels, and unique steel/glass canopies.

The sidewalk level of the NW 12th Ave building is distinguished with double-height glazing (averaging approximately 18'-7") and a material unique to the ground floor (board-formed concrete). Steel canopies, plantings and wire mesh occur at the townhouse entries, while glazing comes to the ground at the residential amenity spaces facing the courtyard and the leasing area to distinguish the public nature of its use from the rest of the semi-private and private uses. Canopies at the entrances to the townhomes include glass extensions over a portion of the adjacent sidewalk offering additional all weather protection.

The NW 13th Avenue building is designed to be flexible, as tenants can be either demised east-to-west with access to both docks for each tenant, or ideally will accommodate an open market-type space. Corner retail either can be added to the larger market space (ramped internally), or can serve as smaller retail spaces. These spaces could include restaurants, retail shops or professional services in the future life of the building.

*These guidelines are met.*

**C10. Integrate Encroachments.** Size and place encroachments in the public right-of-way to visually and physically enhance the pedestrian environment. Locate permitted skybridges toward the middle of the block, and where they will be physically unobtrusive. Design skybridges to be visually level and transparent.

**Findings:** The NW 13<sup>th</sup> Ave building features a covered loading dock projecting into the right-of-way by approximately 12 feet for 125 of the building's 200 feet of frontage. This type of encroachment is characteristic of the NW 13th Avenue Historic District adjacent to the site. In addition, projecting window bays are proposed at levels 2-5 on the east façade allowing oblique views between the building's interior and the courtyard.

The NW 12<sup>th</sup> Ave building will feature a large canopy over the residential lobby entrance on NW Kearney St. Residential balconies on the south façade at levels 2-14 project over the NW Johnson St right-of-way by approximately four feet.

Though no skybridges are proposed, the canopies, balconies and projecting window bays will conspire to shape and protect the at-grade pedestrian environment, while adding visual interest and relief to upper wall planes.

*This guideline is met.*

**C11. Integrate Roofs and Use Rooftops.** Integrate roof function, shape, surface materials, and colors with the building's overall design concept. Size and place rooftop mechanical equipment, penthouses, other components, and related screening elements to enhance views of the Central City's skyline, as well as views from other buildings or vantage points. Develop rooftop terraces, gardens, and associated landscaped areas to be effective stormwater management tools.

**Findings:** Roof terraces are proposed on both buildings designed in reference to each building's overall design concept. The roof of the NW 13<sup>th</sup> Ave building is integrated into the overall 'heartwood' concept through the use of a wood grain pattern executed in different colors and textures of eco-roof. The roof of the NW 12th Ave building includes two outdoor kitchens, a fire pit, benches with river/mountain views, a large planter with trees which may be seen from elsewhere, and community gardens.

On both buildings, the mechanical equipment is organized into north and south mechanical enclosures which are integrated with stair penthouses and elevator overruns, thereby being unobtrusive when viewed from other locations. Trellises are placed over the office building's mechanical enclosures to block views of equipment from potential taller buildings to the north, improve the appearance of the otherwise non-descript enclosures and provide an interesting element to Portland's skyline. In addition, the roof of the subterranean parking garage is resolved as a landscaped, publically accessible courtyard between the two buildings.

*This guideline is met.*

## **MODIFICATIONS (33.825)**

### **33.825.040 Modifications That Will Better Meet Design Review Requirements:**

The review body may consider modification of site-related development standards, including the sign standards of Chapters 32.32 and 32.34 of the Sign Code, as part of the design review process. These modifications are done as part of design review and are not required to go through the adjustment process. Adjustments to use-related development standards (such as floor area ratios, intensity of use, size of the use, number of units, or concentration of uses) are required to go through the adjustment process. Modifications that are denied through design review may be requested as an adjustment through the adjustment process. The review body will approve requested modifications if it finds that the applicant has shown that the following approval criteria are met:

- A. **Better meets design guidelines.** The resulting development will better meet the applicable design guidelines; and
- B. **Purpose of the standard.** On balance, the proposal will be consistent with the purpose of the standard for which a modification is requested.

### **Modification Request #1: 33.140.210.B.2. Rooftop Access And Mechanical**

**Equipment** All rooftop mechanical equipment and enclosures of stairwells that provide rooftop access must be set back at least 15 feet from all roof edges that are parallel to street lot lines. Rooftop elevator mechanical equipment may extend up to 16 feet above the height limit. Stairwell enclosures, and other rooftop mechanical equipment which cumulatively covers no more than 10 percent of the roof area may extend 10 feet above the height limit. **12th Ave Building** – The rooftop mechanical enclosure is set back 13'-2" from the roof edge abutting 12<sup>th</sup> Ave and 8'-0" from the roof edge facing the courtyard. One piece of mechanical equipment is in excess of 10 feet tall (a make-up air unit at 13 feet tall.) And, the cumulative area of roof enclosures 10' above the height limit – exceeds the 10% of roof area limit. Total coverage for this building is 18.8%.

**Purpose Statement.** *The height standards work with the FAR, building setback, and building coverage standards to control the overall bulk and intensity of an area. The EG1 zone height limit is the same as the General Commercial zone because the EG1 zone often functions as a transition zone between industrial and residential or commercial zones. The EX zone height limit reflects its use in intense urban areas and the range of uses that are allowed. The other zones do not have height limits because tall buildings in these areas have traditionally not been a problem.*

*C11 Integrate Roofs and Use Rooftops. All rooftop mechanical equipment and enclosures of stairwells that provide rooftop access must be set back at least 15 feet from all roof edges that are parallel to street lot lines. Rooftop elevator mechanical*



*equipment may extend up to 16 feet above the height limit. Stairwell enclosures, and other rooftop mechanical equipment which cumulatively covers no more than 10 percent of the roof area may extend 10 feet above the height limit.*

- A. Better meets design guidelines.** *The resulting development will better meet the applicable design guidelines.*

**Findings:** The mechanical equipment is organized into north and south mechanical enclosures which are integrated with stair penthouses and elevator overruns, thereby being unobtrusive when viewed from other locations.

In an effort to create a unified building top appropriate for this prominent site, the mechanical enclosure has been integrated with the penthouse to create a singular form which serves to anchor the overall rooftop design. The resulting singular volume is enclosed with materials similar to residential floors below and further enhanced with the integrated trellis feature. The building mechanical equipment being integrated and screened in this manner will better meet the guidelines because the alternative to locate the equipment elsewhere on the building would result in a more visible, less integrated configuration. Overall, the rooftop is a nicely composed assemblage of simple landscape elements and passive gathering areas.

*Therefore this criterion is met.*

- B. Purpose of the standard.** *On balance, the proposal will be consistent with the purpose of the standard for which a modification is requested.*

**Findings:** The purpose of the design standard is to limit building rooftop mechanical equipment area to reduce clutter and preserve views. In this situation, building views have been maintained and enhanced by the integration of the mechanical equipment with the access enclosures and rooftop terrace landscape elements. Combined with screening and planted steel trellises the appearance will be unified and softened. The relatively modest increase in all dimensions will still enable the purpose of the design standard, which is to limit clutter while preserving the building's aesthetic. *Therefore this criterion is met.*

*Therefore this Modification merits approval.*

**Modification Request #2: Modification to 33.266.310.D (Loading Standards; Size of loading spaces).** Two (2) Standard A loading spaces are required. A Standard A loading space must be at least 35 feet long, 10 feet wide, and have a clearance of 13 feet. The project proposes three loading spaces of various sizes:

- **Space A.** A space within the footprint of the NW 12th Ave apartment building (with access from NW 12<sup>th</sup> Ave) is 35 feet long x 11 feet 5 inches wide (except at doorway which is 10 feet wide). The height of the space, however, varies. A majority of the space (28 feet of it) is 19 feet 6 inches high with the remaining portion varying from 11 feet (at doorway) to 12 feet outside the doorway. The space will be scheduled for food deliveries in morning, resident move-in/out during the day and generally available for office deliveries.
- **Space B.** Standard B size (18' long x 9' wide x 10' clear) located within the footprint of the NW 12<sup>th</sup> Ave apartment building (with access from NW 12<sup>th</sup> Ave). The space will be scheduled for food deliveries in the morning and generally available for office deliveries and service vehicles.
- **Space C.** A cargo van loading space (18' long x 10' wide x 8'-11" clear) located within the footprint of the NW 13<sup>th</sup> Ave building. Scheduled for food deliveries in the morning and available generally for office deliveries and service vehicles.

**Purpose Statement:** *A minimum number of loading spaces are required to ensure adequate areas for loading for larger uses and developments. These regulations ensure that the appearance of loading areas will be consistent with that of parking areas. The regulations ensure that access to and from loading facilities will not have a negative effect on the traffic safety or other transportation functions of the abutting right-of-way.*

**Standard:**

33.266.310.D: *Size of loading spaces*

- a. *Standard A: the loading space must be at least 35 feet long, 10 feet wide, and have a clearance of 13 feet.*

- A. Better meets design guidelines.** The resulting development will better meet the applicable design guidelines.

**Findings:** The applicant has provided extensive loading demand analysis to estimate the specific type, quantity and location of loading activity. The complexity of demand triggered by a multi-use building (office, residential, retail, etc.) necessitates a diverse and well-coordinated loading configuration. The sizes and locations of the three spaces are well suited to meet the project’s complex demand for service – Space A (capacity: 30’ long trucks), predominately serving residentially based tower demand; Space B (capacity: 20’ long trucks), flexible service for food and office demand; Space C (capacity: cargo vans), primary demand for smaller office deliveries and some food service.

The provision of three loading spaces (with varying dimensions) within the below-grade parking area better meets Central City Fundamental Design Guidelines *B1-1 Provide Human Scale to Buildings Along Walkways, B2: Protect the Pedestrian, B3: Bridge Pedestrian Obstacles, B4: Provide Stopping and Viewing Places, and B5: Make Plazas, Parks, and Open Space Successful.* The reason for the varying dimensions is in response to the complexity of building programming and the desire to create a uniform façade design, scaled for pedestrians at street level, as well as an aesthetically rich design facing the neighbors to the east. Artistically designed doors which are appropriately scaled, along with entry canopies denoting entry to the building, create this richness.

*Therefore this criterion is met.*

- B. Purpose of the standard.** On balance, the proposal will be consistent with the purpose of the standard for which a modification is requested.

**Findings:** The purpose statement for the Loading standard states that the appearance of loading areas should be “consistent with that of parking areas;” this is met simply by virtue of the loading space being located within the below-grade parking area, and with adequate clearance for a majority of the space. The truck loading space size is intended to ensure that trucks have adequate clearance given vehicle dimensions. Because the low average unit sizes demand smaller moving vehicles, the slight reduction in clearance is unlikely to significantly constrain loading operations. Lastly, the placement of the loading spaces below-grade greatly reduces negative effects “on the traffic safety or other transportation functions of the abutting right-of-way.” The proposal remains consistent with the purpose statement for the Loading standard. *Therefore this criterion is met.*

*This Modification therefore warrants approval.*

**Modification Request #2: Bike Parking Space Dimension (33.266.220.C.3.b.)** A space 2 feet by 6 feet must be provided for each required bicycle parking space, so that a bicycle six feet long can be securely held with its frame supported so that the bicycle cannot be pushed or fall in a manner that will damage the wheels or components. The project proposes staggered vertical storage, dimensioned at 18” x 6’ with a 5’ walk aisle.

**A. Better meets design guidelines.** The resulting development will better meet the applicable design guidelines.

**Findings:** The project includes 332 total long term bicycle parking spaces (residential and retail). Accommodating 473 bicycle parking spaces in a horizontal rack would consume considerable floor area (3,984 sf + maneuvering area). Relying upon a vertical/wall hanging bike rack is a far more efficient use of space and is identical to the parking system recently approved in other Pearl District projects. The proposed functional and space efficient system better meets the design guidelines because it eases floor plan demands and results in active uses at the street, such as commercial use, lobbies and residential units. *This criterion is met.*

**B. Purpose of the standard.** On balance, the proposal will be consistent with the purpose of the standard for which a modification is requested.

The purpose of the bike parking standards is: *(italicized)*  
“These standards ensure that required bicycle parking is designed so that bicycles may be securely locked without undue inconvenience and will be reasonably safeguarded from intentional or accidental damage.”

**Findings:** The proposed Bike Rack system is engineered to stagger bikes vertically to allow the handle bars to overlap. This allows the racks to provide the same level of service that would be provided by a standard 24” on center spacing within an 18” space. The staggered clearance between adjacent bikes and allowance for sliding hangers ease the hanging and locking of a bike. Additionally the loops, to which the bikes are hung, project out of the wall 27” to further ease hanging and locking bikes. A 5’ minimum aisle is still provided behind each bicycle rack. The rack system will be located within a secure bike storage enclosure within the parking garage. The bicycle parking system is safe and secure, located in a convenient area, and is designed to avoid initial or accidental damage to bicycles, so the proposal is consistent with the purpose statement of the bicycle parking standards. *This criterion is met.*

*This Modification therefore warrants approval.*

**HEIGHT BONUS OPTIONS**

**Section 33.510.205 & 33.510.210, Height and Floor Area and Height Bonus Options**

Base height allowed for this site is 75’. Additional height, up to a maximum of 75' over the base height, is allowed through general bonus heights and the bonus height option for housing. Both buildings are utilizing height and FAR bonuses –

**The NW 13<sup>th</sup> Ave brick building** is allowed a maximum height of 120’ (75’ base height + 45’ General Height Bonus). The proposed building reaches 76’-1”.

**The NW 12<sup>th</sup> Ave residential tower** is allowed a maximum height of 150' (75' base height + 75' height bonuses: 45' General Height Bonus (33.510.210.D.), maximum available for 3:1 FAR – 45' and 30' Bonus Height Option for Housing (33.510.210.E.), maximum available for housing – 75'. If both bonus options are used, combined bonus height may not exceed 75'. The proposed building reaches 148'-4".

*General bonus heights.*

For achieving a bonus floor area ratio of 3:1, a height bonus of 45' is earned. The project is earning bonus FAR through residential bonus and Eco-roof bonus.

*Bonus height option for housing.*

Although this subsection allows the review body to approve bonus height, the review body may also require reconfiguration of the building, including reducing its height, and may approve all, some or none of the bonus height requested, based on application of the criteria in Section 33.510.210.E.4. It is important to note that bonus height in excess of the maximum allowed through general bonus heights, above, must be used exclusively for housing, and may not be used to qualify for the residential floor area bonus option.

**Section 33.510.210.E.4, Approval Criteria.** The approval of the bonus height is made as part of the design review of the project. The bonus height may be approved if the review body finds that the applicant has shown that all of the following criteria have been met:

**A. The increased height will not violate an established view corridor;**

**Findings:** There is no established view corridor at the location of the project per the Portland Scenic Resources Protection Plan adopted March 15, 1991 (ord. # 1639577).

**B. If the site is within 500 feet of an R zone, the proposed building will not cast shadows that have significant negative impacts on dwelling units in R zoned lands;**

**Findings:** The site is not within 500 feet of an R zone.

**C. If the site is shown on Map 510-3 as eligible for the Open Space (OS) performance standard, the project must meet the performance standards of Subsection 33.510.205.E.;**

**Findings:** This criterion is not applicable because the site is not included on map 510-3 as eligible for the Open Space performance standard.

**D. If the site is on a block adjacent to the Yamhill or Skidmore Fountain/Old Town Historic Districts, the project must meet the performance standards of Subsection 33.510.205.D.;**

**Findings:** This criterion is not applicable due to the location of the project.

**E. The increased height will result in a project that better meets the applicable design guidelines; and**

**Findings:** For the reasons stated below, the project better meets the applicable Central City Fundamental and River District Design Guidelines noted in parentheses:

- The parallel bar building plan with on-grade central access is a common precedent throughout the Pearl District. The repetition of building footprint, contrasted by height and material variation, sharing a common ground plane will serve to tie the project to the immediate area [A2, A4, A5].
- The placement of the tower on the east side of the block allows the program to step down to NW 13<sup>th</sup> Ave, reflecting context scale and massing of the adjacent historic district. [A2, C3, C9].
- A lower height would likely consume more ground plane thereby yielding a less public-oriented courtyard amenity space. [A4, A5, C4].
- The central courtyard is a carefully designed amenity for public enjoyment that will be activated with ground level commercial uses connecting the courtyard to NW 13<sup>th</sup> Ave. [B4, B5, C6].
- The height and orientation of the residential tower surrounded by the lower-scale brick building reinforces the north-south view opportunity between river and downtown along NW 13<sup>th</sup> Ave. [A1, C1, C2-1].

**F. Approval of the increased height is consistent with the purposes stated in Subsection 33.510.205.A.**

**Findings:** "The maximum building heights are intended to accomplish several purposes of the Central City Plan. These include protecting views, creating a step-down of building heights to the Willamette River, limiting shadows on public open spaces, ensuring building height compatibility and step downs to historical districts, and limiting shadows from new development on residential neighborhoods in and at the edges of the Central City." [Purpose statement]

The project design is consistent with the purpose of this section as follows:

- Massing and height do not disrupt established views.
- Inherent in the maximum building heights and sites afforded height bonuses, both depicted on Map 510-3, the River Sub-district will have building heights that generally step down from freeway to river. This project is compliant with height allowances/bonuses of the River Sub-district of the Central City.
- The project does not shadow public open space (Jamison Square) anymore than would a project meeting the 45' height bonus only.
- The project steps down to NW 13<sup>th</sup> Avenue (the spine of the NW 13<sup>th</sup> Avenue Historic District to the south).
- The project is compatible with desired/allowed building heights and massing. It adds to a positive and varied skyline in this district.
- The zoning for the site, EX, allows for a variety of uses. The development in the Pearl District has typically been with a residential focus.

## **DEVELOPMENT STANDARDS**

Unless specifically required in the approval criteria listed above, this proposal does not have to meet the development standards in order to be approved during this review process. The plans submitted for a building or zoning permit must demonstrate that all development standards of Title 33 can be met, or have received an Adjustment or Modification via a land use review prior to the approval of a building or zoning permit.

## **CONCLUSIONS**

The design review process exists to promote the conservation, enhancement, and continued vitality of areas of the City with special scenic, architectural, or cultural value. The applicant has addressed all major concerns expressed by staff and designed a building that embodies the spirit intended by the applicable design guidelines, and

responds well to the natural, cultural and built context. The proposal meets, and in some cases exceeds the applicable design guidelines, and Modification and Adjustment criteria and therefore warrants approval.

## DESIGN COMMISSION DECISION

It is the decision of the Design Commission to approve Design Review for

### **BLD #1: NW 13<sup>th</sup> Avenue Brick Building**

- 5 stories
- Maximum Height 76'-1"
- Approximately 15,000 square feet of retail at ground level
- Approximately 60,000 square feet of office at levels 2-5.
- Rooftop program includes roof terrace, elevator/stair overrun, mechanical enclosure and eco roof.
- An at-grade loading space on NW 13<sup>th</sup>
- 13<sup>th</sup> Ave dock
- Courtyard dock

### **BLD #2: NW 12<sup>th</sup> Avenue Tower Building**

- 15 stories
- Maximum Height of 148'-4"
- Approximately 164,000 square feet of residential, floors 1-15.
- Approximately 208 residential flats
- Two levels of below grade parking – 196 spaces – access via NW 12<sup>th</sup> Ave

Approval of the following Modification requests:

1. **Rooftop Access & Mechanical (33.140.210.B.2.)** All rooftop mechanical equipment and enclosures of stairwells that provide rooftop access must be set back at least 15 feet from all roof edges that are parallel to street lot lines. Rooftop elevator mechanical equipment may extend up to 16 feet above the height limit. Stairwell enclosures, and other rooftop mechanical equipment which cumulatively covers no more than 10 percent of the roof area may extend 10 feet above the height limit. **12th Ave Building** – The rooftop mechanical enclosure is set back 13'-2" from the roof edge abutting 12<sup>th</sup> Ave and 8'-0" from the roof edge facing the courtyard. One piece of mechanical equipment is in excess of 10 feet tall (a make-up air unit at 13 feet tall.) And, the cumulative area of roof enclosures 10' above the height limit – exceeds the 10% of roof area limit. Total coverage for this building is 18.8%.
2. **Size of Loading Spaces (33.266.310.D.a.)** Two (2) Standard A loading spaces are required. A Standard A loading space must be at least 35 feet long, 10 feet wide, and have a clearance of 13 feet. The project proposes three loading spaces of various sizes:
  - **Space A.** A space within the footprint of the NW 12th Ave apartment building (with access from NW 12<sup>th</sup> Ave) is 35 feet long x 11 feet 5 inches wide (except at doorway which is 10 feet wide). The height of the space, however, varies. A majority of the space (28 feet of it) is 19 feet 6 inches high with the remaining portion varying from 11 feet (at doorway) to 12 feet outside the doorway. The space will be scheduled for food deliveries in morning, resident move-in/out during the day and generally available for office deliveries.

- **Space B.** Standard B size (18’ long x 9’ wide x 10’ clear) located within the footprint of the NW 12<sup>th</sup> Ave apartment building (with access from NW 12<sup>th</sup> Ave). The space will be scheduled for food deliveries in the morning and generally available for office deliveries and service vehicles.
- **Space C.** A cargo van loading space (18’ long x 10’ wide x 8’-11” clear) located within the footprint of the NW 13<sup>th</sup> Ave building. Scheduled for food deliveries in the morning and available generally for office deliveries and service vehicles.

**3. Bike Parking Space Dimension (33.266.220.C.3.b.)** A space 2 feet by 6 feet must be provided for each required bicycle parking space, so that a bicycle six feet long can be securely held with its frame supported so that the bicycle cannot be pushed or fall in a manner that will damage the wheels or components. The project proposes staggered vertical storage, dimensioned at 18” x 6’ with a 5’ walk aisle.

Approvals per Exhibits C.1, Block 136 Land Use Application Drawing Set (pages 1-155) and C.2, Block 136 – Materials & Cut Sheets (Chapter 1-7) signed, stamped, and dated January 29, 2015, subject to the following conditions:

**A.** No field changes allowed.

By:   
 \_\_\_\_\_  
 David Wark, Design Commission Chair

Application Filed: October 24, 2014  
 Decision Filed: January 23, 2015

Decision Rendered: January 22, 2015  
 Decision Mailed: February 2, 2015

**About this Decision.** This land use decision is **not a permit** for development. Permits may be required prior to any work. Contact the Development Services Center at 503-823-7310 for information about permits.

**Procedural Information.** The application for this land use review was submitted on October 24, 2014, and was determined to be complete on October 26, 2014. The application was presented at the Design Commission hearing on December 18, 2014 and continued to January 22, 2015 when it was approved.

*Zoning Code Section 33.700.080* states that Land Use Review applications are reviewed under the regulations in effect at the time the application was submitted, provided that the application is complete at the time of submittal, or complete within 180 days. Therefore this application was reviewed against the Zoning Code in effect on October 24, 2014.

*ORS 227.178* states the City must issue a final decision on Land Use Review applications within 120-days of the application being deemed complete. The 120-day review period may be waived or extended at the request of the applicant. In this case, the applicant waived the 120-day review period, as stated with Exhibit A-3.

**Some of the information contained in this report was provided by the applicant.** As required by Section 33.800.060 of the Portland Zoning Code, the burden of proof is on the applicant to show that the approval criteria are met. This report is the final decision of the Design Commission with input from other City and public agencies.

**Conditions of Approval.** This approval may be subject to a number of specific conditions, listed above. Compliance with the applicable conditions of approval must be documented in all related permit applications. Plans and drawings submitted during the permitting process must illustrate how applicable conditions of approval are met. Any project elements that are specifically required by conditions of approval must be shown on the plans, and labeled as such.

These conditions of approval run with the land, unless modified by future land use reviews. As used in the conditions, the term “applicant” includes the applicant for this land use review, any person undertaking development pursuant to this land use review, the proprietor of the use or development approved by this land use review, and the current owner and future owners of the property subject to this land use review.

**Appeal of this decision.** This decision is final unless appealed to City Council, who will hold a public hearing. Appeals must be filed by 4:30 pm on February 17, 2015 at 1900 SW Fourth Ave. Appeals can be filed at the Development Services Center Monday through Wednesday and Fridays between 8:00 am to 3:00 pm and on Thursdays between 8:00 am to 2:00 pm. After 3:00 pm Monday through Wednesday and Fridays, and after 2:00 pm on Thursdays, appeals must be submitted at the reception desk on the 5<sup>th</sup> floor. Information and assistance in filing an appeal is available from the Bureau of Development Services in the Development Services Center or the staff planner on this case. You may review the file on this case by appointment at, 1900 SW Fourth Avenue, Suite 5000, Portland, Oregon 97201. Please call the file review line at 503-823-7617 for an appointment.

If this decision is appealed, a hearing will be scheduled and you will be notified of the date and time of the hearing. The decision of City Council is final; any further appeal is to the Oregon Land Use Board of Appeals (LUBA).

Upon submission of their application, the applicant for this land use review chose to waive the 120-day time frame in which the City must render a decision. This additional time allows for any appeal of this proposal to be held as an evidentiary hearing, one in which new evidence can be submitted to City Council.

**Who can appeal:** You may appeal the decision only if you have written a letter which was received before the close of the record at the hearing or if you testified at the hearing, or if you are the property owner or applicant. Appeals must be filed within 14 days of the decision. **An appeal fee of \$5,000.00 will be charged.**

Neighborhood associations may qualify for a waiver of the appeal fee. Additional information on how to file and the deadline for filing an appeal will be included with the decision. Assistance in filing the appeal and information on fee waivers are available from the Bureau of Development Services in the Development Services Center, 1900 SW Fourth Ave., First Floor. Fee waivers for neighborhood associations require a vote of the authorized body of your association. Please see appeal form for additional information.

**Recording the final decision.**

If this Land Use Review is approved the final decision must be recorded with the Multnomah County Recorder. A few days prior to the last day to appeal, the City will mail instructions to the applicant for recording the documents associated with their final land use decision.

- A building or zoning permit will be issued only after the final decision is recorded.



The applicant, builder, or a representative may record the final decision as follows:

- By Mail: Send the two recording sheets (sent in separate mailing) and the final Land Use Review decision with a check made payable to the Multnomah County Recorder to: Multnomah County Recorder, P.O. Box 5007, Portland OR 97208. The recording fee is identified on the recording sheet. Please include a self-addressed, stamped envelope.
- In Person: Bring the two recording sheets (sent in separate mailing) and the final Land Use Review decision with a check made payable to the Multnomah County Recorder to the County Recorder's office located at 501 SE Hawthorne Boulevard, #158, Portland OR 97214. The recording fee is identified on the recording sheet.

For further information on recording, please call the County Recorder at 503-988-3034. For further information on your recording documents please call the Bureau of Development Services Land Use Services Division at 503-823-0625.

**Expiration of this approval.** An approval expires three years from the date the final decision is rendered unless a building permit has been issued, or the approved activity has begun.

Where a site has received approval for multiple developments, and a building permit is not issued for all of the approved development within three years of the date of the final decision, a new land use review will be required before a permit will be issued for the remaining development, subject to the Zoning Code in effect at that time.

**Applying for your permits.** A building permit, occupancy permit, or development permit must be obtained before carrying out this project. At the time they apply for a permit, permittees must demonstrate compliance with:

- All conditions imposed here.
- All applicable development standards, unless specifically exempted as part of this land use review.
- All requirements of the building code.
- All provisions of the Municipal Code of the City of Portland, and all other applicable ordinances, provisions and regulations of the City.

Jeffrey Mitchem  
January 29, 2014

**The Bureau of Development Services is committed to providing equal access to information and hearings. Please notify us no less than five business days prior to the event if you need special accommodations. Call 503-823-7300 (TTY 503-823-6868).**

**EXHIBITS – NOT ATTACHED UNLESS INDICATED**

- A. Applicant's Statement
  - 1. Block 136 Written Statement
  - 2. Stormwater Drainage Report
  - 3. Request for an Evidentiary Hearing and Waiver of Right to a Decision within 120 days
- B. Zoning Map (attached)
- C. Plan & Drawings
  - 1. Block 136 Land Use Application Drawing Set, Pages 1-155
  - 2. Sheet 21-Ground Level Plan (attached)
  - 3. Sheet 24-South Elevation (attached)
  - 4. Sheet 25-East Elevation (attached)
  - 5. Sheet 26-North Elevation (attached)
  - 6. Sheet 27-West Elevation (attached)
  - 7. Sheet 41-Courtyard Plan (attached)
  - 8. Block 136 – Materials & Cut Sheets (Chapter 1-7)
- D. Notification information:
  - 1. Request for response
  - 2. Posting letter sent to applicant
  - 3. Notice to be posted
  - 4. Applicant's statement certifying posting
  - 5. Mailed notice
  - 6. Mailing list
- E. Agency Responses:
  - 1. Life Safety Plans Examiner
  - 2. Site Development Section of BDS
  - 3. The Fire Bureau
  - 4. The Bureau of Environmental Services
  - 5. The Bureau of Parks-Forestry Division
  - 6. The Portland Bureau of Transportation
- F. Public Testimony
  - 1. Tim Allen, 10-22-14, Email in opposition to the project citing bulk, excessive height, traffic, visual impacts, demand for water.
  - 2. Mark Litchman, 12-09-14, Email in opposition to the project citing excessive height.
  - 3. David Moiel, MD, 12-18-14, Email in opposition to the project citing excessive height, climate impacts, cutesy rooftop garden, public process, lack of low-income housing and loss of sun, and increased parking demand and crime.
  - 4. Ann Remen-Wills, 12-22-15, Email in opposition to the project citing massing, bulk, imposing scale, lack of blending design and public process (PNDA).
- G. Other
  - 1. Original LUR Application
  - 2. Pre-Application Conference Summary Notes
  - 3. Design Advice Request Summary Notes
  - 4. Staff Report and Recommendation to the Design Commission (December 18, 2014)
  - 5. Request for Extension of 120-day Review Period with a Continuation Hearing (12/18/14)
- H. Hearing and Post Hearing Exhibits
  - 1. Staff Report and Recommendation to the Design Commission (January 22, 2015)  
12-18-14 Hearing, Public Testimony
  - 2. David Moiel, 820 NW 12<sup>th</sup> Ave. Portland, OR 97209
  - 3. Jack Rocheld, 1410 NW Kearney St. Portland, OR 97209

4. Kevin Strever, PO Box 1644 Newport, OR 97365
5. Burton Francis, Protect the Pearl, 3430 SE Belmont St. Portland, OR 97214.  
Requested that public testimony from DARs be incorporated by reference into LU14-230014 hearing. The following testimony is hereby incorporated:
  - Stiffler, 5-9-14
  - Quinn, 5-9-14
  - Anderson, 5-9-14
  - Winn, 5-11-14
  - Jaecksch, 5-12-14
  - Francis, 5-12-14
  - Drake, 5-13-14
  - McKinnis, 5-14-14
  - Backstrand, 5-14-12
  - Remen-Willis, 5-14-14
  - Moiel, 5-15-14
  - Kirby, 5-14-14
  - Wymore, 5-15-14
  - Backstrand, 6-3-14
  - Anderson, 6-5-14
  - Francis, 5-15-14, 6-2-14
  - Halliburton, 5-15-14, 6-5-14, 7-24-14
  - Schwartz, 6-4-14
  - Yeiter, 6-4-14
  - Merrick, 5-20-14
  - Luan, 6-4-14
  - Nute, 6-5-14
  - Hoang, 5-15-14
  - Cartwright, 5-15-14
  - Sutherland, 5-28-14
  - Leming, 5-27-14
  - Kirby, 5-27-14
  - Backstrand, 5-21-14
  - Virey, 5-19-14
  - Merrick, 5-19-14
  - Buck, 6-5-14
  - Gardner, 6-5-14
  - Drake, 6-5-14
  - Strand, 6-6-14
  - Haines, 6-12-14
  - Hansen, 6-23-14
  - Trout, 7-7-14
  - King, 7-7-14
  - Randall, 7-7-14
  - Remen-Willis, 7-8-14
  - Krattenmaker, 7-9-14
  - McBride, 7-10-14
  - Evans, 7-18-14
  - Jess, 7-20-14
  - Hickerson, 7-21-14
  - Yeiter, 7-21-14
  - Cartwright, 7-22-14
  - Merrick, 7-22-14
  - Beach, 7-22-14
  - Garsha, 7-23-14
  - Rocheld, 7-23-14

Garsha, 7-23-14  
Moiel, 7-23-14  
Czarnecki, 7-23-14  
Rocheld, 7-23-14  
Nallakrishnan, 7-24-14  
Gardner, 7-24-14  
Czarnecki, 7-24-14  
Rahm, 7-24-14  
Lennard, 7-24-14  
Hoang, 5-15-14 and 6-5-14  
Buck, 6-5-14  
Schwartz, 7-24-14

1-22-15 Hearing, Public Testimony

6. Seth Johnson, [roblect@hotmail.com](mailto:roblect@hotmail.com). (no address provided)

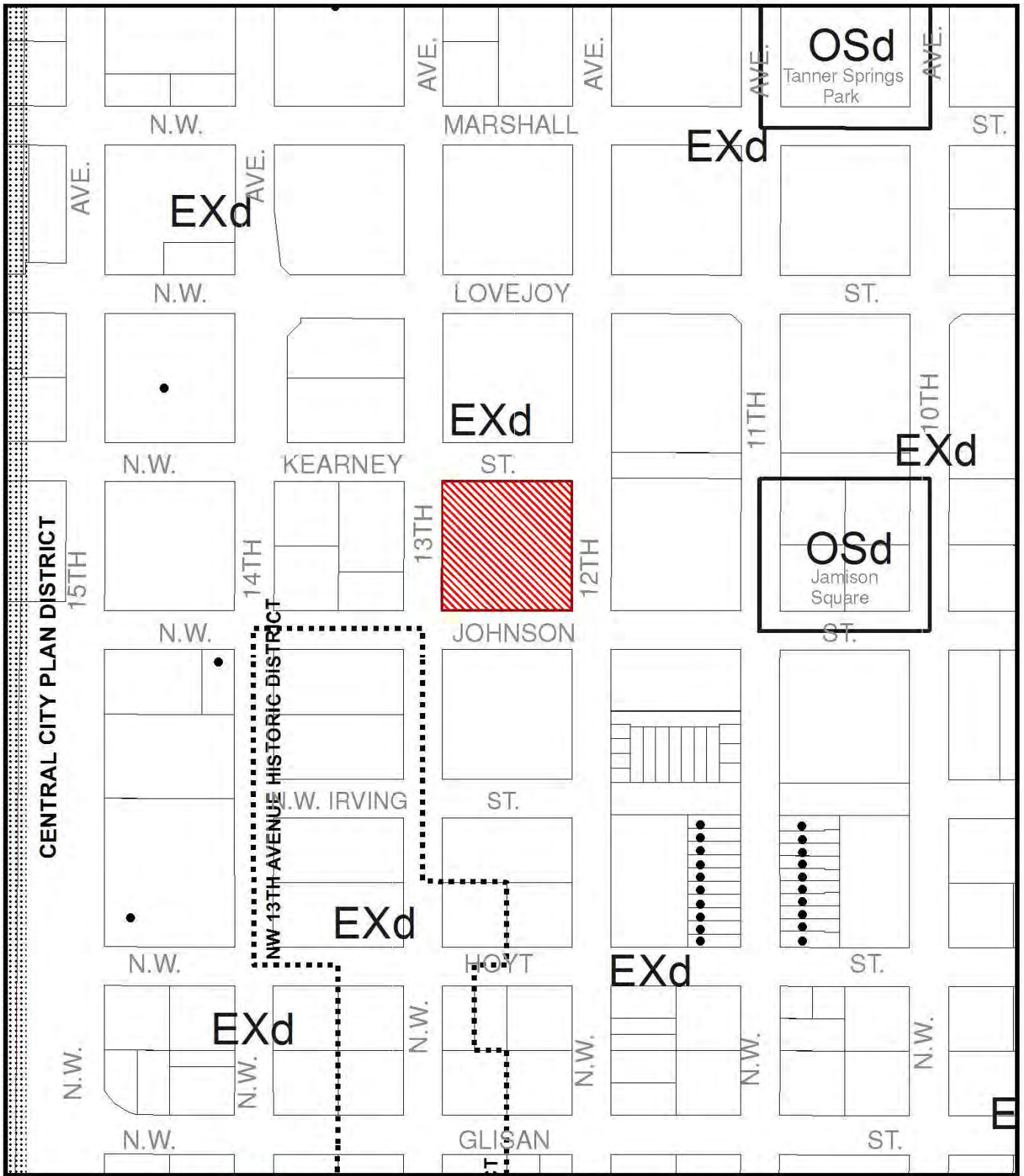

# ZONING



Site



Historic Landmark



This site lies within the:  
**CENTRAL CITY PLAN DISTRICT**  
**RIVER SUBDISTRICT**

File No. LU 14-230014 DZM, AD  
 1/4 Section 2928  
 Scale 1 inch = 200 feet  
 State\_Id 1N1E33AD 1600  
 Exhibit B (Oct 24, 2014)

# BLOCK 136

Land Use Application LU14-230014 DZM, AD

Revised January 22, 2015

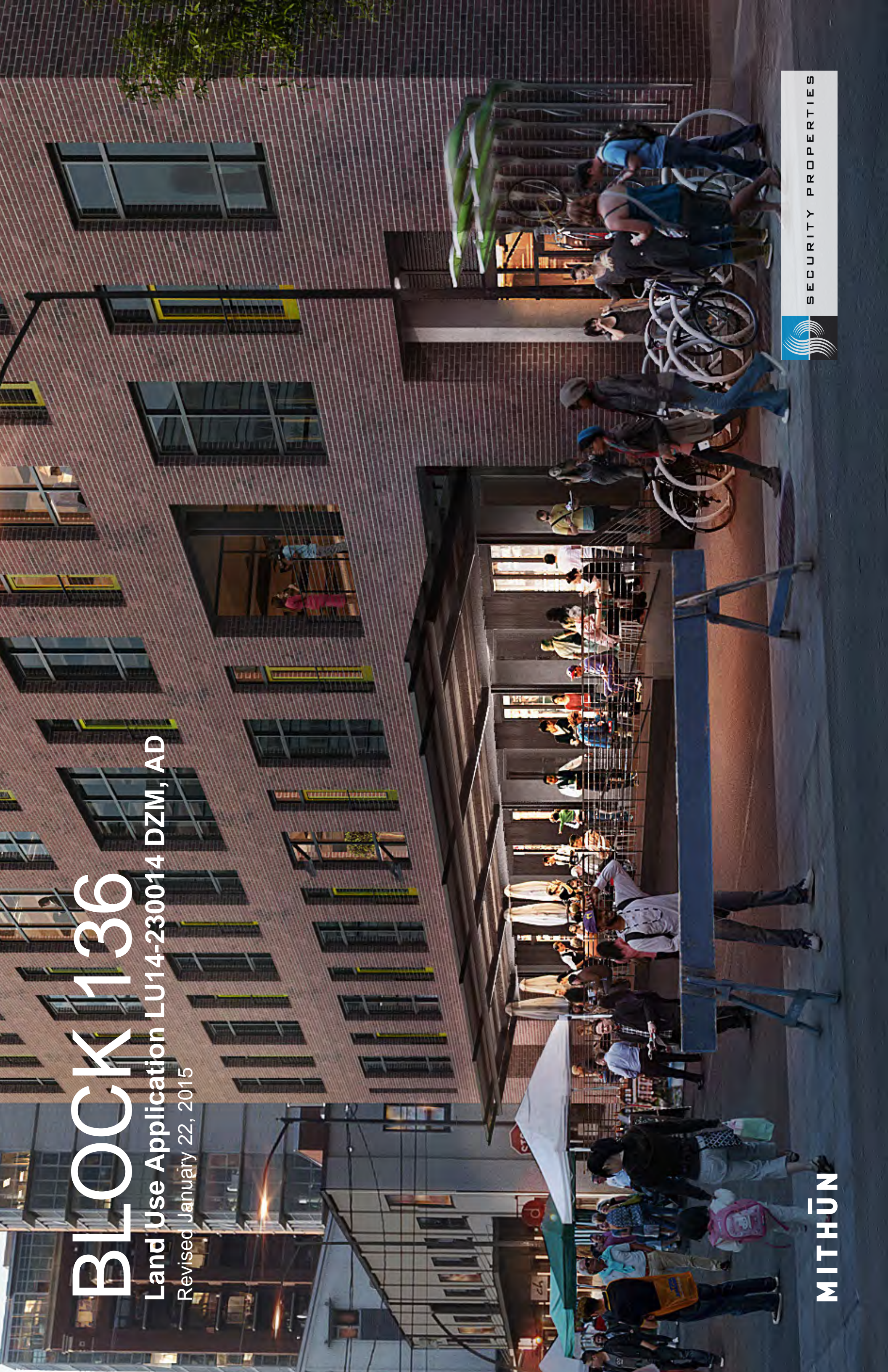

# Contents

<b>Overview</b>			
Context Map	3	<b>12th Avenue Building</b>	<b>13th Avenue Building</b>
DAR Review	3	Level 1 Plan	Ground Level Plan
Vicinity Plan	4	Level 2 Plan	Typical Office Level Plan
	8	Level 3 Plan	Roof + Mechanical Enclosure Plan
<b>Overall Project</b>		Typical Residential Level Plan	Building Section at Docks
Design Concept	15	Level 15 Penthouse Plan	Building Section at On-Grade Retail
Parking Garage Plan - Level P2	15	Roof/ Mechanical PH Plan	West Elevation at 13th Avenue
Parking Garage Plan - Level P1	18	Building Section at Window Wall Form	North & South Elevations
Bike Mezzanine Plan	19	Building Section at Townhouses	East Elevation at Courtyard
Ground Level Plan	20	Building Section at Bays	
Typical Office & Residential Plans	21	North Elevation	<b>13th Avenue Building Details</b>
Building Section Looking North	22	West Elevation at Courtyard	Dock on 13th Avenue
South Project Elevation	23	South Elevations	North + South Retail Entries
12th Avenue Building - East Elevation on 12th Avenue	24	East Elevation at 12th Avenue	Typical West Facade
North Project Elevation	25		Kerf Patio at Southwest Corner
13th Avenue Building - West Elevation on 13th Avenue	26	<b>12th Avenue Building Details</b>	Box Bays at Courtyard
13th Avenue Building - East Elevation at Courtyard	27	Townhouses (Shown at 12th Avenue)	Mechanical Penthouses & Rooftop Enclosures
12th Avenue Building - West Elevation at Courtyard	28	Garage and Loading Entries on 12th Avenue	
	29	Residential Entry	<b>13th Ave Building Roof Terrace</b>
<b>Streetscape</b>		Building Facade Elements	Plan
NW Johnson Street Plan and Elevation	31	Mechanical Penthouses	Plant Palette
NW 12th Avenue Plan and Elevation	33		
NW Kearney Street Plan and Elevation	34	<b>12th Ave Building Roof Terrace</b>	<b>Appendix A - Miscellaneous Plans</b>
NW 13th Avenue Plan and Elevation	35	Plan	Site Utility Feasibility Plan
	36	Planting Plan	Site Plan
<b>Courtyard</b>			Lighting - Fixtures
Plan	38		Lighting - Illumination Maps
Section through Bocce Court looking North	41		
Section through Seating Area looking North	44		<b>Appendix B - 30' Height Request</b>
Planting Plan	45		Floor Area Bonuses
	49		River District Zoning Base Heights
			Zoning Bonus Height Maximums
			Zoning Code Requirements

# Overview

## Context Map

### Zone + District Classifications

- Base Zone: EXd
- Land Use Classification: Central Employment (EX)
- Plan District: Central City Plan District
- District: River District, RD-2 (Core + Parking Sector)
- Design Overlay Zone: Design District (d), use River District Design Guidelines



**LEGEND**

- Block 136
- 1/4 Mile Walking Radius
- NW 13th Ave Historic District
- Bus Stop
- Streetcar Stop

**Ground Level Use**

- Retail and Service
- Residential
- Parks

**Roads/Paths**

- Pedestrian Path
- Shared Roadway
- Greenway

**Transit Lines**

- Streetcar - NS Line
- Streetcar - CL Line
- Bus Route



# Overview

## DAR Review

### What We Heard

#### Ground-level Experience

- Focus on the pedestrian experience—particularly the base of the apartment building.
- The ground floor of the apartment building is too compressed.
- The townhouse facades should be more open.
- Study and refine the garage and service entrances along 12th.
- Study whether or not the dock should extend to the corner of the 13th Avenue Building.
- Be careful that the dimensions between courtyard logs are meaningful.

#### Character

- Develop a reading of the character of the Pearl District.
- The two buildings have different material palettes—clarify what binds them together.
- Examine the character of the office building -it should look less residential.
- State the windowwall color concept and the idea behind the metal and spandrel.
- Different building expressions can work if the courtyard ties them together.

#### Additional 30' of Height

- Supportive of additional 30' of height.
- Supportive of north-south orientation.
- Supportive of having a public courtyard and office program on 13th Avenue.
- Stepping down to the river is less important than to the Historic District.

### What We Studied



Materials

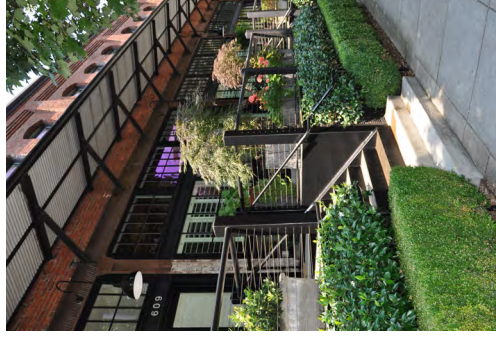
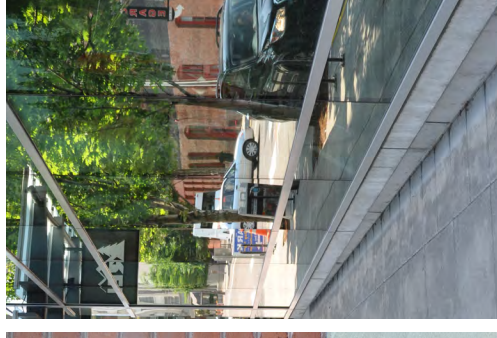

Townhouses

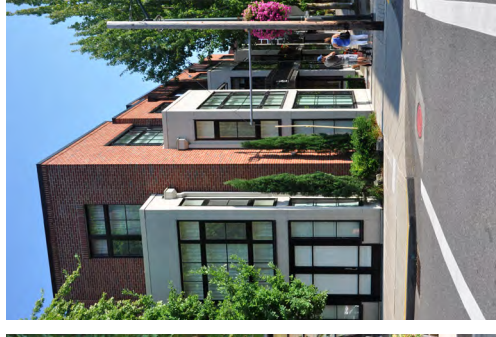
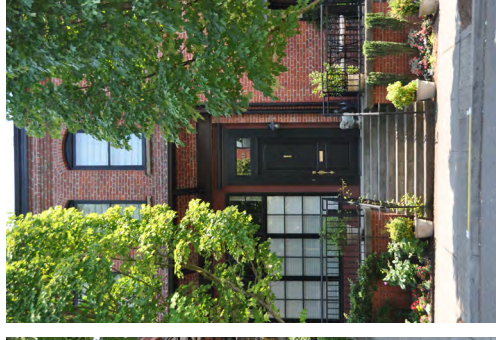

Docks

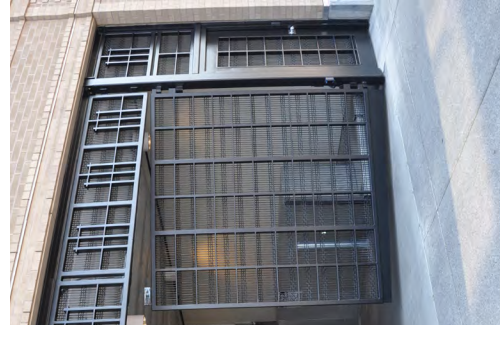
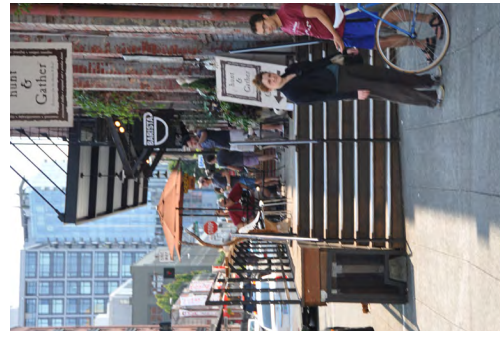

Garages

# Overview

## Contextual Analysis - River District

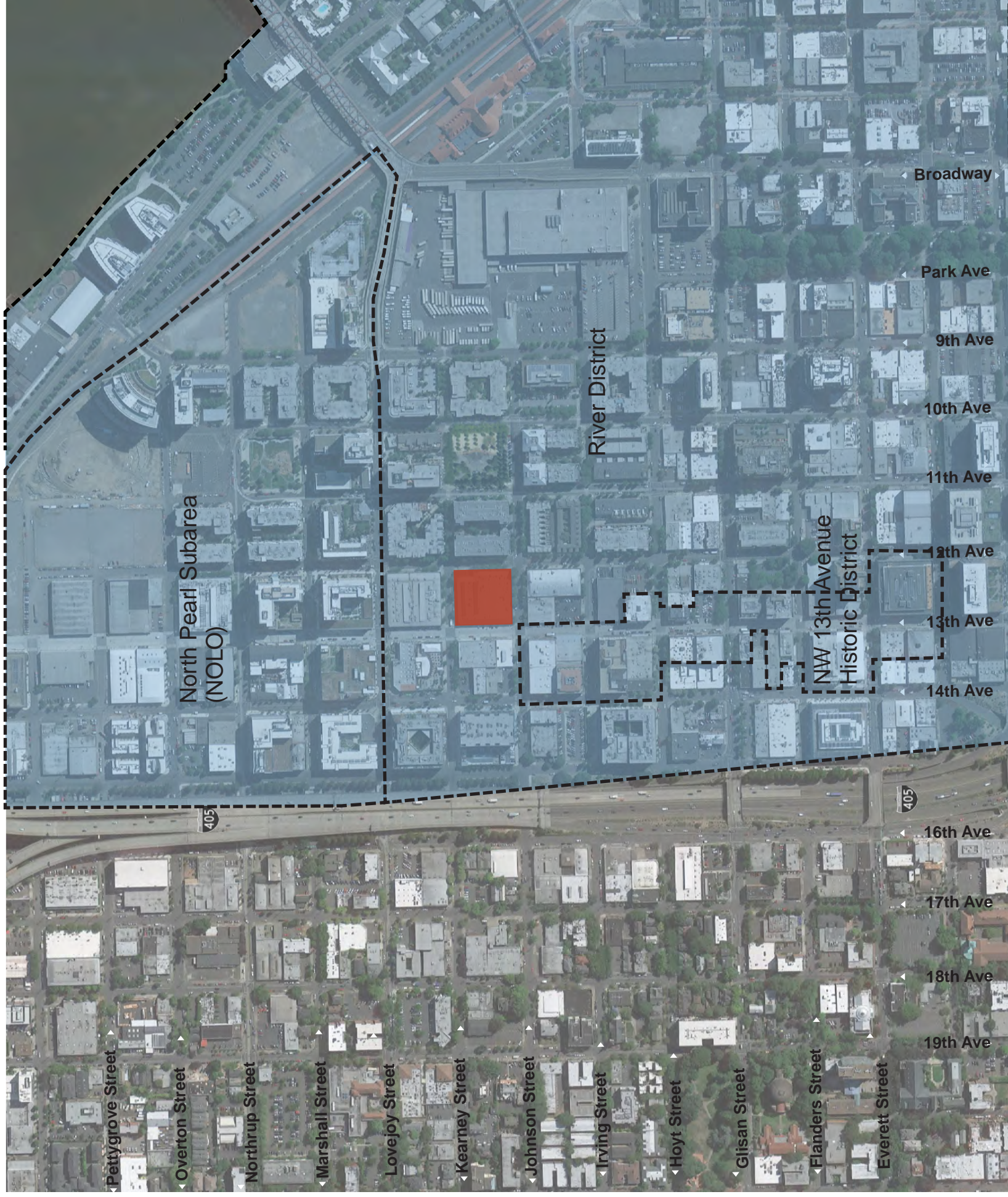

- distinct neighborhoods with unique character
- pedestrian-oriented + transit-served
- park network + river connections
- mixed use + mixed building types

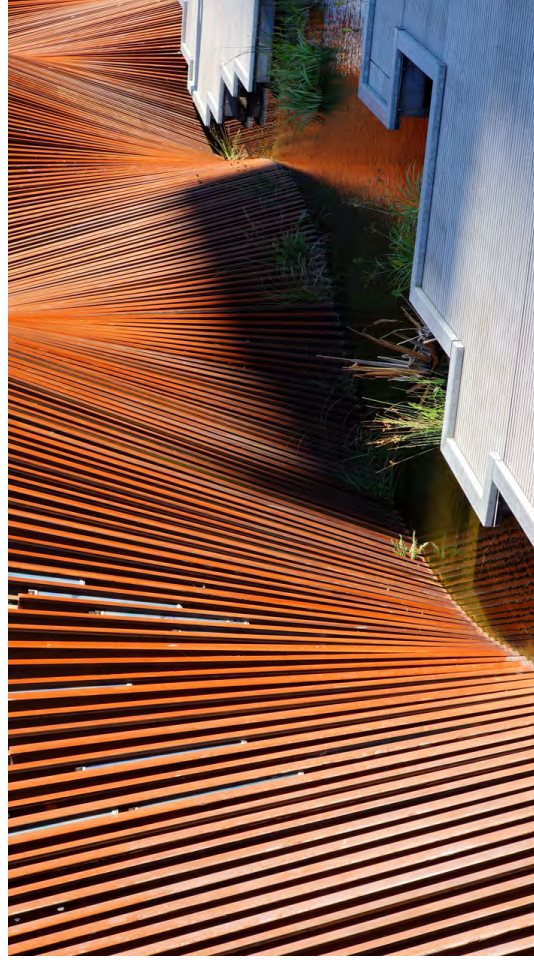

# Overview

## Contextual Analysis - NW 13th Avenue Historic District

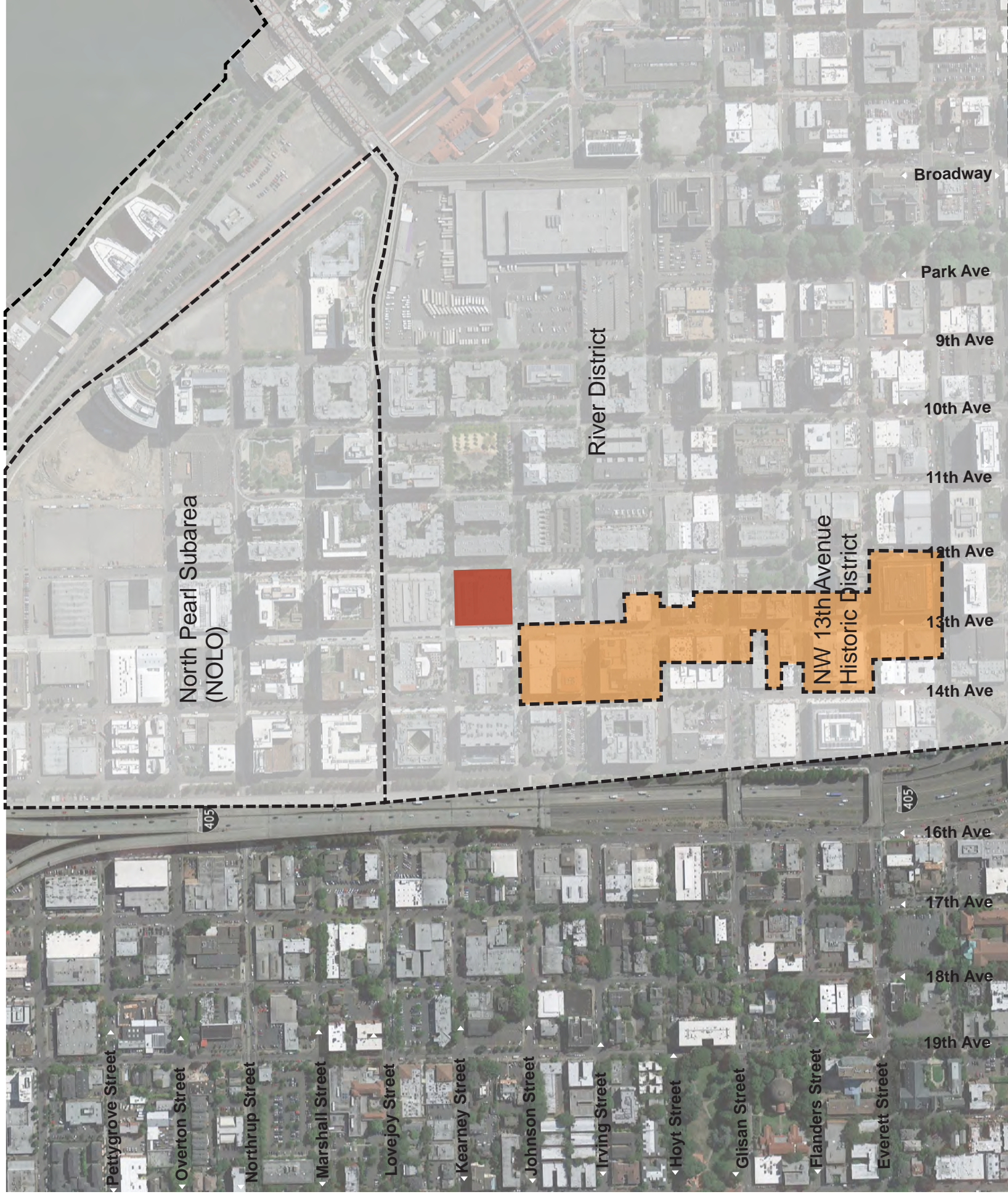

- repurposed historic buildings
- consistent building form + materials
- bearing wall masonry
- punched openings
- loading docks + canopies
- street wall enclosure
- uniform surfaces



# Overview

## Contextual Analysis - North Pearl Subarea



- newer, denser + taller
- family-focused
- great parks + openspace
- steel + glass buildings



# Overview

## Vicinity Plan



### LEGEND

- A 24 Hour Fitness
- B Mixed - Uses
- C Pearl West Office Development
- D Edge Lofts / REI
- E Mixed Uses
- F Mixed Uses
- G Mixed Uses
- H Kearney Plaza
- I Riverstone Condominiums
- J Johnson Street Townhouses
- K Jamison Square

# Overview

## Site Context

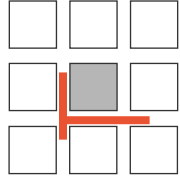

13th + Kearney

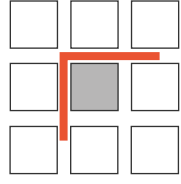

12th + Kearney

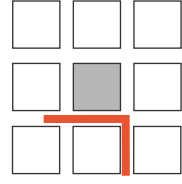

13th + Johnson



# Overview

## Site Context

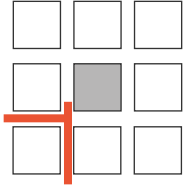

13th + Kearney

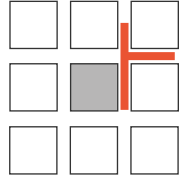

12th + Johnson

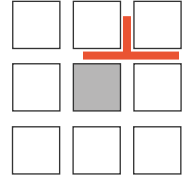

12th + Johnson

# Overview

## Site Context

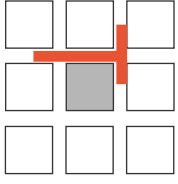

12th + Johnson

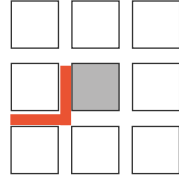

13th + Kearney

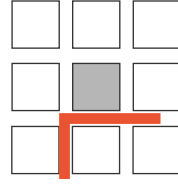

13th + Kearney



# Overview

## Pearl District Material Context

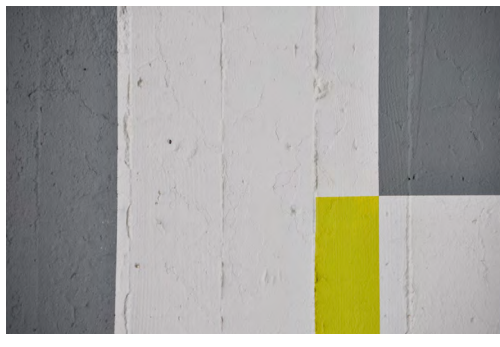
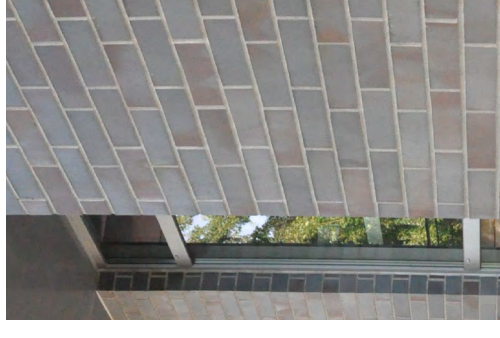
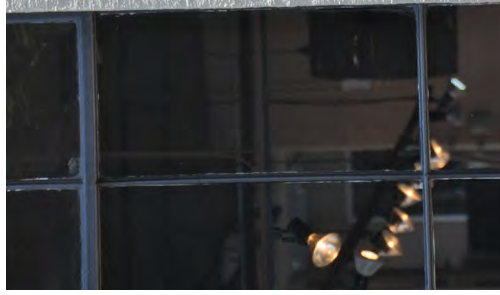
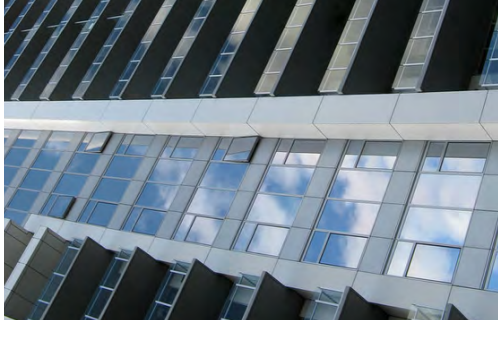
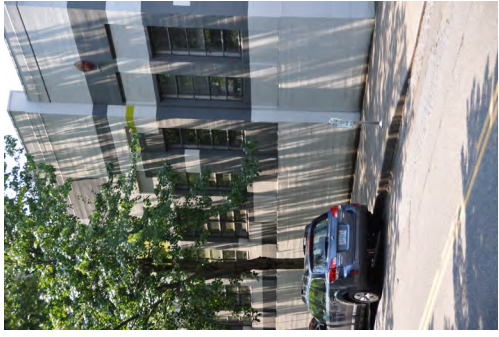
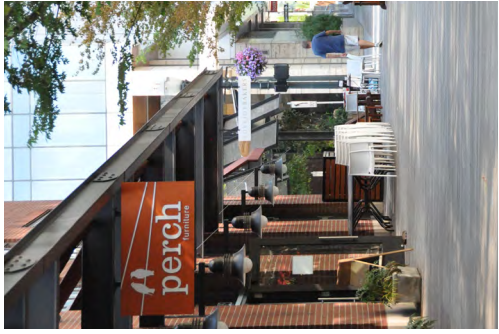

# Overview

Pearl District Neighborhood Association Meetings on 11/5/13 + 4/1/14

- 13th Avenue is critical to success of project
- Don't put height on 13th Ave
- Thru-block, at-grade pedestrian connections are desirable and fit the Pearl
- Office (especially incubator) is desirable and lacking in the Pearl
- Site needs same energy as PNCA
- Celebrate bicycles (as PNCA does)
- Retail could work in this location because of proximity to Safeway, REI, etc.
- Loading dock should be long, open on both sides and covered
- Need residential for people to age in place
- There is a need for larger residential units
- Loading is appropriate on 13th Avenue



# Overview

## Project Goals

- Fit the Pearl District
- Embraced by Community
- Provide Public Court / Mews
- Activate 13th Avenue
- Dock Sets the Tone
- Dynamic Marketplace Retail
- Residential Tower to Height Limit
- Creative Workspace Lofts
- Visible Sustainability



# Overall Project

## Design Concept

### Seedling

*a young plant or tree grown from a seed*

Live  
Habitat  
Delicate  
Unfolding  
Fresh  
Future  
Light  
Dynamic

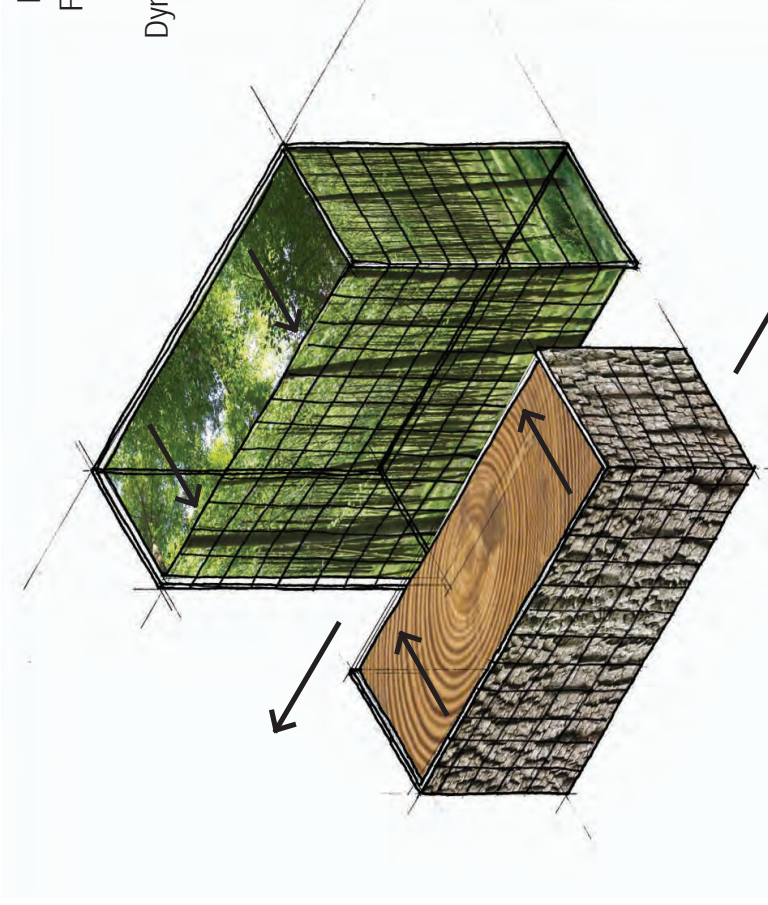

### Heartwood

*the dense inner part of a tree trunk, yielding the hardest timber*

Work  
Layers  
Heavy  
Solid  
History  
Durable  
Massive  
Processed



# Overall Project

Project View from Southwest



# Overall Project

Project View from Southwest



# Overall Project

## Parking Garage Plan - Level P2

### Parking Count

Level P1:	114'
Level P2:	82'
<b>Total:</b>	<b>196'</b>

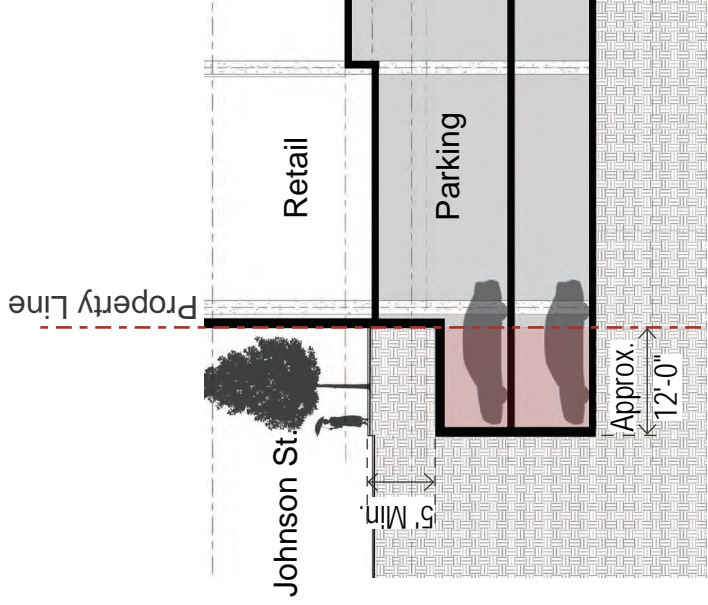

**A** Right-of-Way Parking

# Overall Project

## Parking Garage Plan - Level P1

### Parking Count

Level P1:	114'
Level P2:	82'
<b>Total:</b>	<b>196'</b>

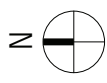



# Overall Project

## Bike Mezzanine Plan

### Bicycle Count

Mezzanine: 332'



# Overall Project

## Ground Level Plan

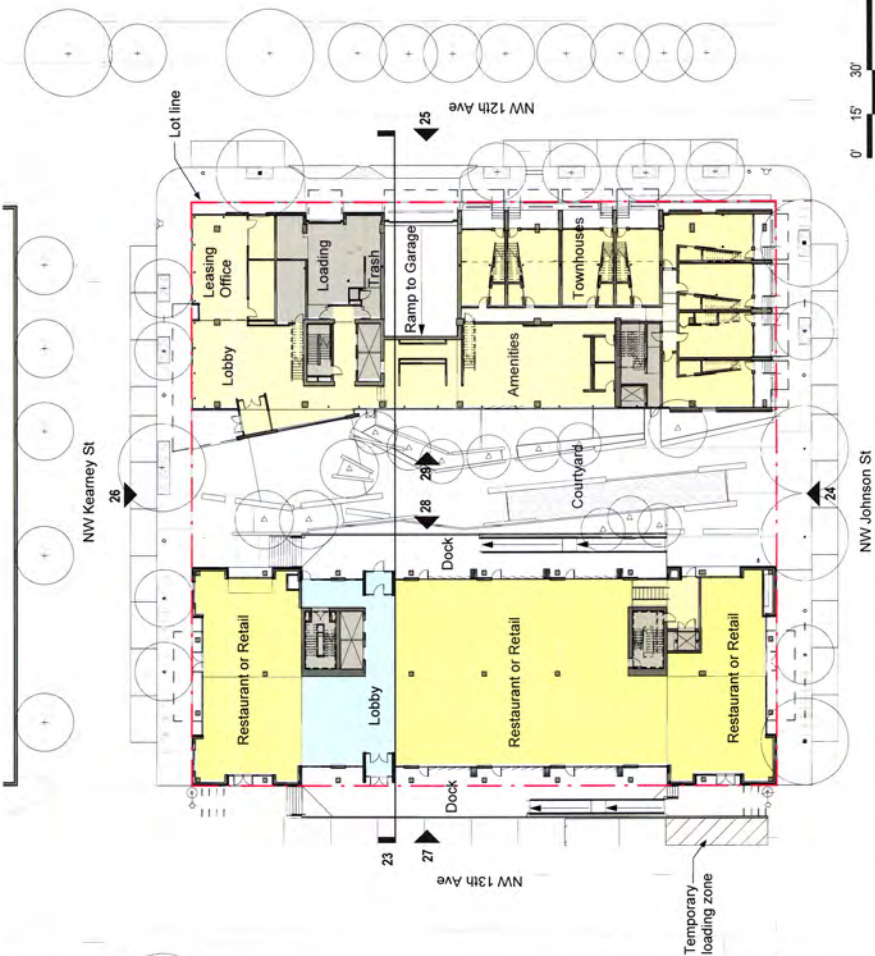

\*Approved\*  
 City of Portland  
 Bureau of Development Services  
 Planner *[Signature]*  
 Date *1/22/15*  
 \*This approval is subject to the reviews requested and is subject to a re-issuance of approval. Additional zoning requirements may apply.\*

EXH C-2

# Overall Project

## Typical Office & Residential Plans



# Overall Project

Building Section Looking North

## Height Request

Zone Maximum Height:	75'
General Bonus Height:	+45'
Subtotal:	120'
Residential Bonus Request: *	+ 30' (max 75')
Total Request:	150'

\* Reference Appendix for detail on height request

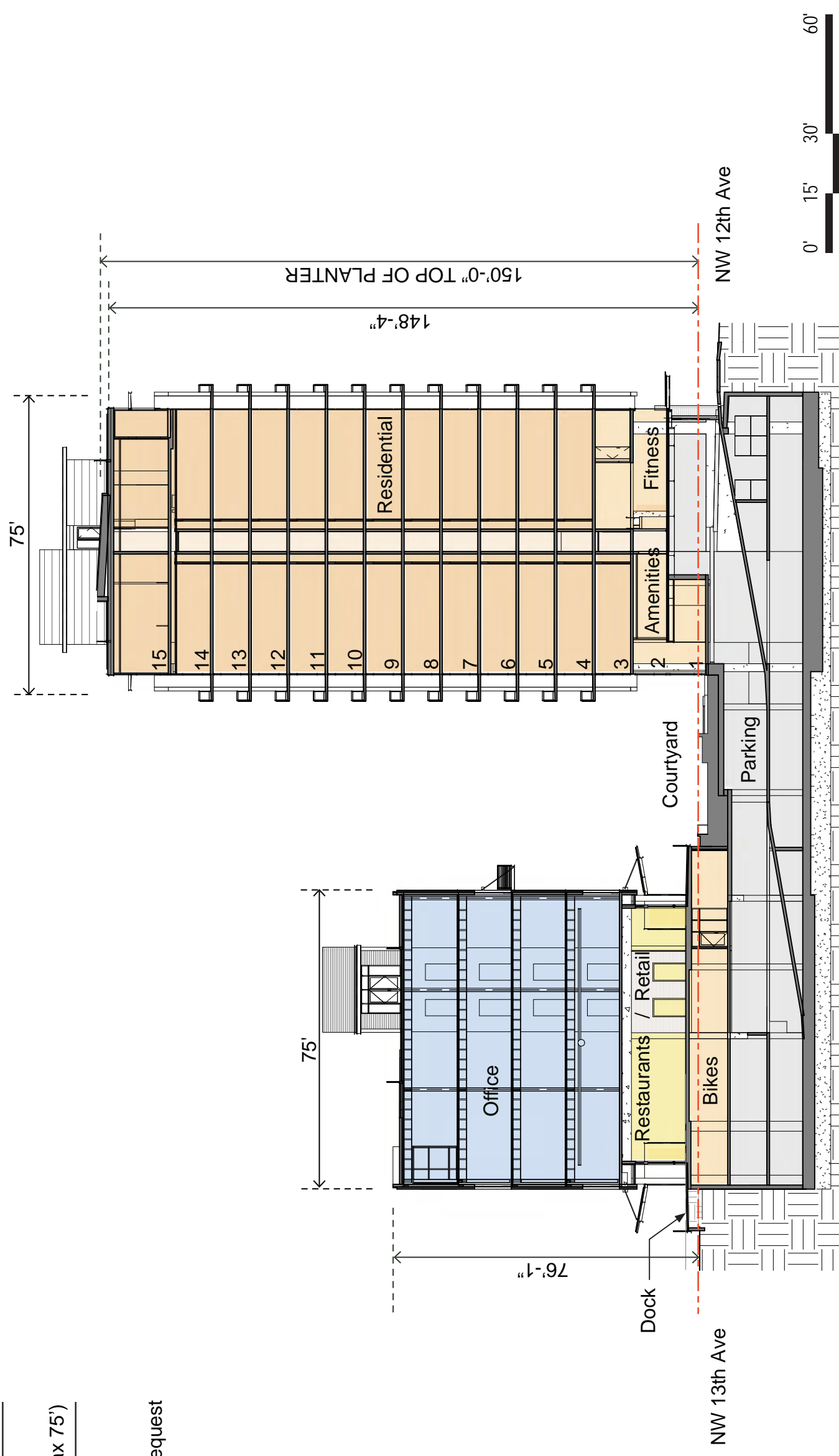

# Overall Project

South Project Elevation



\*Approved\*  
City of Portland  
Bureau of Development Services  
Planner: *[Signature]*  
Date: *1/22/15*  
\* This approval and its extent to all  
revisions requested and is subject to all  
conditions of approval.  
Additional zoning requirements may apply.



EXH C-3

# Overall Project

12th Avenue Building - East Elevation on 12th Avenue



\*Approved\*  
City of Portland  
Bureau of Development Services  
Planner: *[Signature]*  
Date: 1/22/15  
\* This approval is valid only to the  
amount of approval  
requested and is subject to all  
additional zoning requirements, may add.

0' 20' 40'

EXH C-4

# Overall Project

North Project Elevation

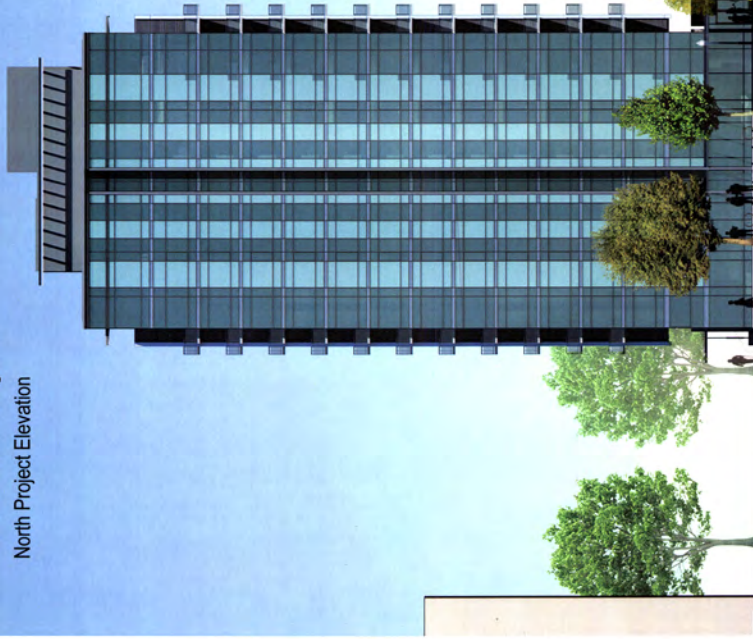

\*Approved\*  
City of Portland  
Bureau of Development Services  
Planner *[Signature]*  
Date *[Signature]*  
\* This approval applies only to the  
reviews requested and is subject to all  
conditions of approval.  
Additional zoning requirements may apply.

0' 20' 40'

EXH-C-5

# Overall Project

13th Avenue Building - West Elevation on 13th Avenue



Approved  
City of Portland  
Bureau of Development Services  
Planner  
Date  
This document is subject to all  
revised conditions of approval.  
Additional zoning requirements may apply.

0' 20' 40'

EXHC-6



# Overall Project

13th Avenue Building - East Elevation at Courtyard



# Overall Project

12th Avenue Building - West Elevation at Courtyard



# Overall Project

## Materials Palette

### 12th Ave



Board-Formed Concrete

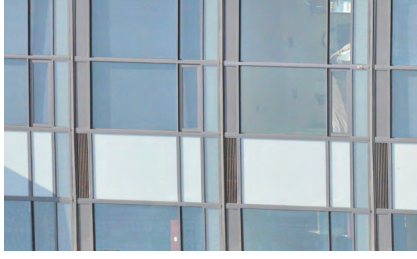

Window-wall



Glass & Prefinished Alum Railing

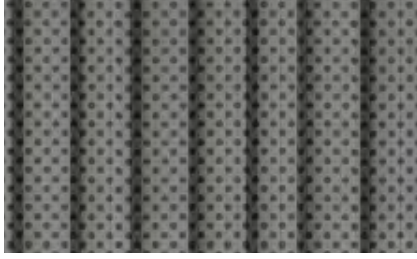

Perforated Corrugated Metal



Painted Accent Color

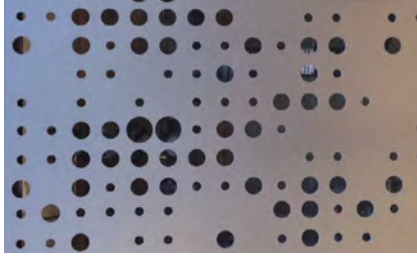

Perforated Metal Screens

### Shared

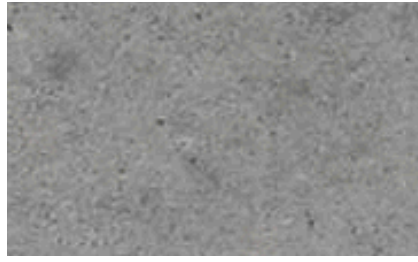

Concrete



Corrugated Metal

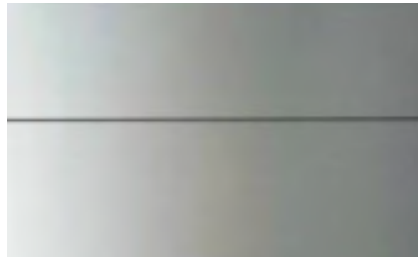

Alum Composite Panel

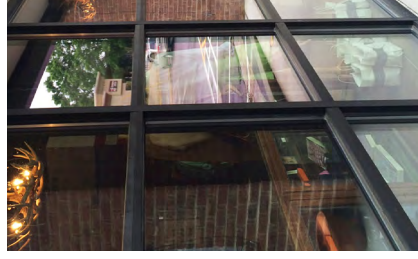

Storefront



Prefin. Metal Parapet Cap

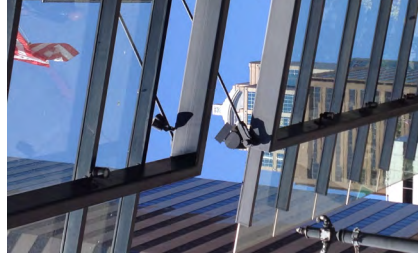

Painted Structure

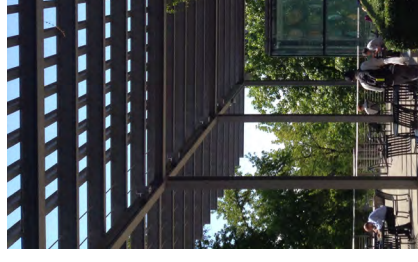

Painted Steel Trellis

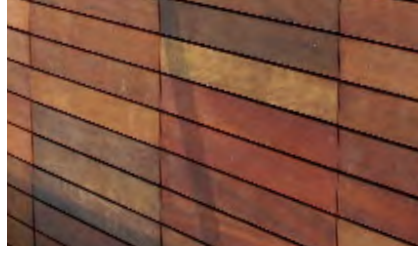

Ipe Decking



Green Roof

### 13th Ave

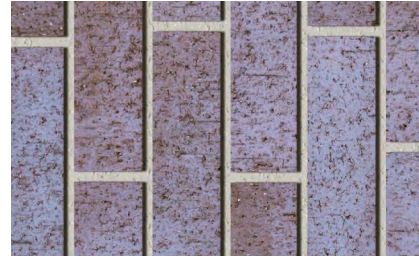

Brick



European Vinyl Windows



Painted Rails w/ SS cables



Wood Soffits



Colorful French Doors

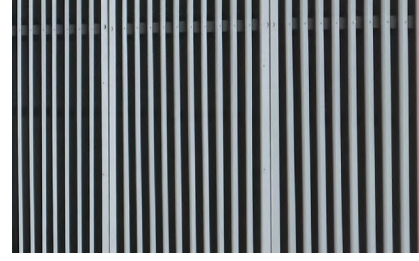

Metal Louver

# Streetscape

Project View from Southwest



# Streetscape

## Materials Plan

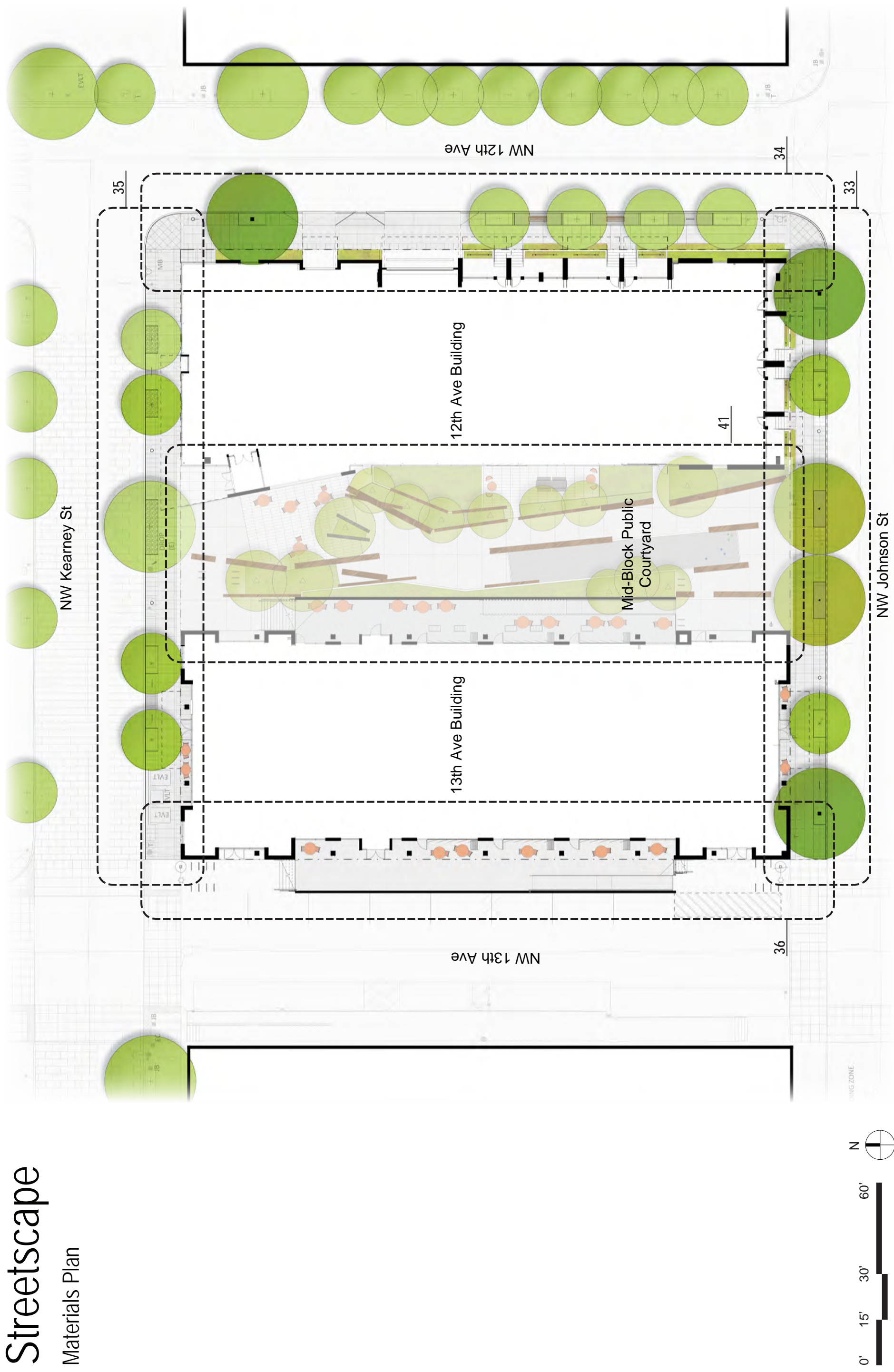

# Streetscape

## NW Johnson Street Plan and Elevation

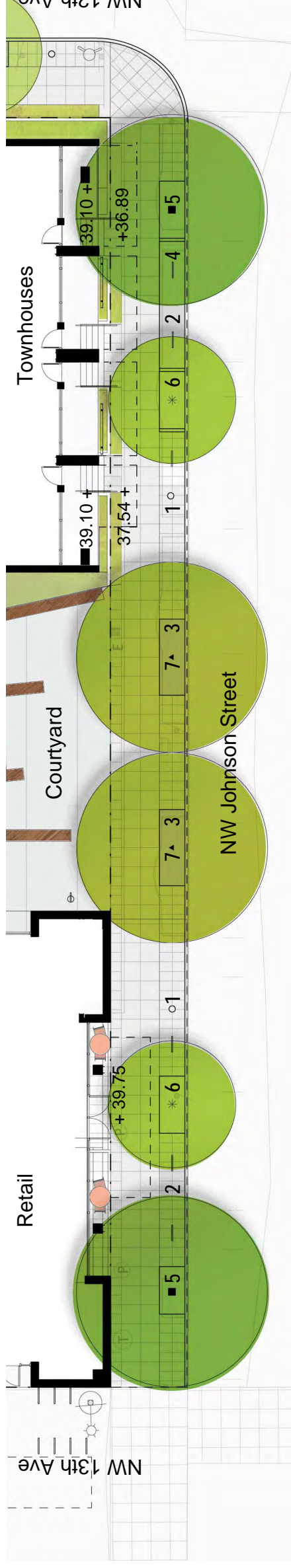

A NW Johnson Street Plan

- 1 Single Fixture Historic Streetlight
- 2 Bicycle Rack in Furnishing Zone (6) Horseshoe Rack, Surface Mount, Stainless steel finish



- 3 Tree Grate  
Urban Accessories, Jamison Grate  
Recycled Grey Iron



- 4 Permeable Concrete Unit Pavers  
Mutual Materials, Eco-Priora, 4" x 8"

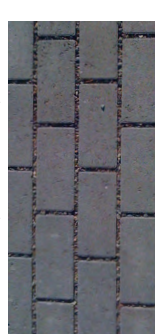

Trees

- 5 Palmore Ash,  
Fraxinus pennsylvanica 'Palmore'
- 6 American Hophornbeam,  
Ostrya virginiana
- 7 Black Tupelo,  
Nyssa sylvatica



B NW Johnson Street Elevation

# Streetscape

## NW 12th Avenue Plan and Elevation

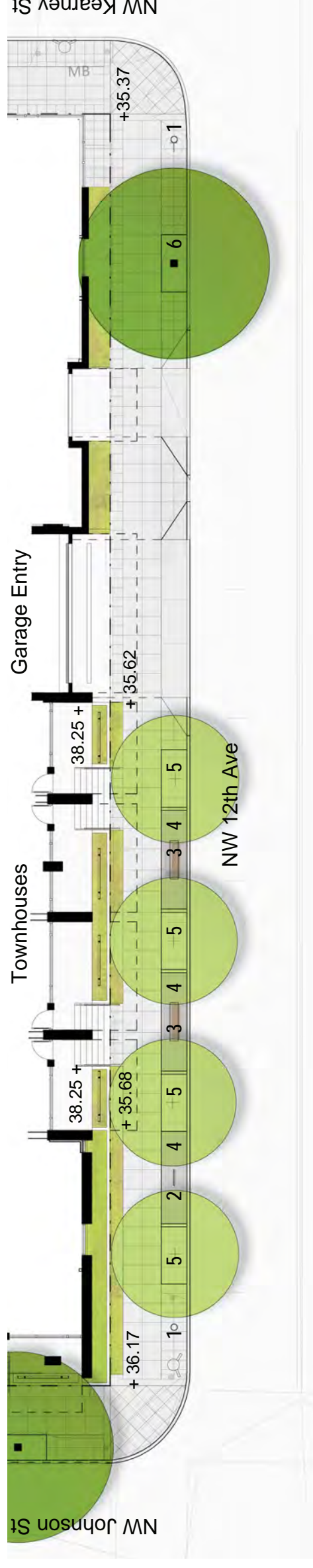

**A** NW 12th Avenue Plan

- 1 Twin Fixture Historic Streetlight
- 2 Bicycle Rack in Furnishing Zone (1)  
Horseshoe Rack, Surface Mount, Stainless steel finish



- 3 Benches in Furnishing Zone (2)  
Forms + Surfaces, Knight Bench, Reclaimed Teak with aluminum frame, 6' L



- 4 Permeable Concrete Unit Pavers  
Mutual Materials, Eco-Priora, 4" x 8"

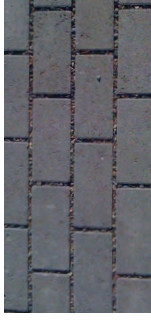

### Trees

- 5 Existing Maple, 7-8" Caliper
- 6 Patmore Ash, *Fraxinus pennsylvanica* 'Patmore'



**B** NW 12th Avenue Elevation

# Streetscape

## NW Kearney Street Plan and Elevation

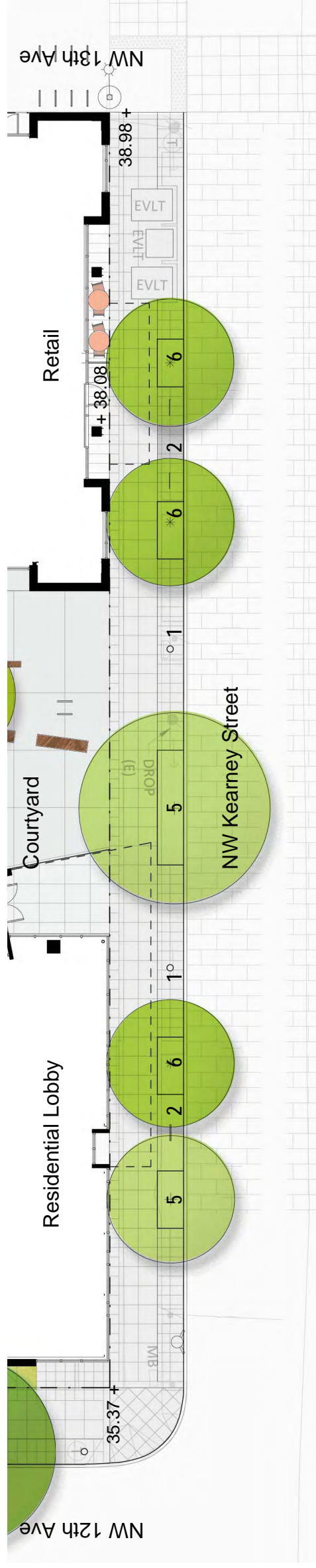

- 1 Single Fixture Historic Streetlight
- 2 Bicycle Rack in Furnishing Zone (3)  
Horseshoe Rack, Surface Mount, Stainless steel finish



### A NW Kearney Street Plan

#### Trees

- 5 Existing Linden, 14" Caliper
- 6 American Hophornbeam,  
*Ostrya virginiana*



### B NW Kearney Street Elevation



# Streetscape

## NW 13th Avenue Plan and Elevation

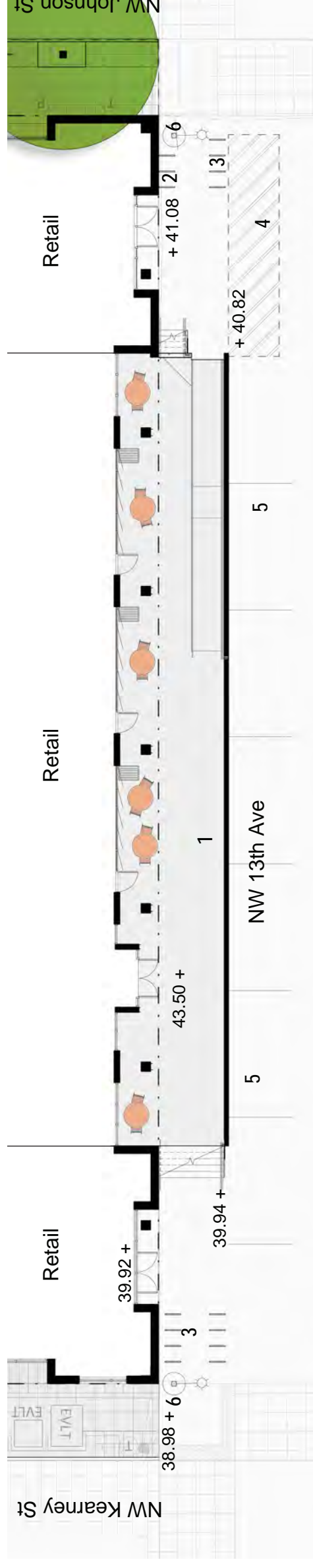

A NW 13th Avenue Plan

- 1 Elevated Dock
- 2 Bicycle Rack - Wall Mount

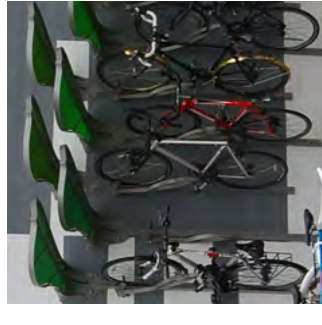

- 3 Bicycle Rack - Surface Mount (12)  
Horseshoe Rack, Surface Mount, Stainless steel finish



- 4 Proposed Loading Space  
Loading space in R.O.W. has been requested of PBOT but is not counted as one of the project's required loading spaces.

- 5 Parallel Parking (5)
- 6 Existing Cobra Head Light

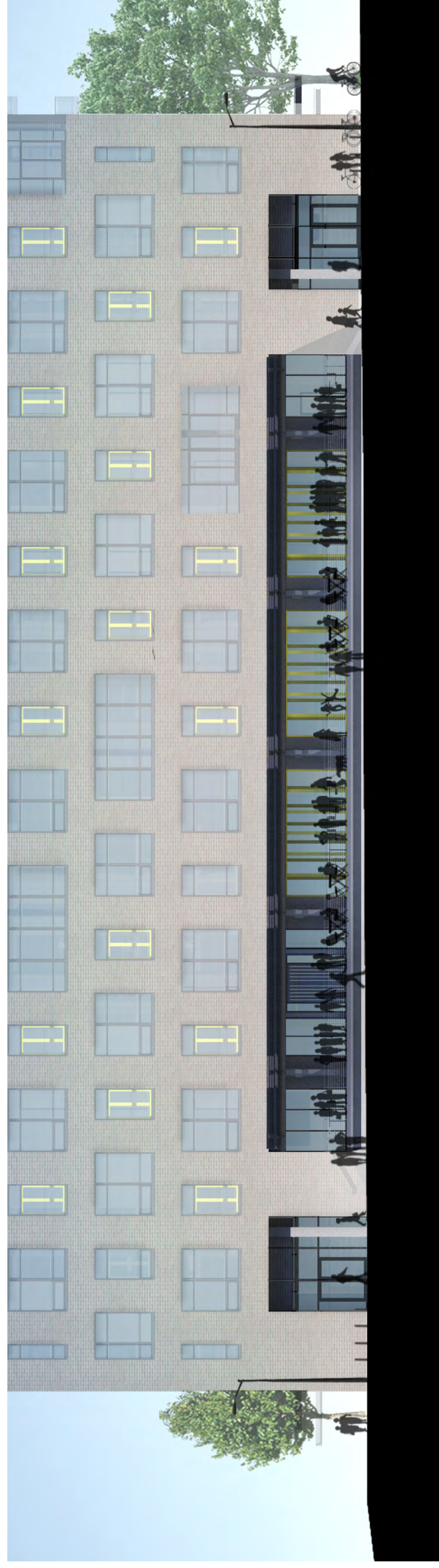

B NW 13th Avenue Elevation

# Streetscape

## Streetscape Plant Schedule

### Plants

BOTANICAL NAME	COMMON NAME	SIZE	ROOT CONDITION	ON-CENTER SPACING
<b>TREE</b>				
Fraxinus pennsylvanica 'Patmore'	PATMORE ASH	4" CAL.	CONTAINER	AS SHOWN
Nyssa sylvatica	BLACK TUPELO	4" CAL	CONTAINER	AS SHOWN
Ostrya virginiana	AMERICAN HOPHORNBEAM	4" CAL	CONTAINER	AS SHOWN
<b>SHRUB</b>				
Cephalotaxus harringtonia 'Fastigiata'	UPRIGHT JAPANESE PLUM YEW	5 GAL	CONTAINER	24" O.C.
Hydrangea quercifolia	OAKLEAF HYDRANGEA	5 GAL	CONTAINER	24" O.C.
Sarcococca confusa	SWEETBOX	3 GAL	CONTAINER	24" O.C.
<b>GROUNDCOVER</b>				
Hakonechloa macra	JAPANESE FOREST GRASS	1 GAL	CONTAINER	12" O.C.
Juncus effusus var. Pacificus	SOFT RUSH	1 GAL	CONTAINER	12" O.C.
<b>VINE</b>				
Trachelospermum asiaticum	STAR JASMINE	3 GAL.	CONTAINER	36" O.C.

### Street Trees



**Black Tupelo**  
Nyssa sylvatica

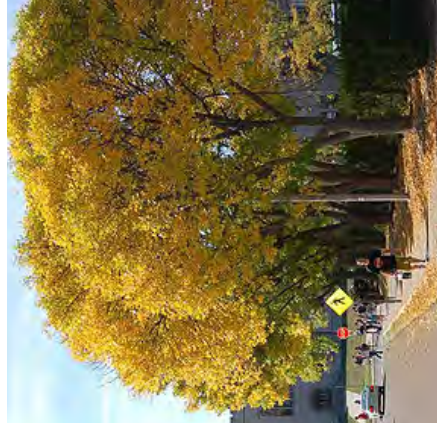

**Patmore Ash**  
Fraxinus pennsylvanica 'Patmore'



**American Hophornbeam**  
Ostrya virginiana



### Shrubs and Vines



**Sarcococca**  
Sarcococca confusa



**Oakleaf Hydrangea**  
Hydrangea quercifolia



**Japanese Forest Grass**  
Hakonechloa macra



**Japanese Plum Yew**  
Cephalotaxus harringtonia 'fastigiata'



**Star Jasmine**  
Trachelospermum asiaticum

# Courtyard

## Pearl District Courtyard Study

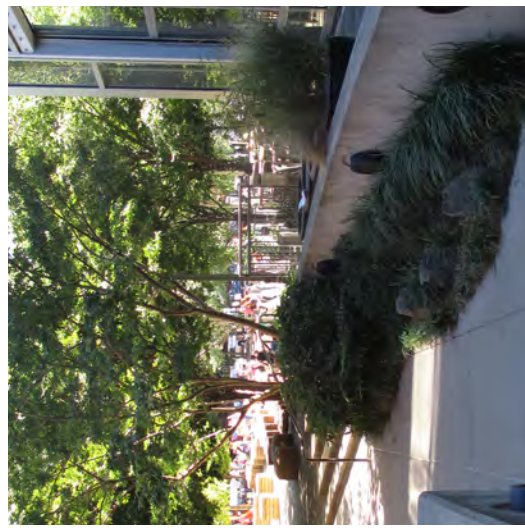
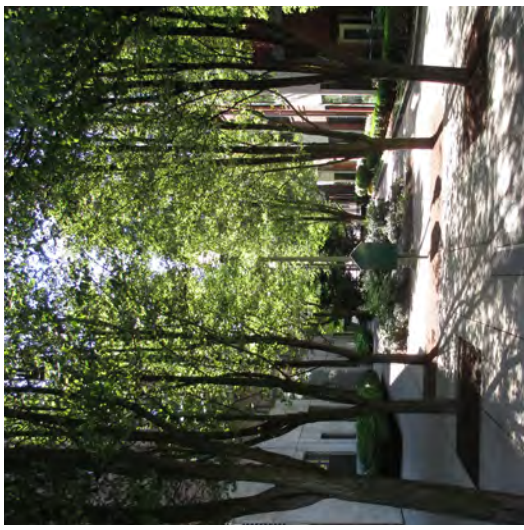
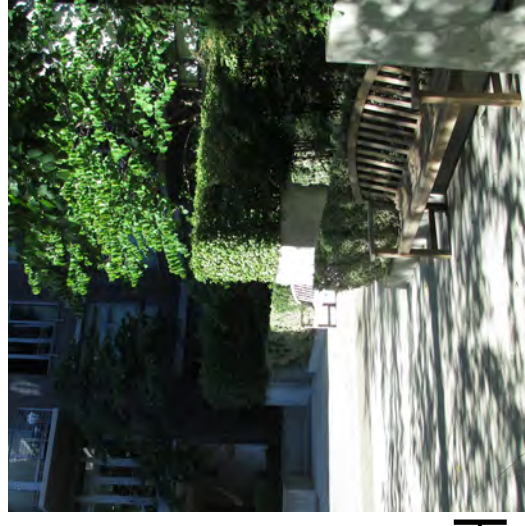
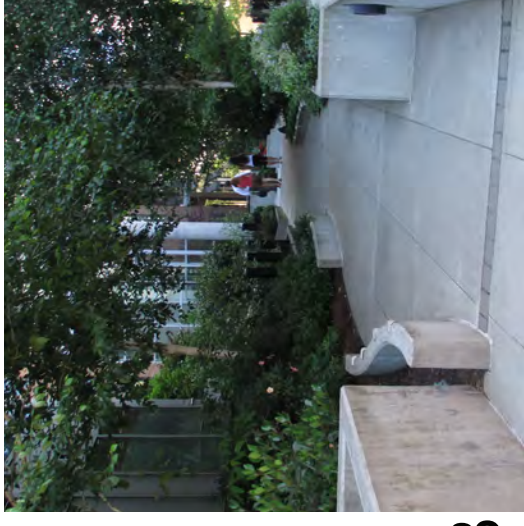
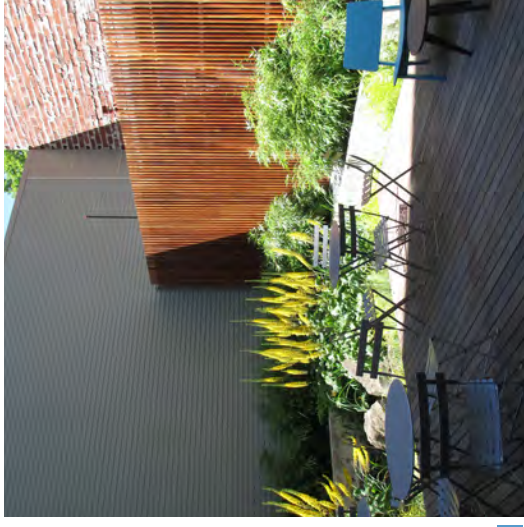



# Courtyard

Concept



# Courtyard

Plan

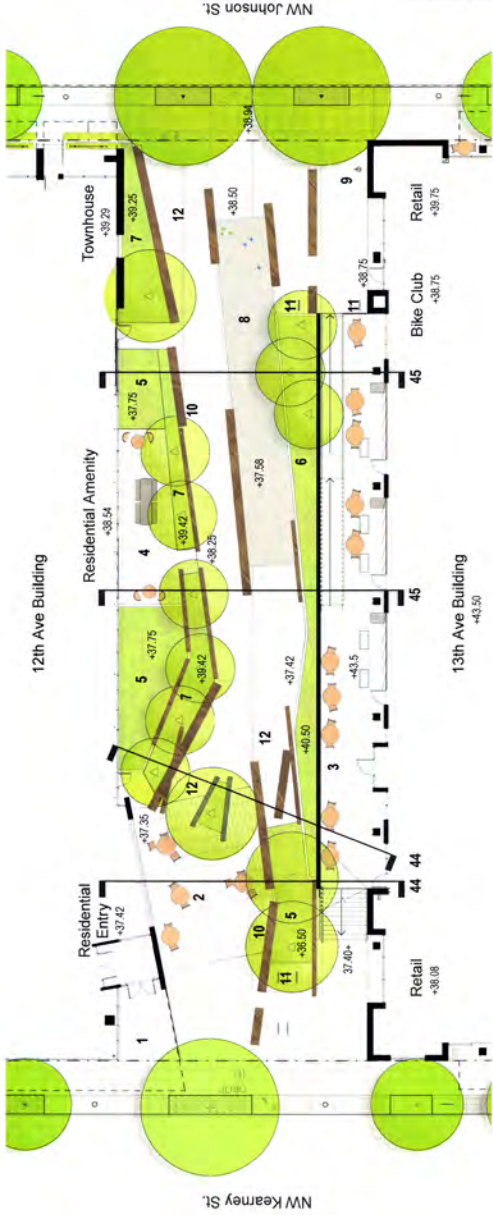

Approved  
 City of Portland  
 Bureau of Development Services  
 Date: 1/24/15  
 This plan is subject to all  
 applicable codes and regulations.  
 The applicant is responsible for  
 obtaining all necessary permits.

- 1 Entry Plaza**  
Sidewalk joint pattern continues to residential entry, scored concrete surface flush with adjacent sidewalk
- 2 Sealing Area with Concrete Pavers**  
Mortar set concrete pavers designate zone for movable furniture, event focused space
- 3 Dock Seating Area**  
Overflow from interior program, elevated 2' above courtyard. Accessible from stair at north end, ramp at south end
- 4 Spillout Amenity Space**  
Mortar set paver zone spills out from interior common space.
- 5 Bioretention Planter, Recessed**  
Captures water from adjacent pedestrian surfaces, 6" below adjacent grade. Standard soil and gravel section with 6" ponding.
- 6 Bioretention Planter, Elevated**  
Captures water from adjacent building's roof terrace. Standard soil and gravel section with 6" ponding.
- 7 Elevated Planter**  
Depth varies 16-30".
- 8 Boocoo Court with Aggregate Surfacing**  
Crushed oyster shell playing surface over sand and crushed rock layers with underdrainage. Serves as sand filter for pedestrian zones around court.
- 9 Public Bicycle Workstation**  
Free standing station with hanger arms to support bike. Includes most commonly used tools for simple bike repair and pump, securely attached to station with cables.
- 10 Log Jam Benches**  
Reclaimed lumber features, range from flush to high. Primarily serve as benches. Details on page 45.
- 11 Bike Parking Zones**
- 12 Log Jam Flow**  
Reclaimed lumber features direct pedestrian movement, through flows and eddies.



# Courtyard

## Enlarged Plan

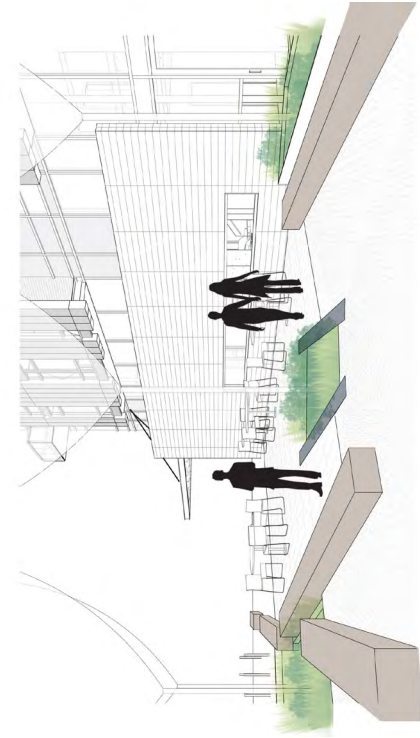
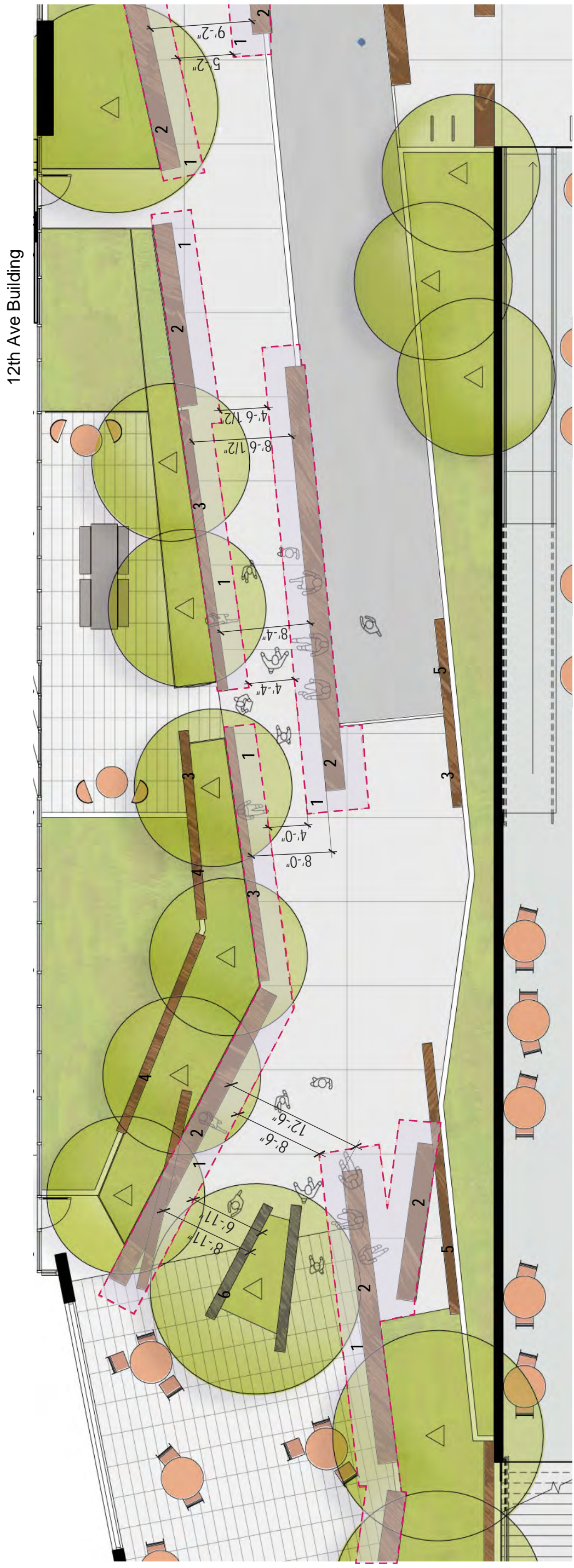

- 1 Bench Access Zone**  
Allowance of 2'-0" from bench face for access to bench and clear space from pedestrian walkway
- 2 Reclaimed Timber Bench - Typical**  
Typical Bench consisting of two reclaimed columns for a seat depth of 22-1/2"
- 3 Reclaimed Timber Bench - Narrow**  
Bench consisting of one reclaimed timber column for a seat depth of 11"
- 4 Reclaimed Timber Wall Cap**  
See detail B / page 46
- 5 Timber Wall Hanging**  
See detail D / page 46
- 6 Flush Paving Accent**  
See detail C / page 46







# Courtyard

View from North



PORTLAND BLOCK 136

LAND USE APPLICATION LU14-230014 DZM AD

January 22, 2015

# Courtyard

View looking North



# Courtyard

Overlapping Program

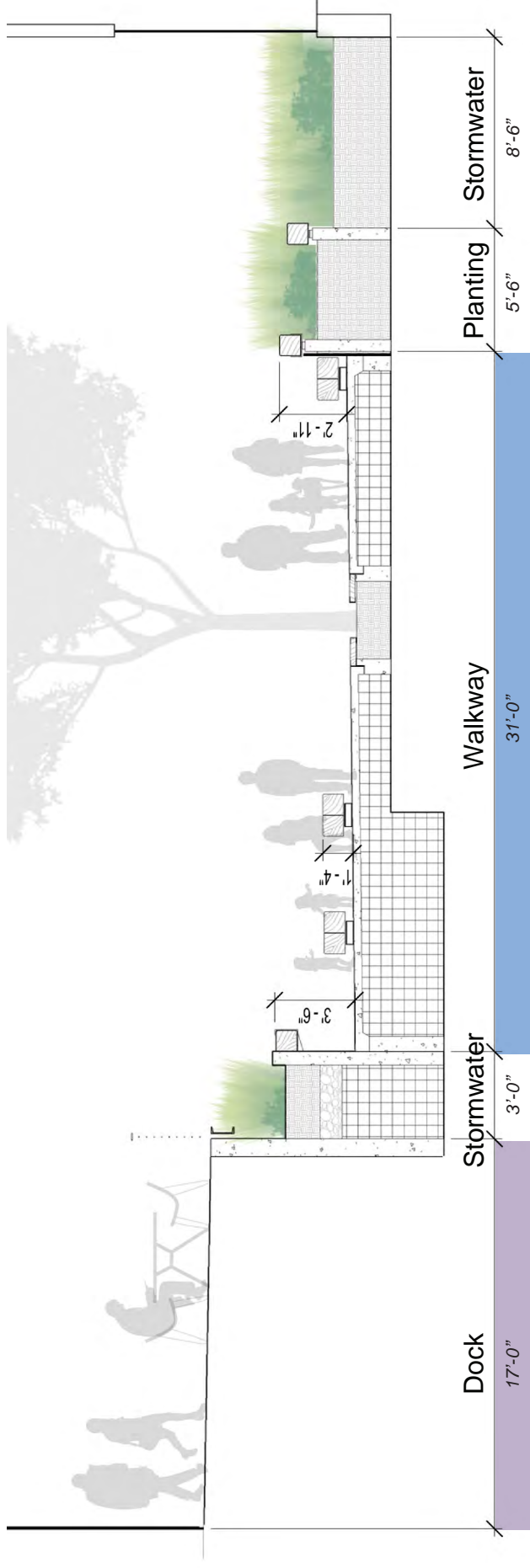

A Section through Seating Area looking North

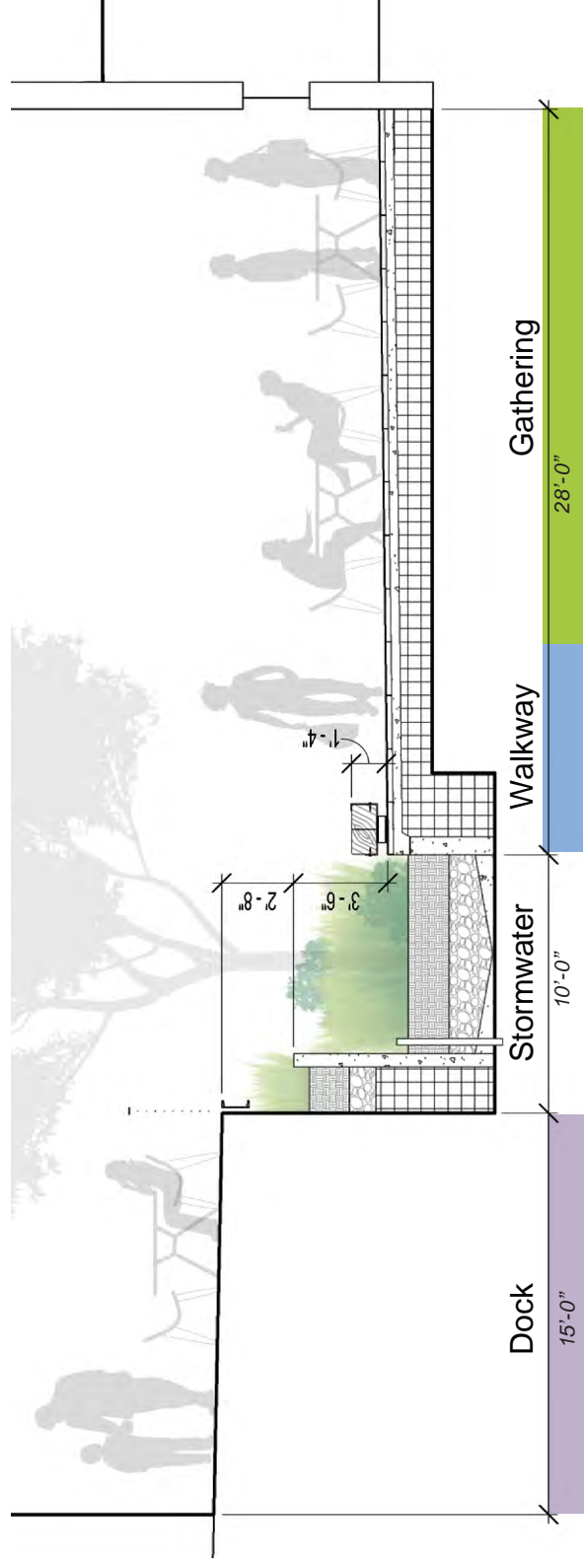

B Section through Seating Area looking North

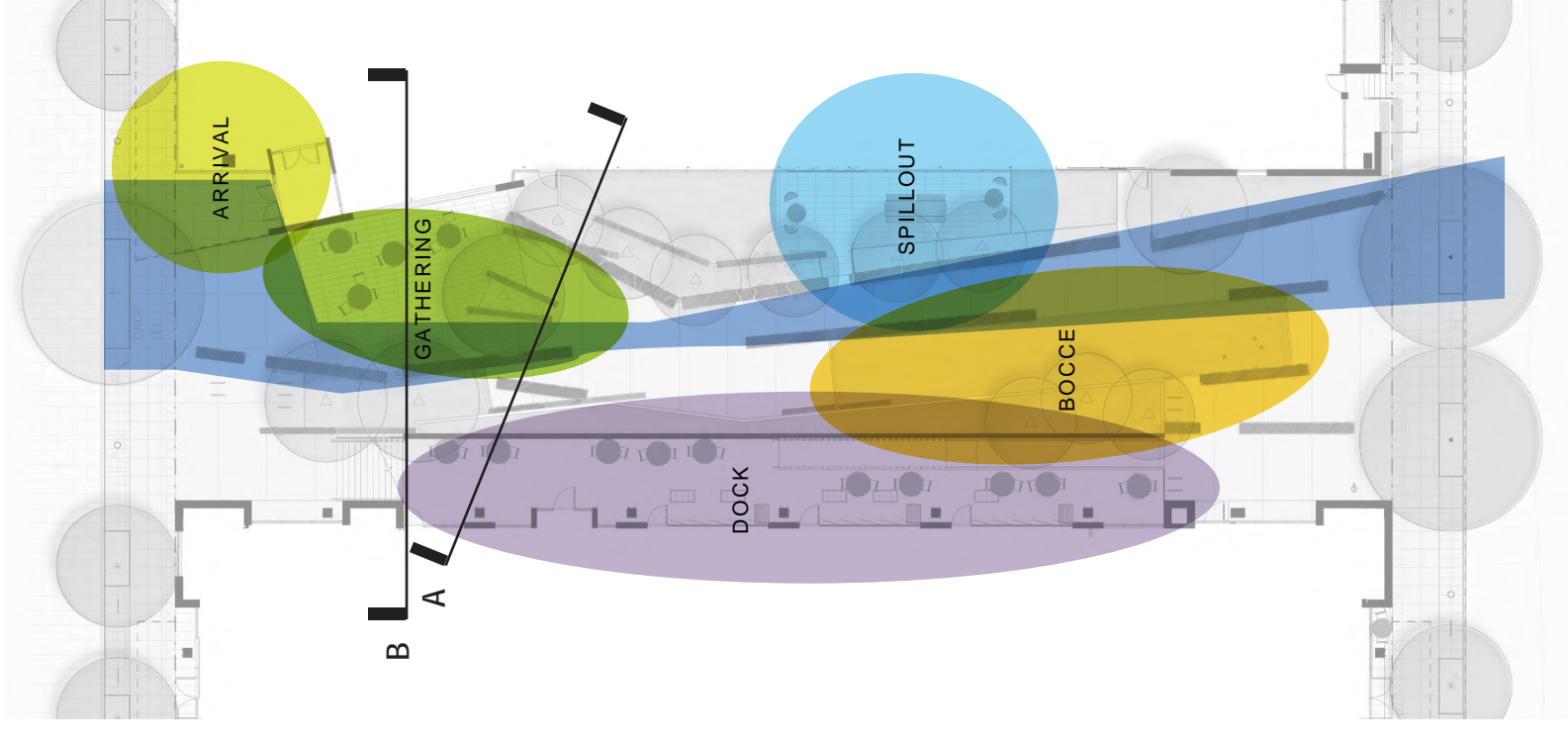

# Courtyard

## Overlapping Program

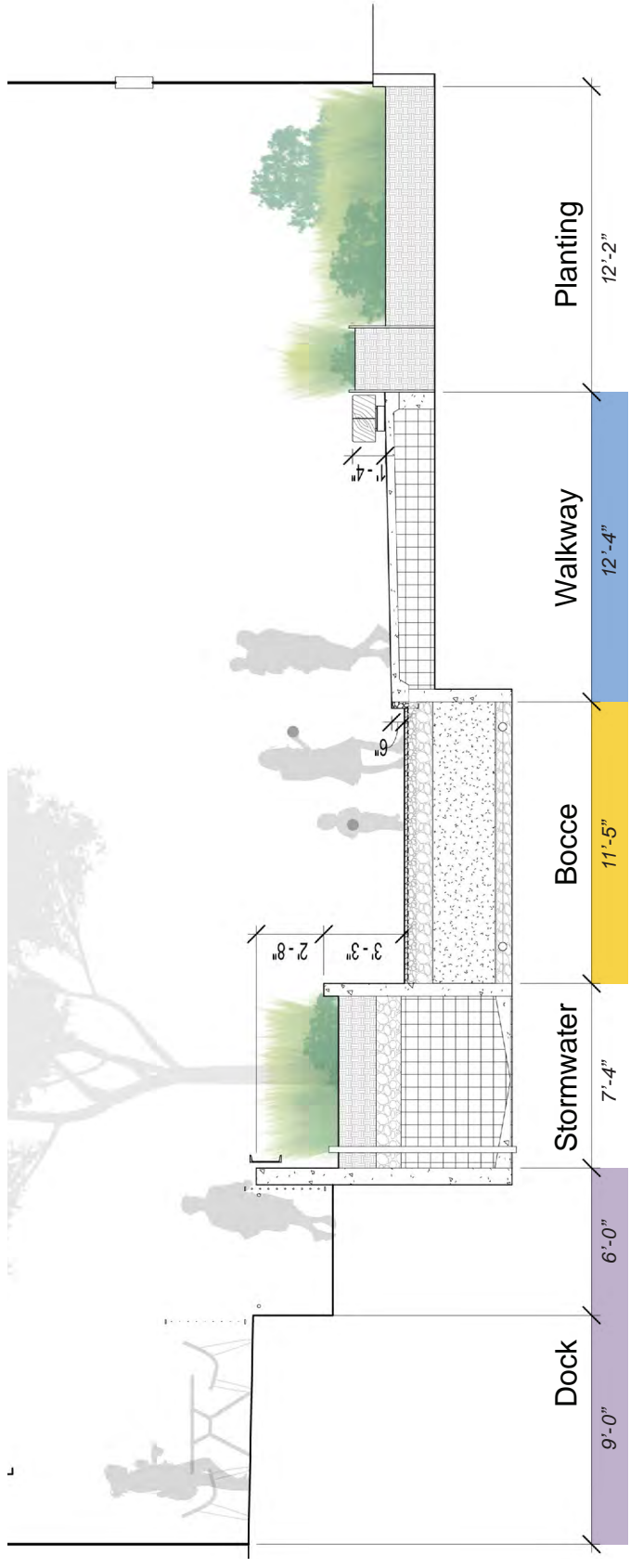

A Section through Bocce Court looking North

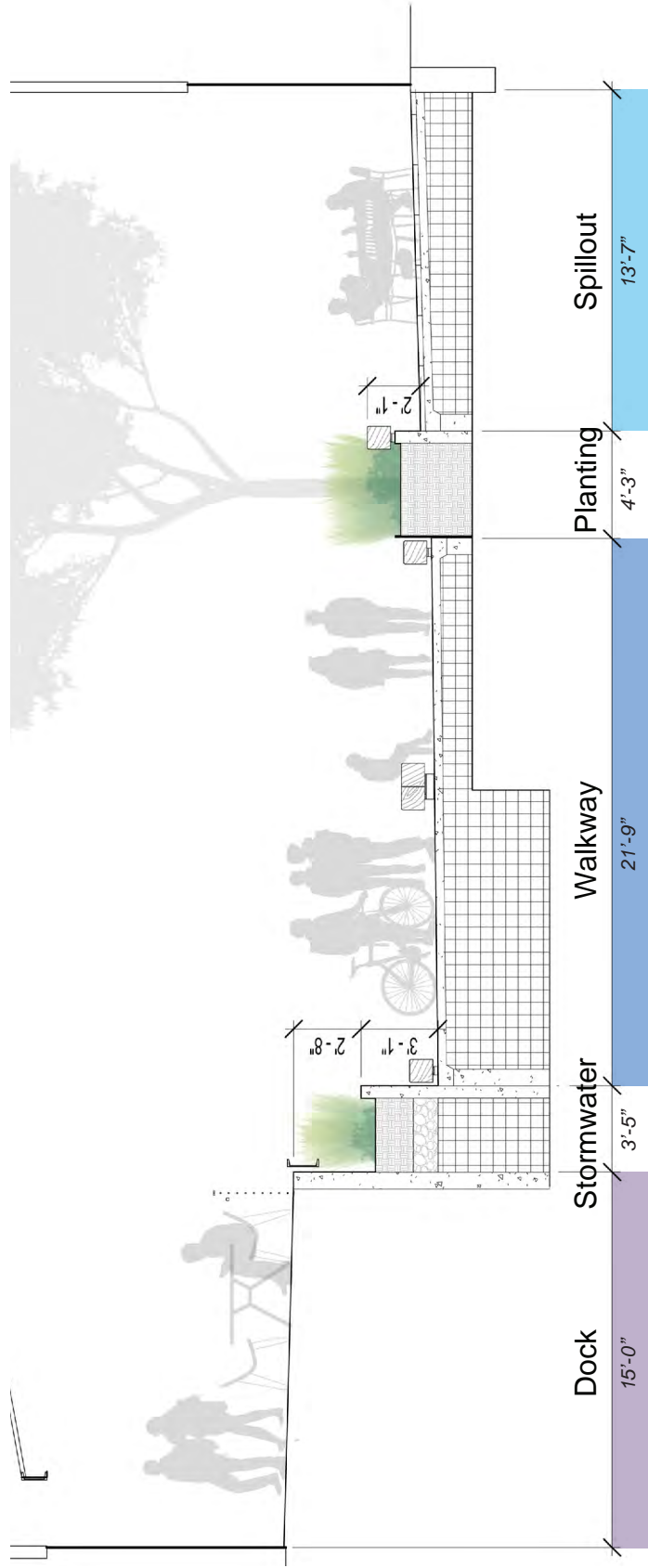

B Section through Amenity Spillover Space looking North

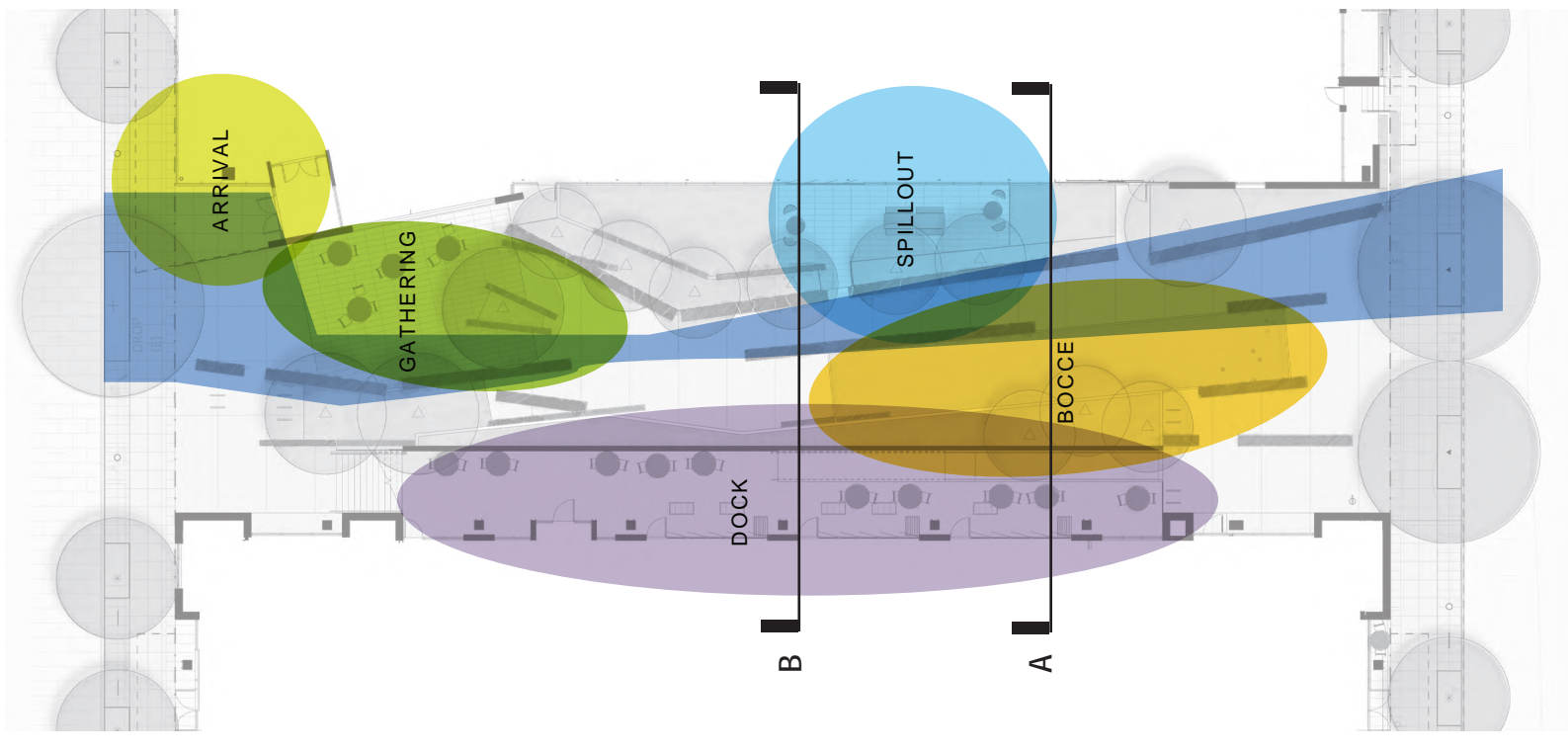

# Courtyard

## Details

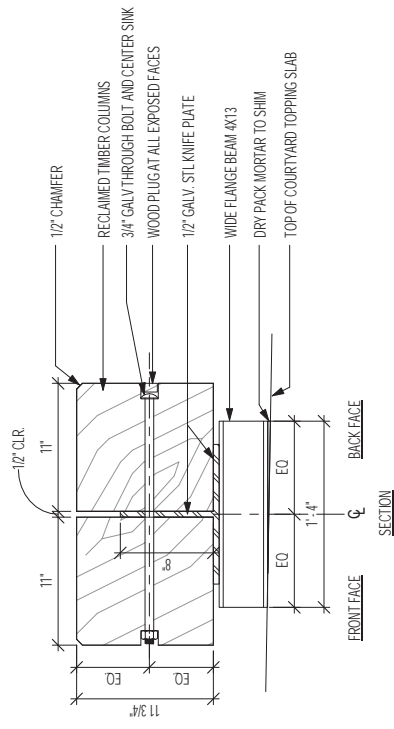

**A Reclaimed Timber Bench Frame Detail**

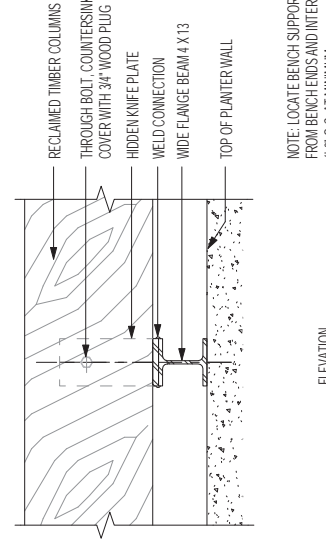
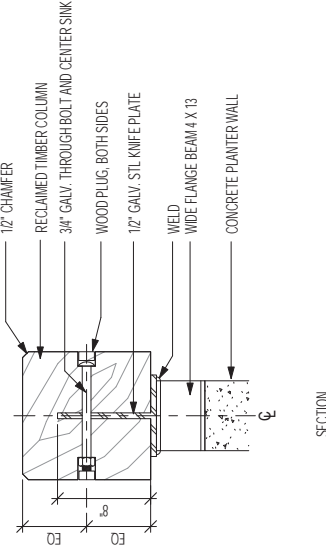
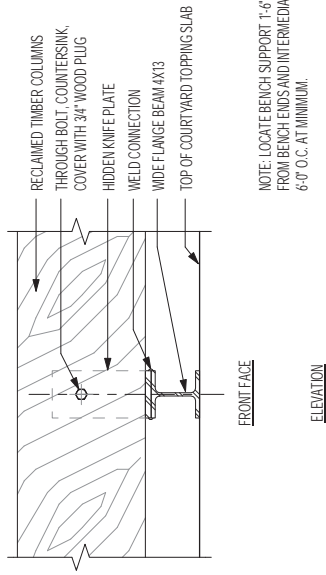

NOTE: LOCATE BENCH SUPPORT 1'-6" FROM BENCH ENDS AND INTERMEDIATES 6'-0" O.C. AT MINIMUM.

**B Reclaimed Timber Wall Cap Detail**

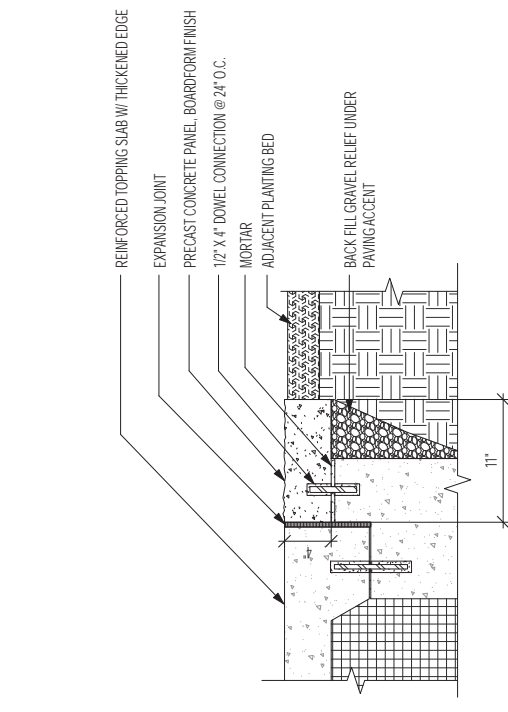

**C Flush Paving Accent Detail**

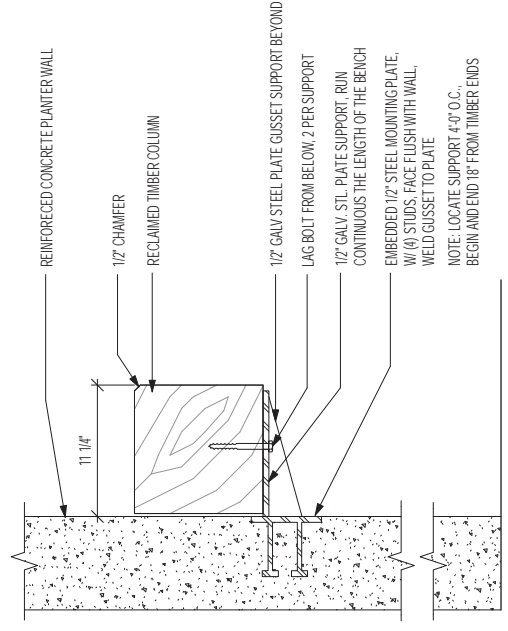

**D Timber Wall Hanging**

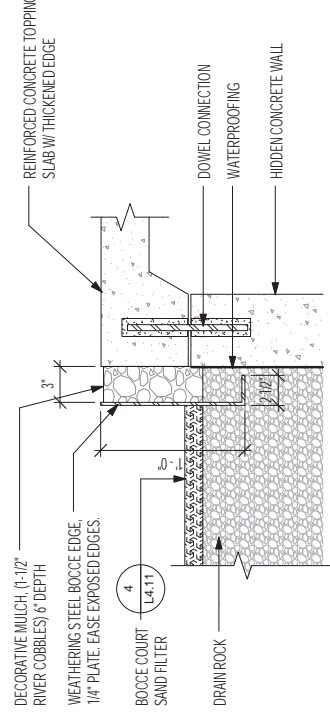

**E Exposed Drain at Bocce Court**

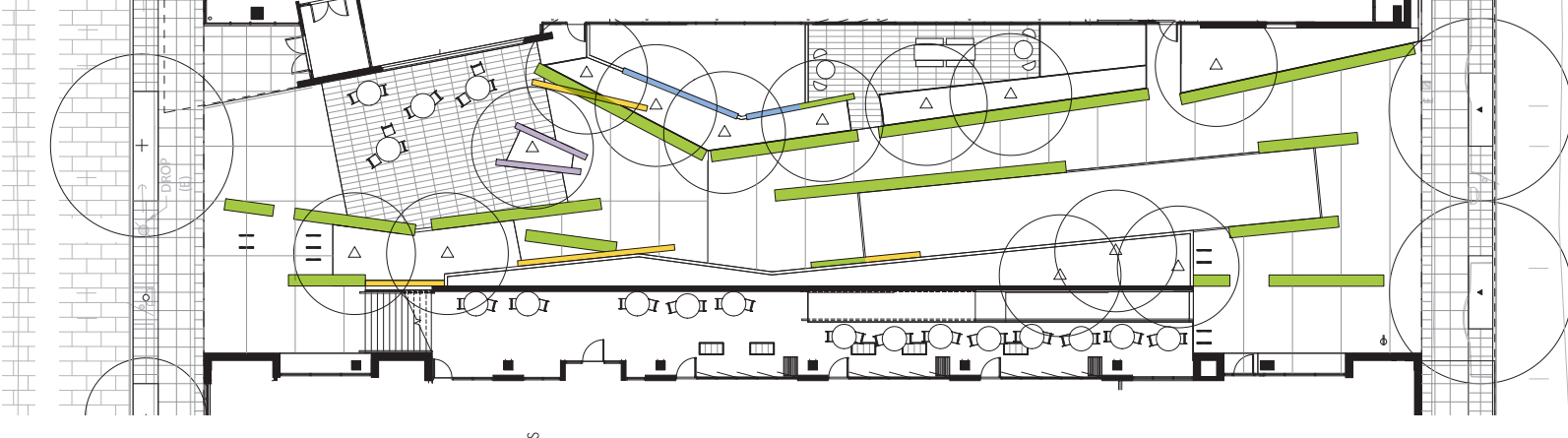

# Courtyard

## Material Precedents



Reclaimed Timber Site Furnishings



Concrete Planter Walls



Painted Steel Planter Walls

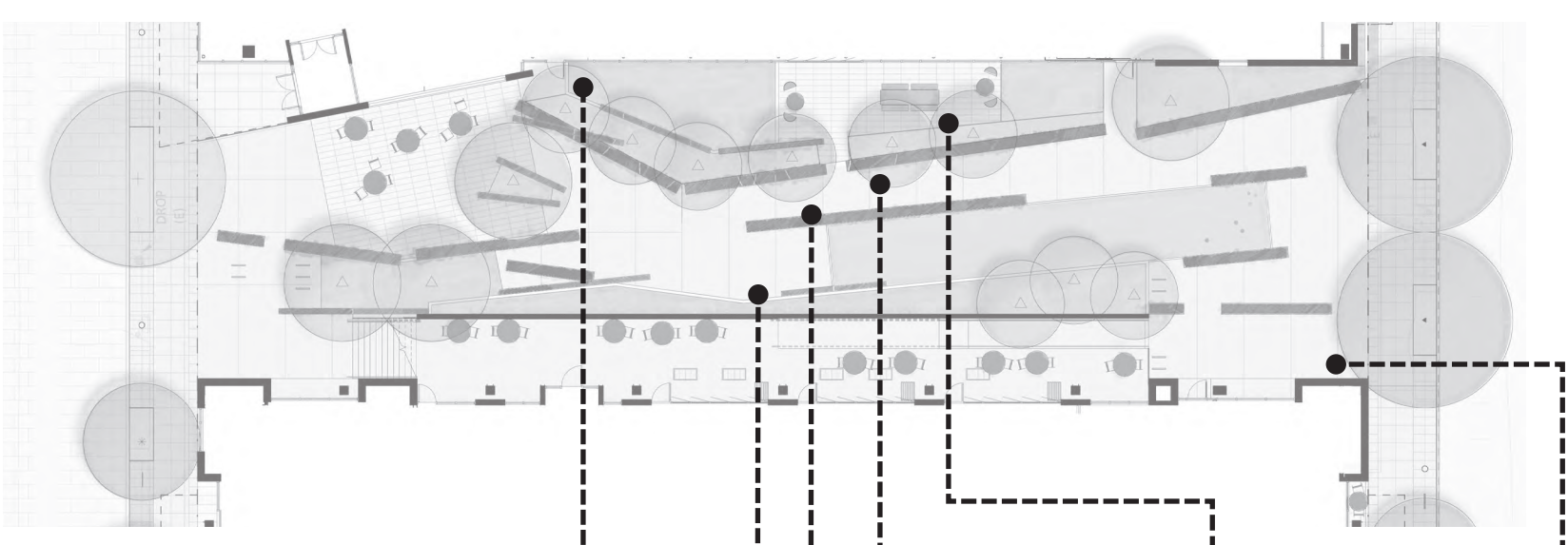

Movable Tables and Chairs



Public Bike Workstation

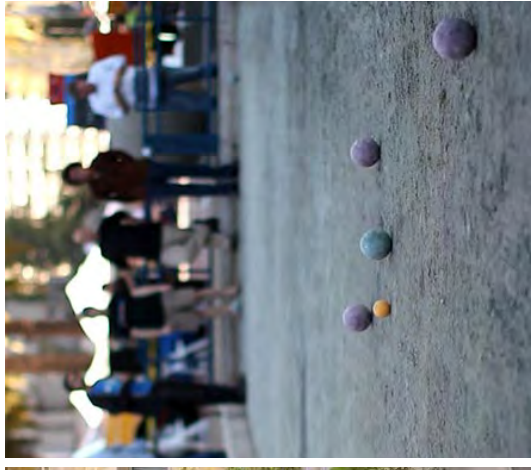

Bocce Court



Sawcut Concrete Score Pattern



Narrow Modular Concrete Pavers

# Courtyard

Planting Design Concept

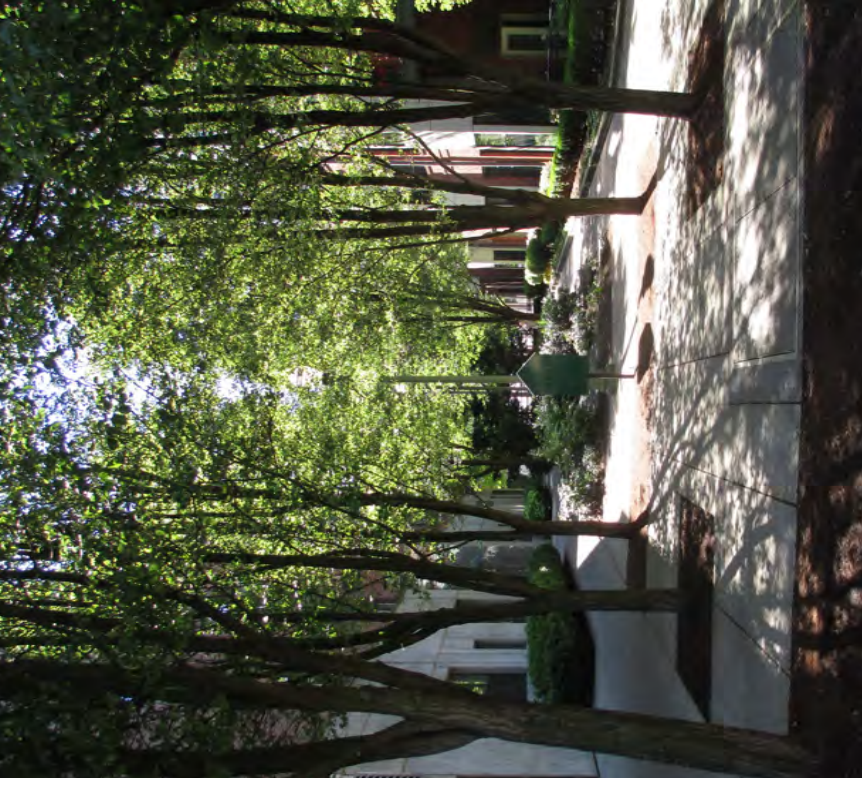

Precedent

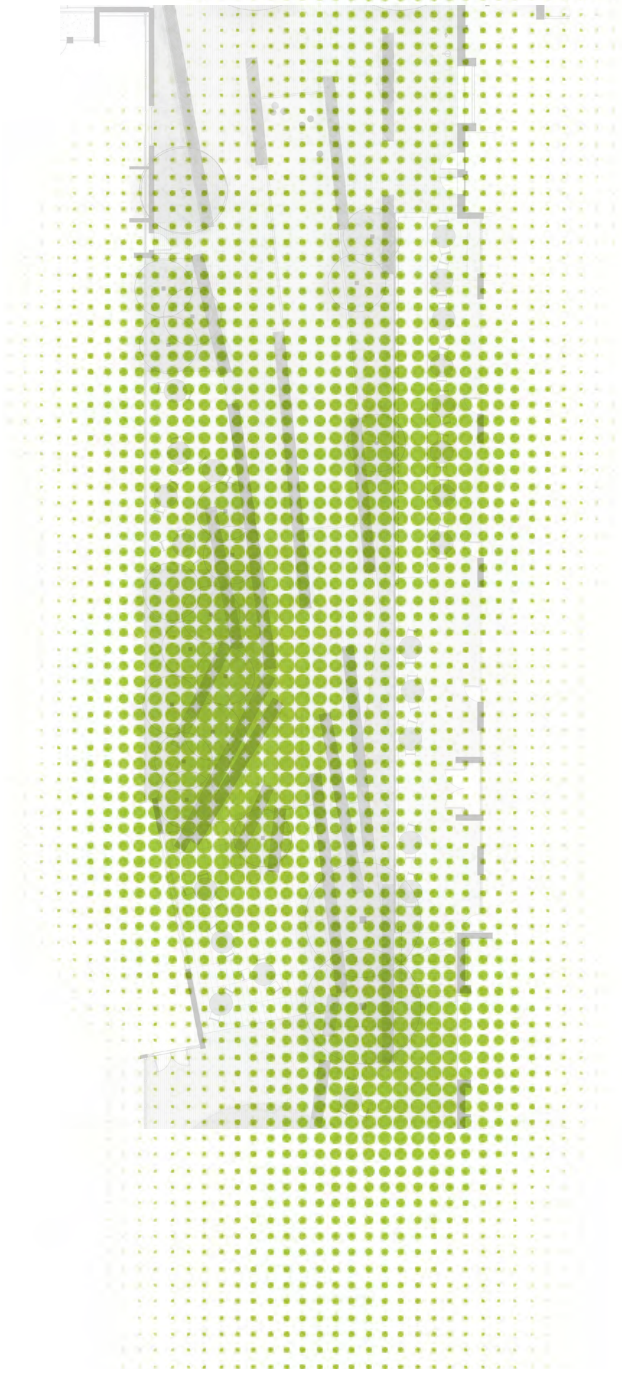

Accretion



Canopy

# Courtyard

## Planting Plan

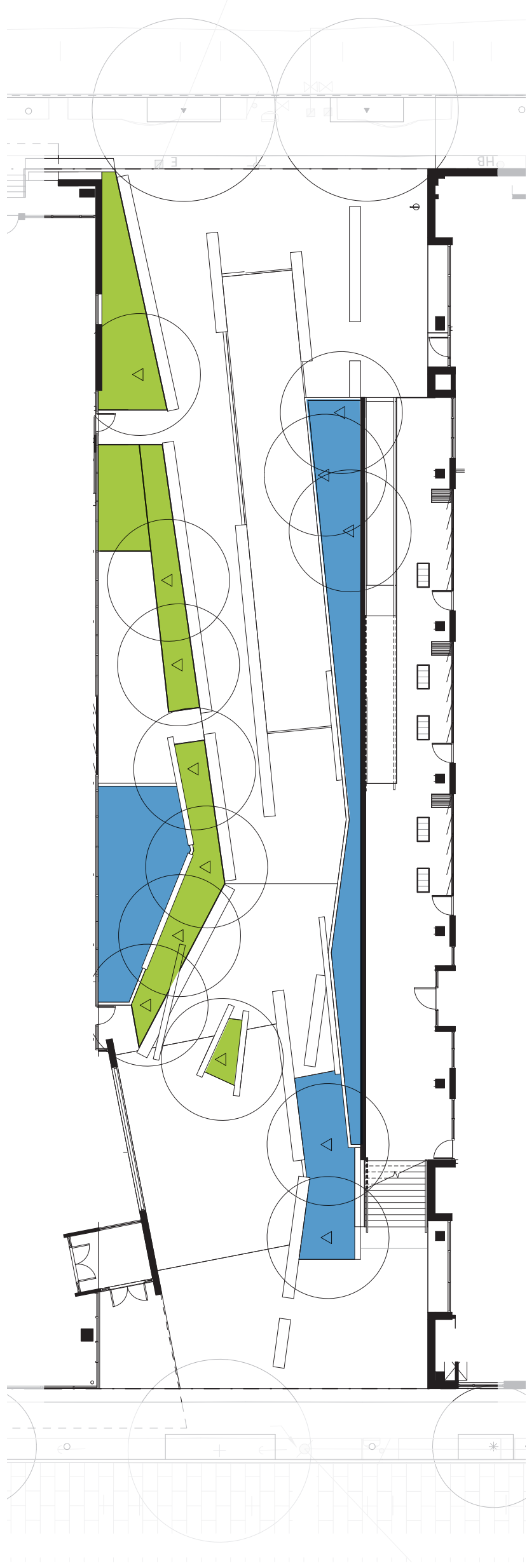

## Courtyard Planting Plan

BOTANICAL NAME	COMMON NAME	SIZE	ROOT CONDITION	ON-CENTER SPACING
<b>. TREE</b>				
GLEDITSIA TRIACANTHOS	THORNLESS HONEY LOCUST	3" CAL	CONTAINER	AS SHOWN
<b>BRPA</b>				
CAREX DEWEYANA	DEWEY SEDGE	1 GAL	CONTAINER	18" O.C.
JUNCUS EFFUSUS VAR. PACIFICUS	SOFT RUSH	1 GAL	CONTAINER	12" O.C.
DESCHAMPSIA CESPITOSA	TUFTED HAIR GRASS	1 GAL	CONTAINER	12" O.C.
ELEOCHARIS ACICULARIS	NEEDLE SPIKE RUSH	1 GAL	CONTAINER	12" O.C.
<b>PERENNIALS</b>				
ACTAEA SIMPLEX 'BRUNETTE'	BLACK-LEAFED SNAKEROOT	1 GAL	CONTAINER	18" O.C.
<b>SHRUB</b>				
SYMPHORICARPOS ALBUS	SNOWBERRY	3 GAL	CONTAINER	36" O.C.
ARUNCUS DIOICUS	GOAT'S BEARD	1 GAL	CONTAINER	36" O.C.
DRYOPTERIS ERYTHROSORA 'BRILLIANCE'	AUTUMN FERN	1 GAL	CONTAINER	18" O.C.
TRILLIUM OVATUM	TRILLIUM	1 GAL	CONTAINER	12" O.C.

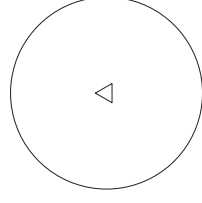



# Courtyard

## Planting Palette

### Canopy



Thornless Honey Locust *Gleditsia triacanthos*

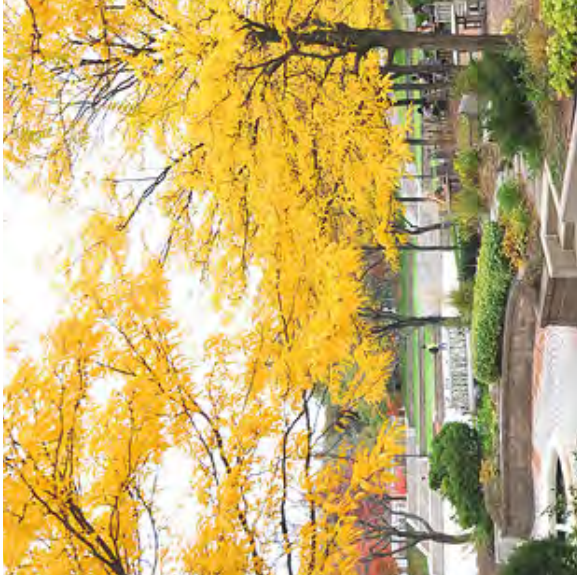

### Stormwater Planters



Dewey Sedge *Carex deweyana*



Soft Rush *Juncus effusus* var. *pacificus*

### Groundplane



Goat's Beard *Aruncus dioicus*



Autumn Fern *Dryopteris erythrosora*

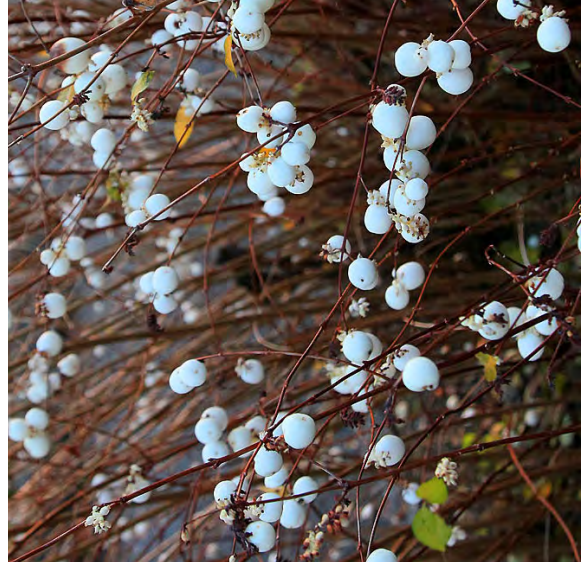

Snowberry *Symphoricarpos albus*



Trillium *Trillium ovatum*

# Courtyard

View to Residential Lobby



# 12th Avenue Building

View from the North

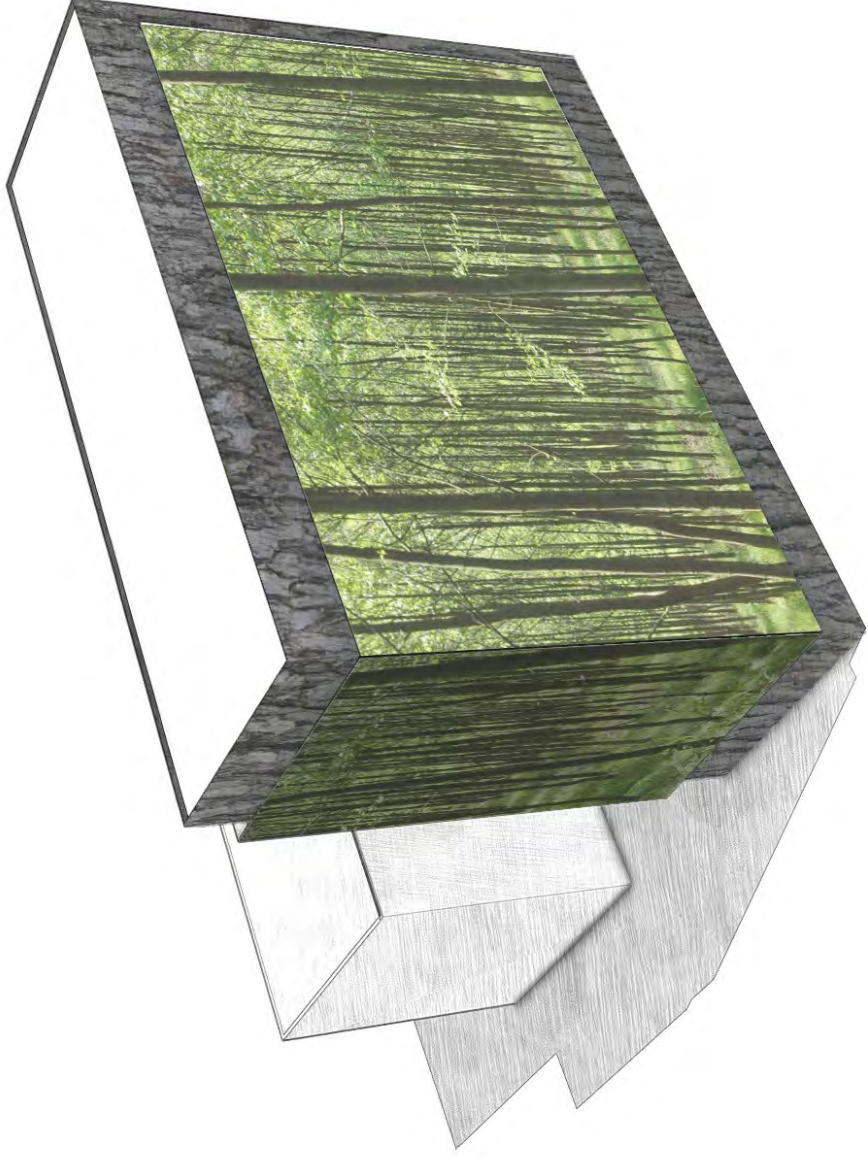

Conceptual Diagram from Southeast

# 12th Avenue Building

## Level 1 Plan

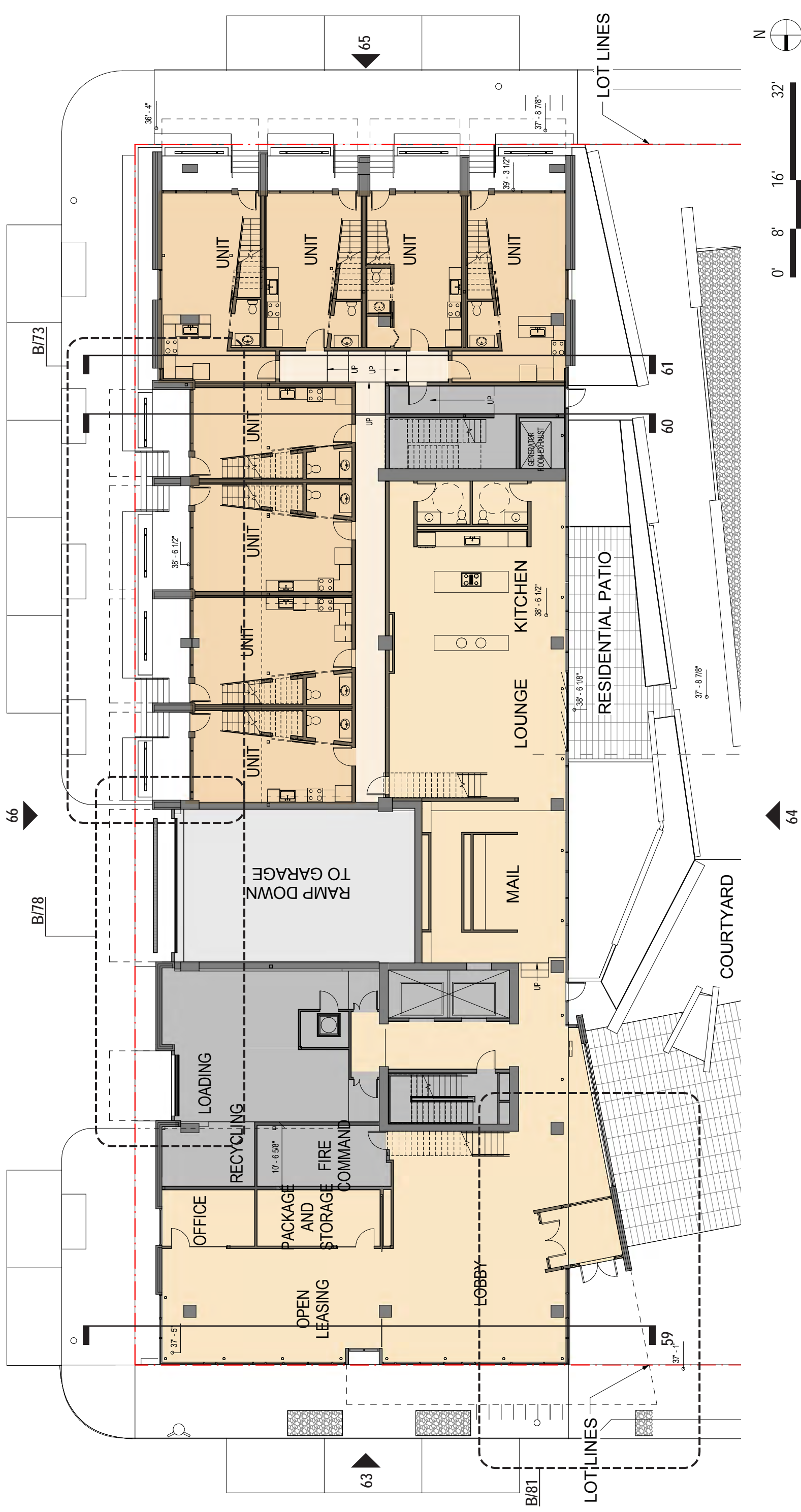

# 12th Avenue Building

Level 2 Plan

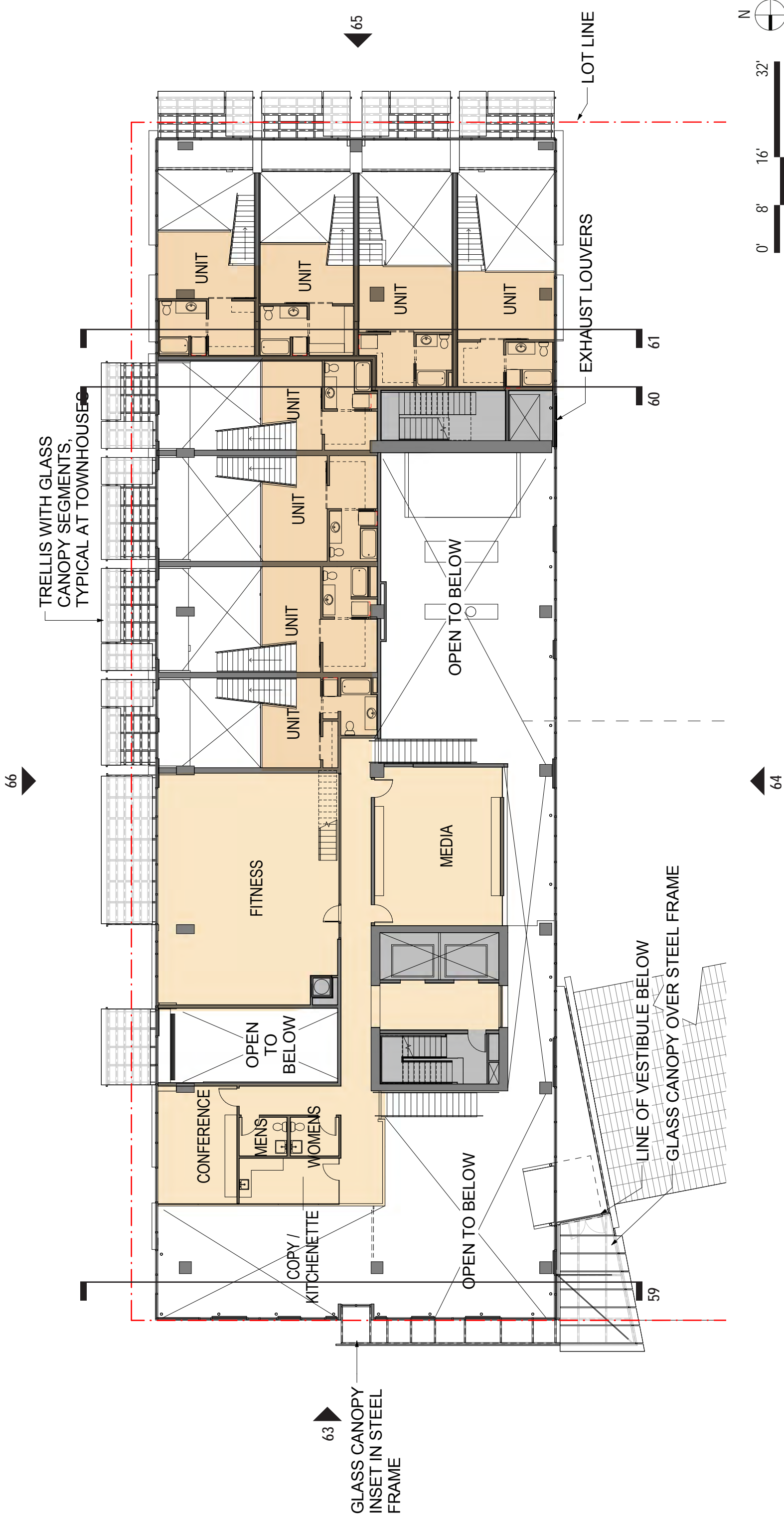

# 12th Avenue Building

## Level 3 Plan

66



63

65

64

0' 8' 16' 32'

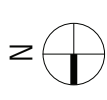

# 12th Avenue Building

## Typical Residential Level Plan

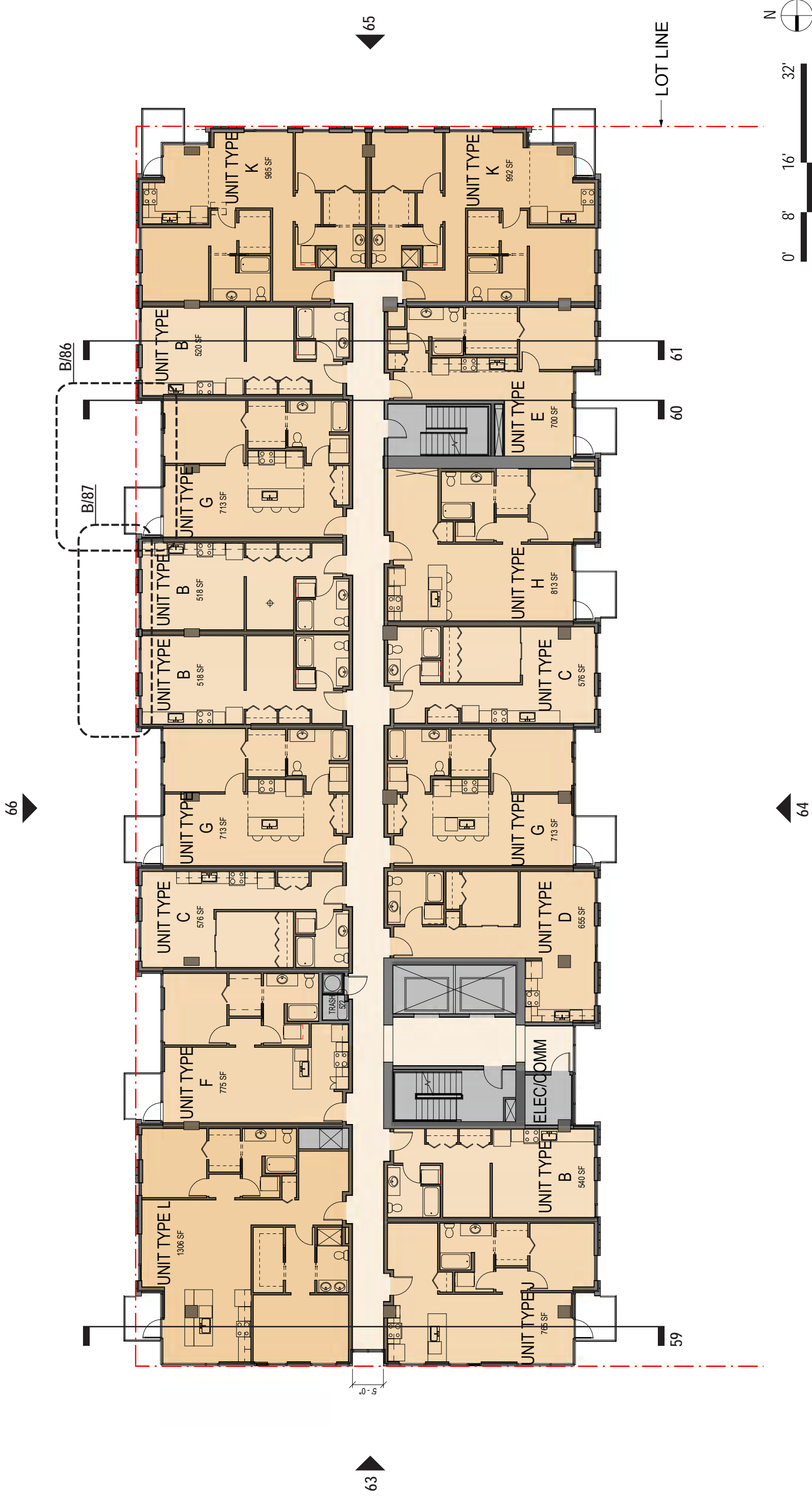

# 12th Avenue Building

## Level 15 Penthouse Plan

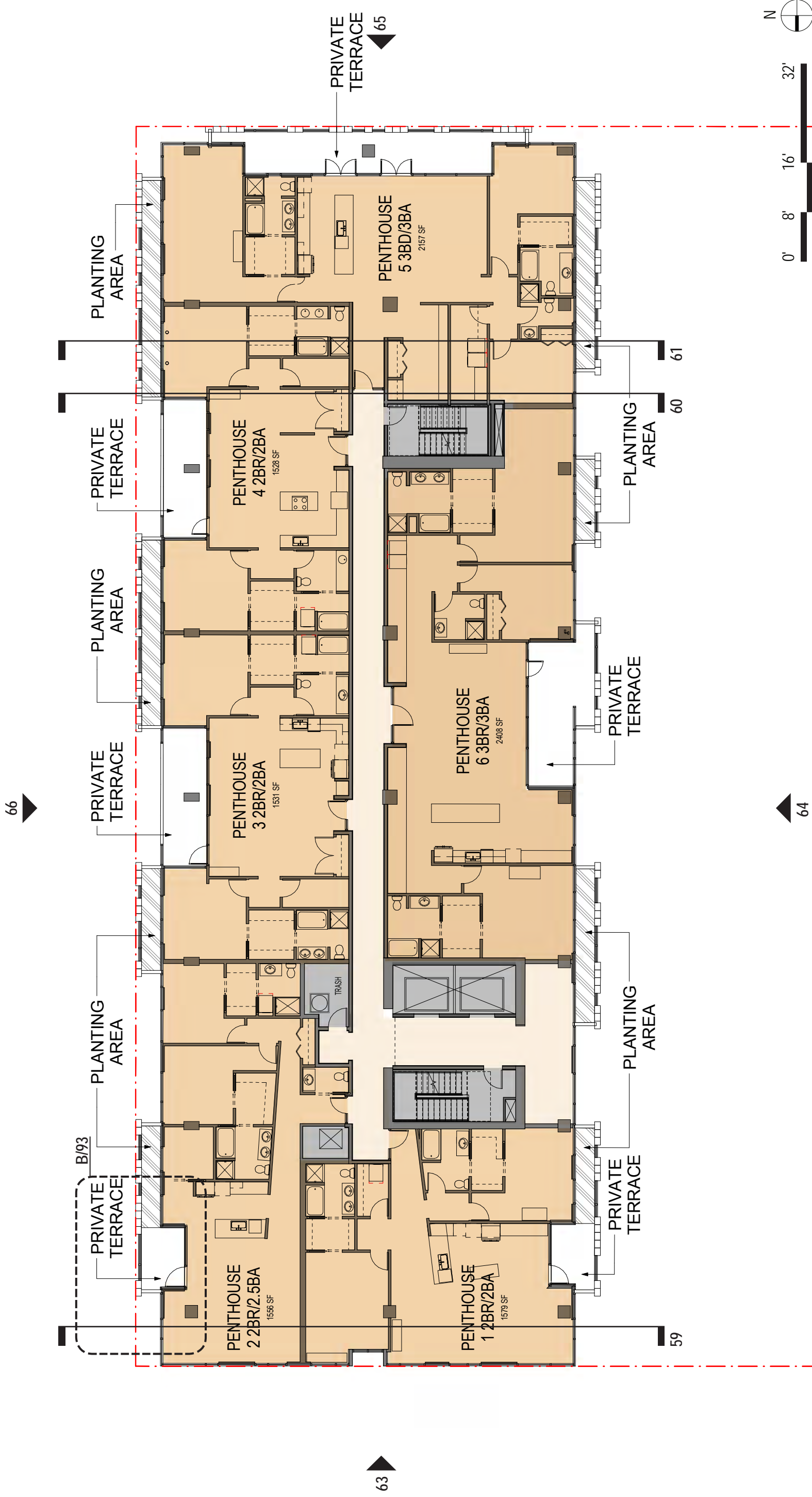



# 12th Avenue Building

## Roof / Mechanical PH Plan

66

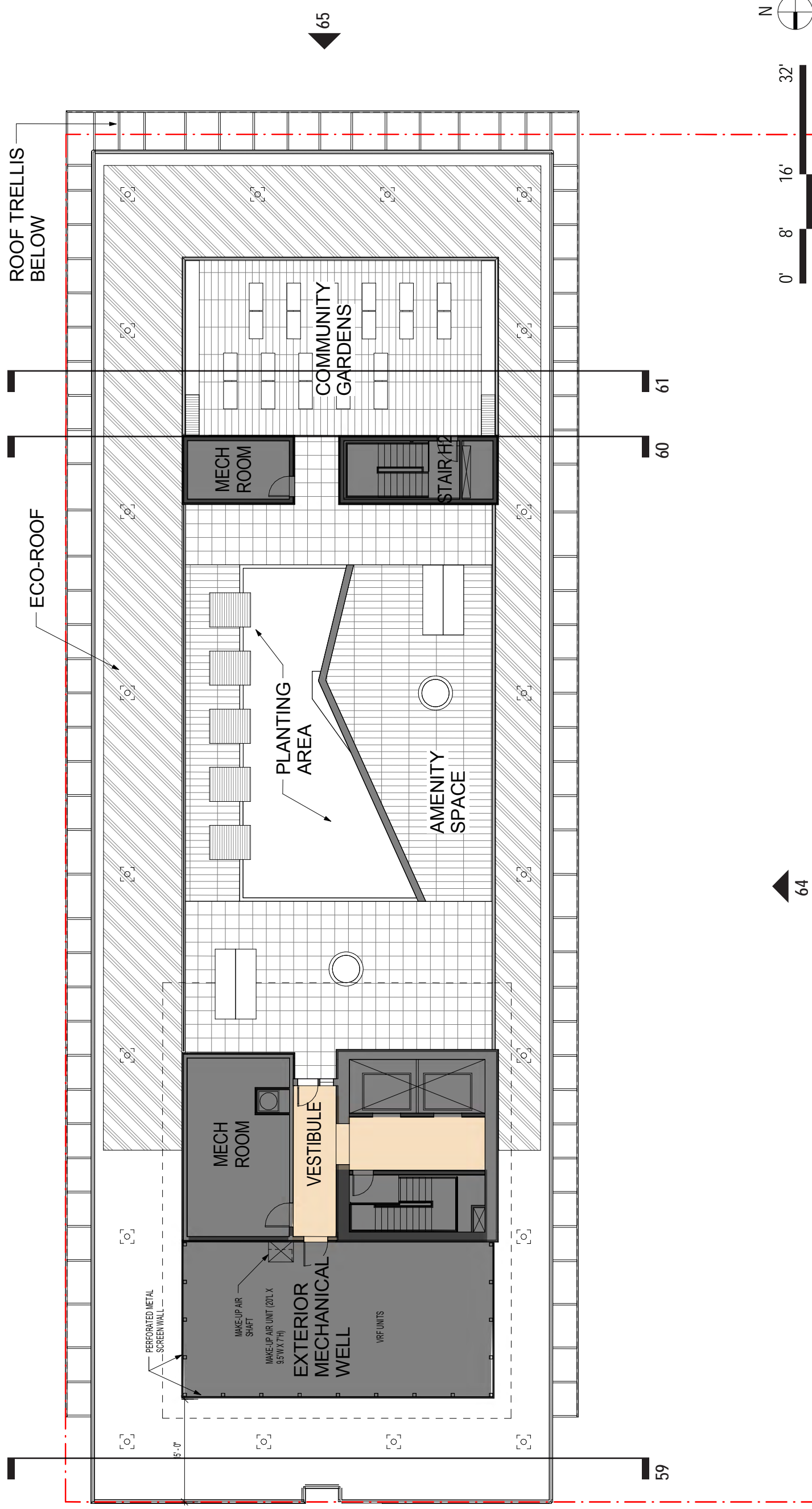

63

64

65

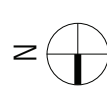

0' 8' 16' 32'

# 12th Avenue Building

Building Section at Window Wall Form

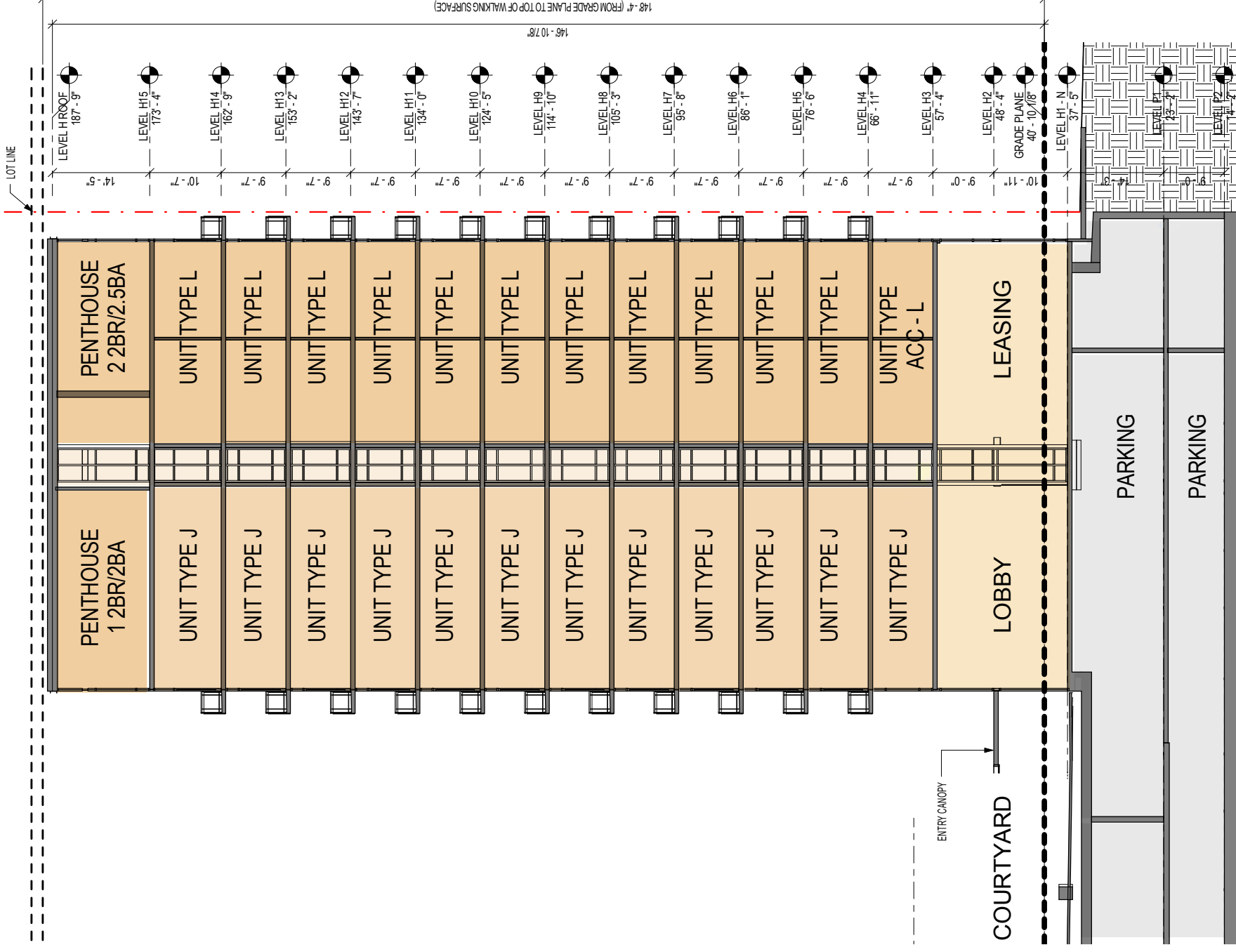

# 12th Avenue Building

Building Section at Townhouses

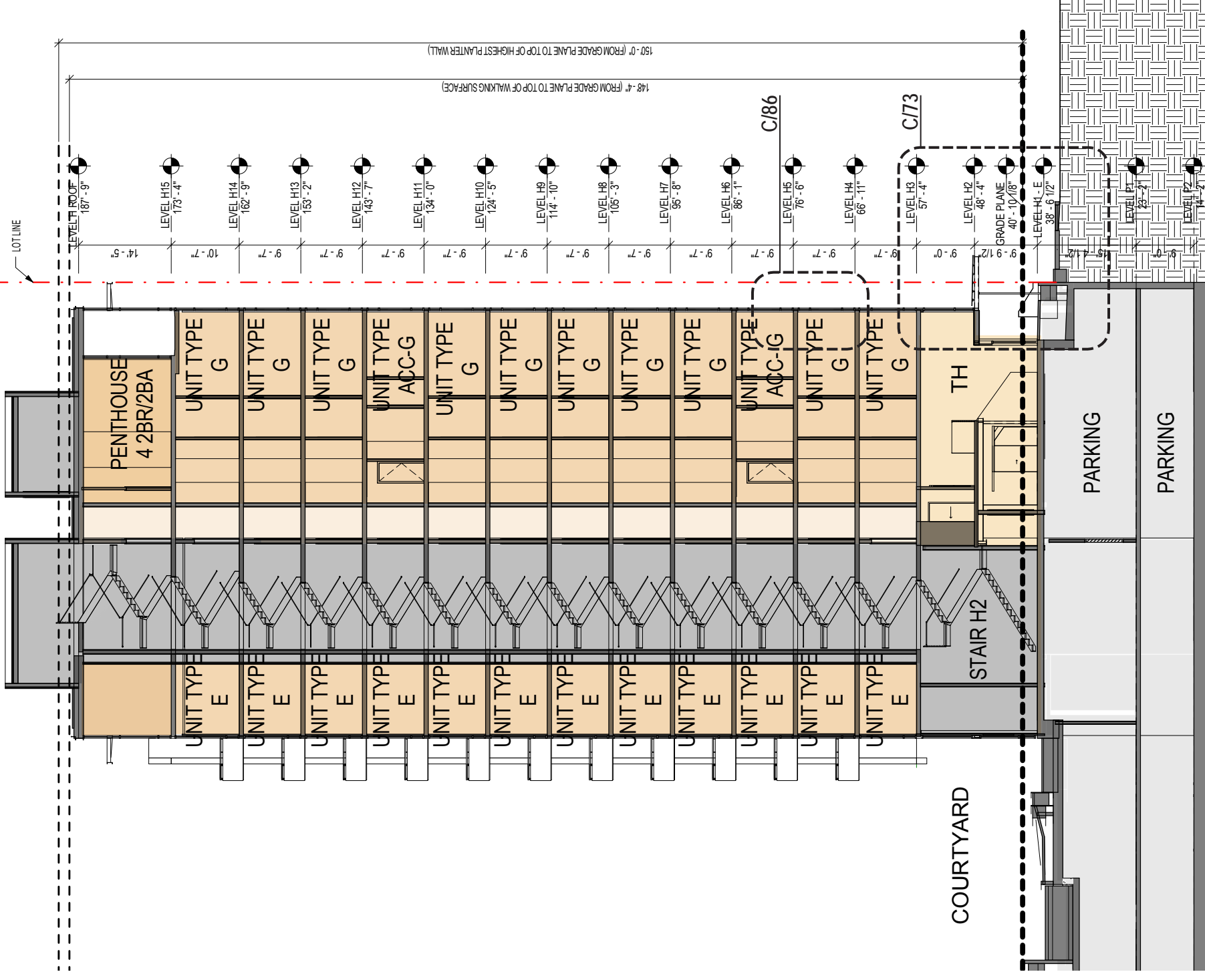

# 12th Avenue Building

## Building Section at Bays

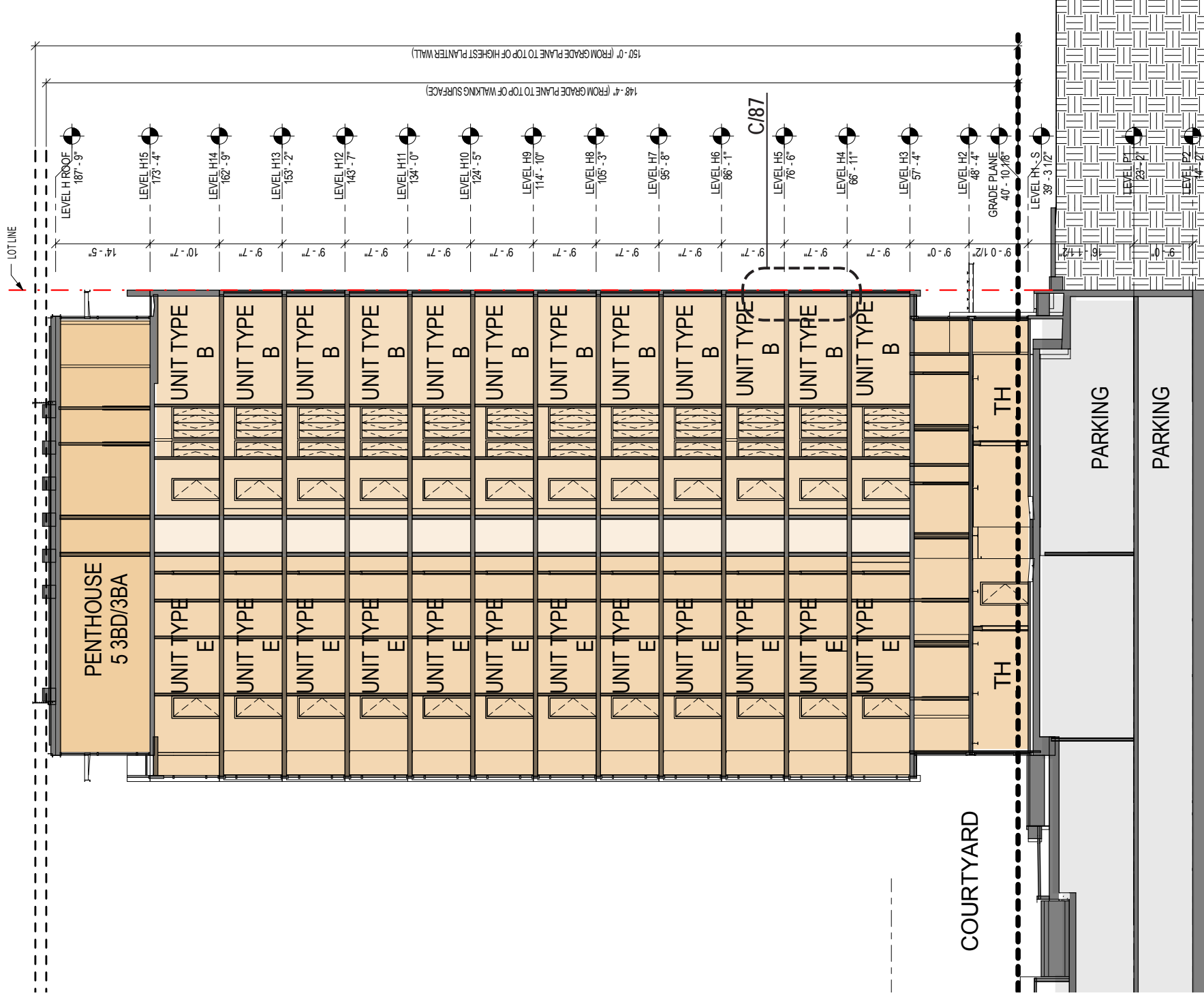

# 12th Avenue Building

Material Photo + Precedents

## Top

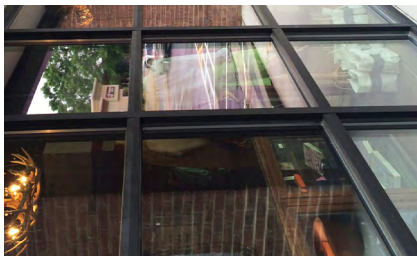

Storefront



Corrugated Metal,  
Medium Grey



Prefin. Parapet  
Cap, Silver

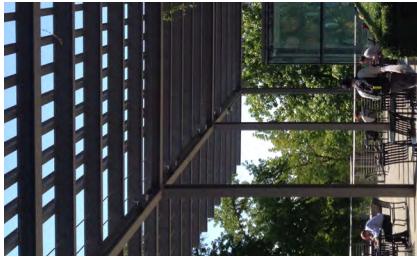

Painted Steel  
Trellis, Silver



Ipe decking



Green roof

## Middle

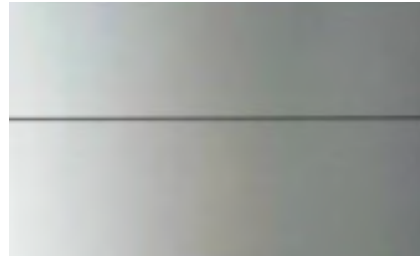

Alum Composite  
Panel, Silver



Window-wall +  
Spandrel



Glass and Pre-  
finished Alum  
Railing

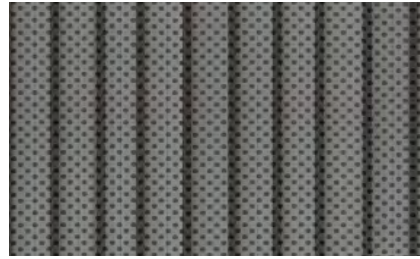

Perforated  
Corrugated Metal

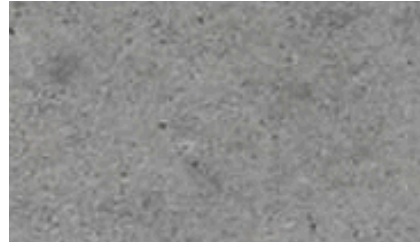

Concrete  
Balconies

## Bottom

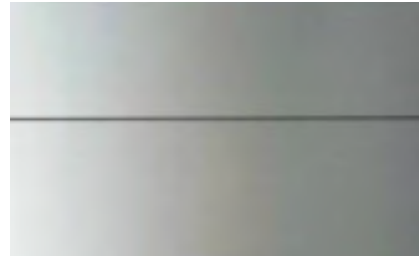

Alum Composite  
Panel, Silver



Board-Formed  
Concrete

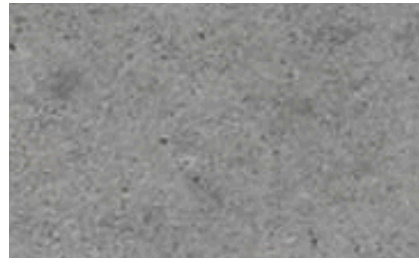

Concrete

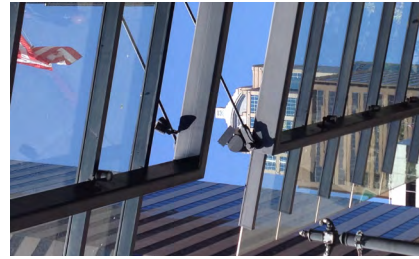

Painted Structure

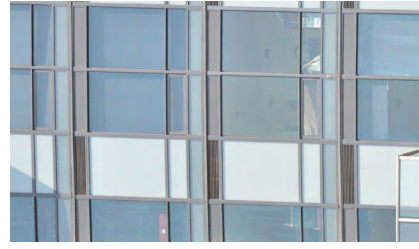

Window-wall +  
Spandrel

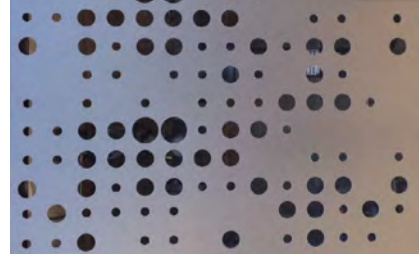

Perforated Metal  
Screens

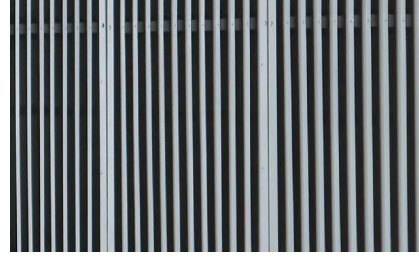

Metal Louvers



Painted Color  
Accent Door

# 12th Avenue Building

## North Elevation

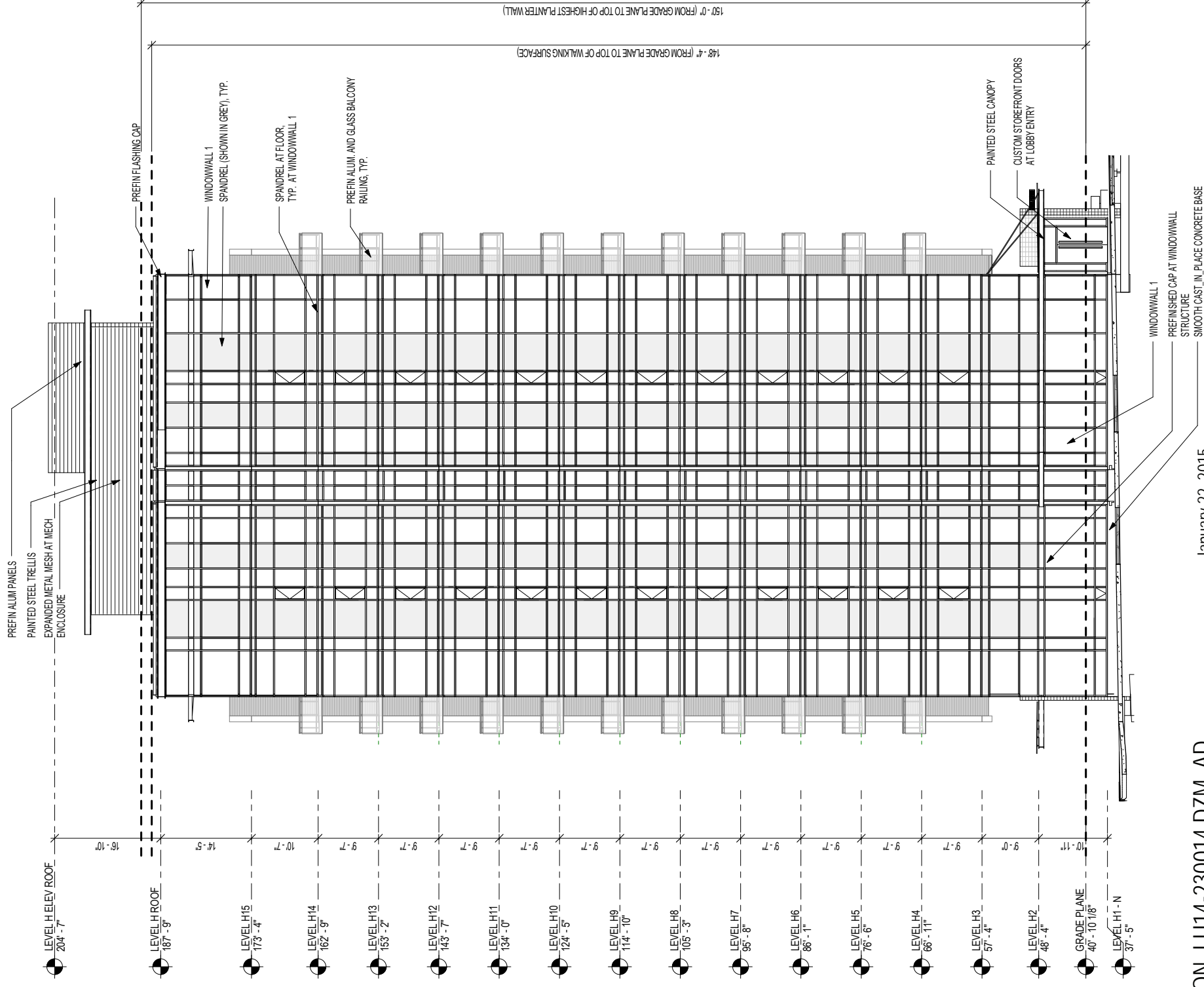

Level	Height
LEVEL H ELEV. ROOF	204'-7"
LEVEL H ROOF	187'-9"
LEVEL H15	173'-4"
LEVEL H14	162'-9"
LEVEL H13	153'-2"
LEVEL H12	143'-7"
LEVEL H11	134'-0"
LEVEL H10	124'-5"
LEVEL H9	114'-10"
LEVEL H8	105'-3"
LEVEL H7	95'-8"
LEVEL H6	86'-1"
LEVEL H5	76'-6"
LEVEL H4	66'-11"
LEVEL H3	57'-4"
LEVEL H2	48'-4"
GRADE PLANE	40'-10 1/8"
LEVEL H1 - N	37'-5"

# 12th Avenue Building

## West Elevation at Courtyard

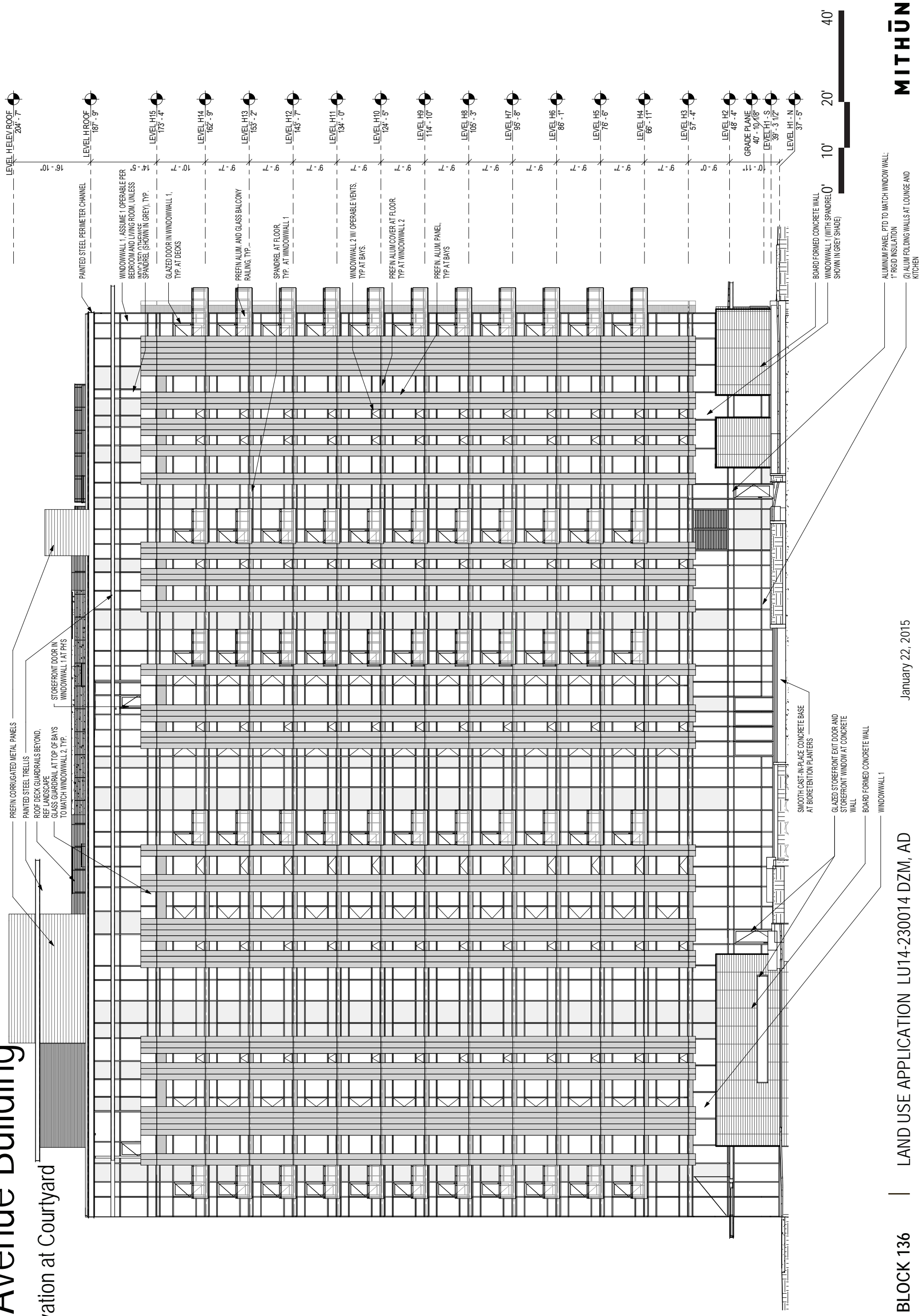

# 12th Avenue Building

## South Elevation

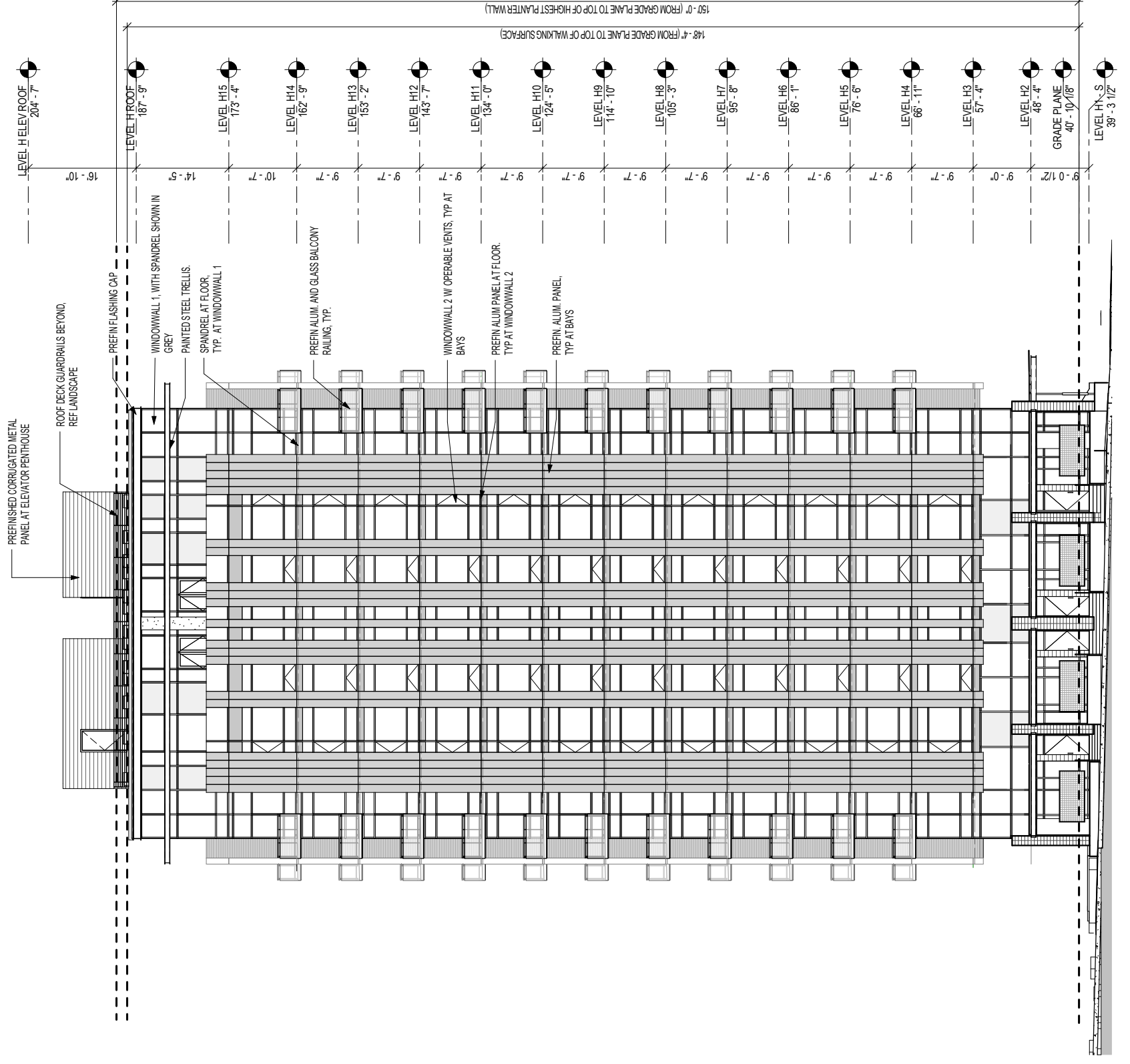



# 12th Avenue Building

East Elevation at 12th Avenue

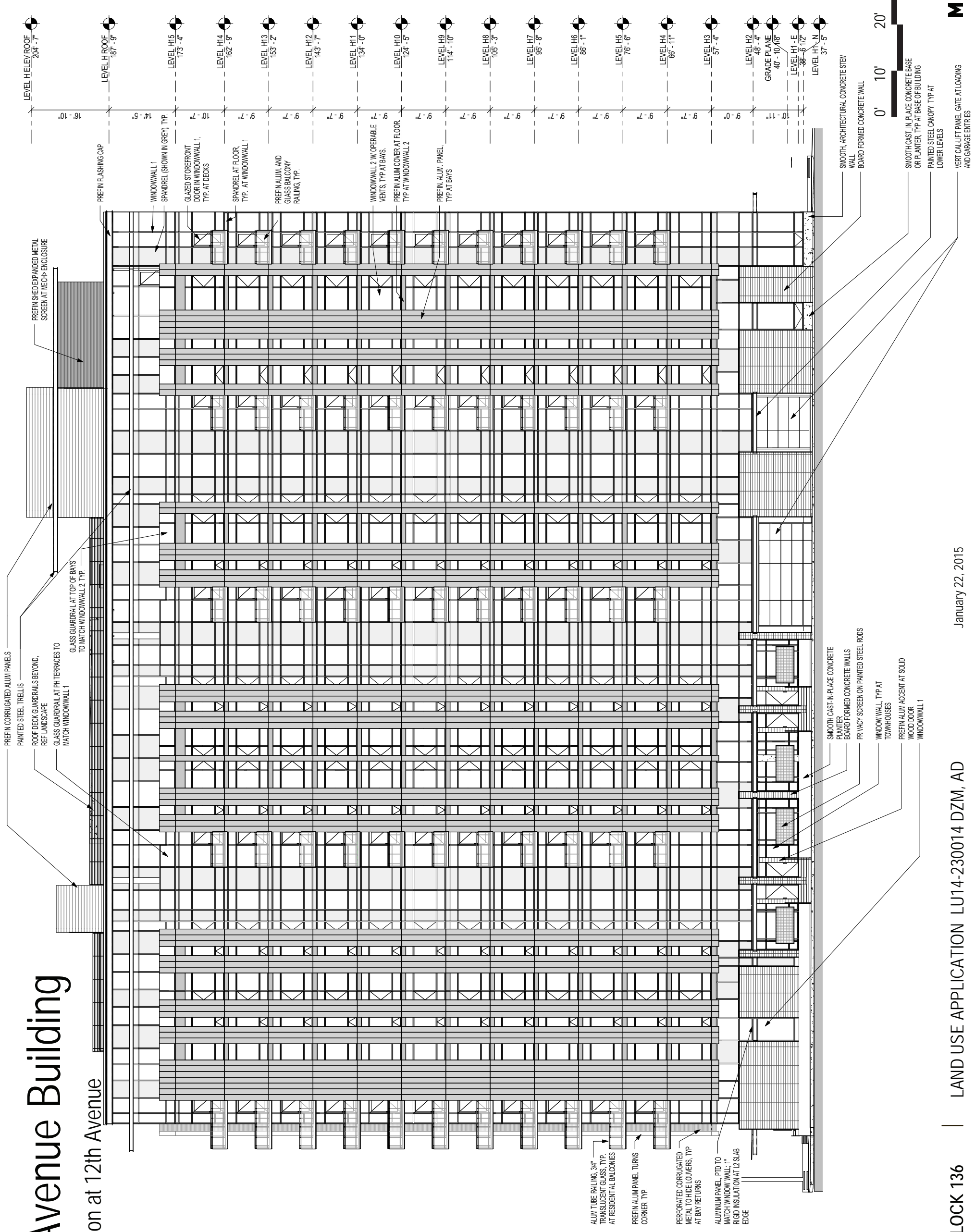

# 12th Avenue Building Details

## Pearl District Townhouse Context

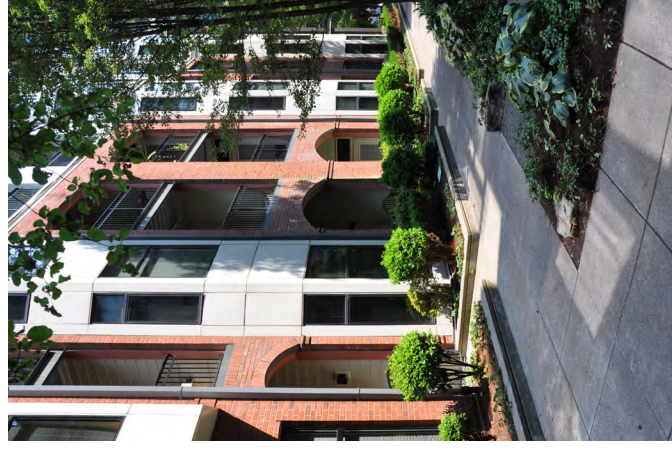
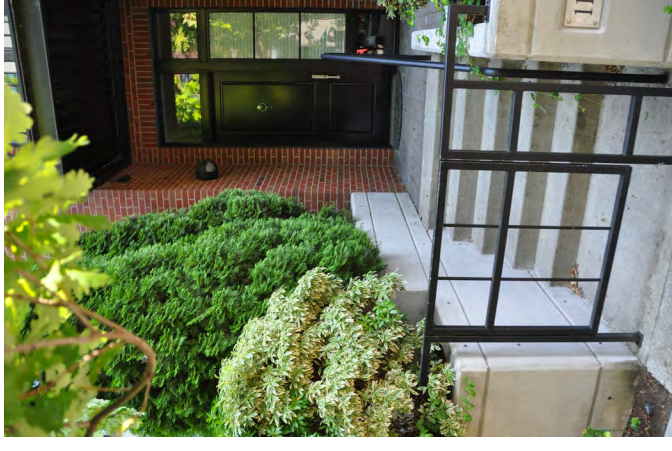
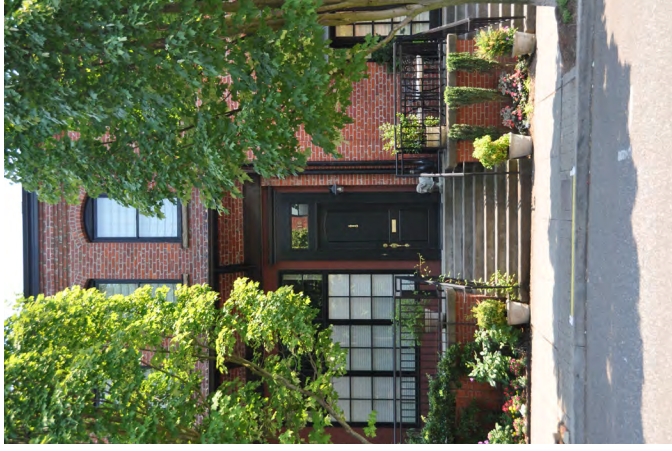
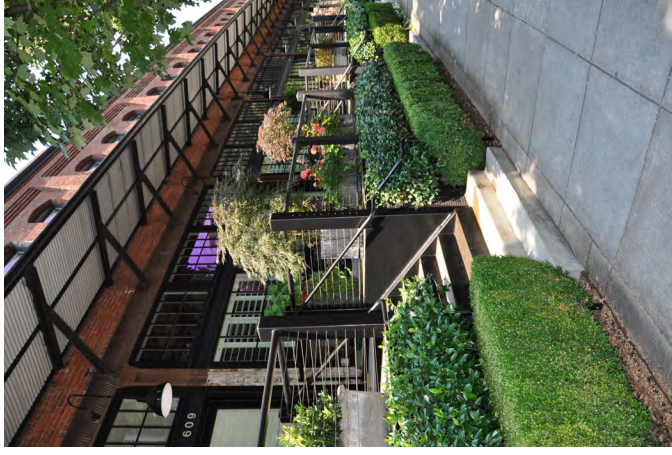

### Townhouse Principles

- Define the individual residence
- Elevate the townhouse above the street
- Provide individual entries and stairs from the sidewalk
- Buffer the townhouse from the sidewalk with two level planters
- Create patios with privacy element through planting or screening
- Create detail through canopies, railings, or similar methods

# 12th Avenue Building Details

## Board-Formed Concrete

### Board-Formed Strategy:

- Formed with highly-textured salvaged lumber (no formliner)
- 2x6 boards, horizontally laid
- Gaps between boards to achieve raw horizontal lines
- Mock-up using garage walls until desired look is achieved



Existing PNCA painted concrete



1/4" gaps between form boards to create rough, protruding ribs

Salvaged form boards: 2x4 shown 2x6 proposed

Sample of proposed board-formed concrete (REI Flagship store by Mithun)

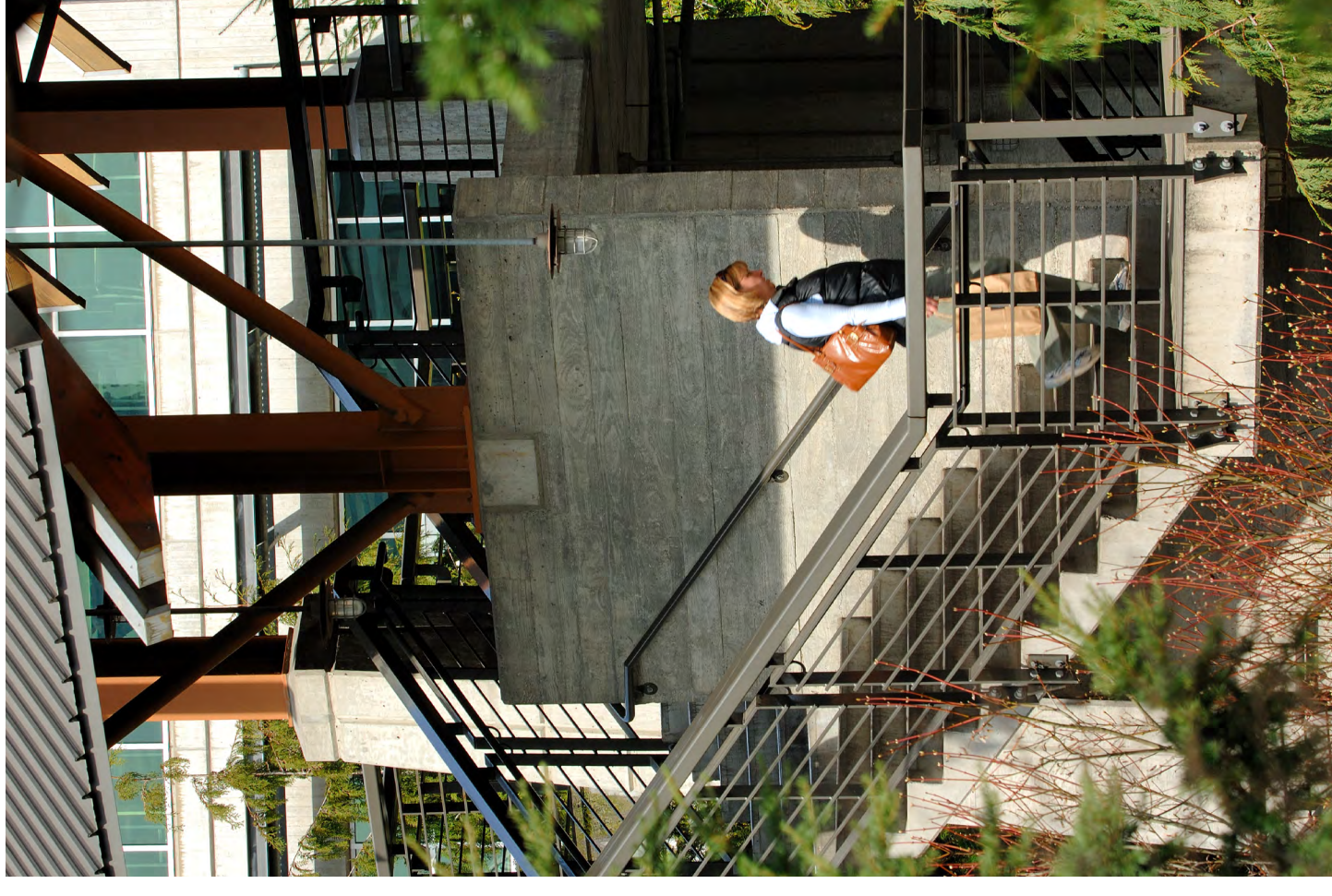

Precedent of proposed board-formed concrete (REI Flagship store by Mithun)

# 12th Avenue Building Details

Townhouses on Johnson Street



# 12th Avenue Building Details

## Townhouse Streetscape Plan

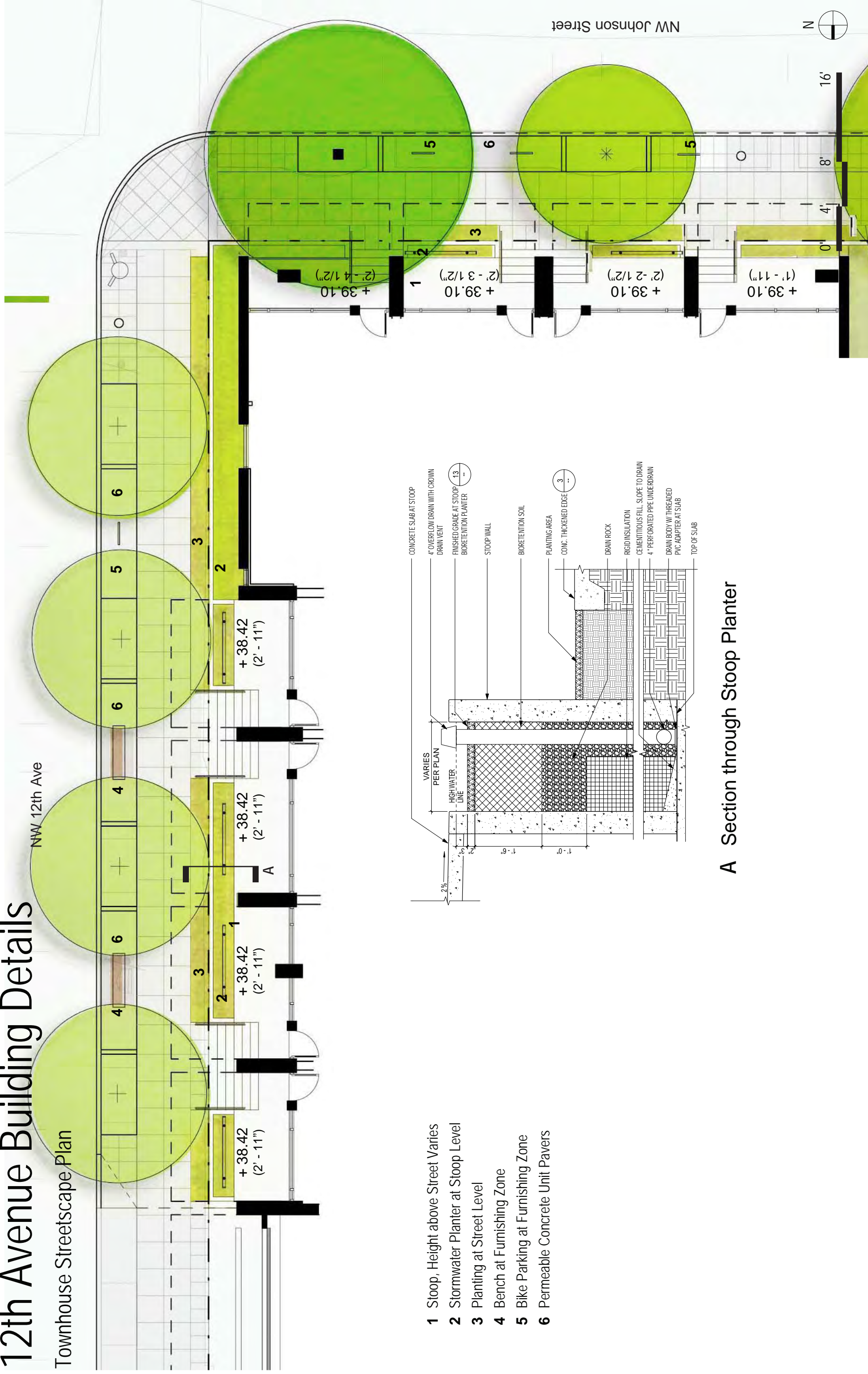

- 1 Stoop, Height above Street Varies
- 2 Stormwater Planter at Stoop Level
- 3 Planting at Street Level
- 4 Bench at Furnishing Zone
- 5 Bike Parking at Furnishing Zone
- 6 Permeable Concrete Unit Pavers

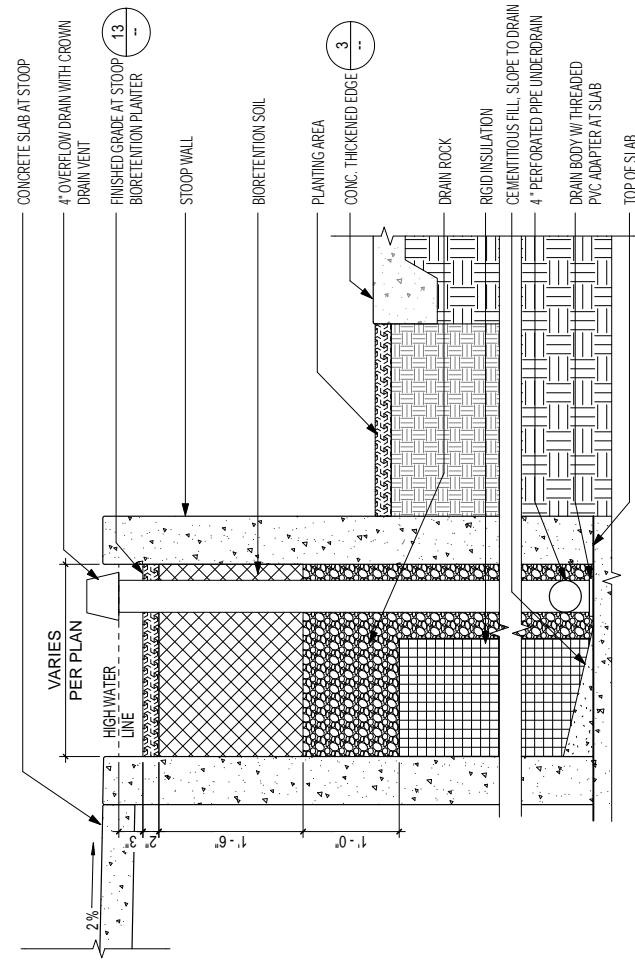

A Section through Stoop Planter

# 12th Avenue Building Details

Townhouses on 12th Ave and Johnson Street



# 12th Avenue Building Details

Ground Level at 12th Avenue

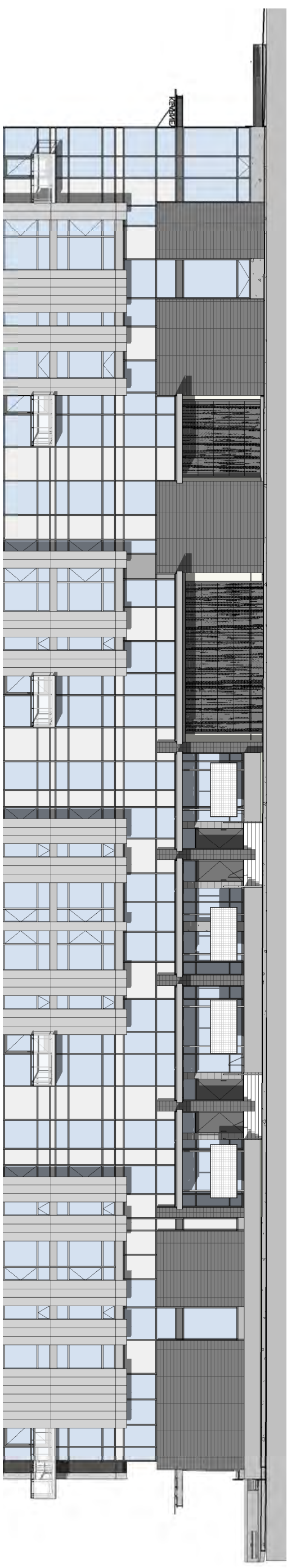

A East Elevation at NW 12th Avenue

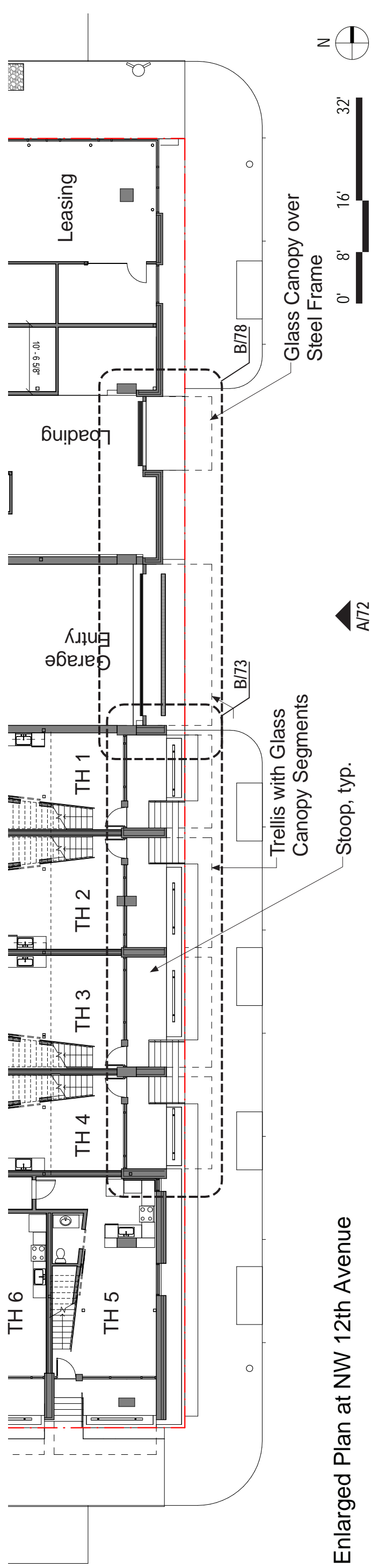

B Enlarged Plan at NW 12th Avenue

# 12th Avenue Building Details

Townhouses (Shown at 12th Avenue)

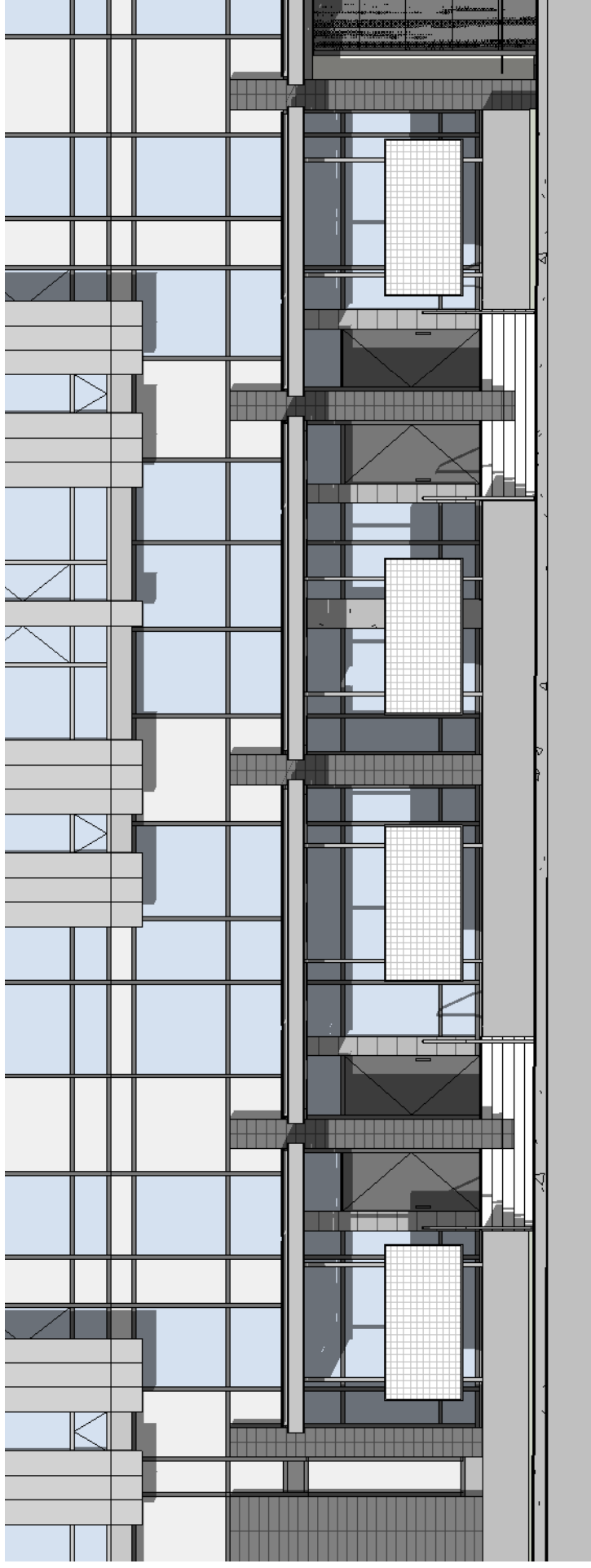

A Elevation at 12th Avenue Townhouses

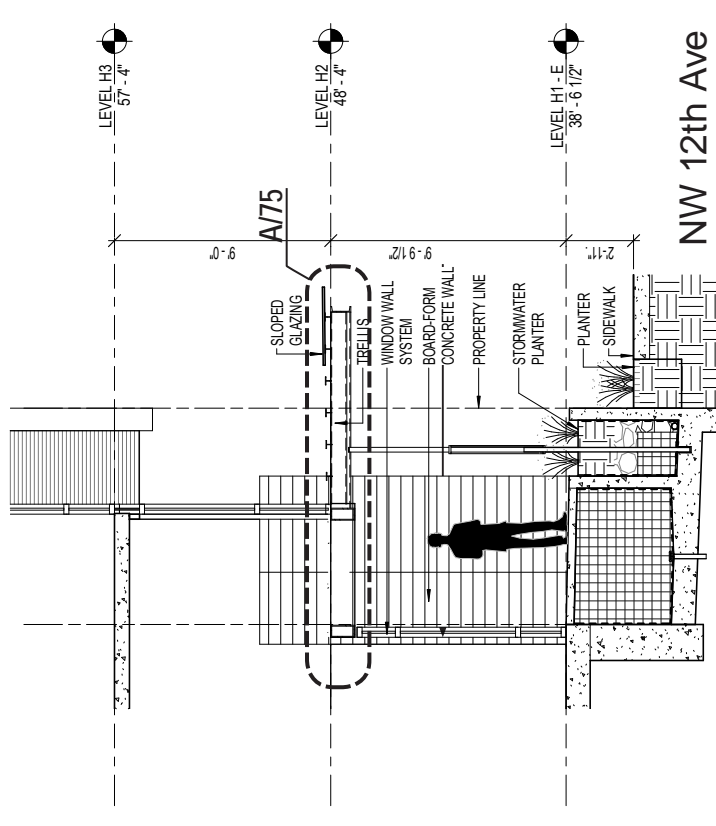

C Section at NW 12th Ave

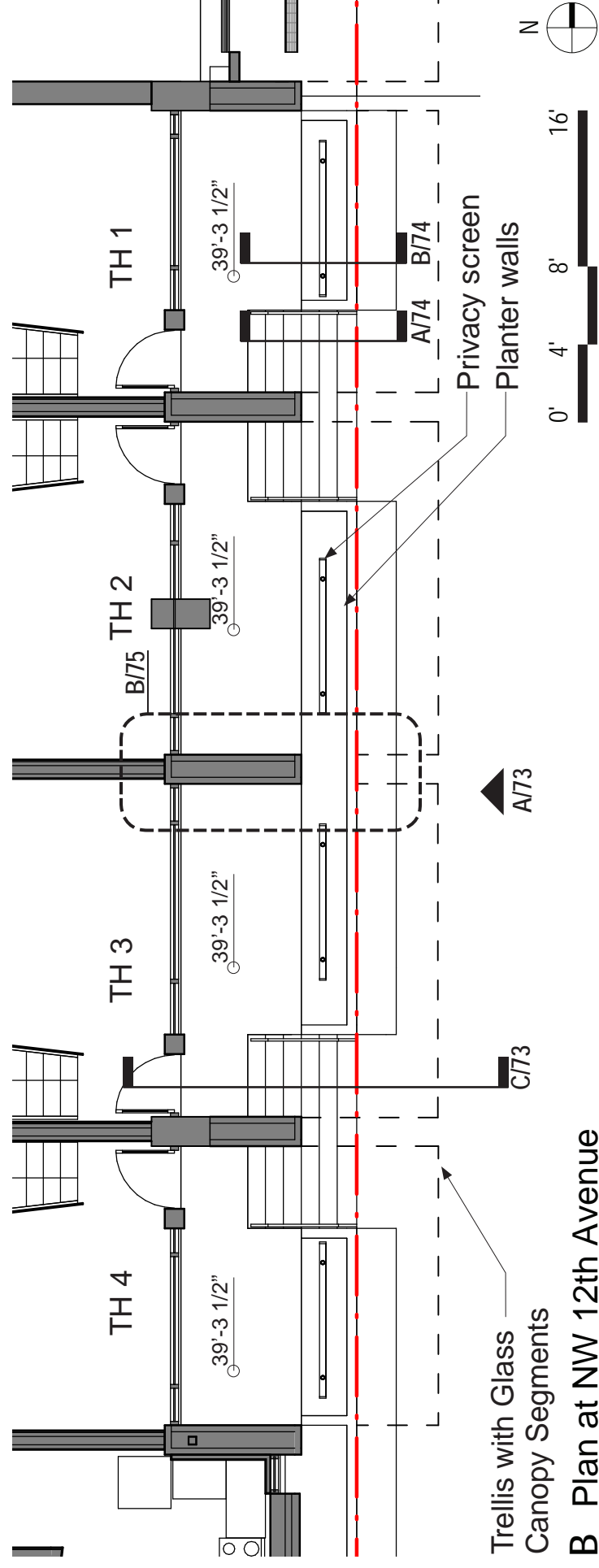

B Plan at NW 12th Avenue



# 12th Avenue Building Details

Townhouses (Shown at 12th Avenue)



Board - Formed Concrete

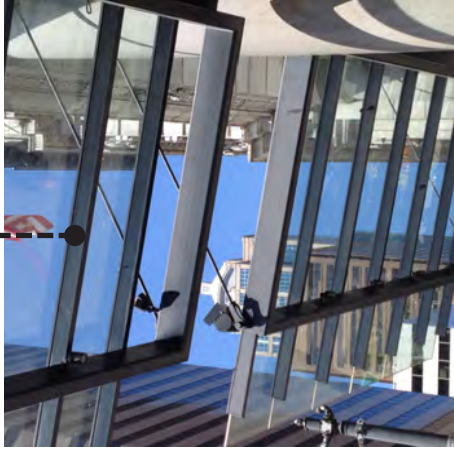

Painted Steel



Window Wall

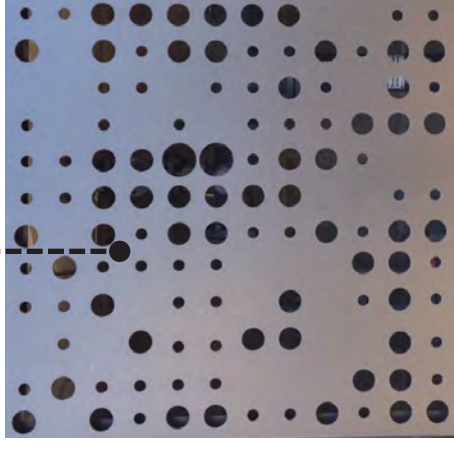

Mesh

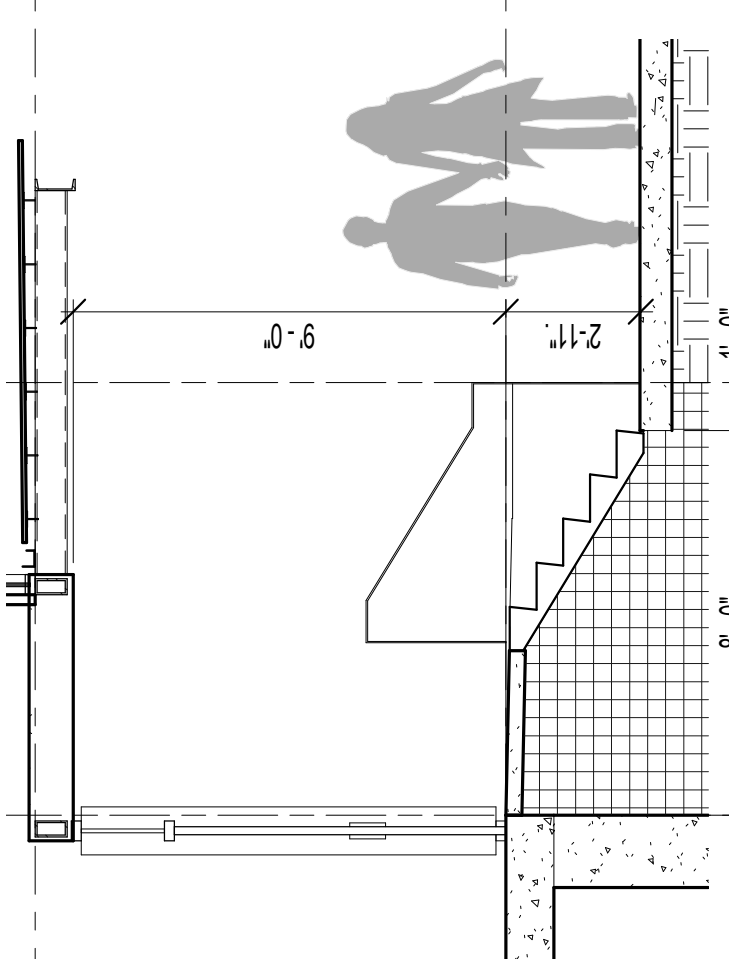

A Section through Stair

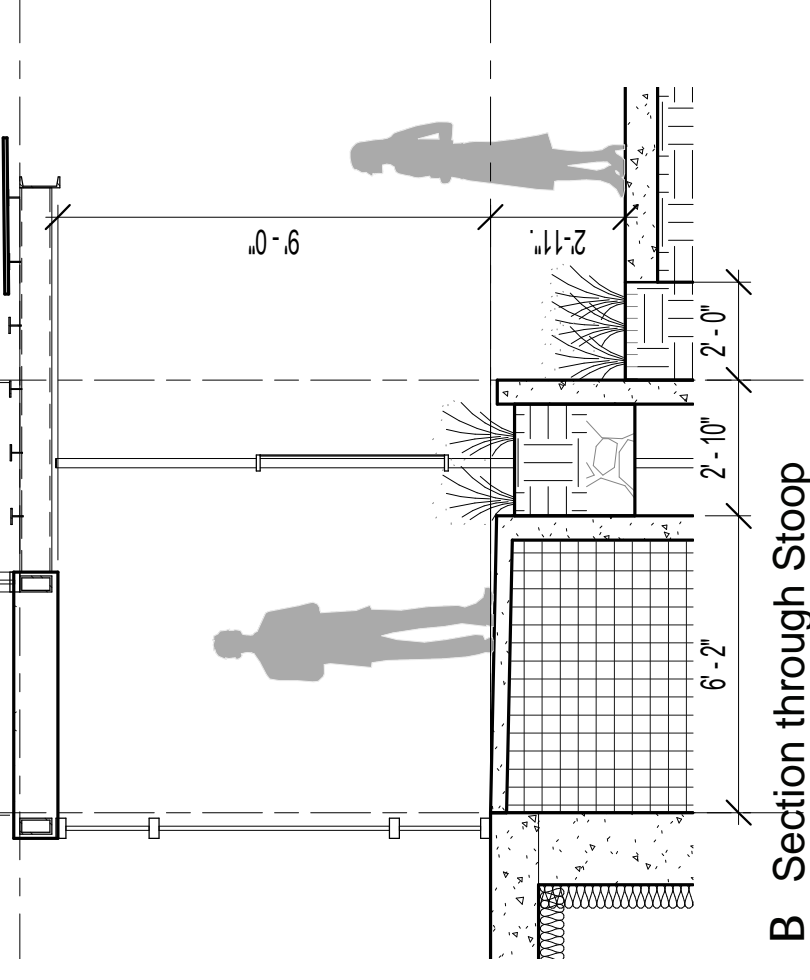

B Section through Stoop

# 12th Avenue Building Details

## Townhouse Canopy Detail

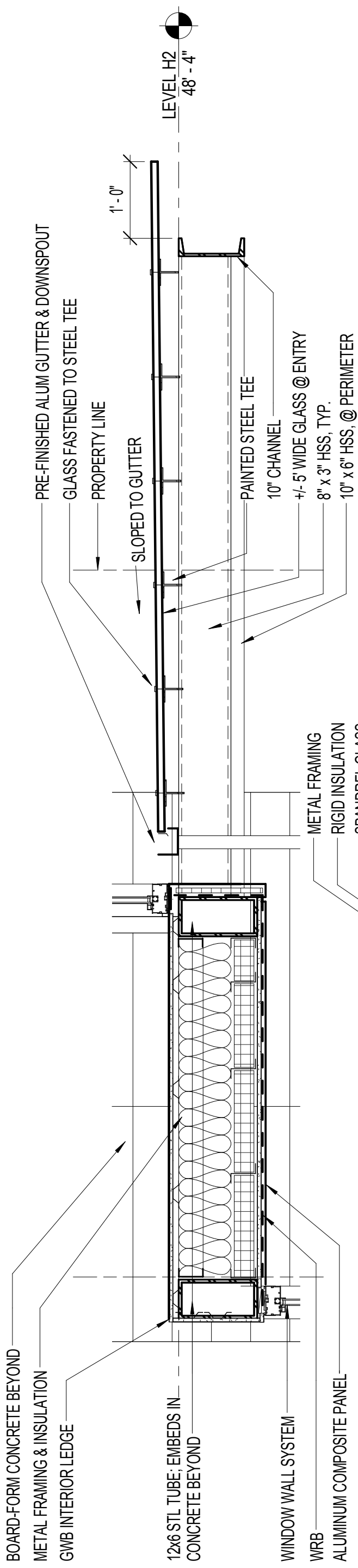

## A Section through Canopy

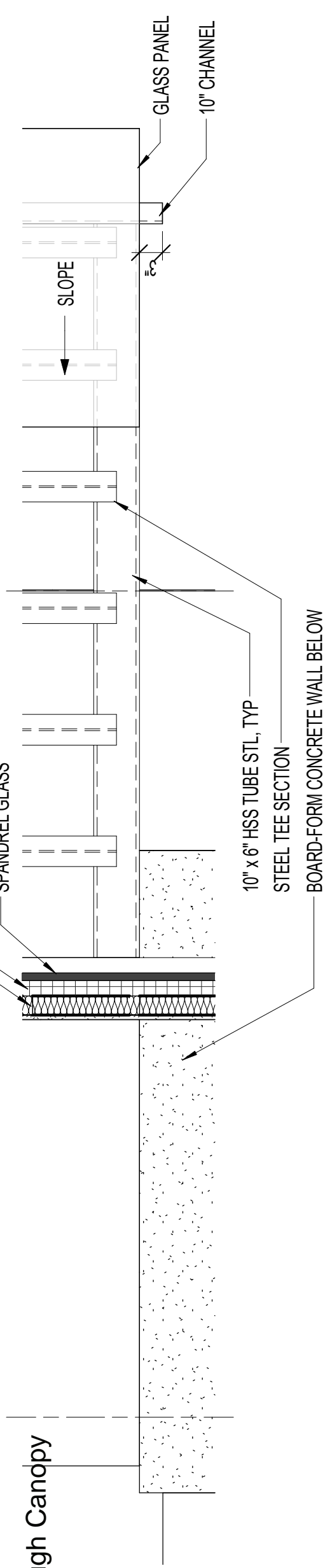

## B Detail Plan

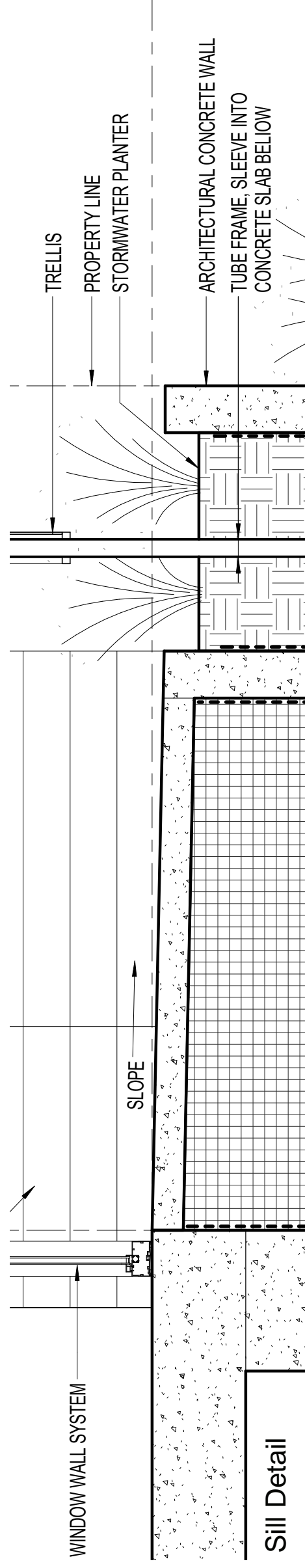

## C Sill Detail

# 12th Avenue Building Details

Townhouses



# 12th Avenue Building Details

Pearl District Garage Entry Context

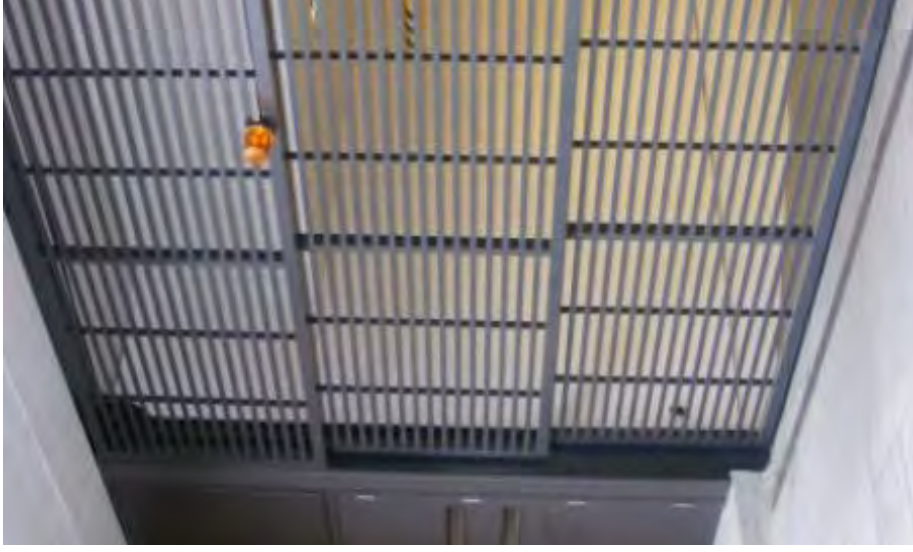

# 12th Avenue Building Details

Garage and Loading Entries on 12th Avenue

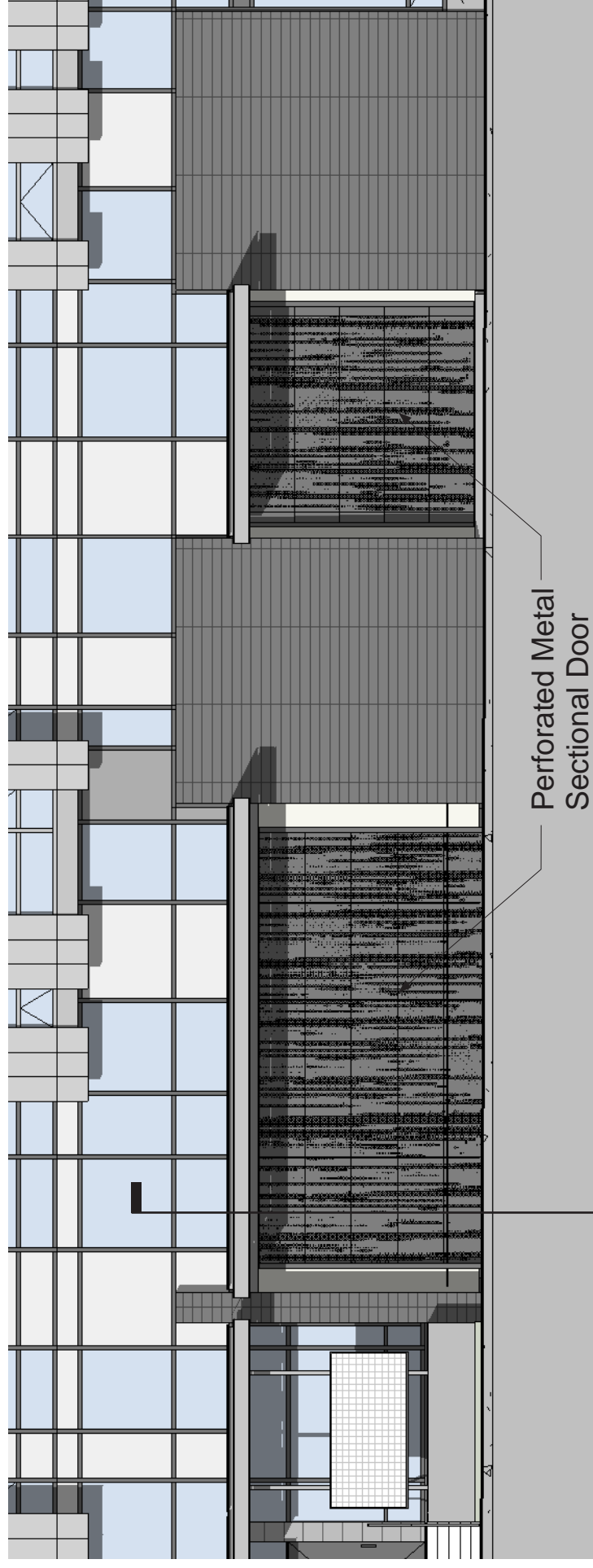

A Elevation at Garage and Loading Entries

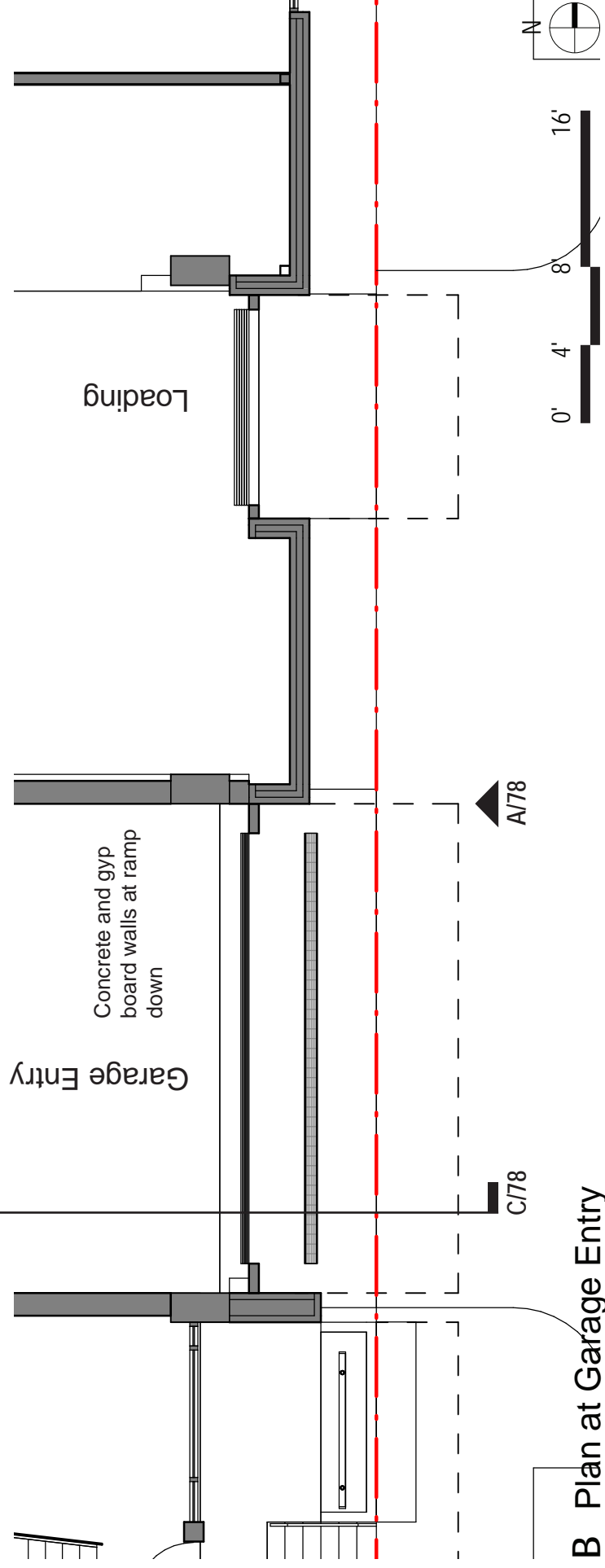

B Plan at Garage Entry

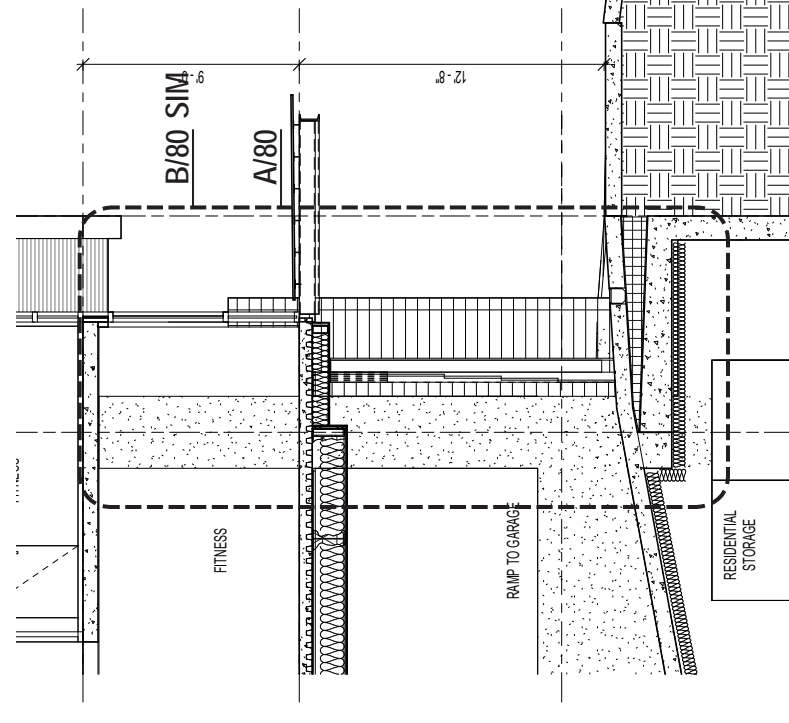

C Section at Garage and Loading Entries

# 12th Avenue Building Details

Garage Entry on 12th Avenue



Sapling Forest

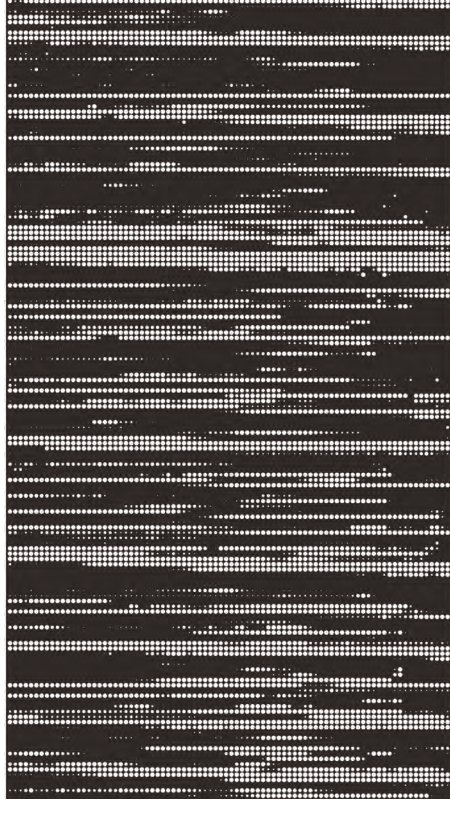

Perforated Metal Pattern at Garage Entry Door



Board - Formed Concrete

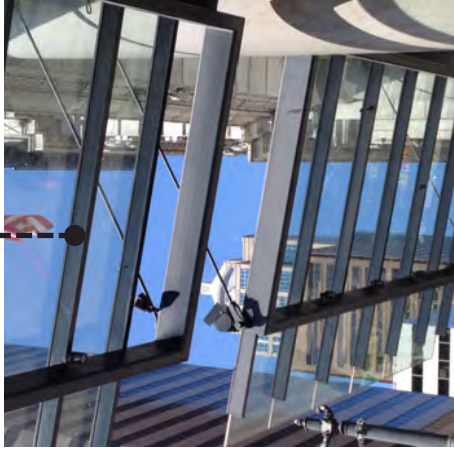

Painted Steel



Planting



Garage Entry Door

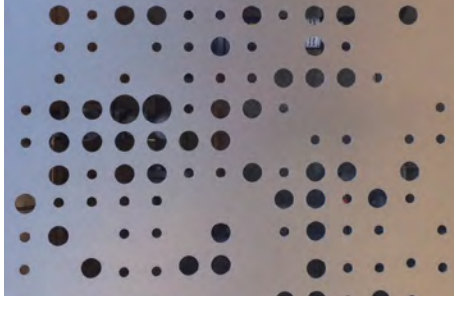

Garage Entry

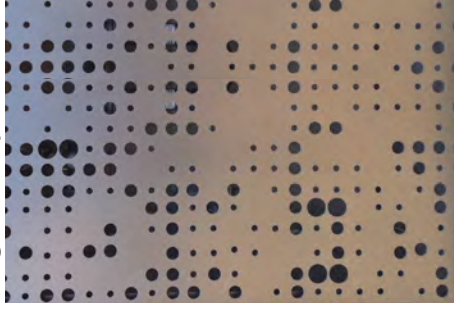

Loading Entry with tighter perforation pattern

# 12th Avenue Building Details

## Garage Entry Canopy Details

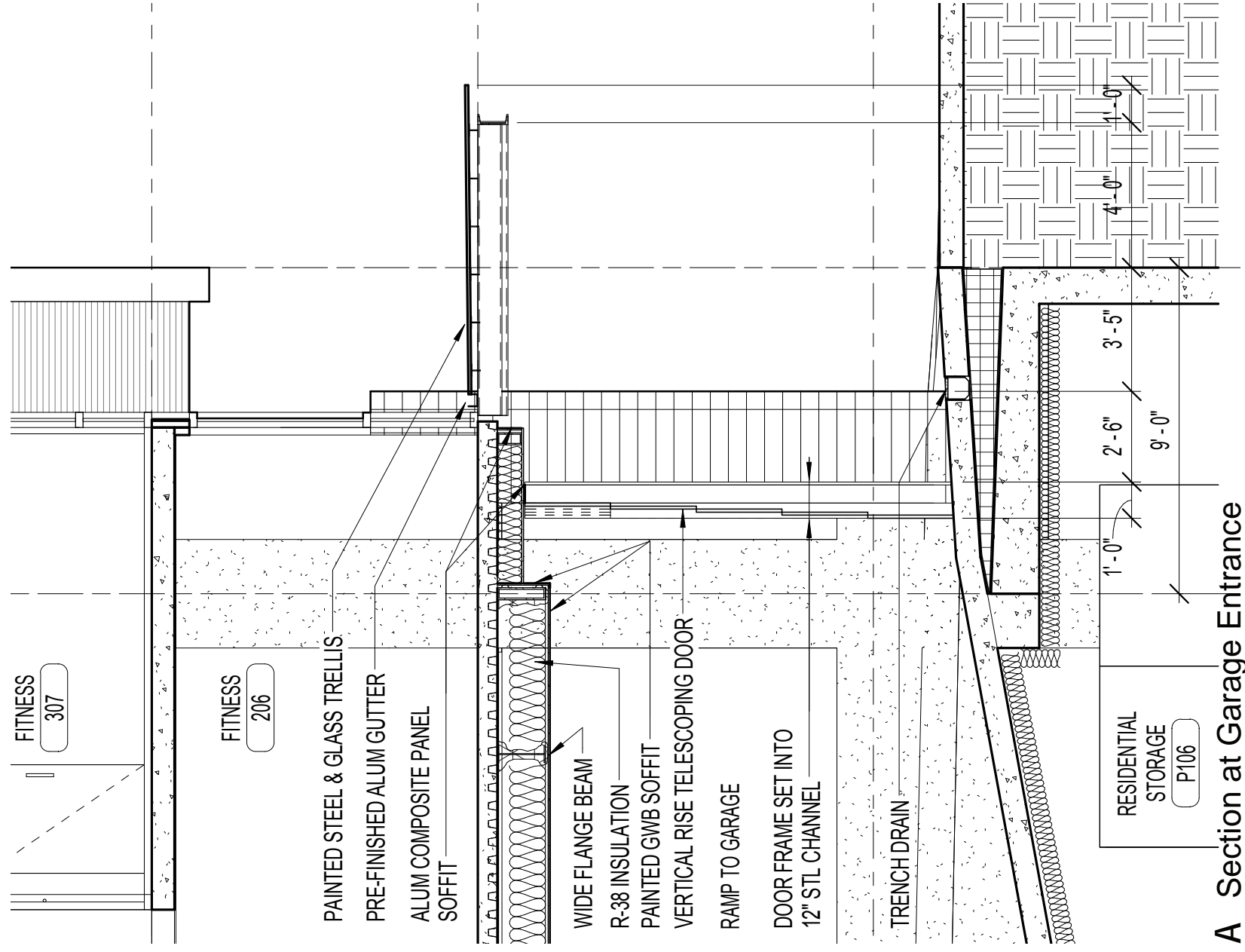

**A Section at Garage Entrance**

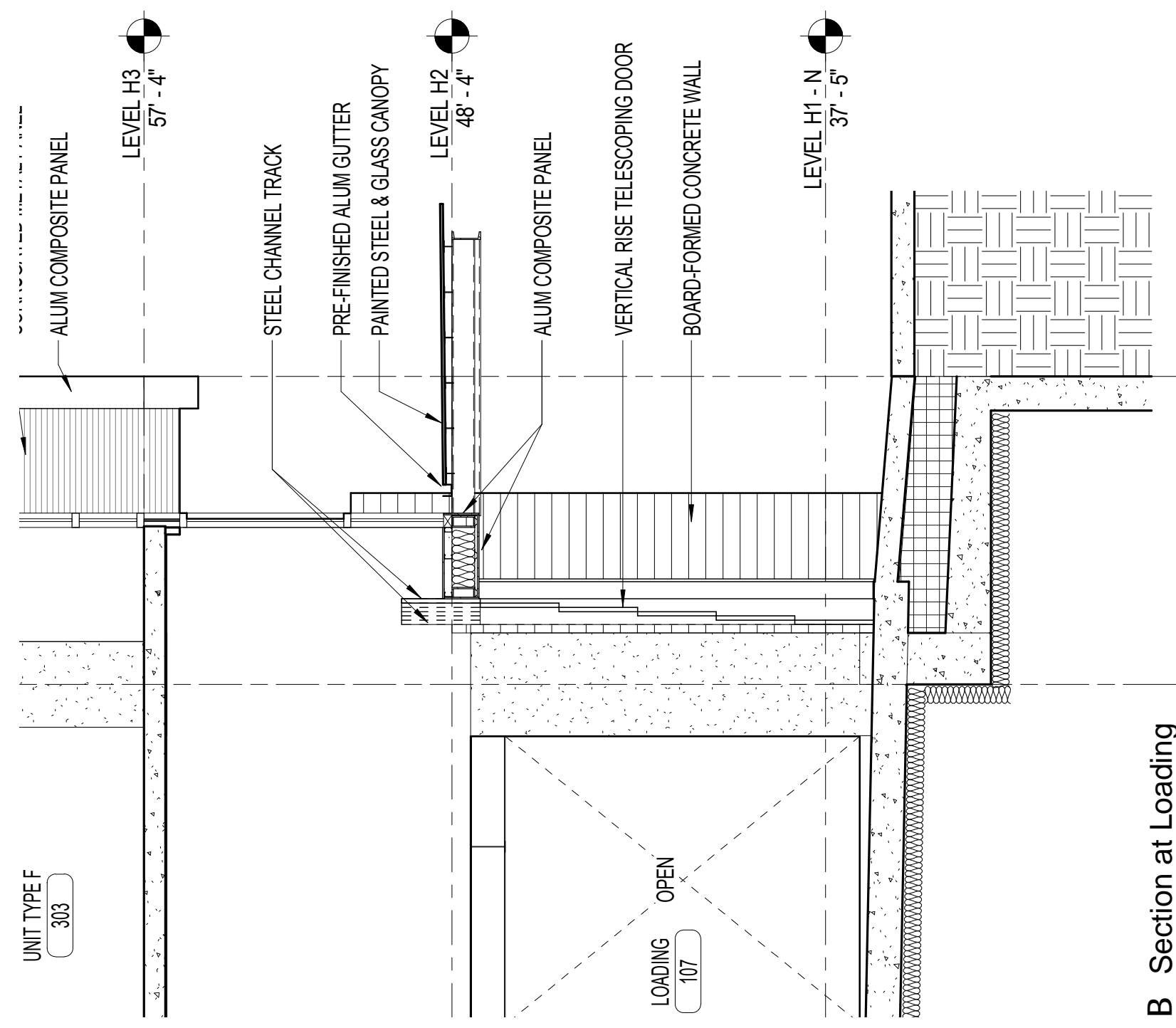

**B Section at Loading**

# 12th Avenue Building Details

Residential Entry

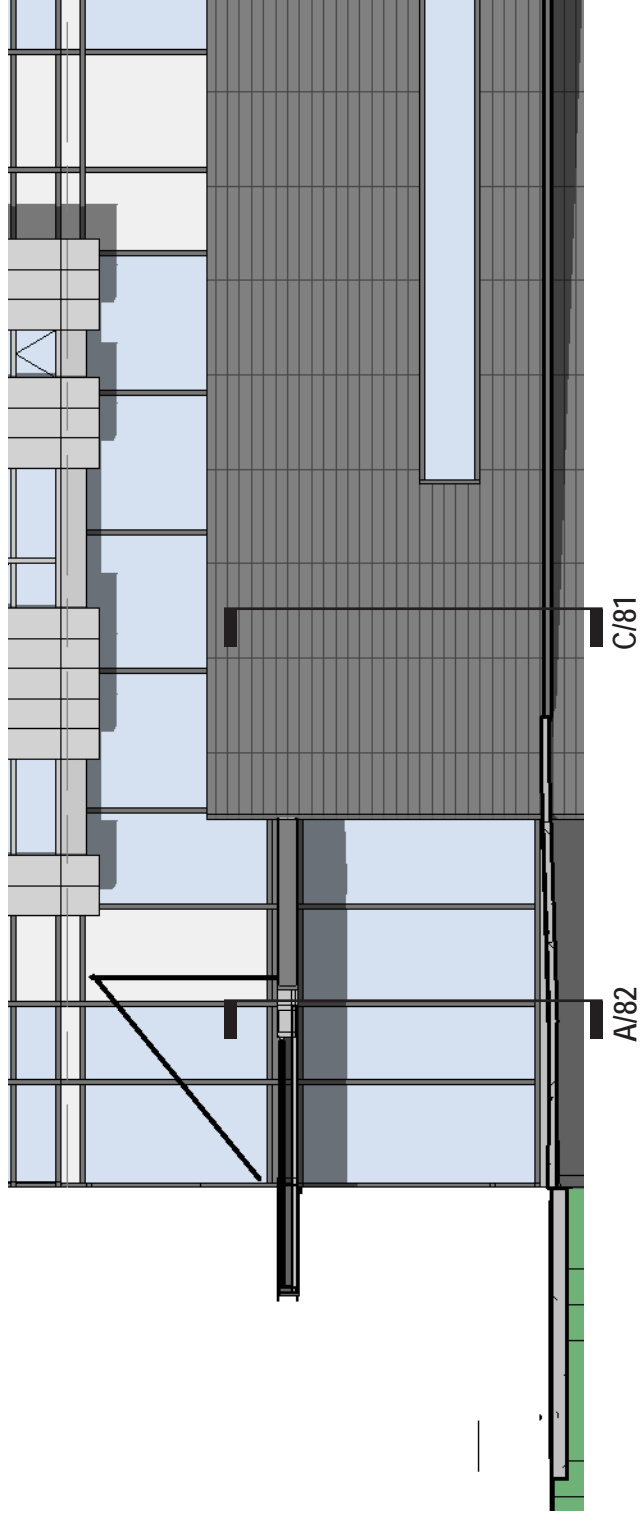

A Elevation at Residential Entry

C Section

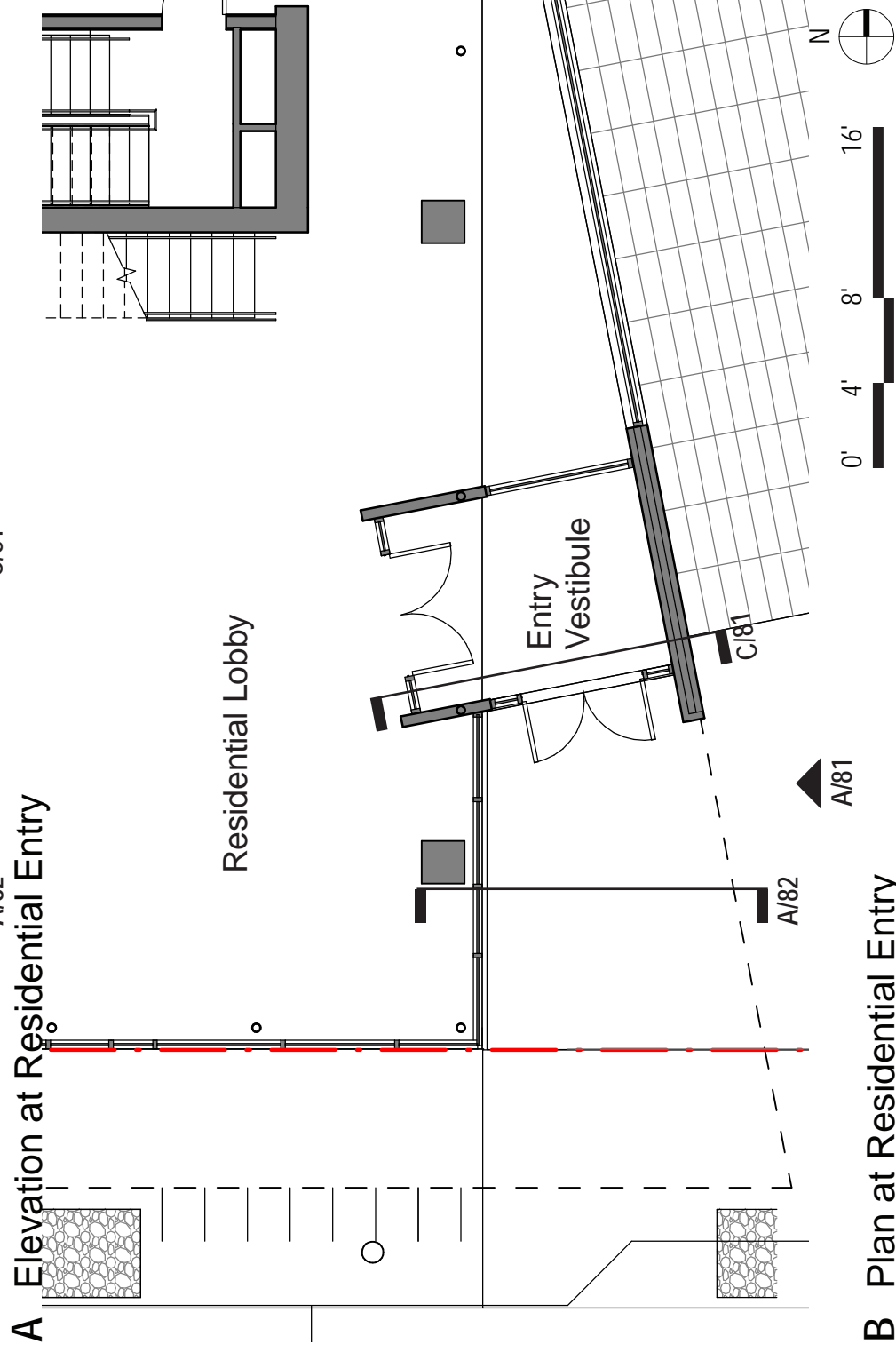
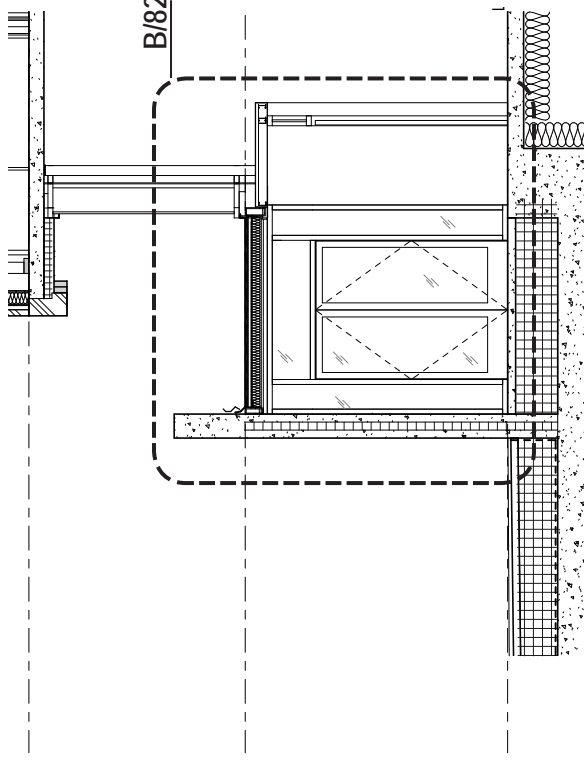

B Plan at Residential Entry



# 12th Avenue Building Details

## Residential Entry Details

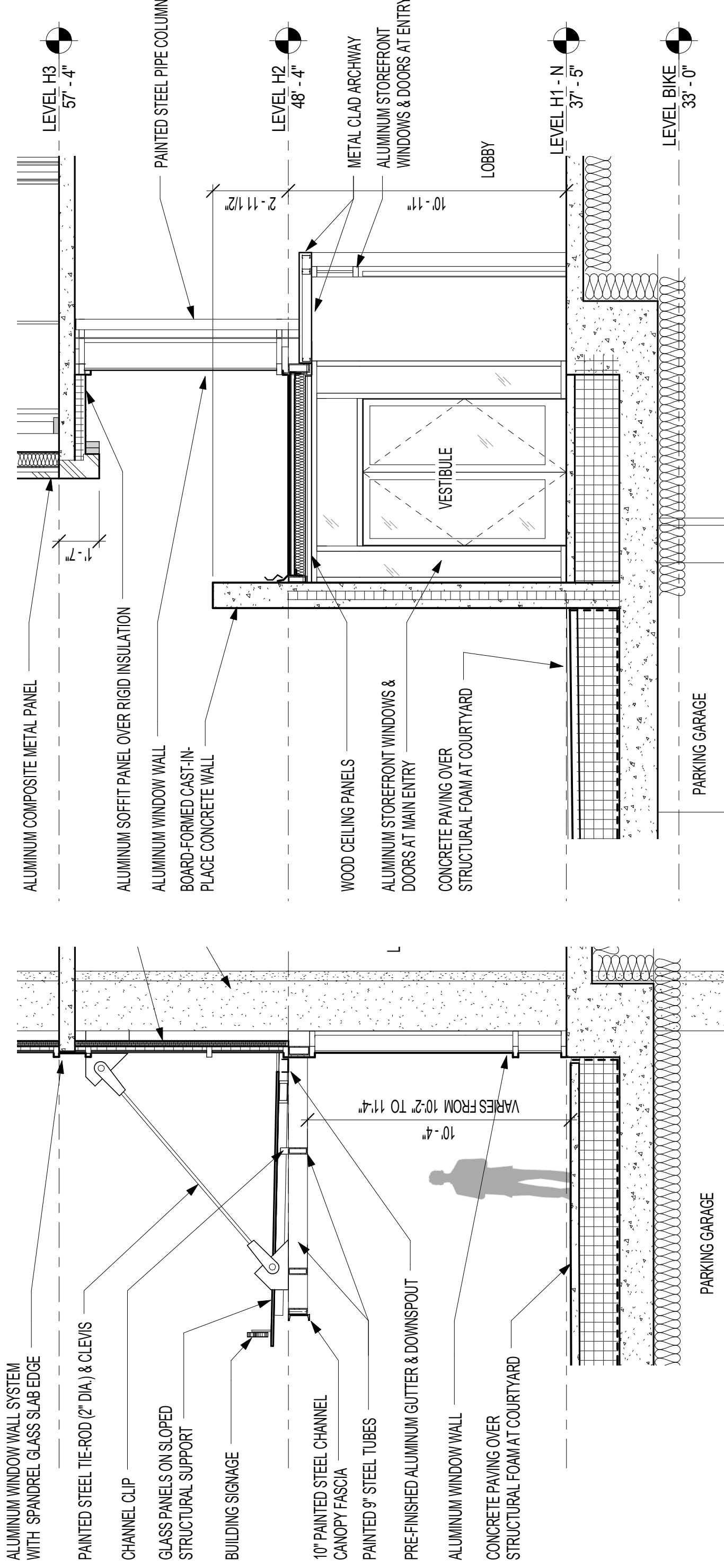

A Section at Lobby Canopy

B Section at Residential Vestibule

# 12th Avenue Building Details

## Residential Entry

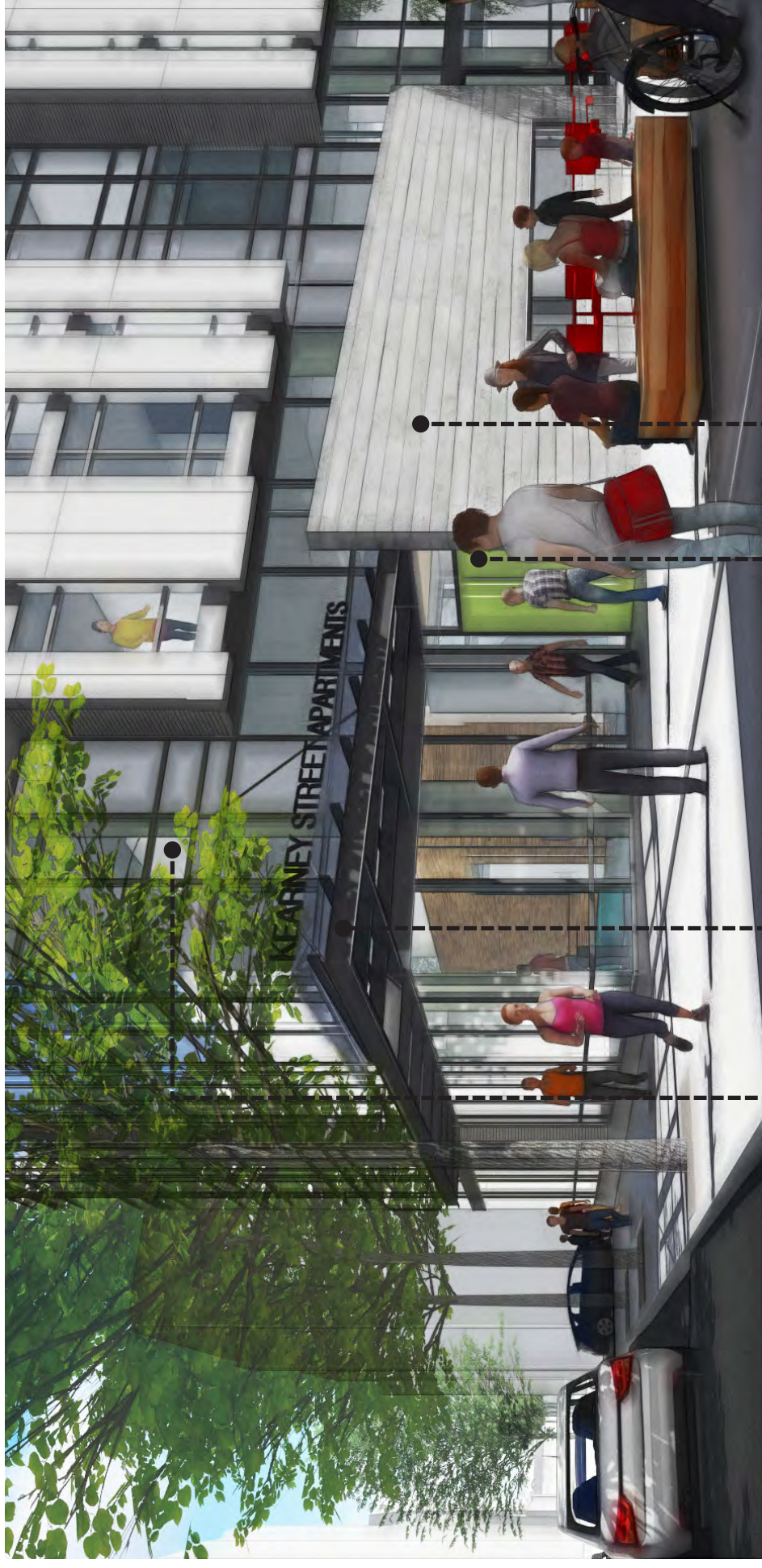

Rendering At Residential Entry



Window Wall

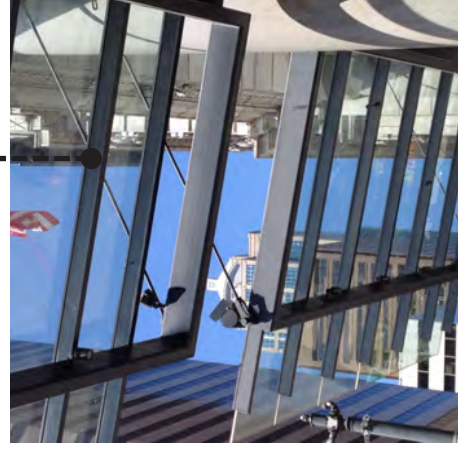

Painted Steel, Charcoal



Custom Colored Door



Board-Formed Concrete



Rendering At NE Corner

# 12th Avenue Building Details

Building Facade Elements

# 12th Avenue Building Details

## Building Facade Elements Diagram

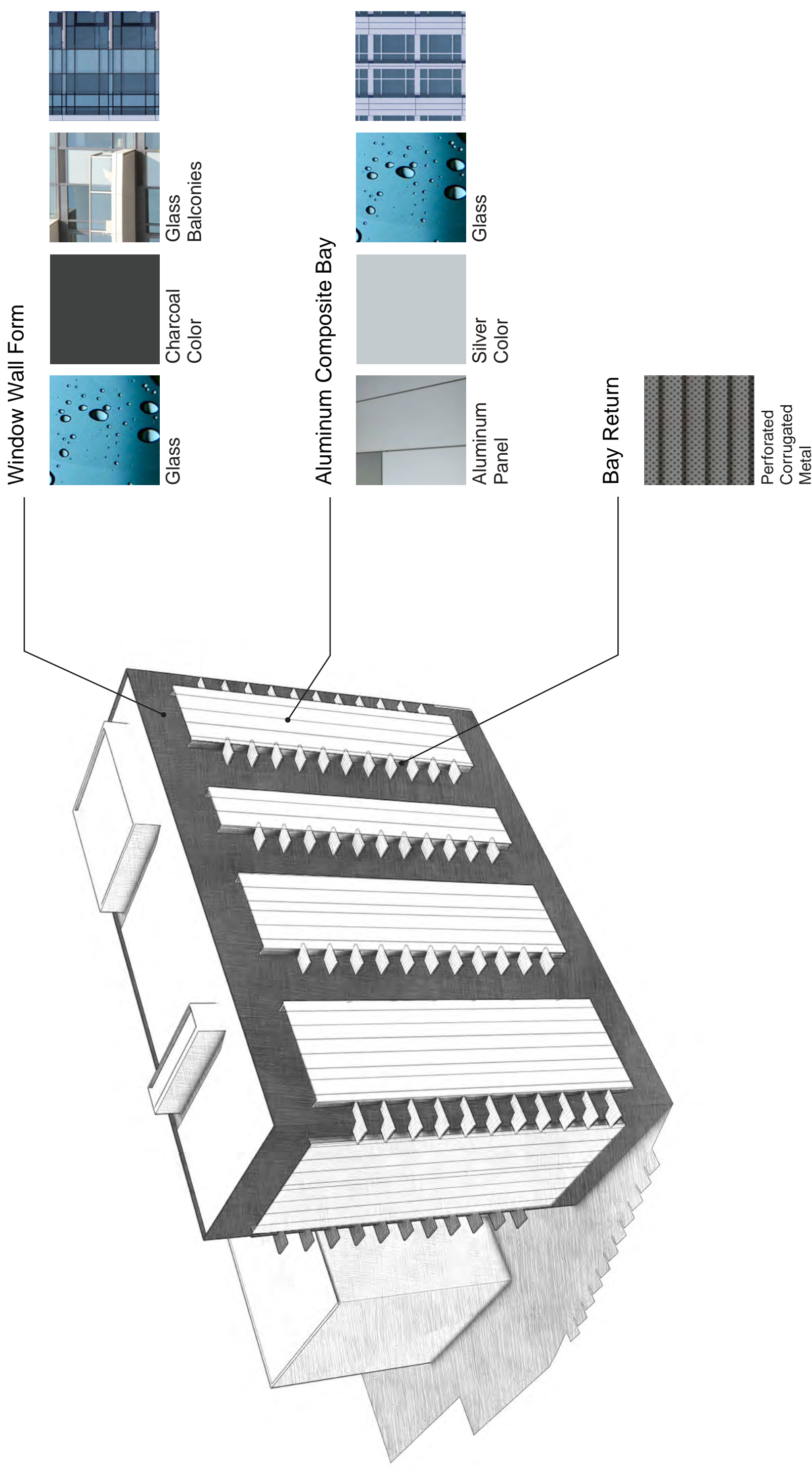

# 12th Avenue Building Details

## Typical Facade Elements - Window Wall Form

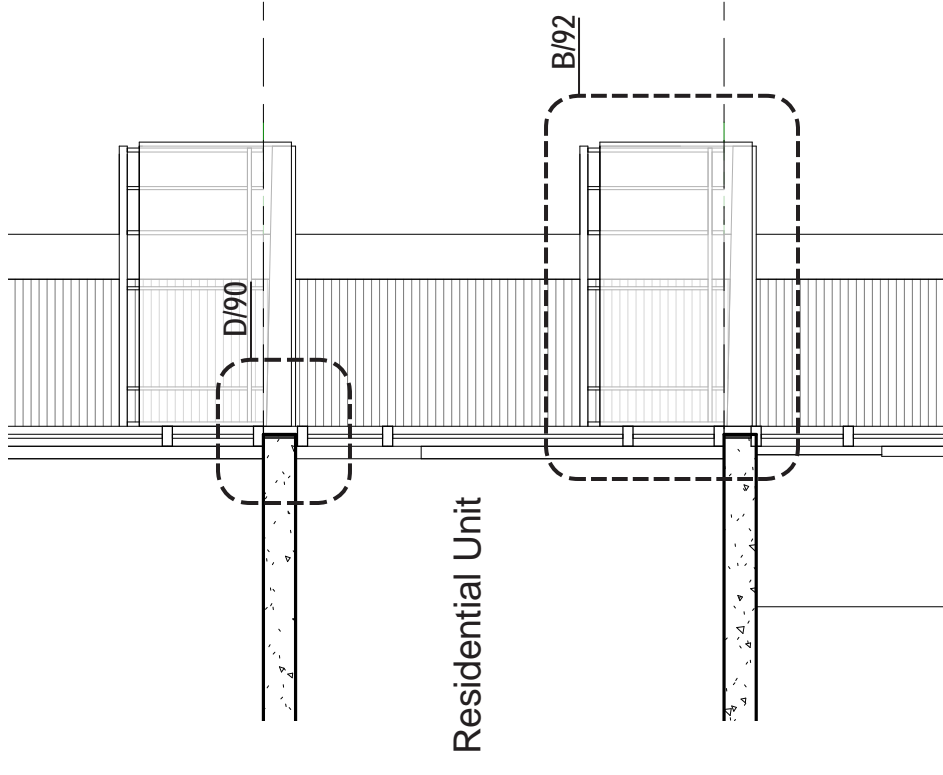
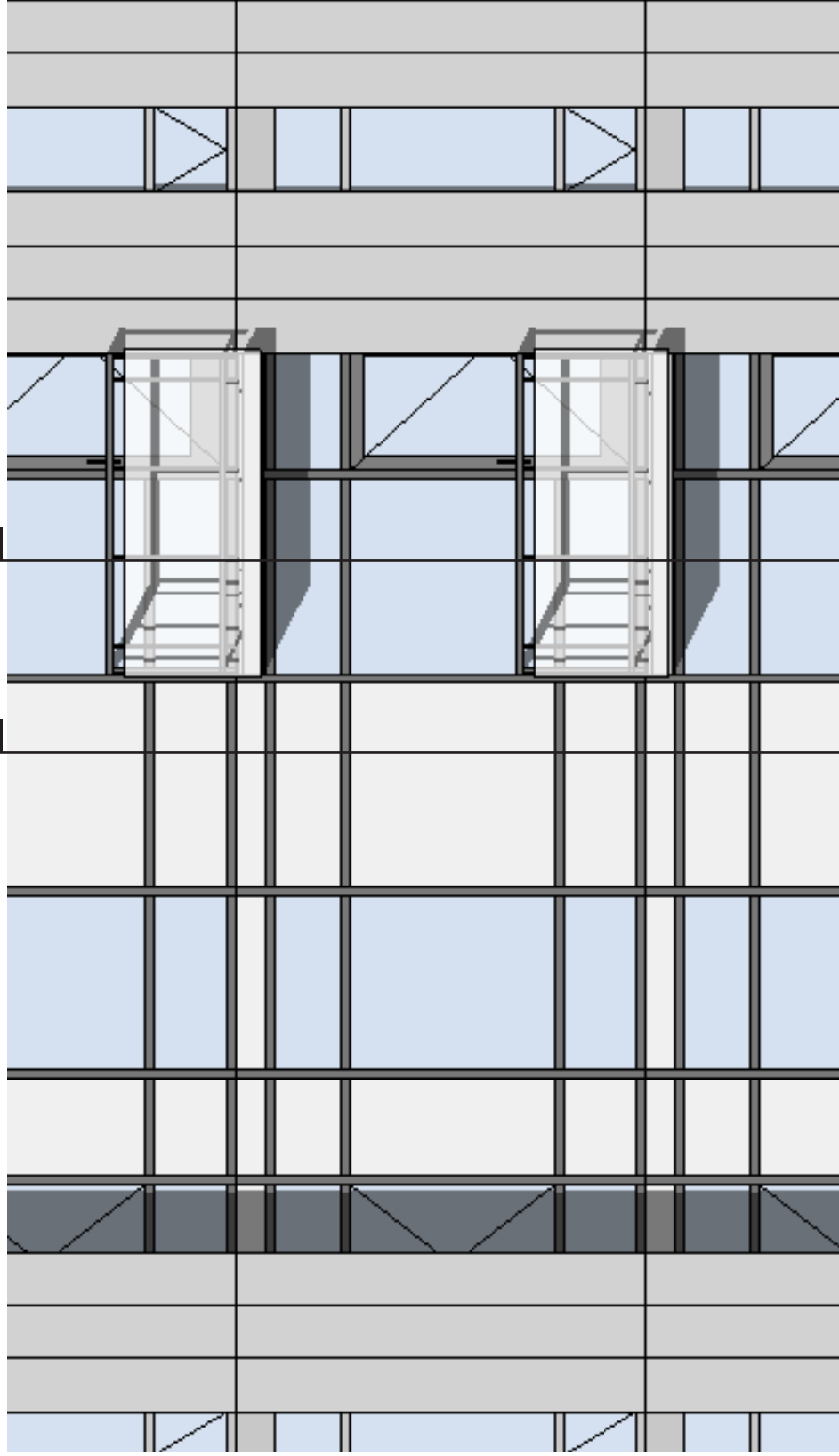

A Enlarged Elevation

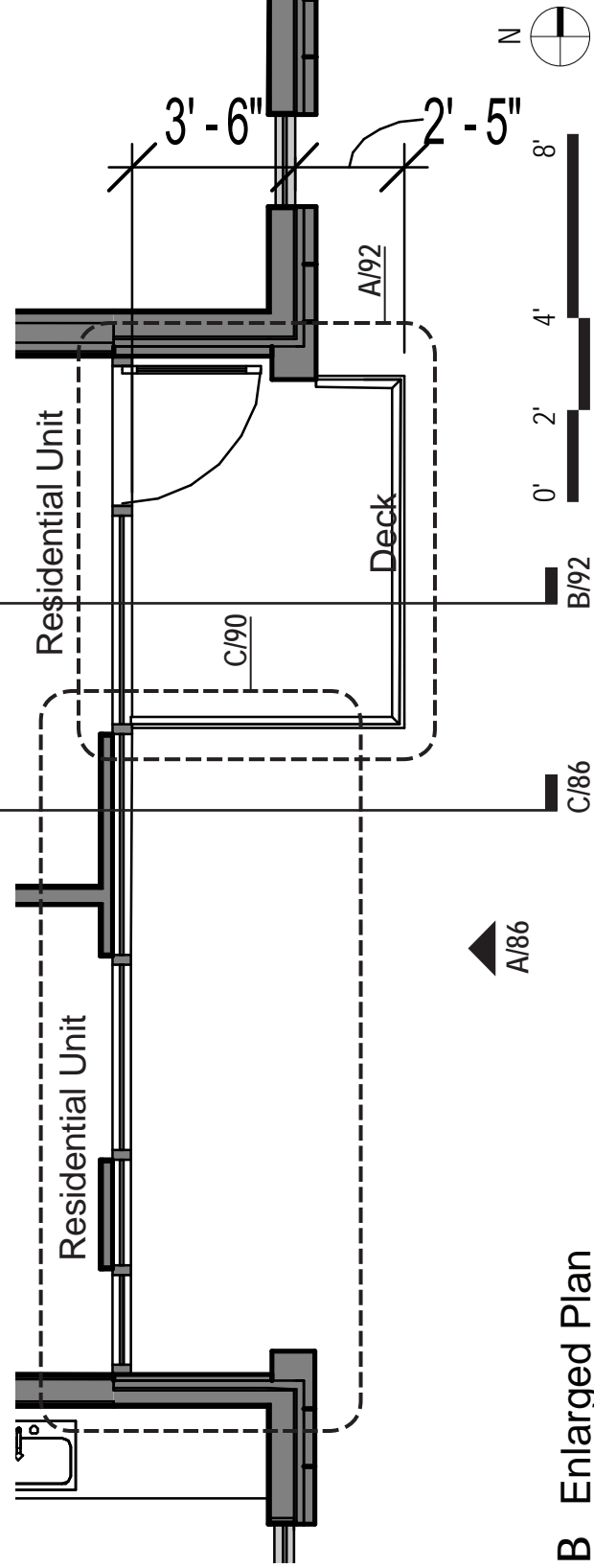

B Enlarged Plan

C Section



# 12th Avenue Building Details

## Typical Facade Elements - Bays

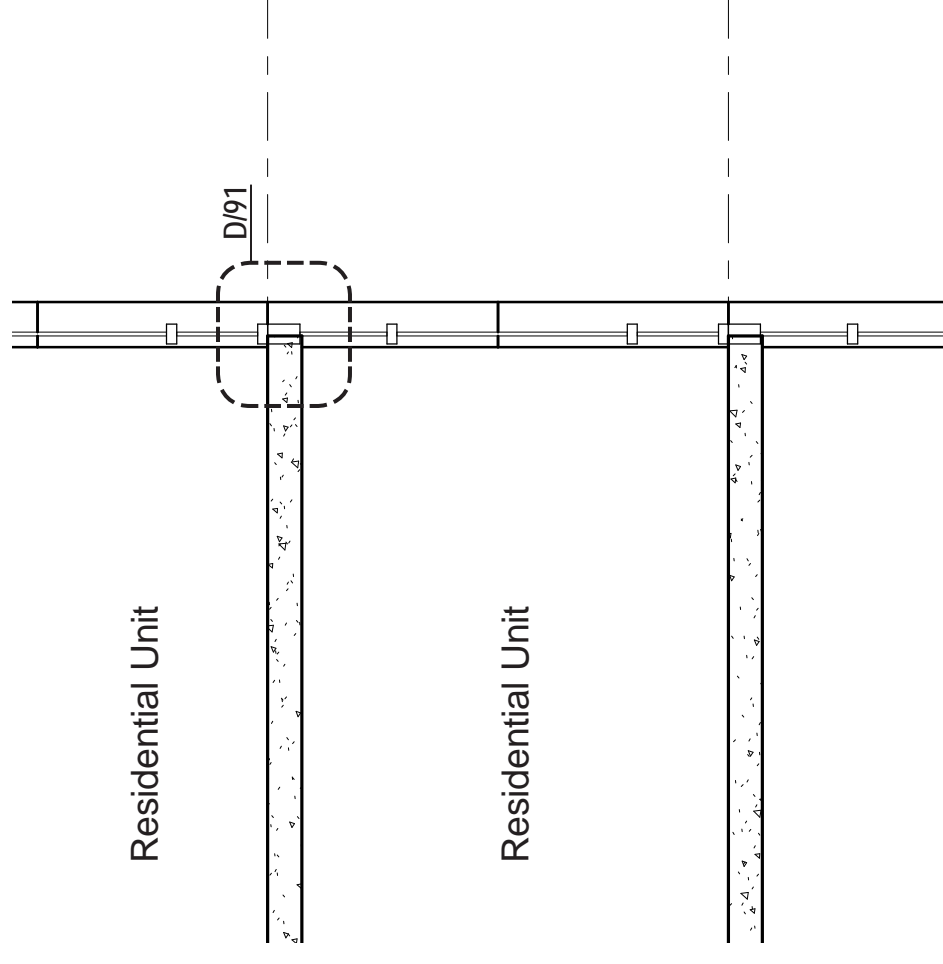
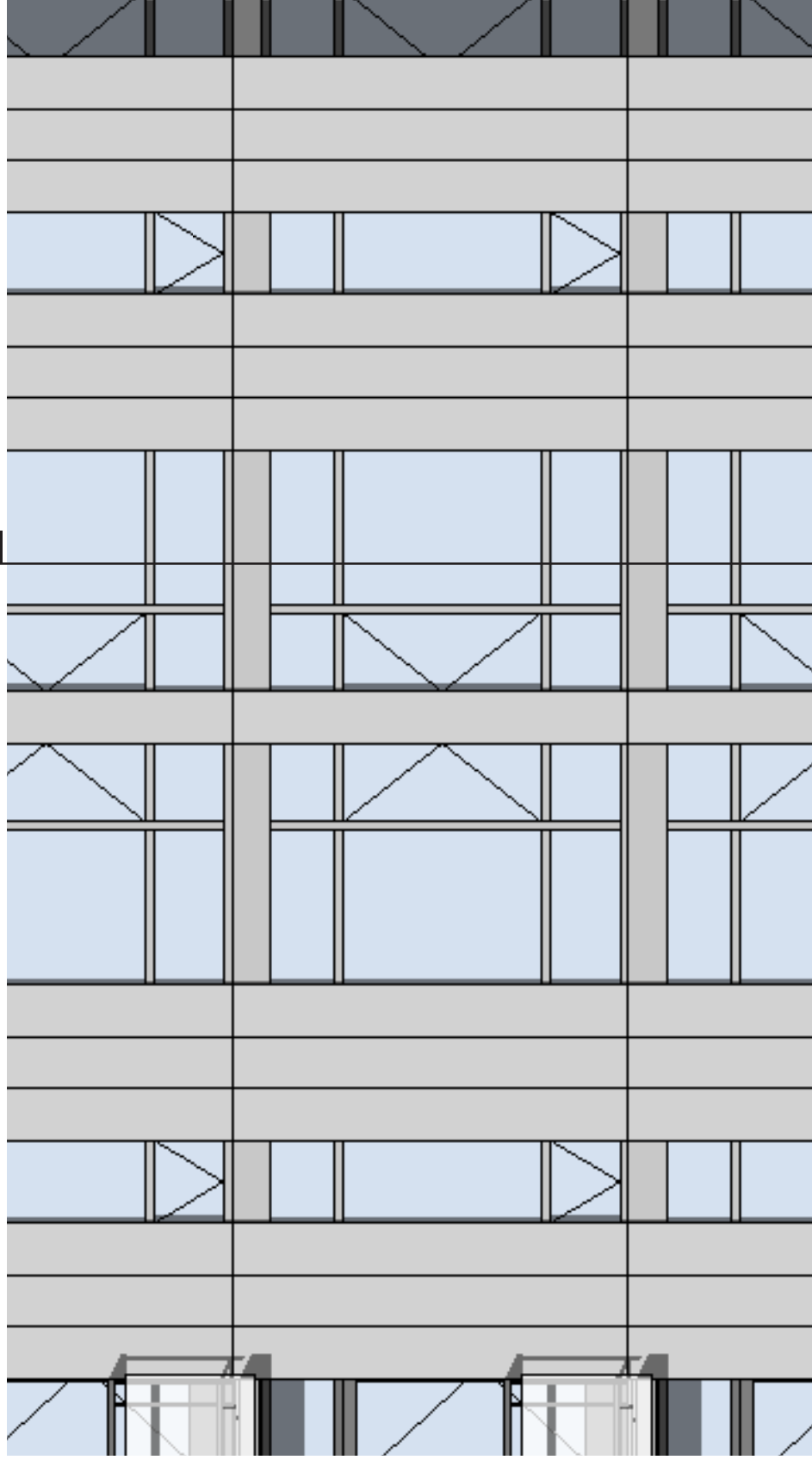

A Enlarged Elevation

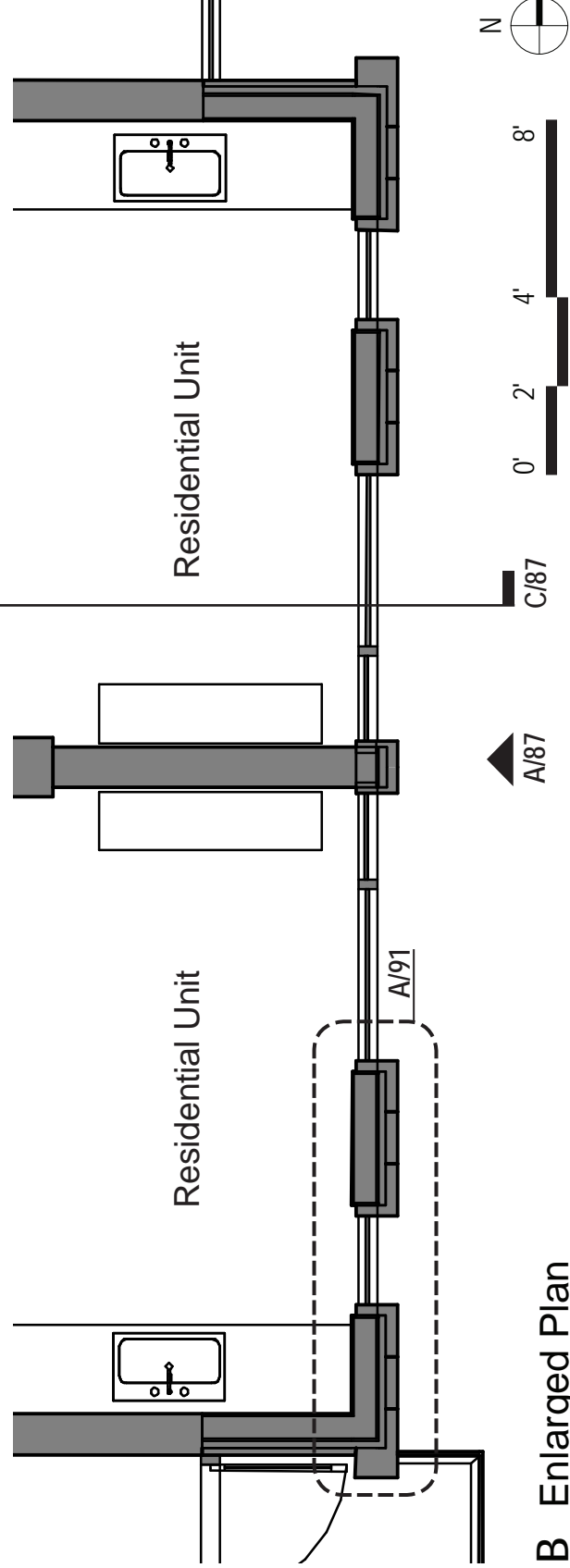

B Enlarged Plan

C Section



# 12th Avenue Building Details

## Typical Facade Elements - Window Wall Form

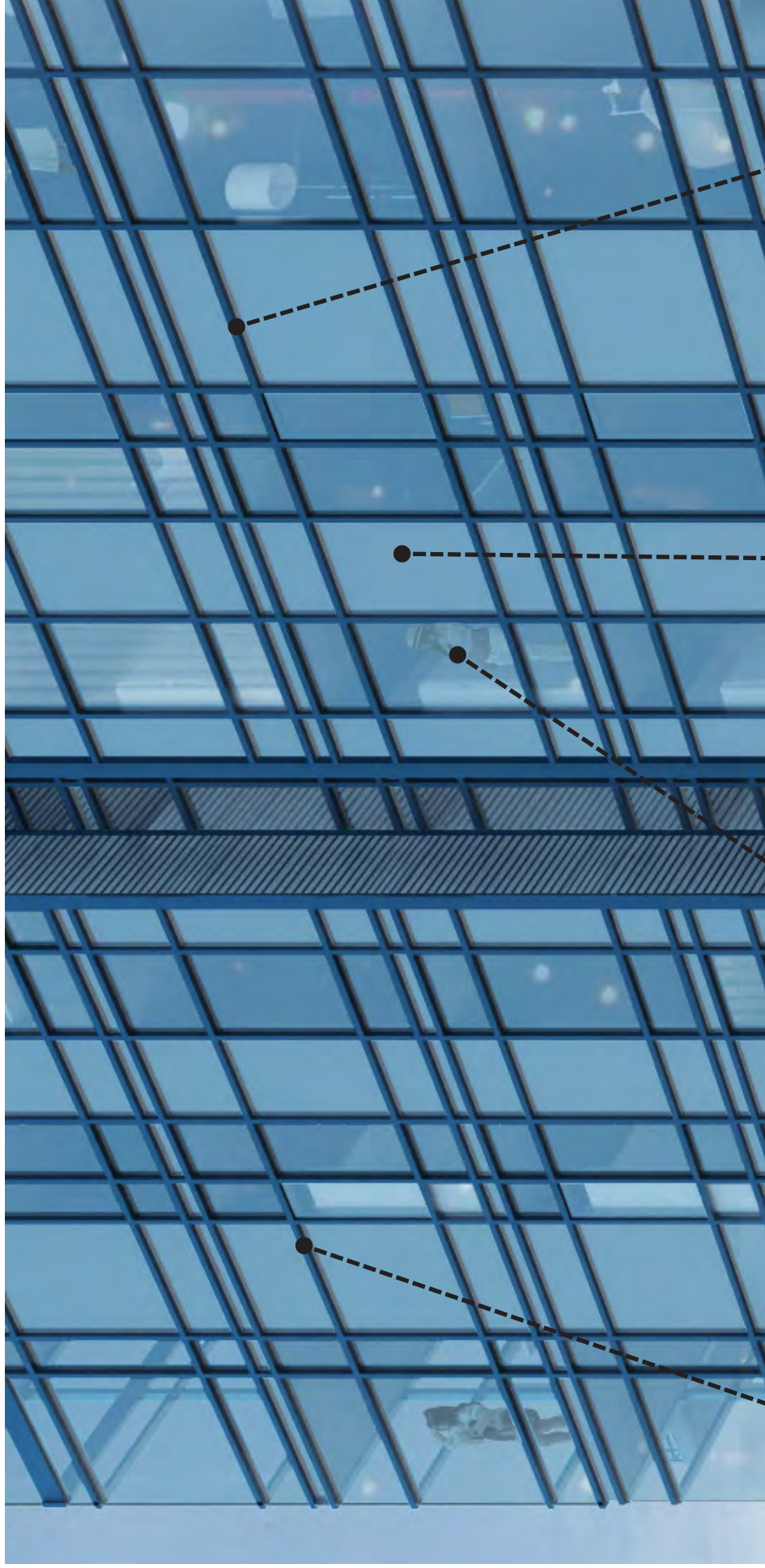

Rendered Perspective

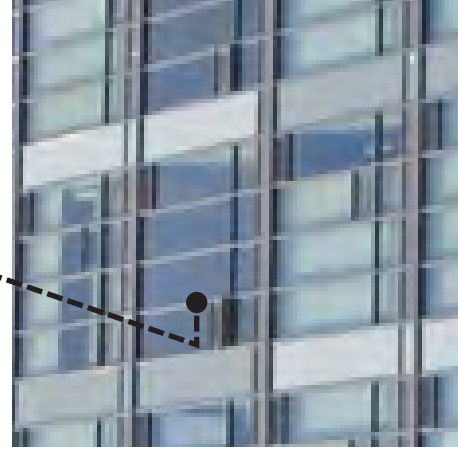

Window Wall

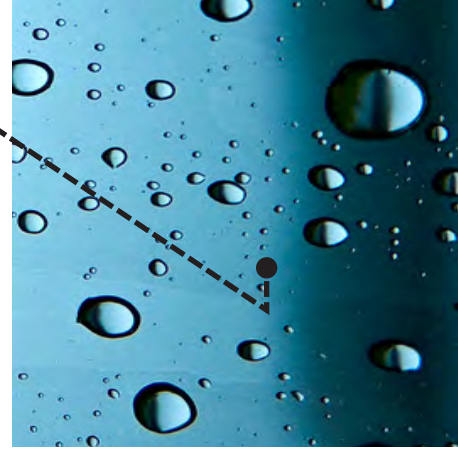

Vision Glass

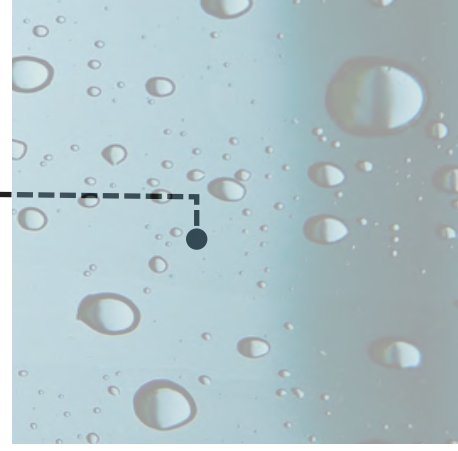

Spandrel Glass

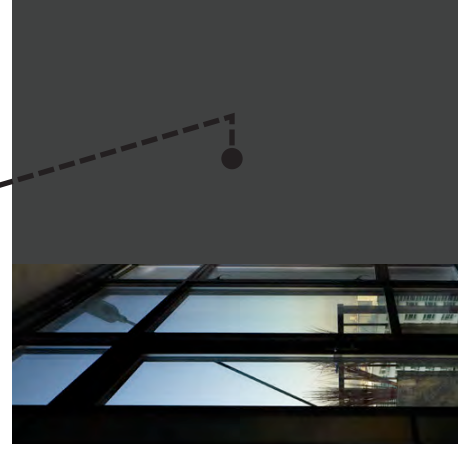

Mullion Color

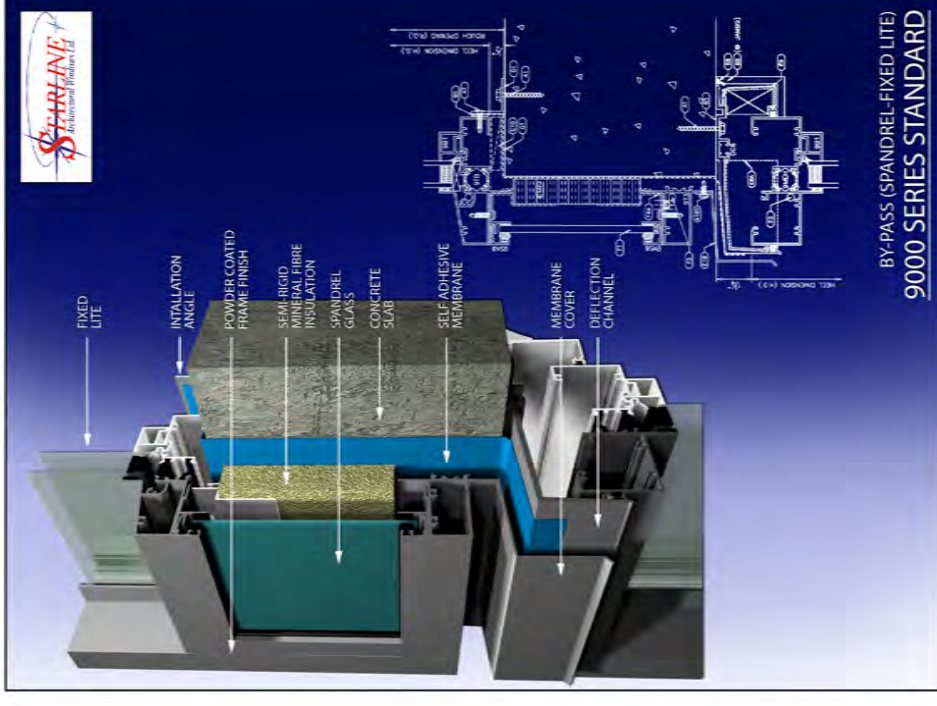

Window Wall Slab Bypass Detail

BY-PASS (SPANDREL-FIXED LITE)  
9000 SERIES STANDARD



FIXED LITE  
INSTALLATION ANGLE  
POWDER COATED FRAME FINISH  
SEMI-RIGID MINERAL FIBRE INSULATION  
SPANDREL GLASS  
CONCRETE SLAB  
SELF ADHESIVE MEMBRANE  
MEMBRANE COVER  
DEFLECTION CHANNEL

# 12th Avenue Building Details

## Typical Facade Elements - Bays



Rendered Perspective



Aluminum Composite Panel

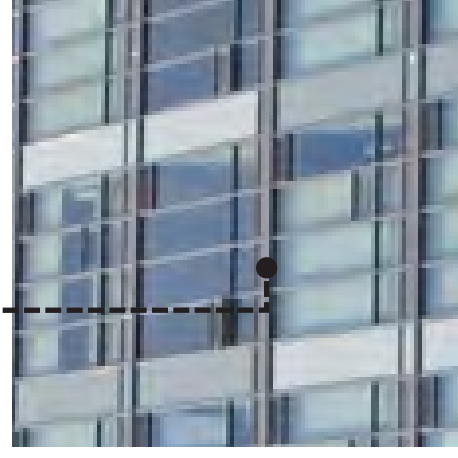

Window Wall

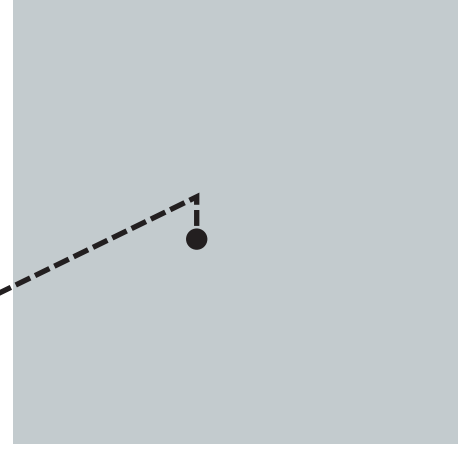

Mullion Color

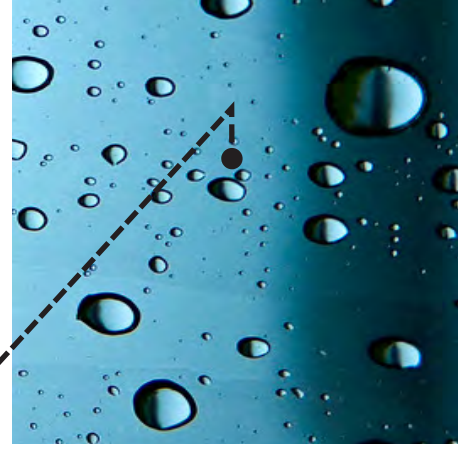

Vision Glass

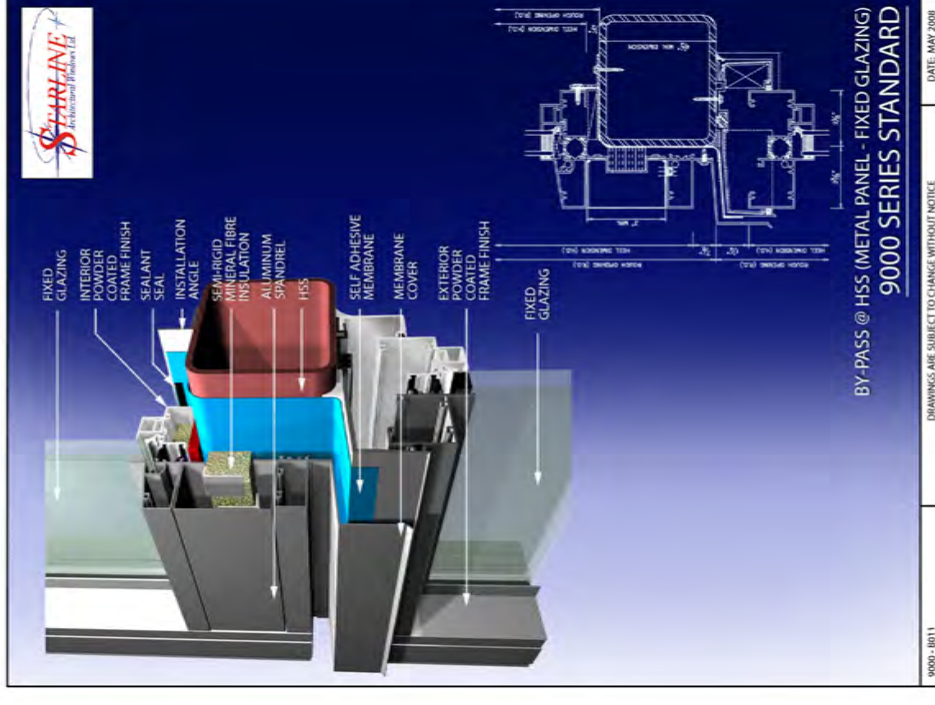

Window Wall Slab Bypass Detail

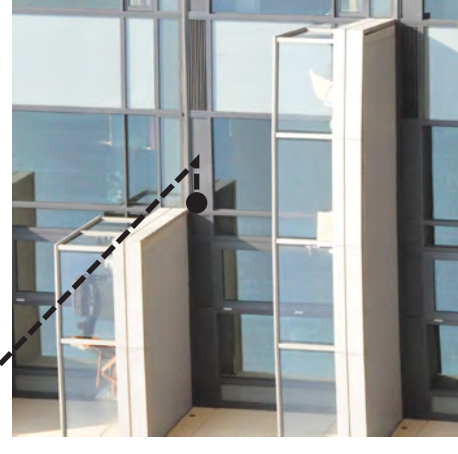

Prefinished Alum Balcony Railings with Vision Glass



# 12th Avenue Building Details

Typical Facade Elements - Window Wall Form / Balconies

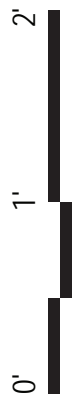
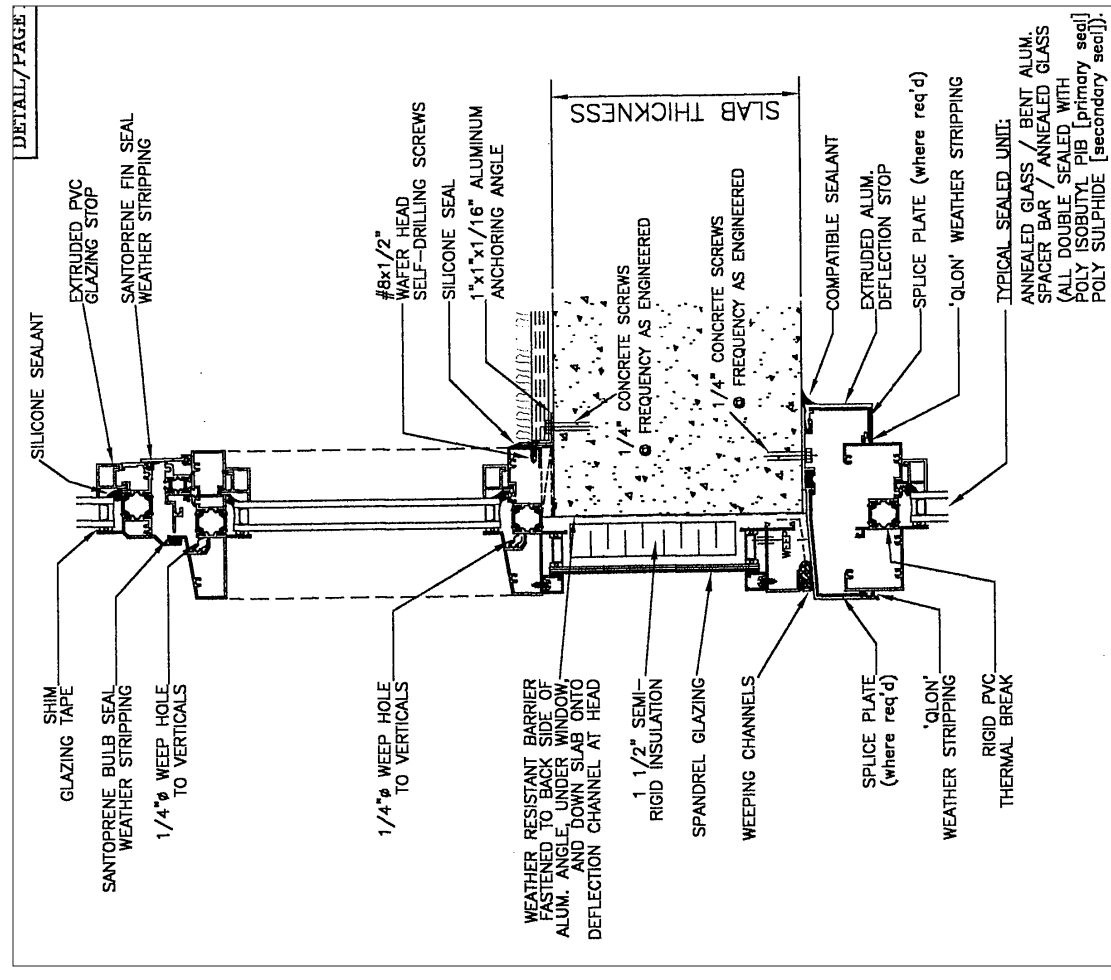
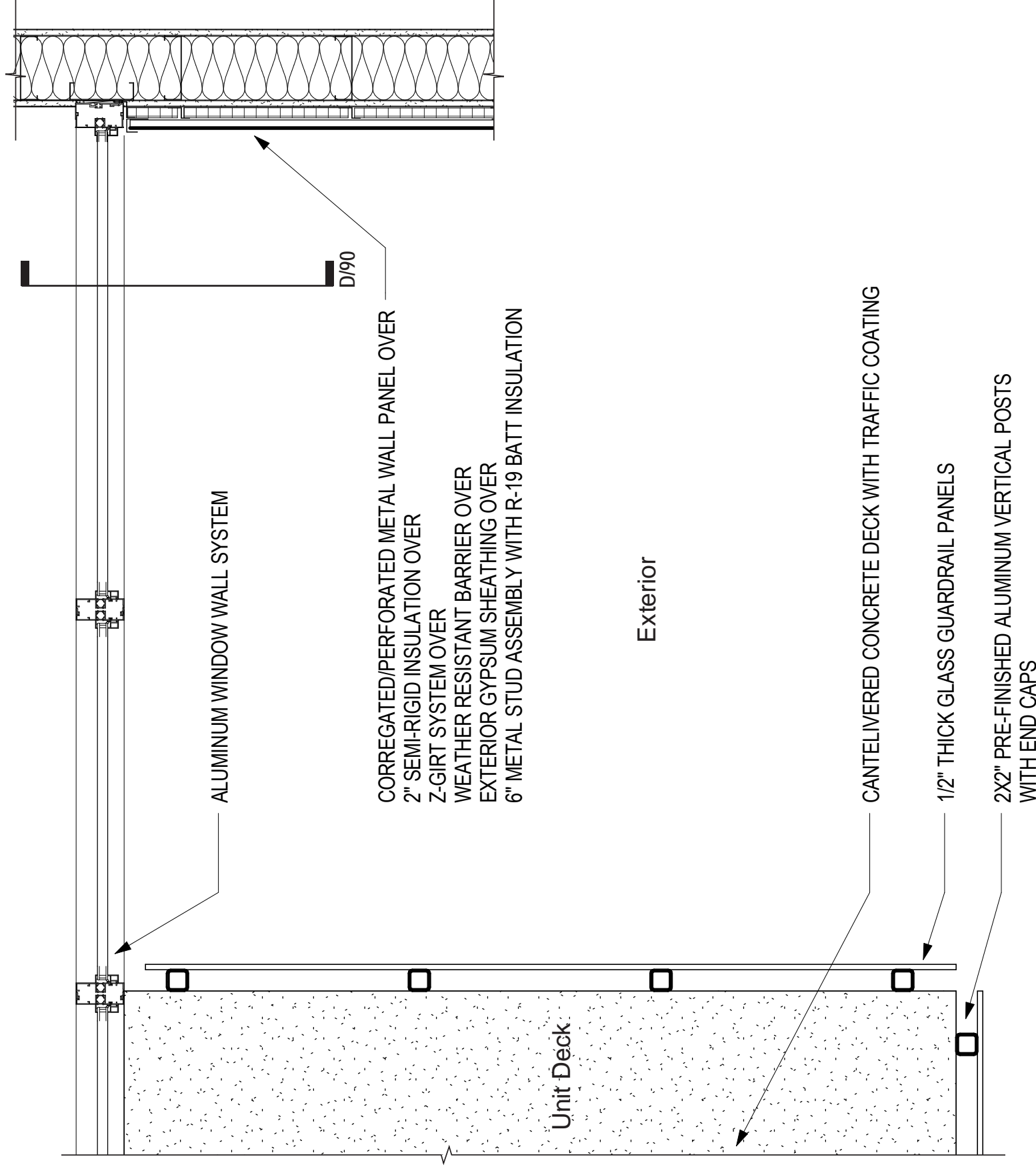

C Detail at Window Wall Form

D Spandrel Slab Edge Detail (Starline)

# 12th Avenue Building Details

Typical Facade Elements - Bays with Aluminum Composite Panels

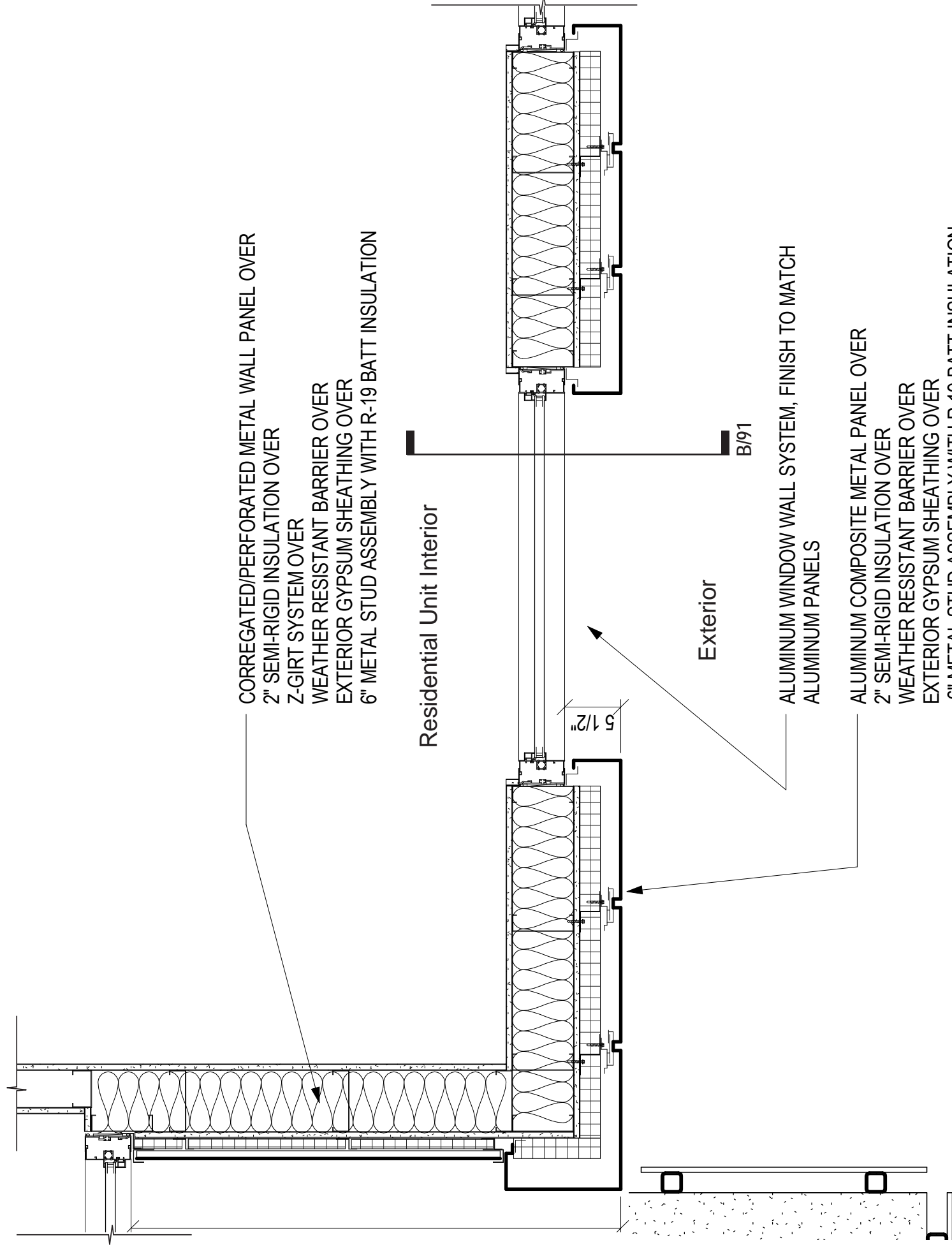

A Detail at Aluminum Composite Panels

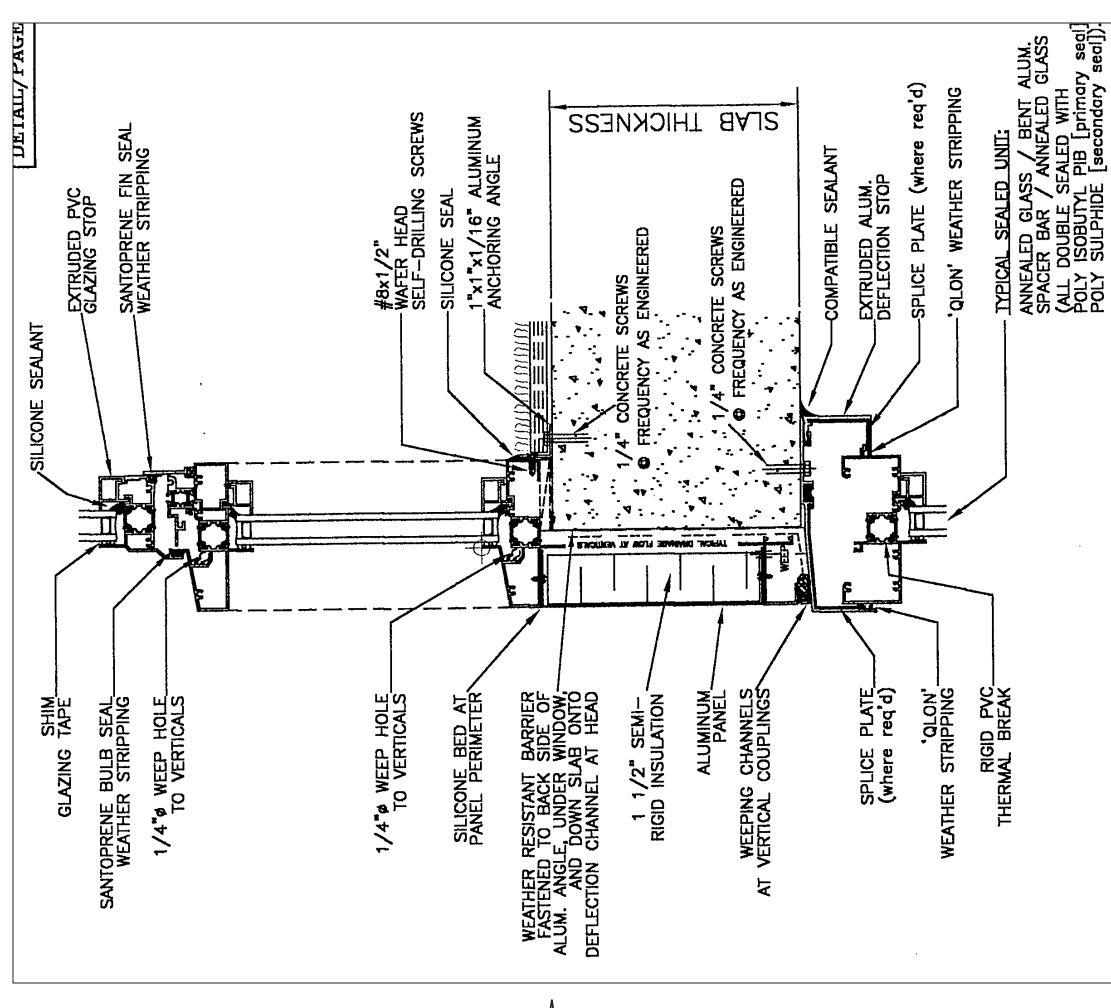

B Aluminum Panel Slab Edge Detail (Starline)



# 12th Avenue Building Details

Typical Facade Elements - Balconies at Window Wall Form

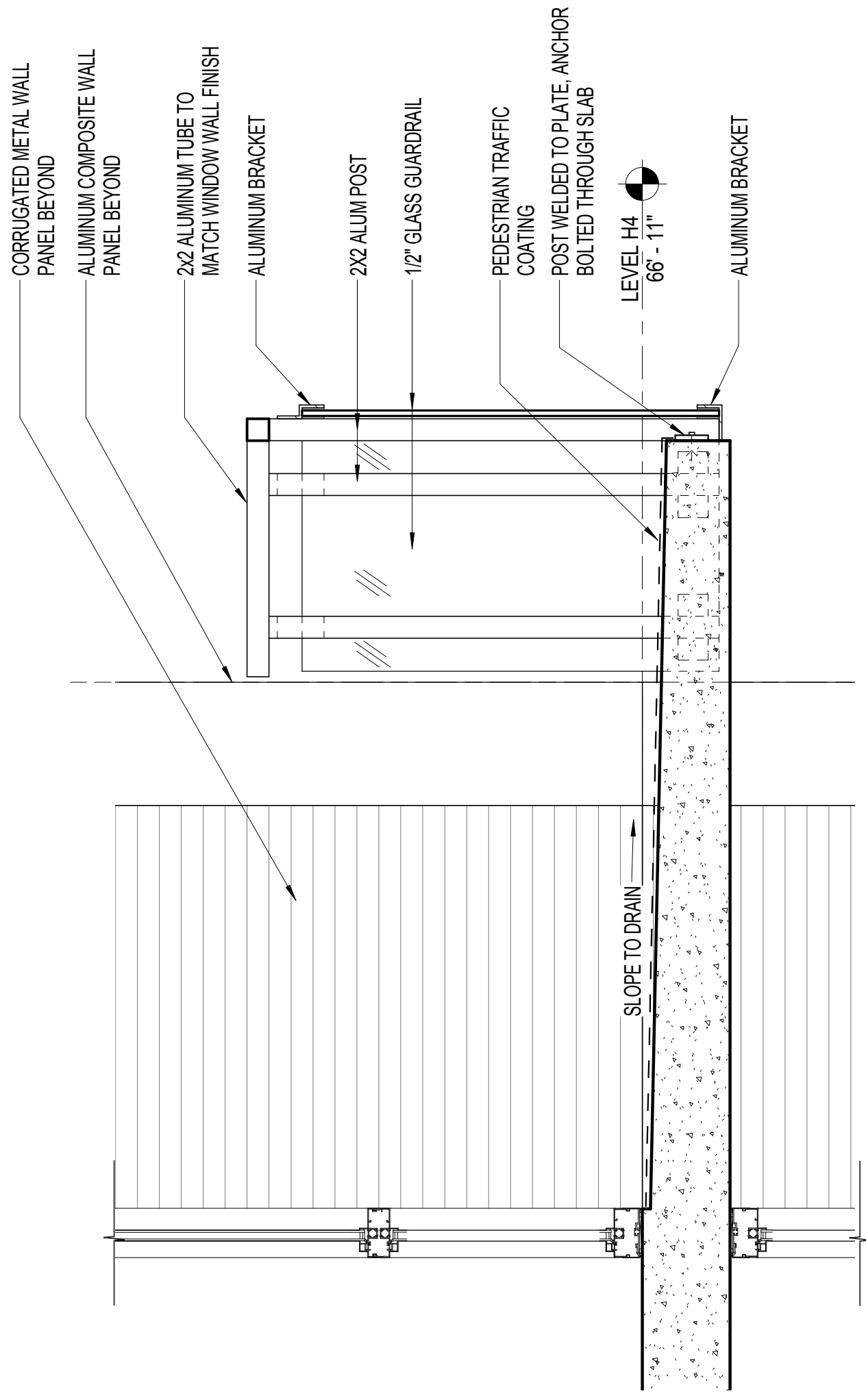

B Section

# 12th Avenue Building Details

Bay Termination at Penthouse Level

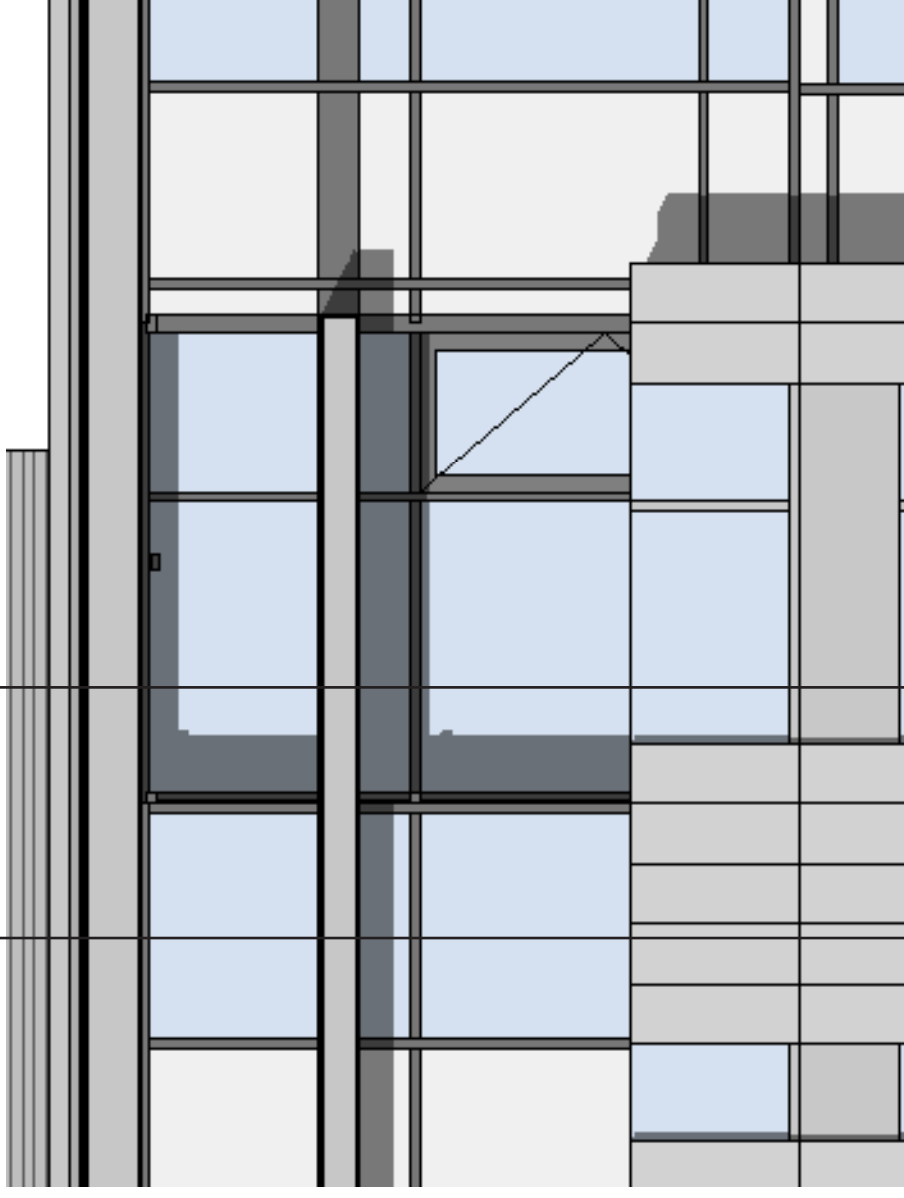

A Enlarged Elevation

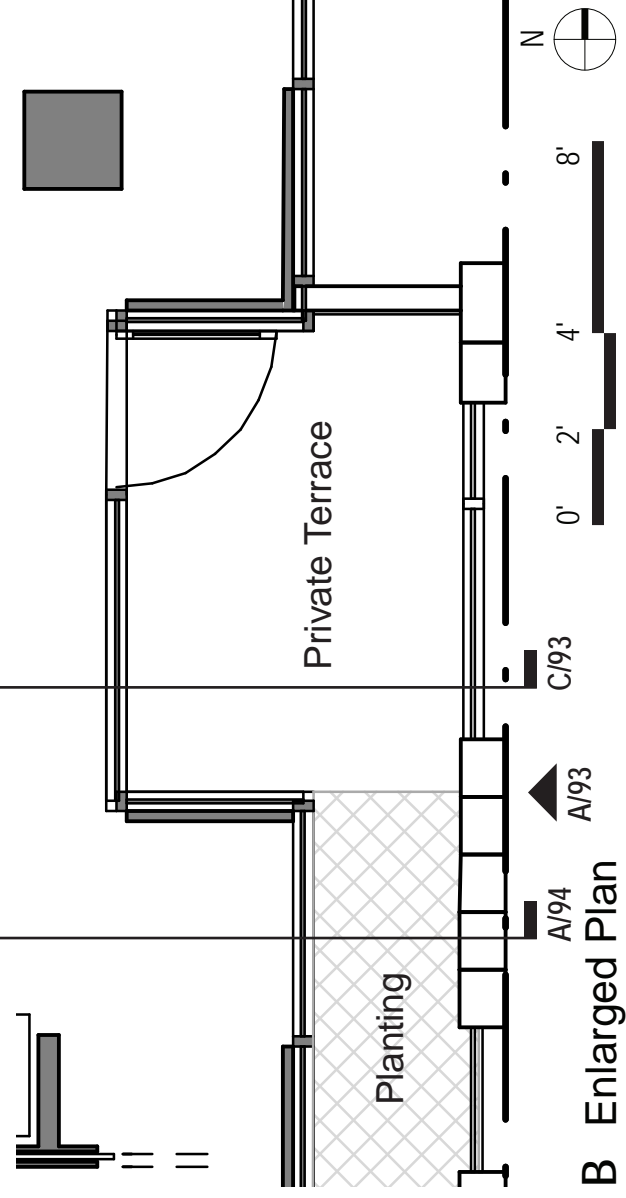

B Enlarged Plan

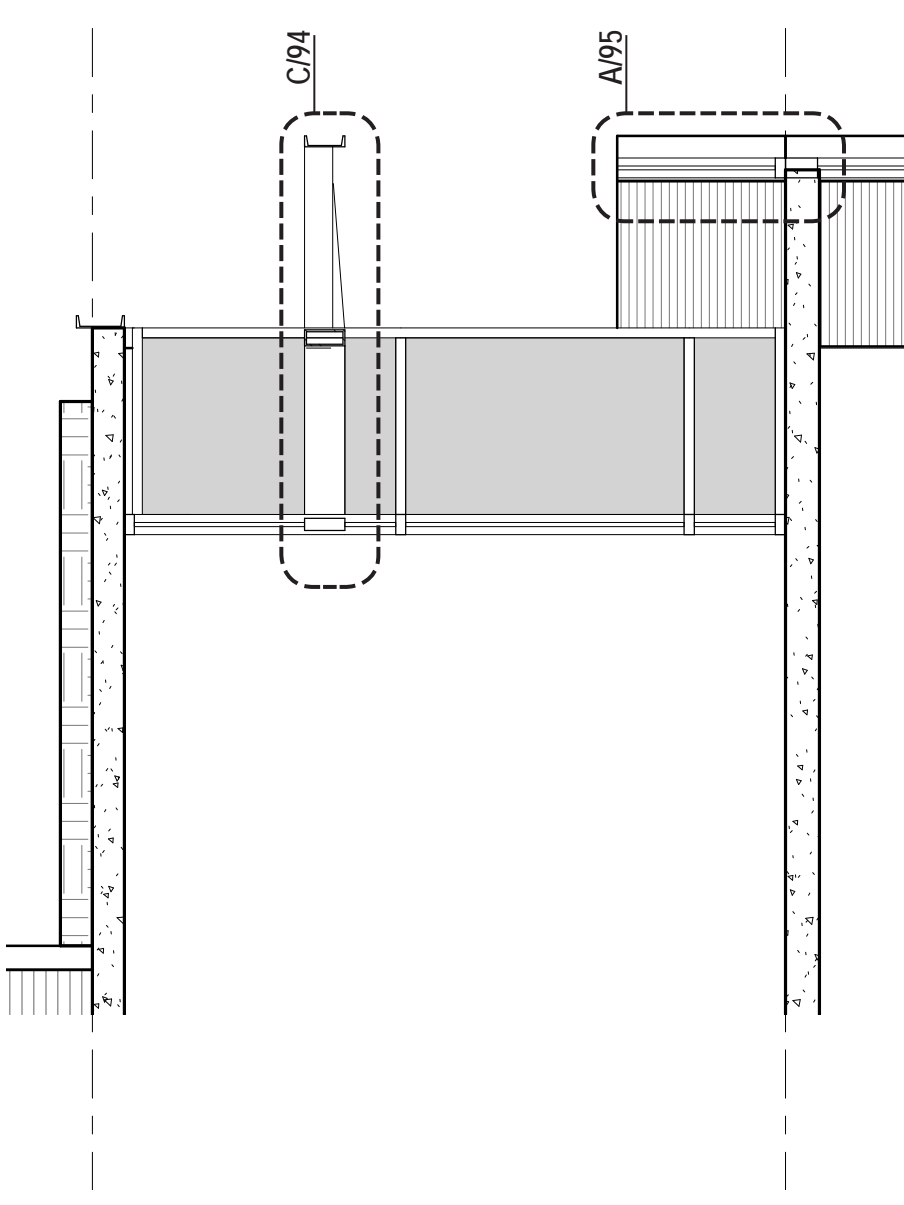

C Section



# 12th Avenue Building Details

Bay Termination at Penthouse Level

ALUMINUM & GLASS GUARDRAIL, TYP.

ECO-ROOF

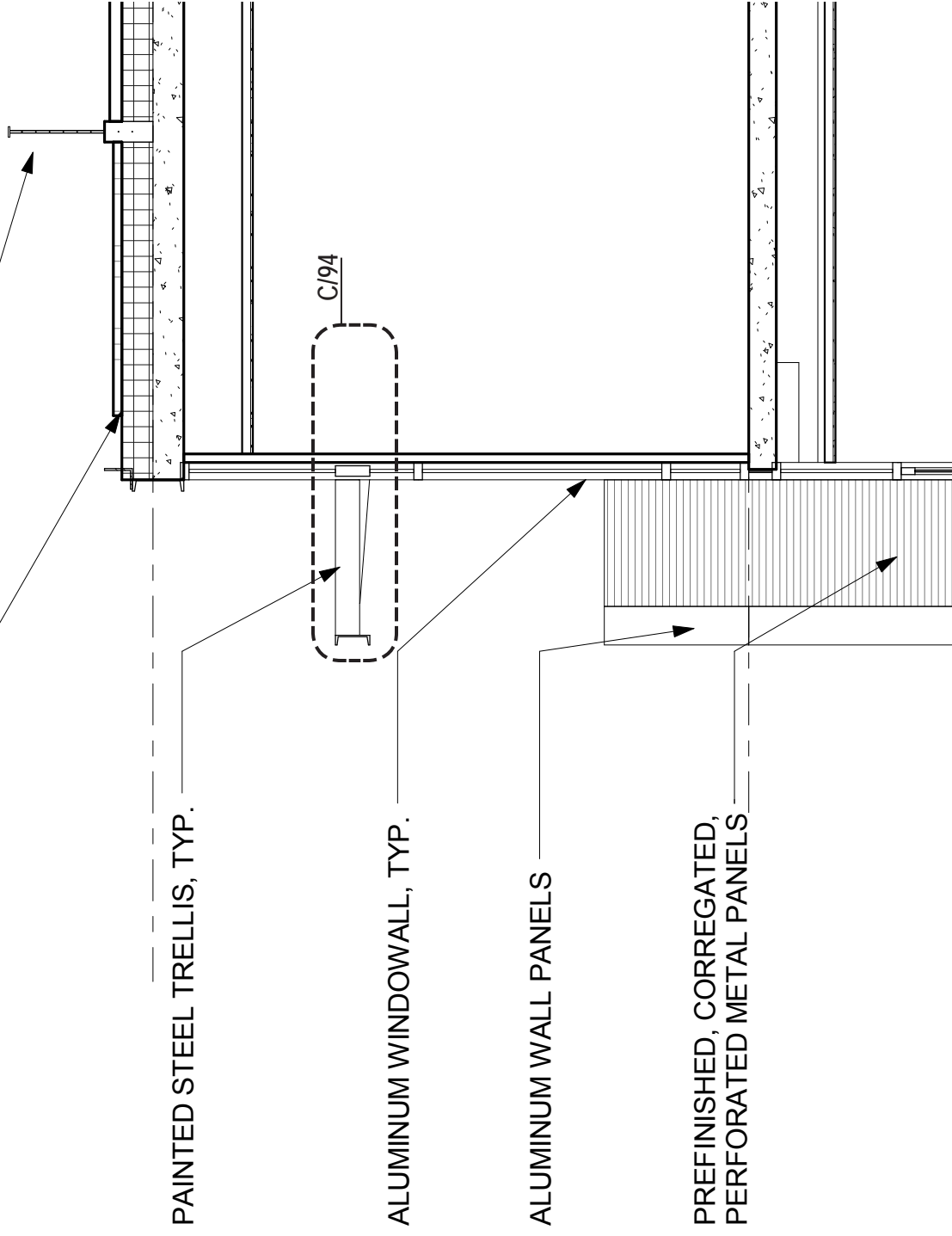

A Detail Section at Penthouse

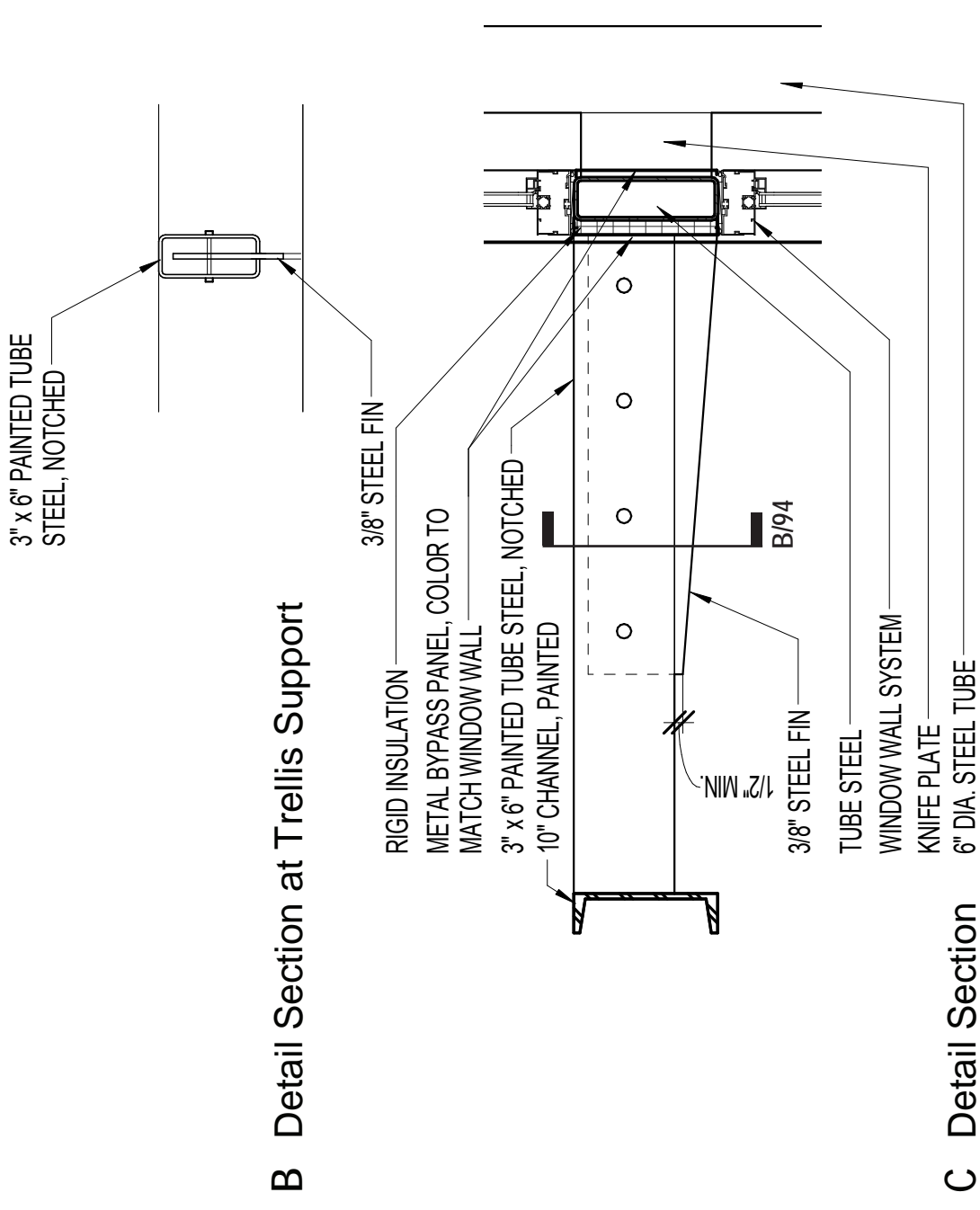

B Detail Section at Trellis Support

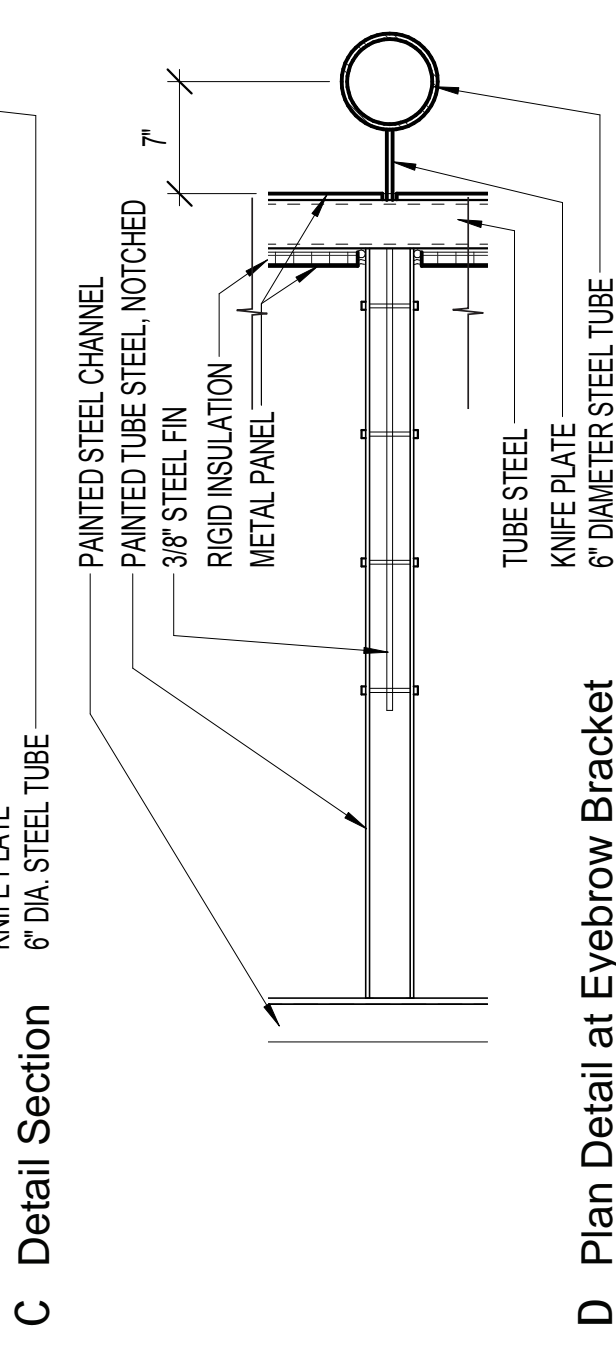

C Detail Section

D Plan Detail at Eyebrow Bracket

# 12th Avenue Building Details

Trellis and Inset Private Terrace Details

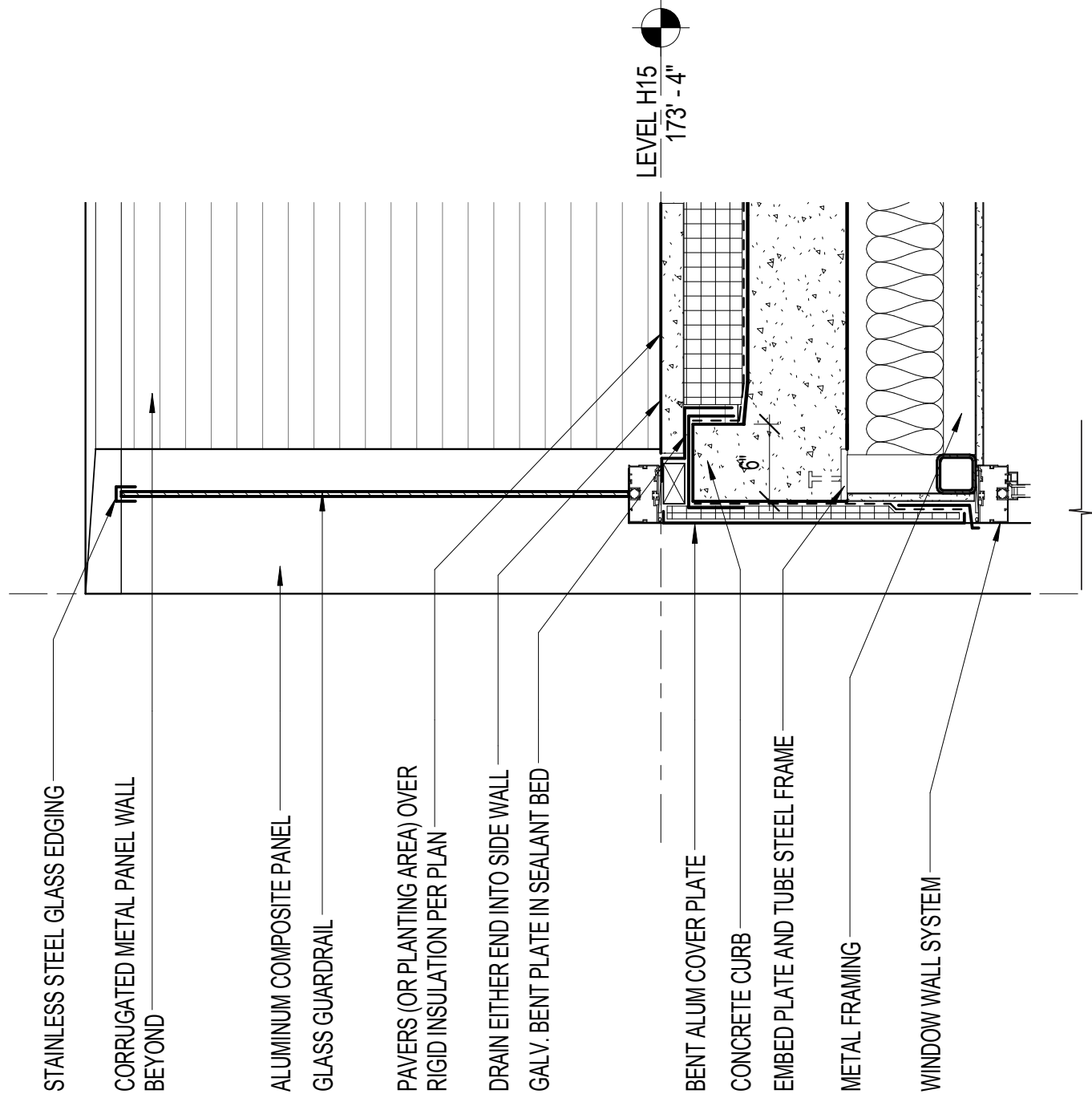

A Detail Section

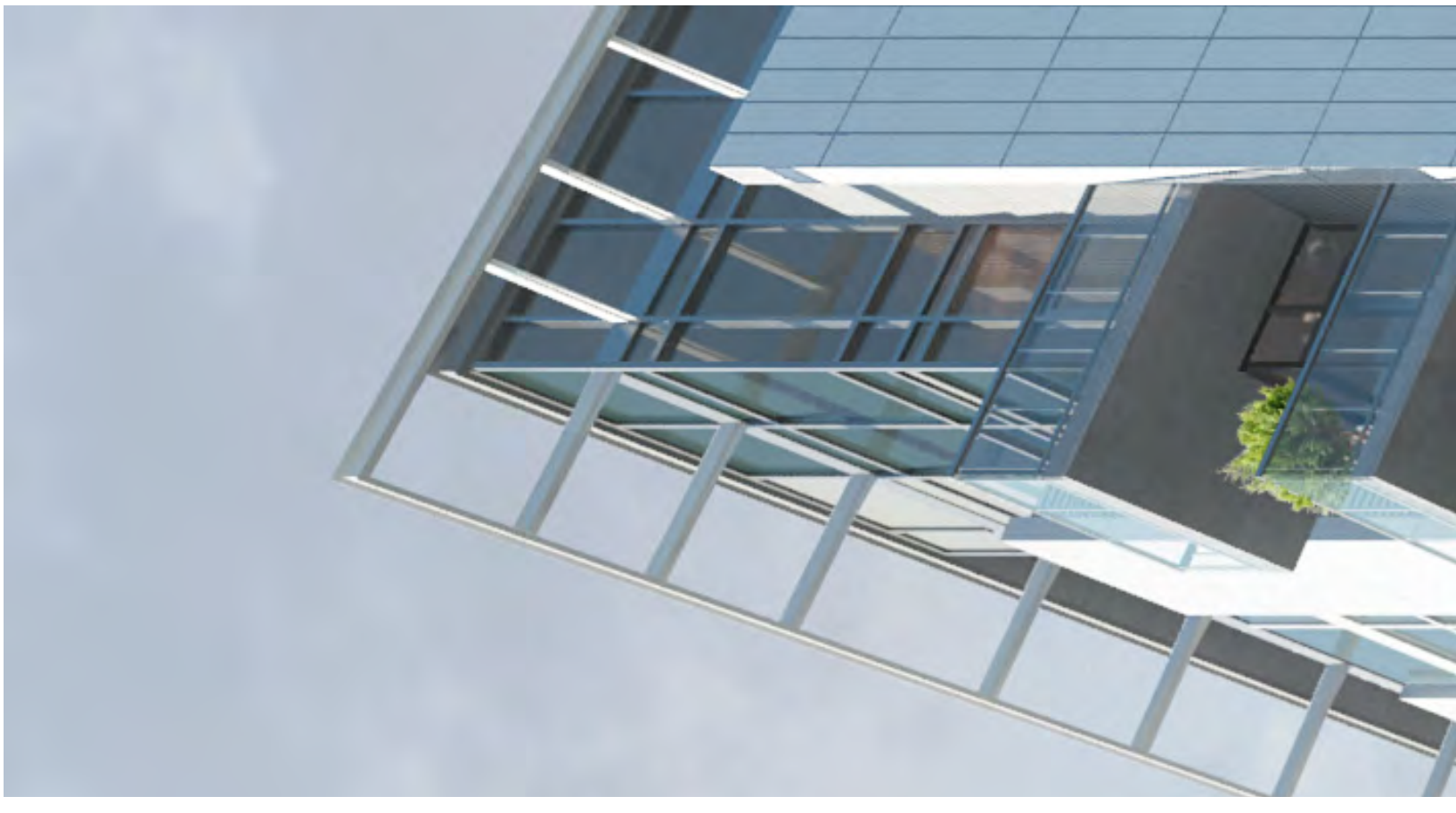

# 12th Avenue Building Details

Roof View from Southeast

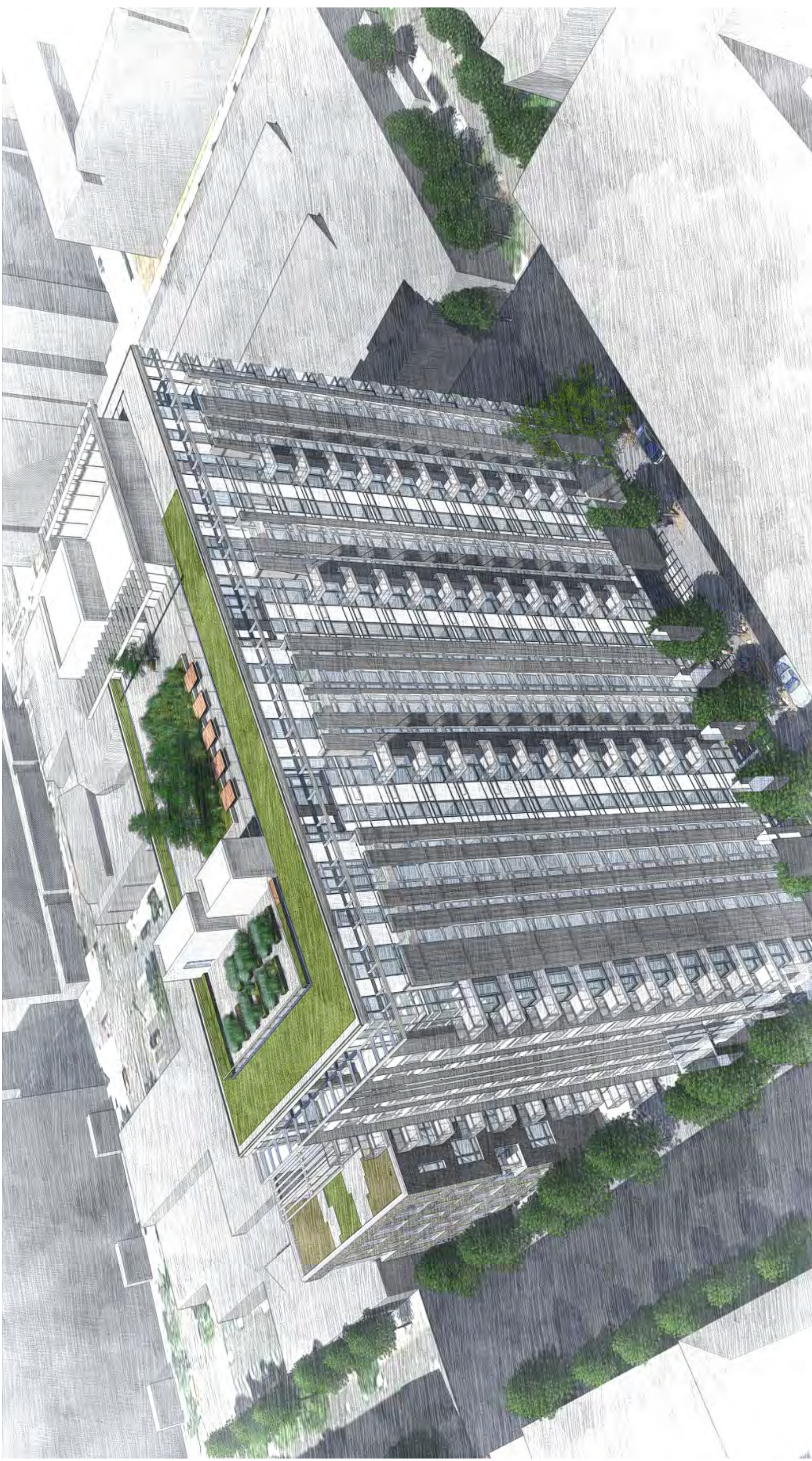

# 12th Avenue Building Details

## Mechanical Penthouses

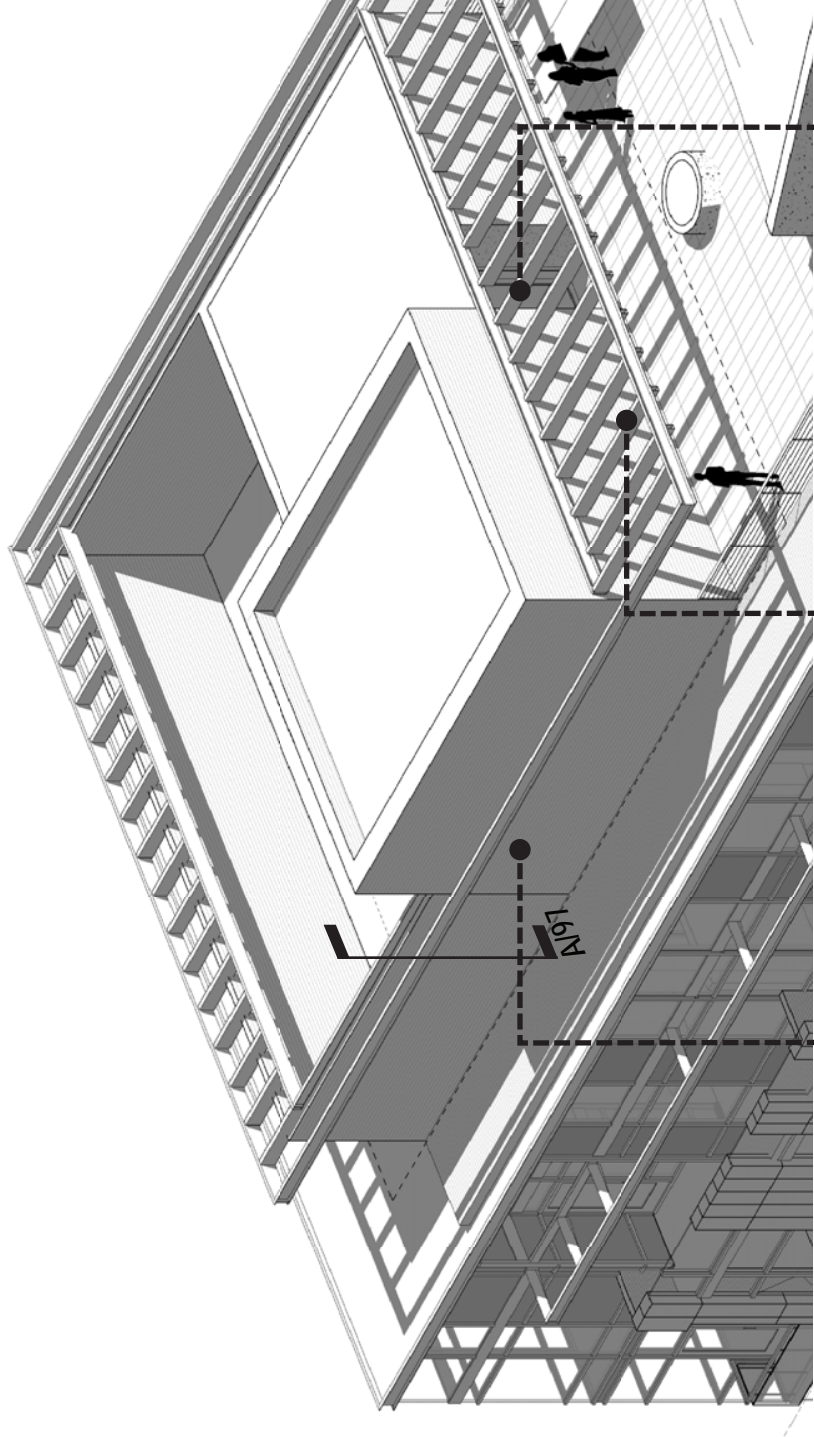

Aluminum Corrugated Panel



Painted Steel Trellis

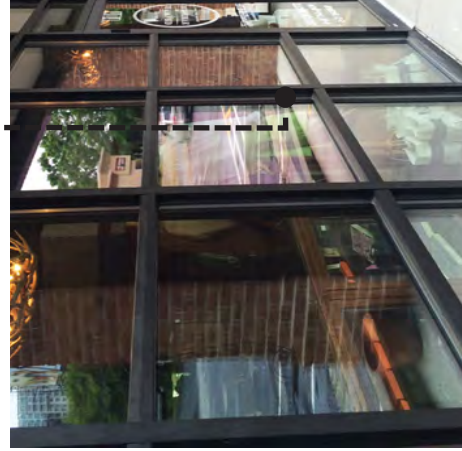

Storefront

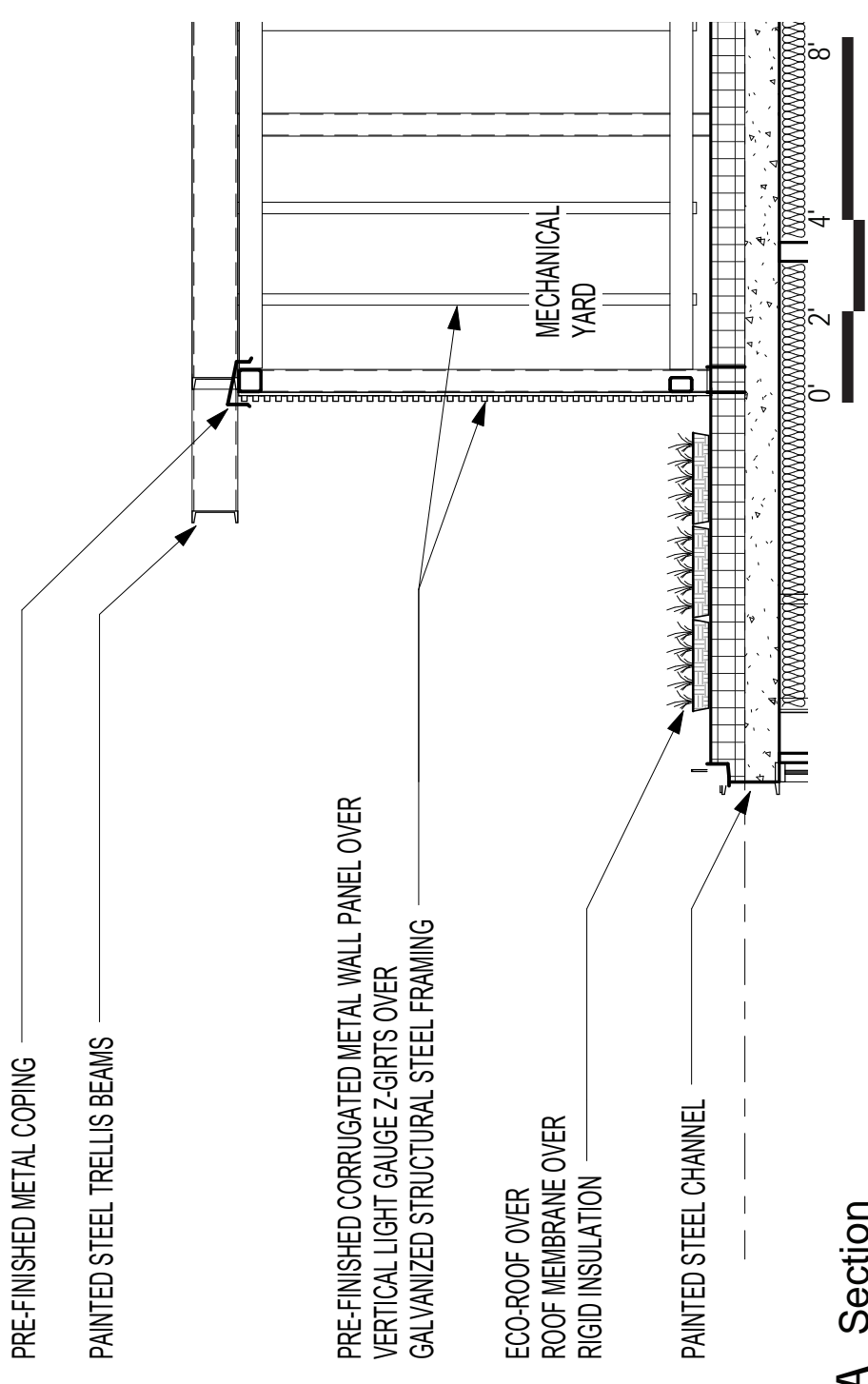



# 12th Ave Building Roof Terrace

Plan

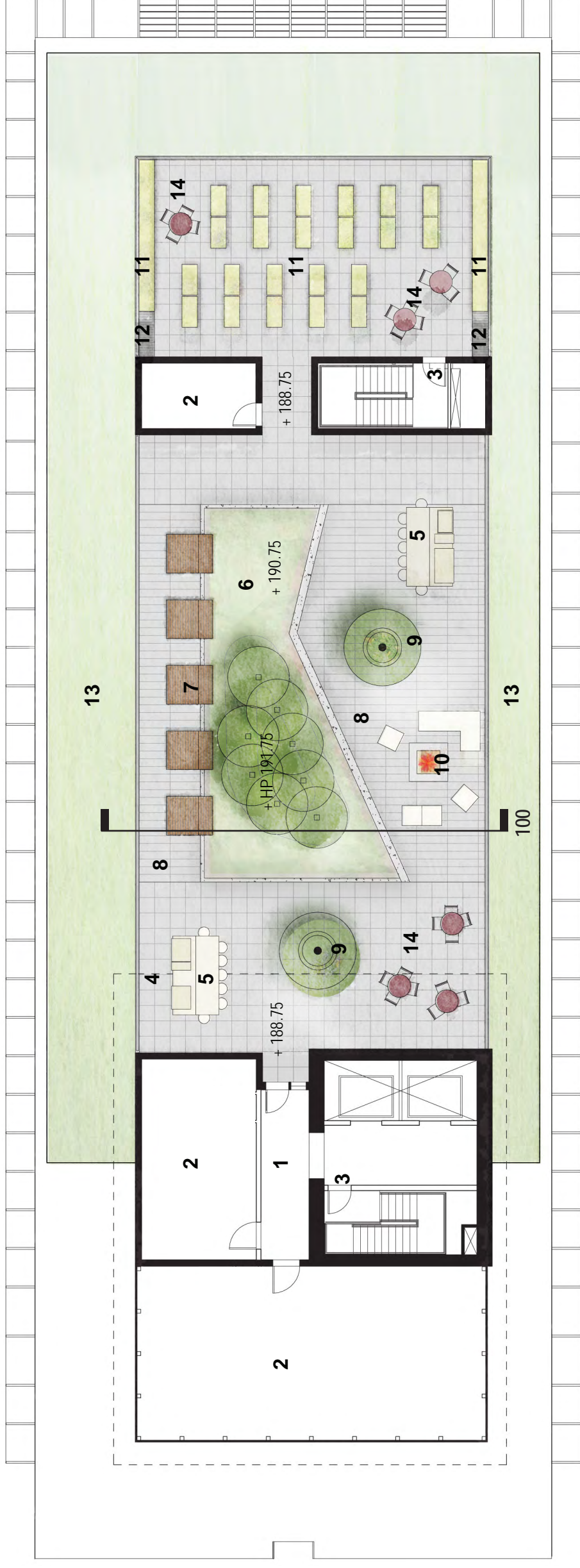

- 1 Main Entry, Elevator Lobby**  
Flush with level of concrete unit pavers
- 2 Mechanical Space**
- 3 Stair Entry**
- 4 Trellis Overhang**
- 5 Outdoor Kitchen, Total of 2**  
Bar height concrete counter with (1) gas grill, (1) sink, (1) mini-refrigerator. Seating for 6-8
- 6 Elevated Planting Area**  
Rooftop feature of protected grove of seedlings. Finished grade varies from 24"-36" above pavers. Articulated concrete wall and sun loungers on east and west sides.
- 7 Hardwood Chaise Lounge**  
Facing the river and protected from the other program areas by the elevated planter. 5' W is sized to accommodate 1-2 people, height is 12" above pavers
- 8 Paving Accent Zone**
- 9 Tree Planter**  
Precast concrete planter, 24" min. depth. Planted with medium sized trees to subdivide spaces
- 10 Fire Pit**  
Gas fire pit, approximately 18"H, located on west side for sunset and evening views. Surrounded by flexible furniture.
- 11 Community Gardens, 30-60 Plots**  
(30) 2x4 galvanized steel trough planters, paired. Can be further divided to create more plots.
- 12 Storage**  
Built in storage box, 2'H, 6'-10'L to accommodate gardening tools. Top serves as bench.
- 13 Green Roof** 4" planting depth
- 14 Flexible Space** Area for casual seating, dining overflow



# 12th Ave Building Roof Terrace

## Planting Plan



### 12th Ave Building Roof Terrace Plant Schedule

BOTANICAL NAME	COMMON NAME	SIZE	ROOT CONDITION	ON-CENTER SPACING
<b>TREE</b>				
<i>Betula jacquemontii</i>	HIMALAYAN BIRCH	2" CAL	CONTAINER	AS SHOWN
<i>Parrotia persica</i>	PERSIAN IRONWOOD	3" CAL	CONTAINER	AS SHOWN
<b>GROUND COVER</b>				
<i>Allium senescens</i> var. <i>glaucum</i>	CIRCLE ONIION	1 GAL	CONTAINER	12" O.C.
<i>Deschampsia cespitosa</i> 'Goldtau'	TUFTED HAIR GRASS	1 GAL	CONTAINER	12" O.C.
<i>Sedum 'Matrona'</i>	AUTUMN STONECROP	1 GAL	CONTAINER	12" O.C.
<i>Sesleria autumnalis</i>	AUTUMN MOOR GRASS	1 GAL	CONTAINER	12" O.C.
<b>GREEN ROOF MIX</b>				

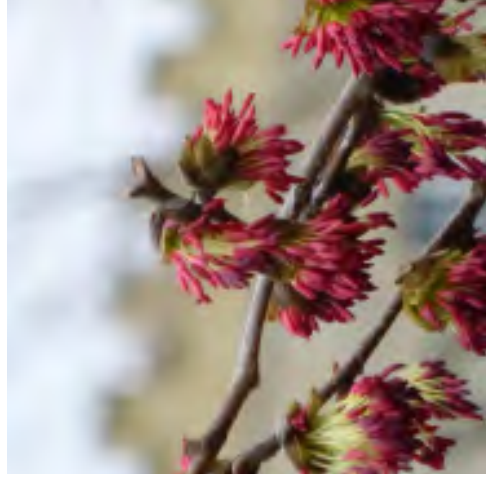

Parrotia *Parrotia persica*

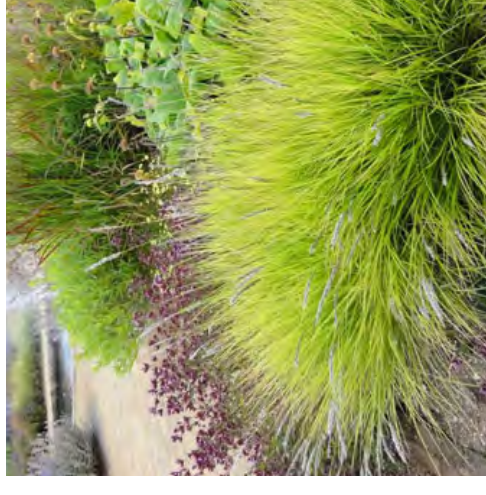

Autumn Moor Grass *Sesleria autumnalis*



Tufted Hairgrass *Deschampsia cespitosa*



Allium *Allium* spp.



Autumn Stonecrop *Sedum 'Matrona'*



Green roof *Sedum* spp.

# 12th Ave Building Roof Terrace

Section

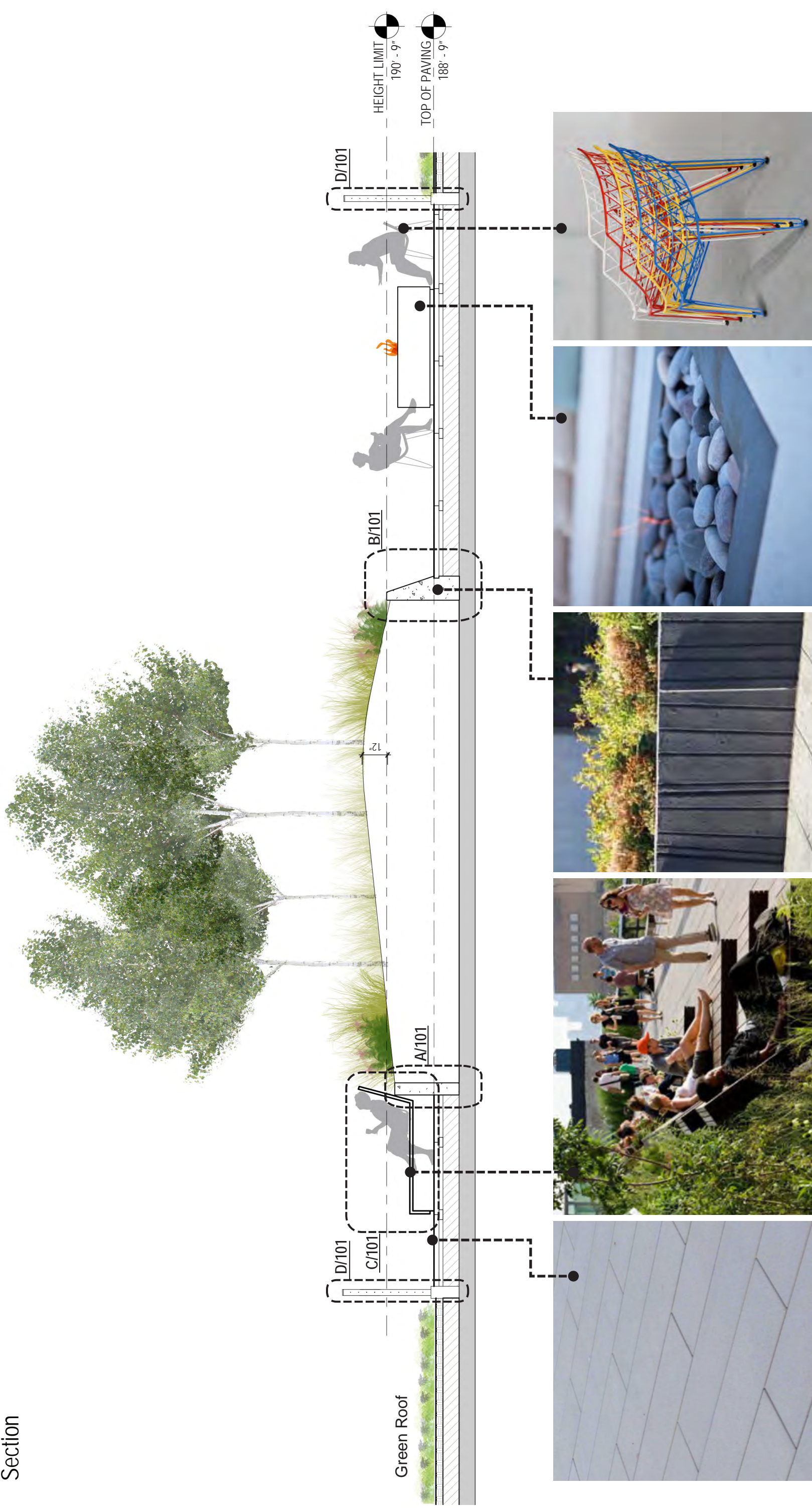

Accent Pavers  
Stepstone, 12" x 36" Precast Concrete,  
Pedestal set



Sun Loungers



Concrete Accent Wall

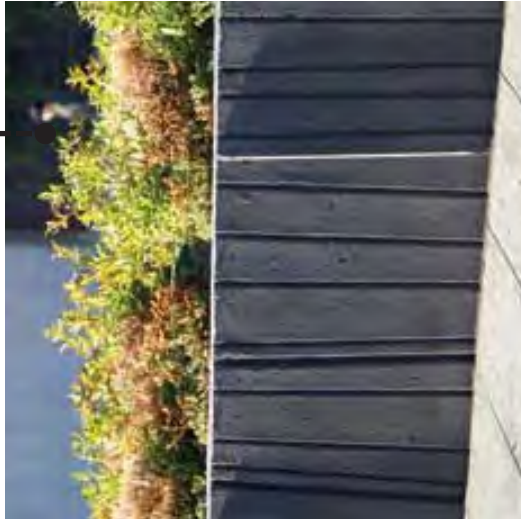

Fire Pit

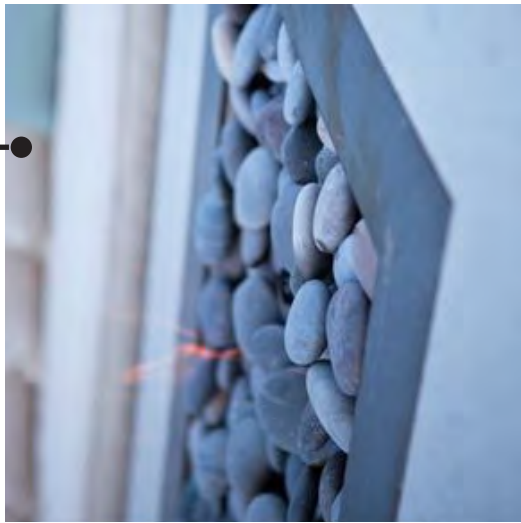

Colorful Accent Furniture

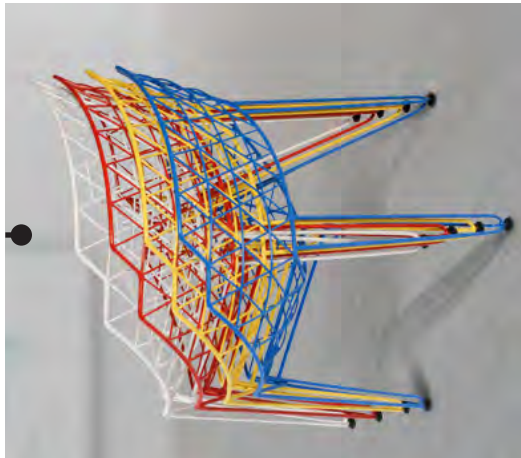

# 12th Ave Building Roof Terrace

## Details

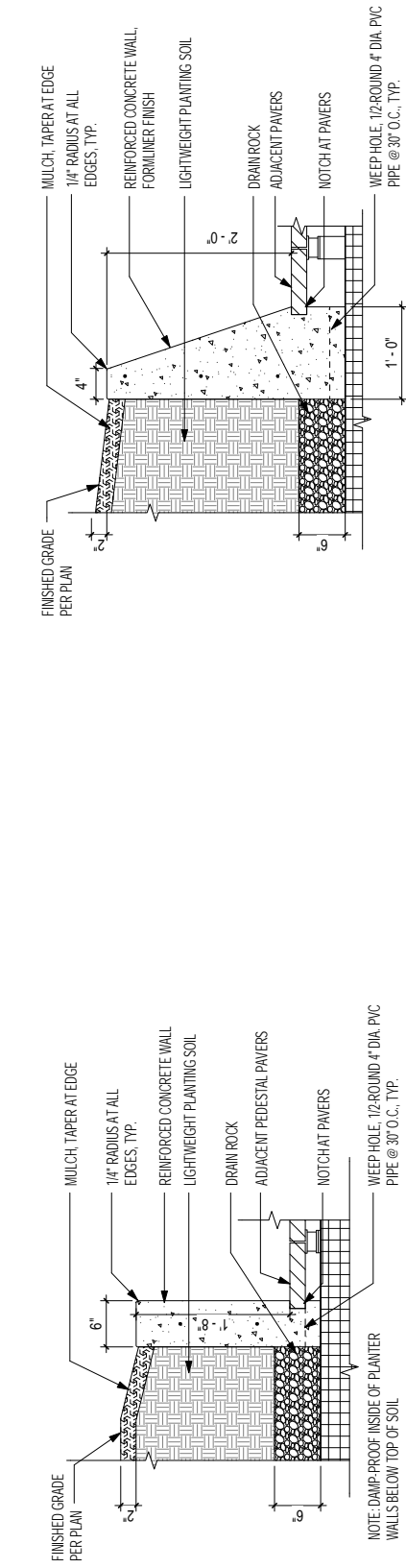

A Concrete Planter Wall Detail

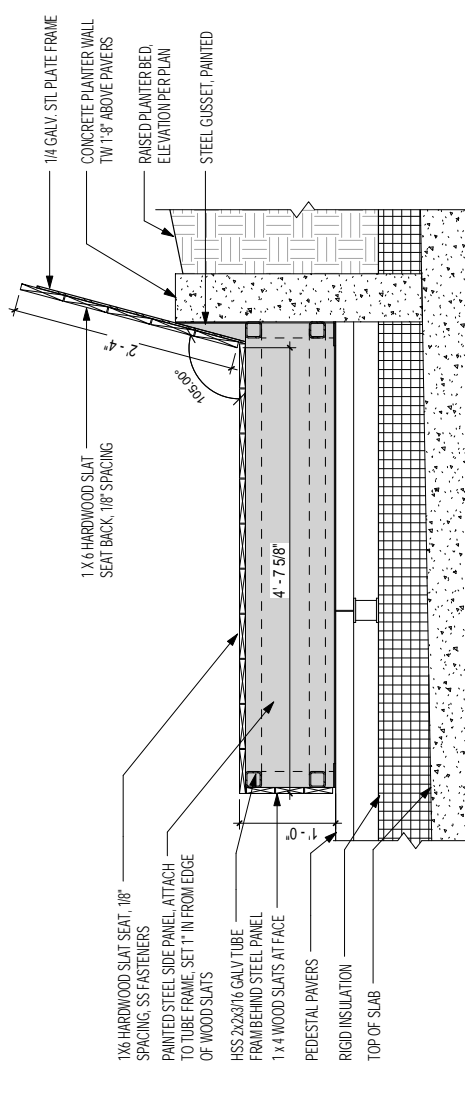

C Sun Lounger Detail

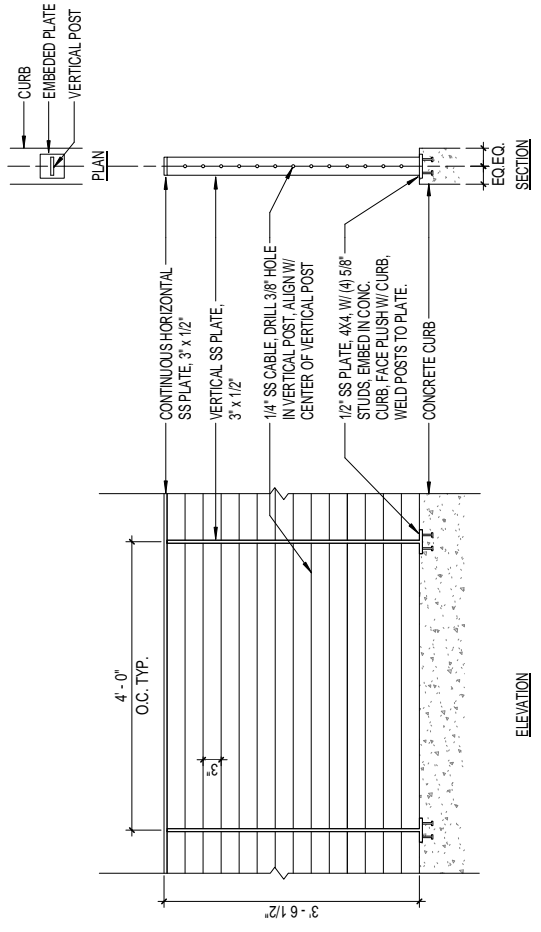

D Cable Rail Detail



B Concrete Accent Wall Detail



Outdoor Kitchen  
Concrete counter with (1) gas grill, (1) sink, (1) mini-refrigerator



Concrete Planters  
Greenform, Delta Round 30\"/>

# 13th Avenue Building

View along 13th Avenue



# 13th Avenue Building

## Ground Level Plan

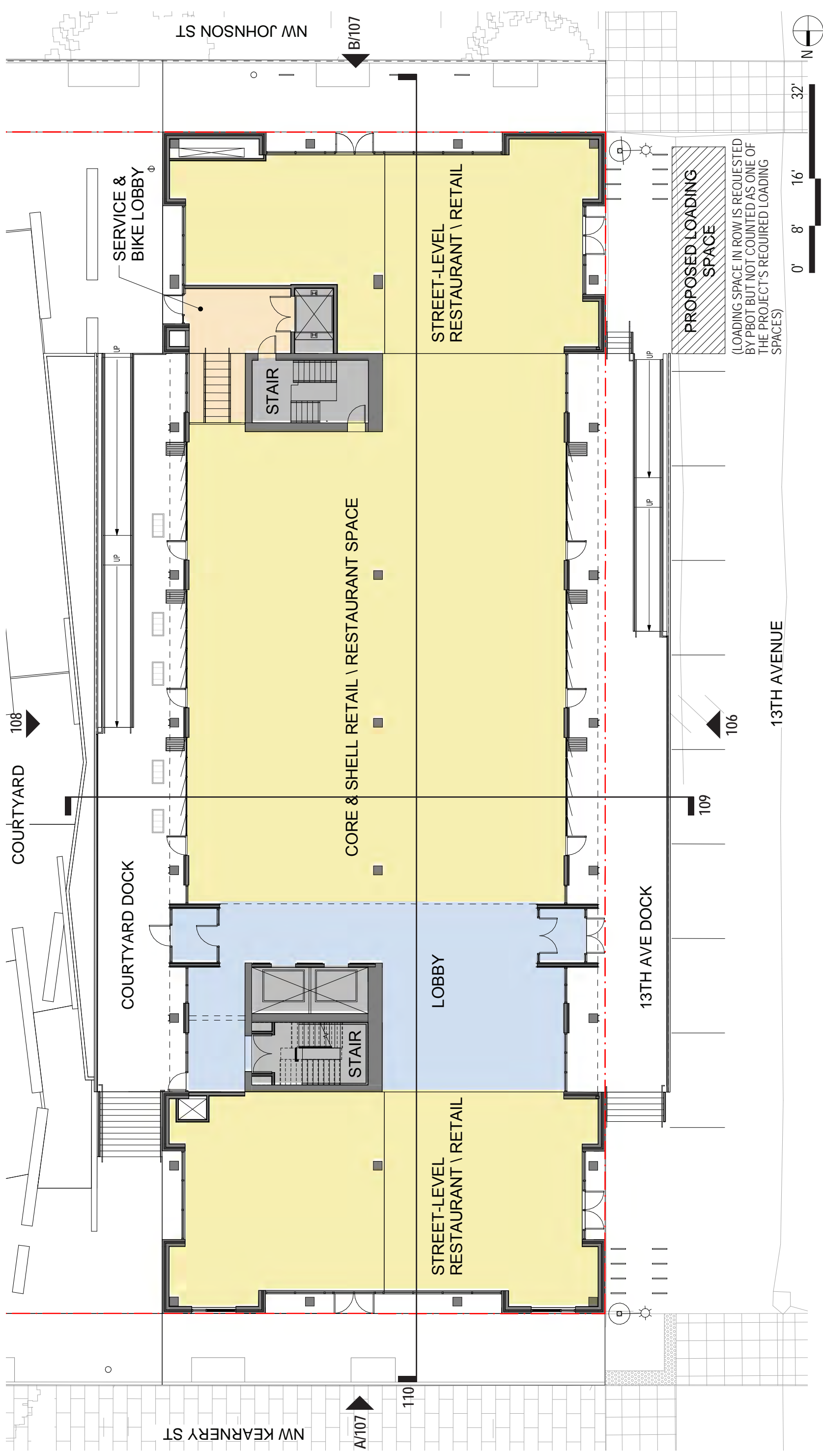

# 13th Avenue Building

## Typical Office Level Plan

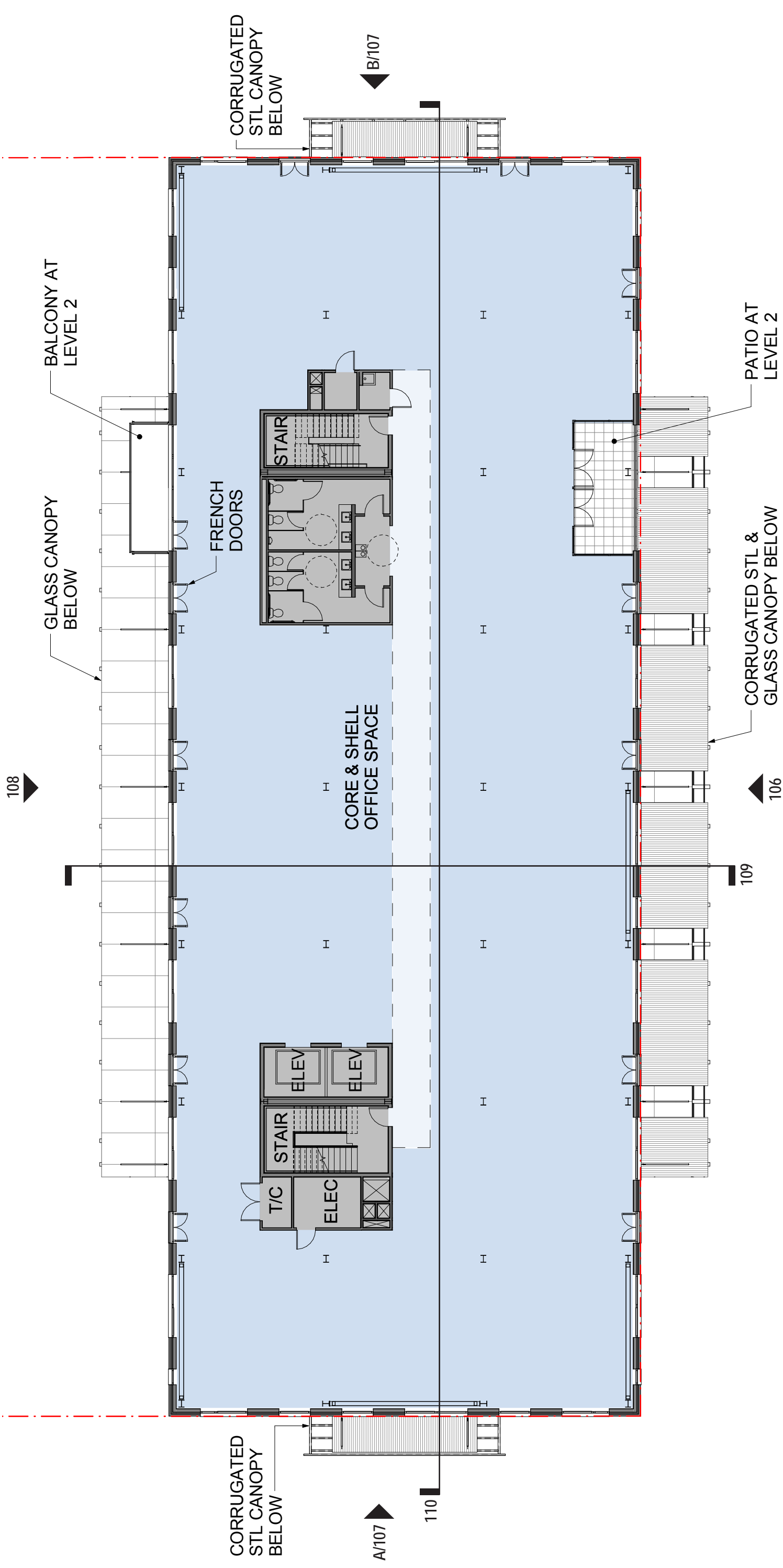

# 13th Avenue Building

## Roof + Mechanical Enclosure Plan

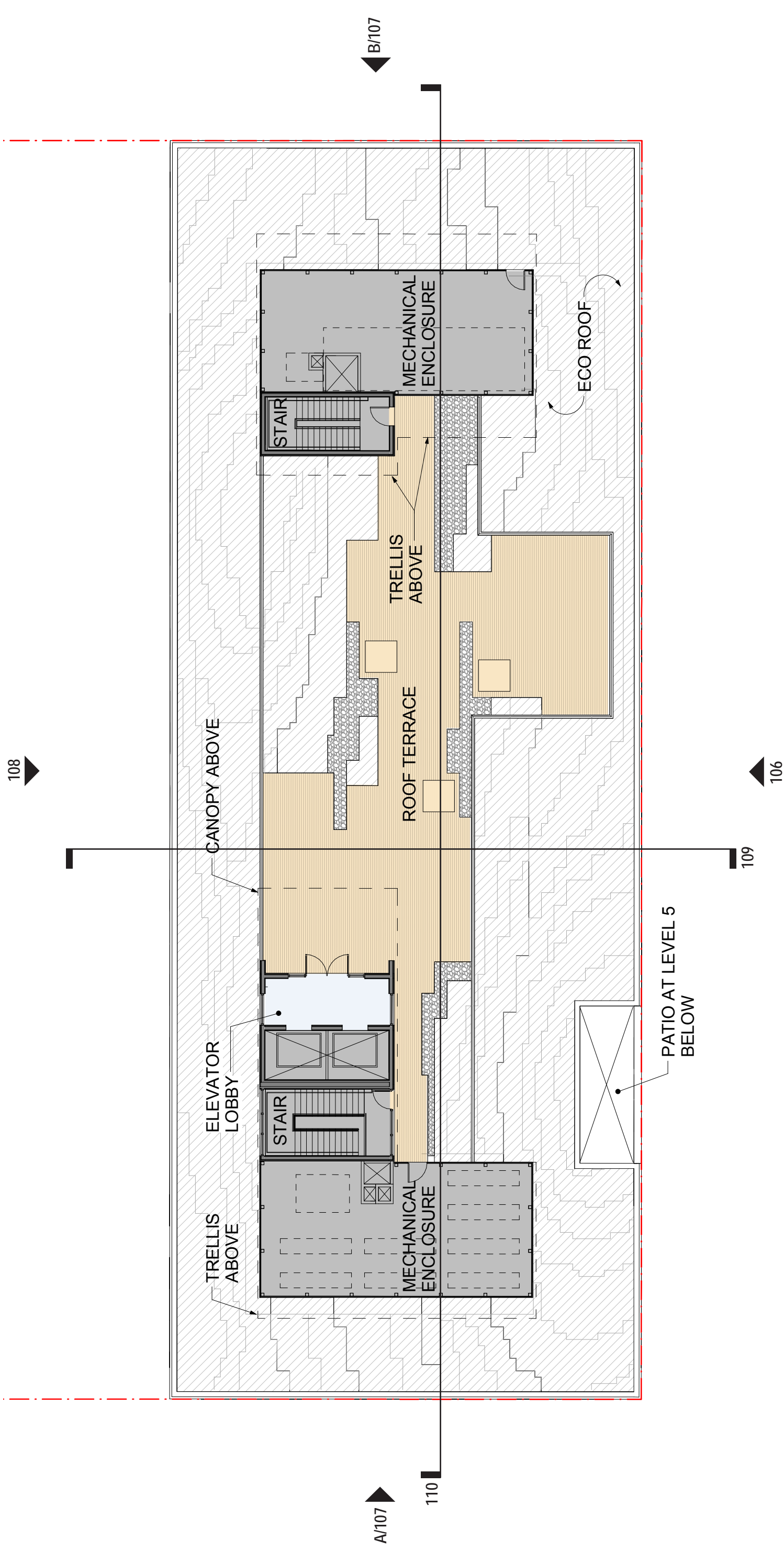



# 13th Avenue Building

West Elevation at 13th Avenue

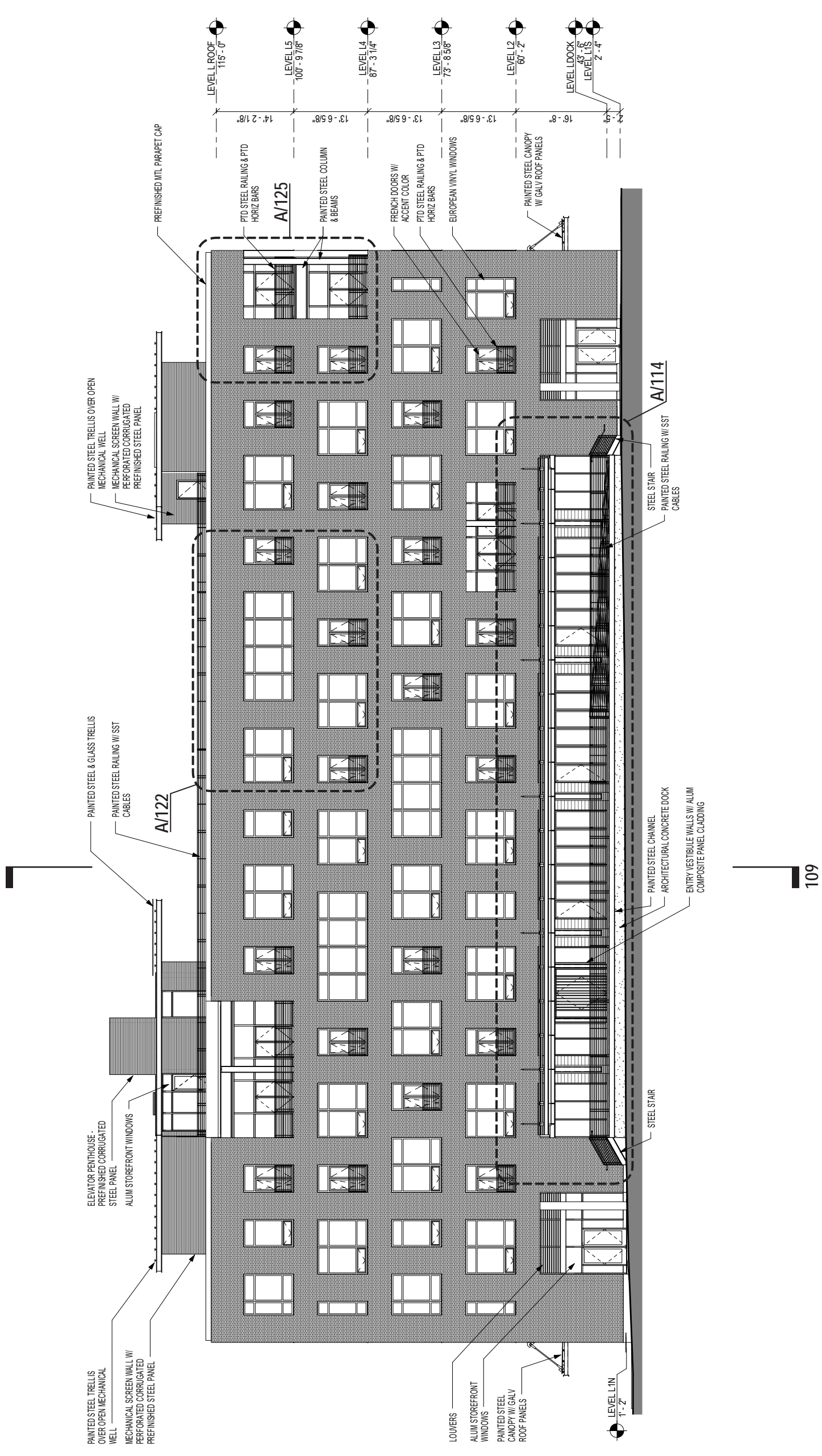

# 13th Avenue Building

## North & South Elevations

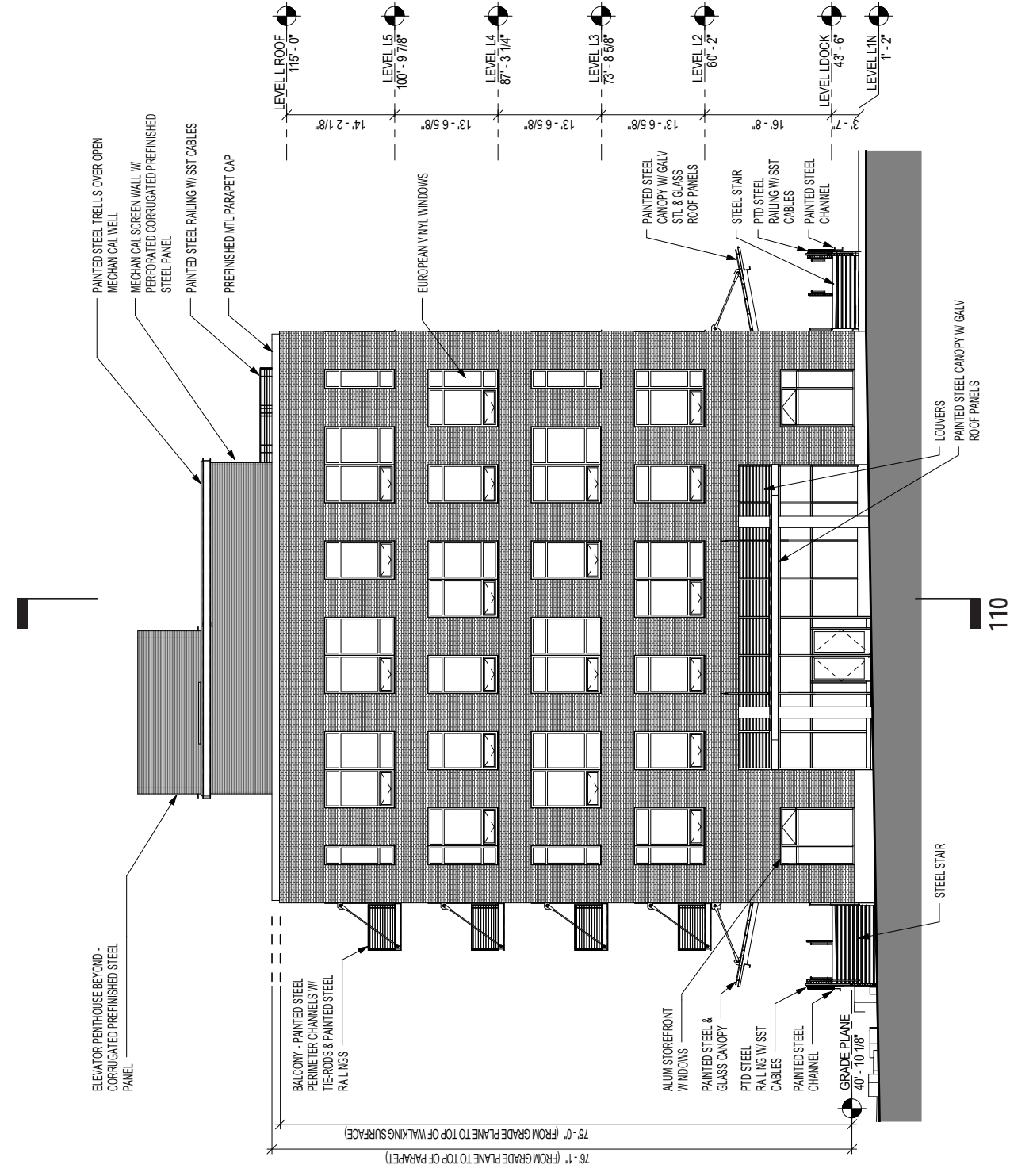

A North Elevation at NW Kearney St

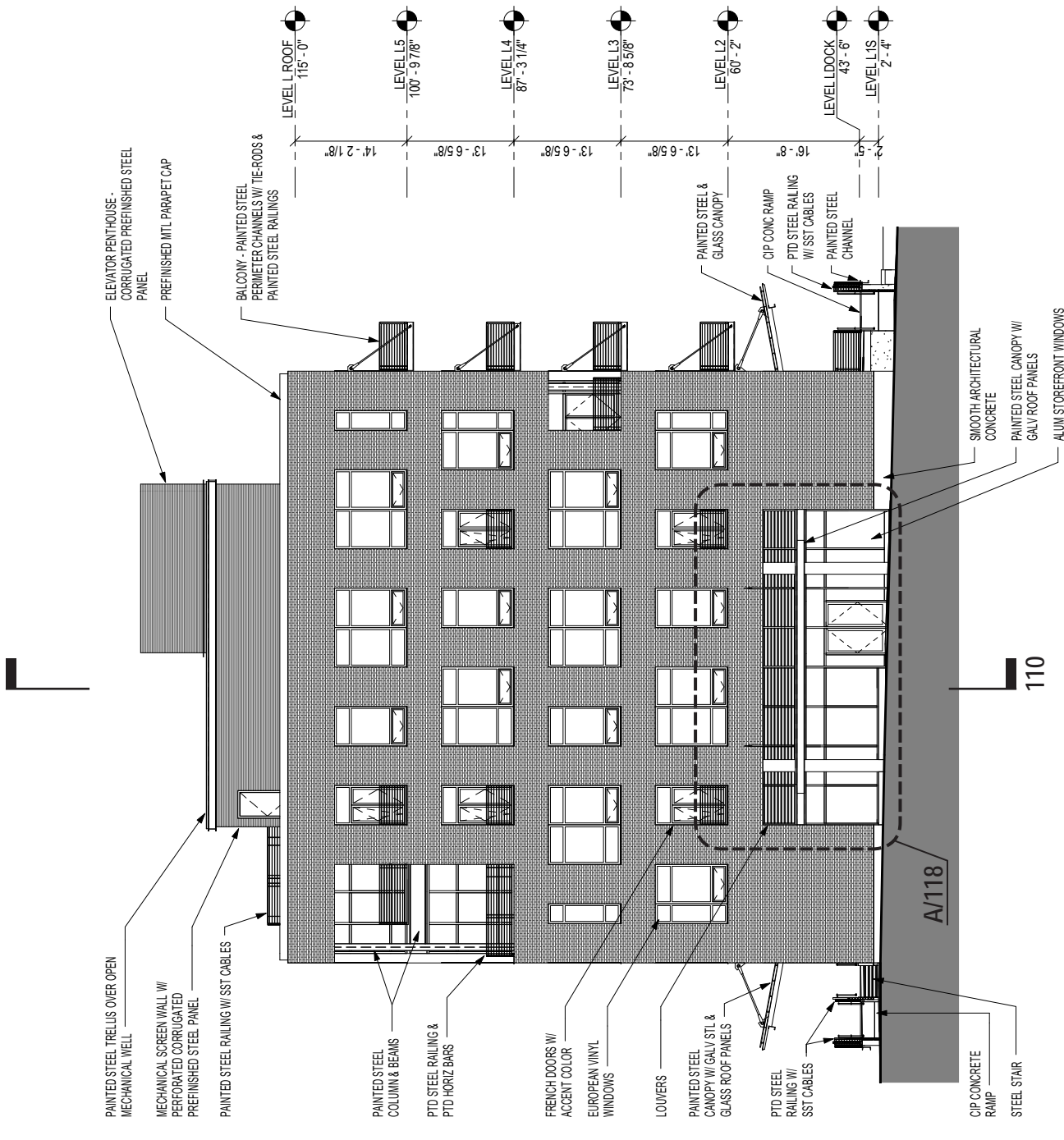

B South Elevation at NW Johnson St

# 13th Avenue Building

East Elevation at Courtyard

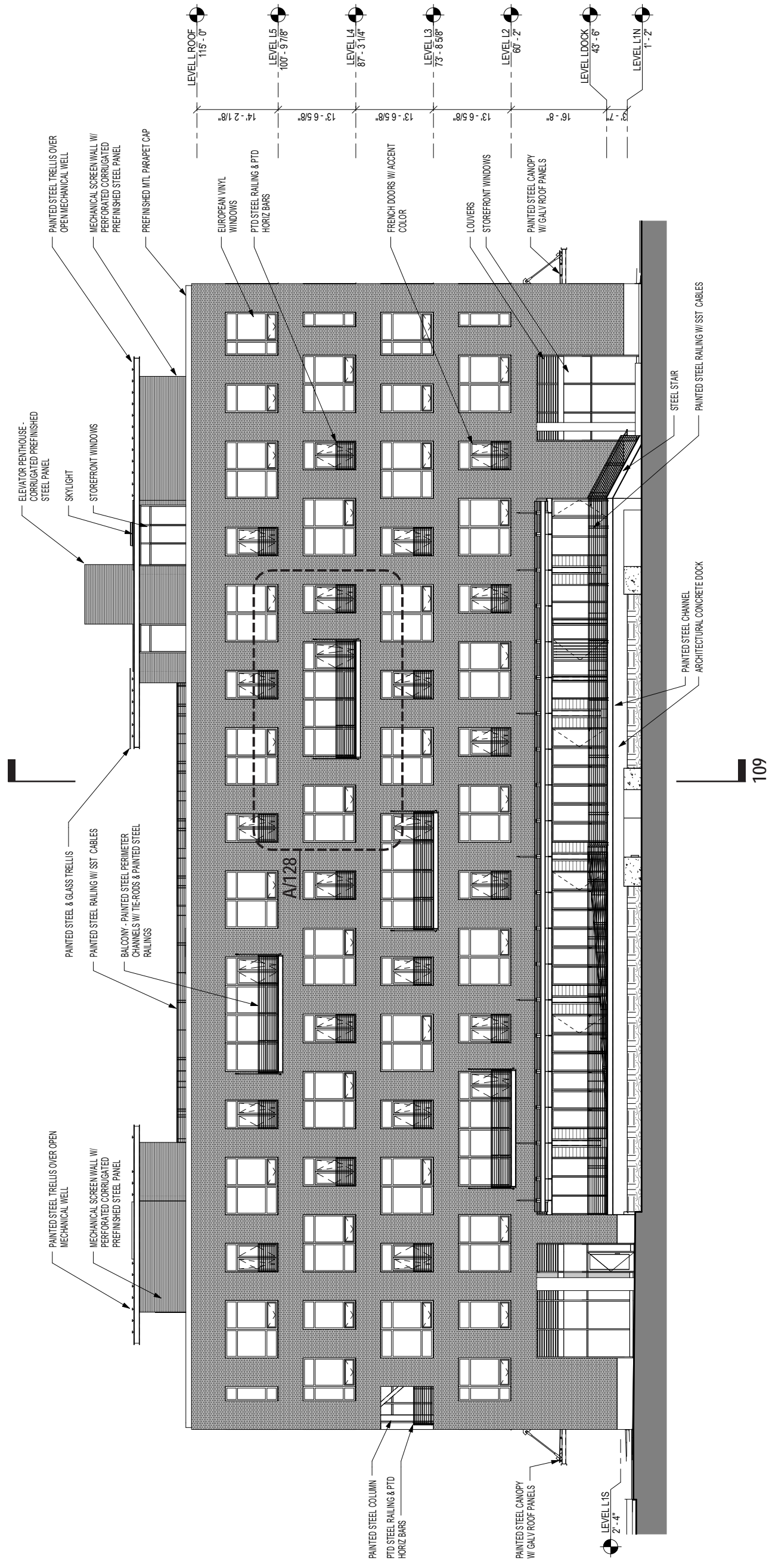

# 13th Avenue Building

## Building Section at Docks

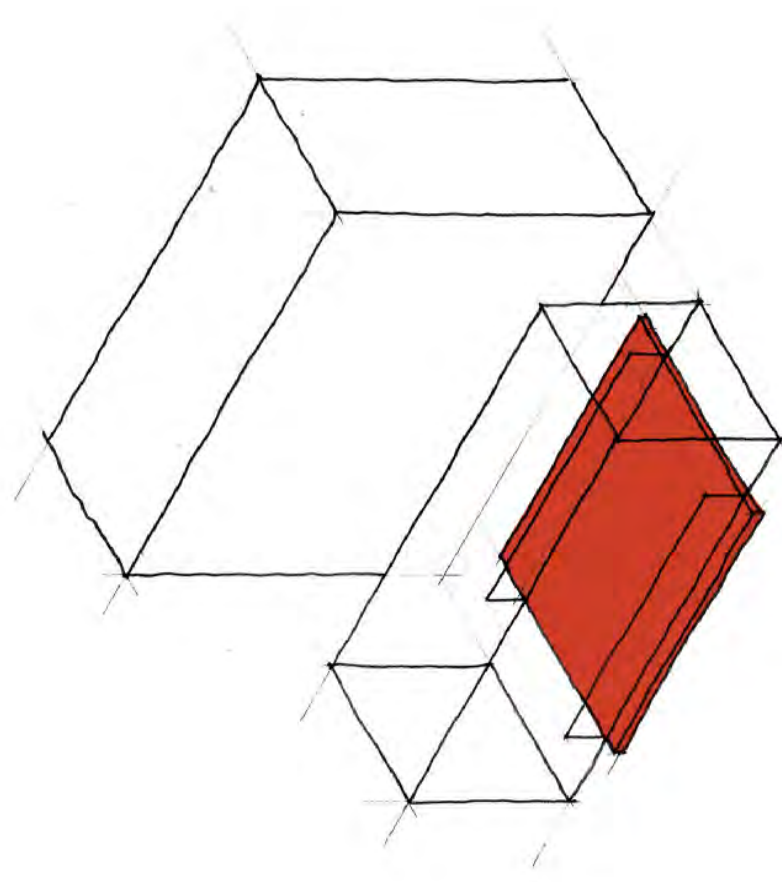
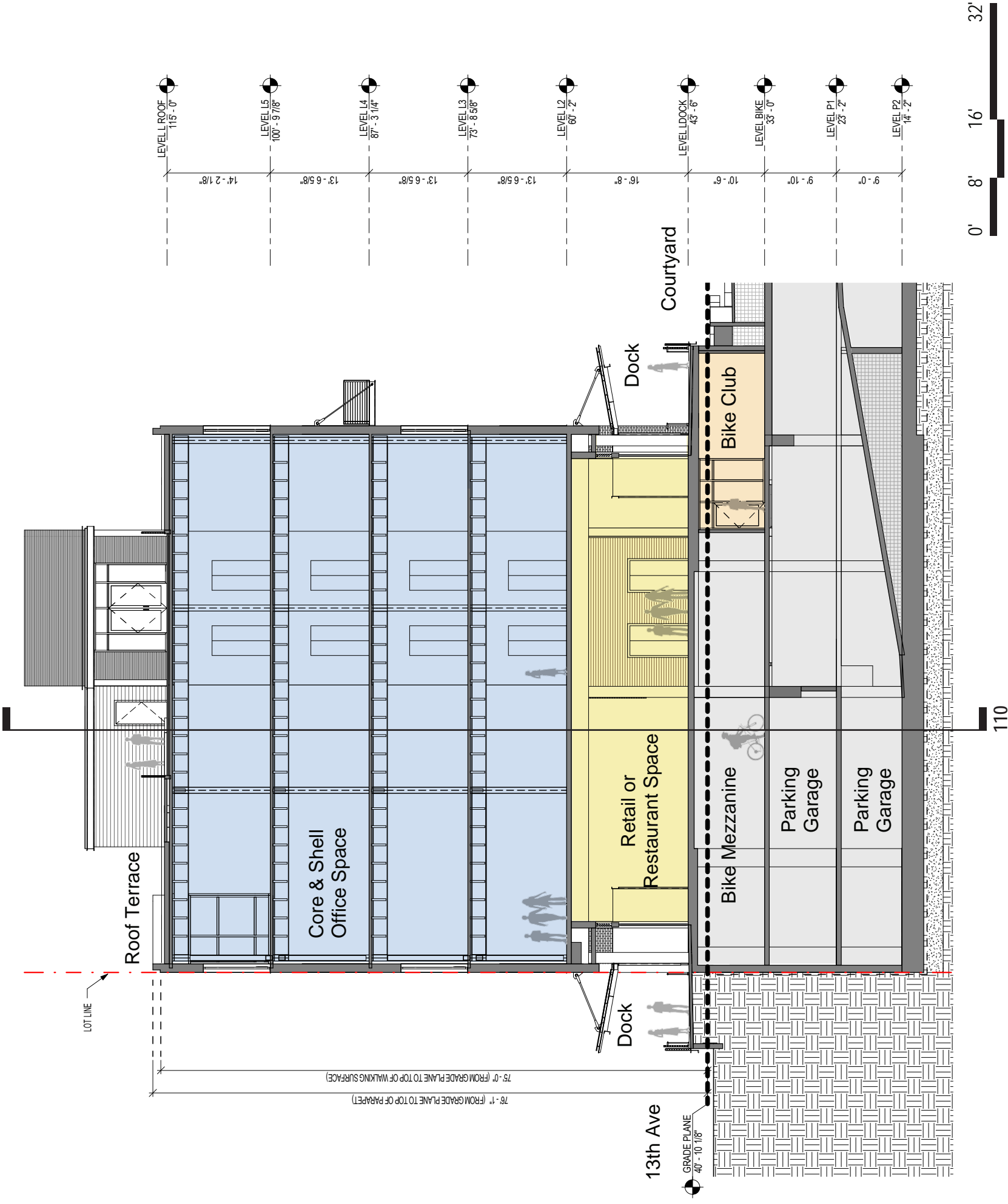

Dock Diagram

# 13th Avenue Building

## Building Section at On-Grade Retail

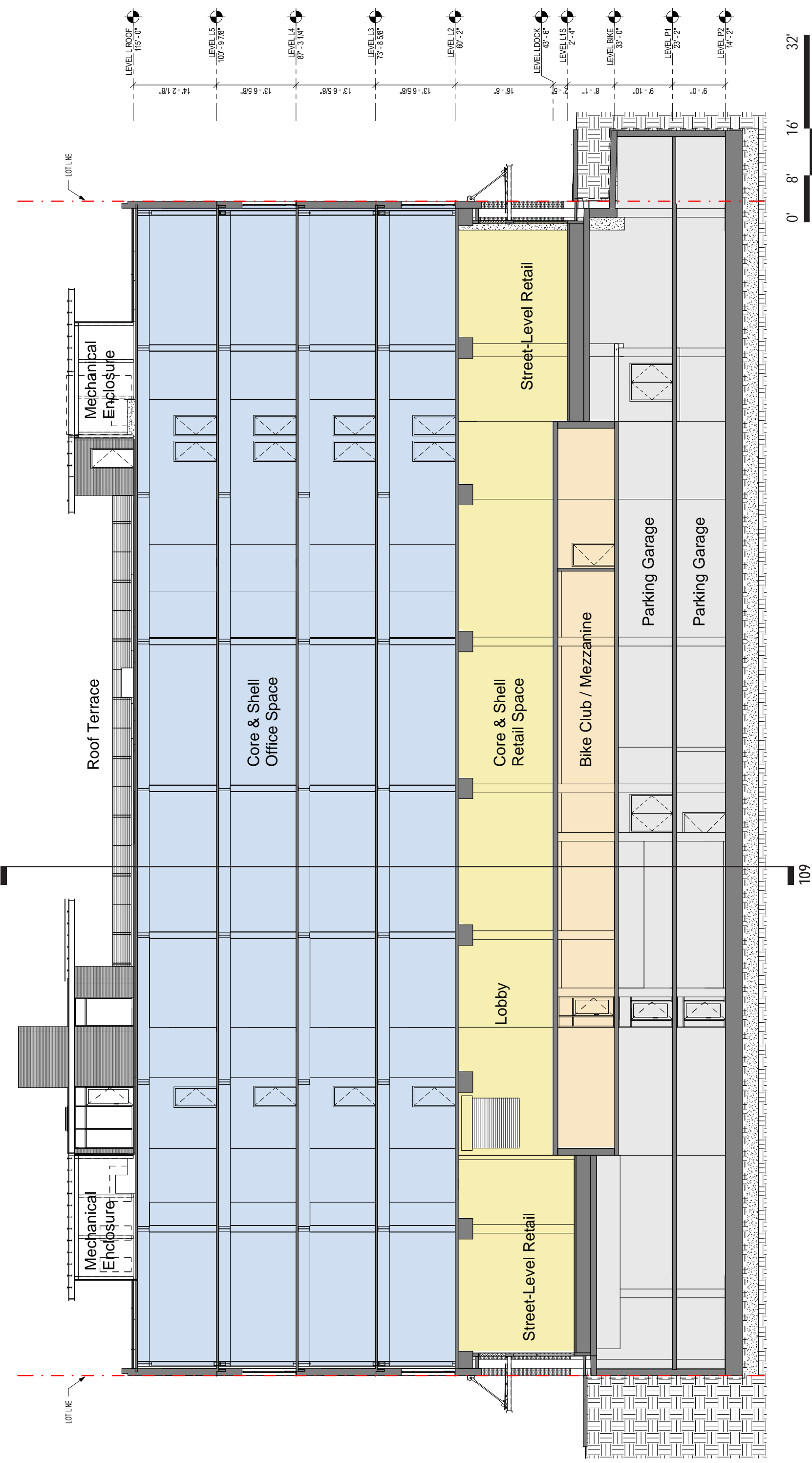

# 13th Avenue Building

## Materials Palette

### Top



Painted steel trellis



Painted steel rails w/ SST cables



Prefin. metal parapet cap



Steel Corrugated Panel



Ipe decking



Green roof

### Middle



Painted steel structure



Brick



Painted steel rails w/ horiz. rods



Colorful french doors

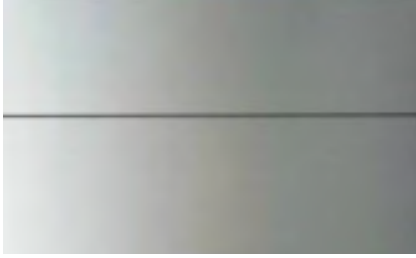

Alum Composite Panel



European vinyl window

### Bottom



Painted steel structure



Brick



Painted steel rails w/ SST cables



Storefront window

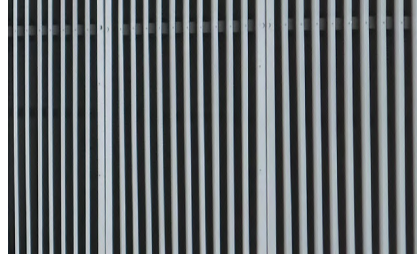

Metal louver



Concrete

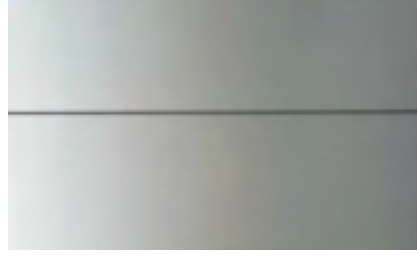

Alum Composite Panel



Wood soffits

# 13th Avenue Building Details

## Pearl District Dock Context

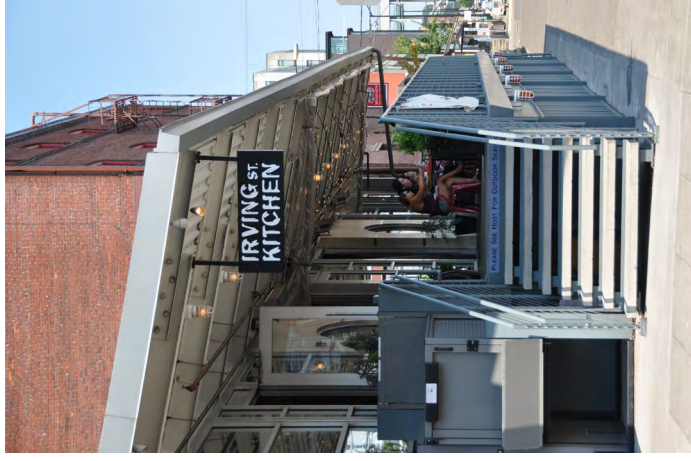
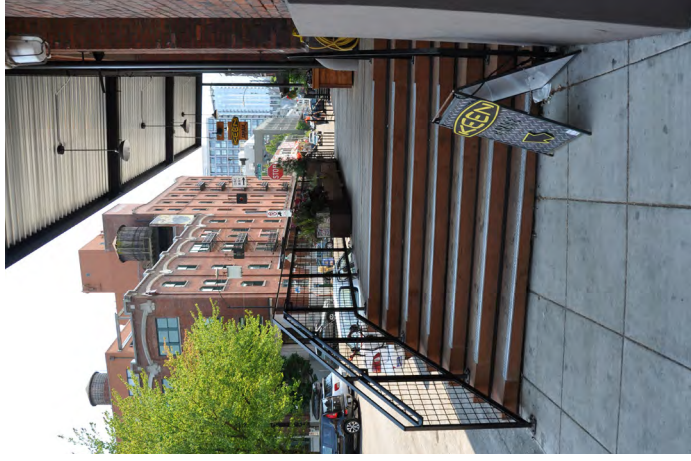

### Dock Principles:

- Elevate the dock at least 36" above street level
- Provide separate stairs outside the dock boundary - steel stairs are best
- Provide accessible ramp within dock footprint
- Use concrete or wood for the dock surface
- Provide a steel canopy
- Provide transparency and multiple doors onto the dock
- Have an industrial attitude

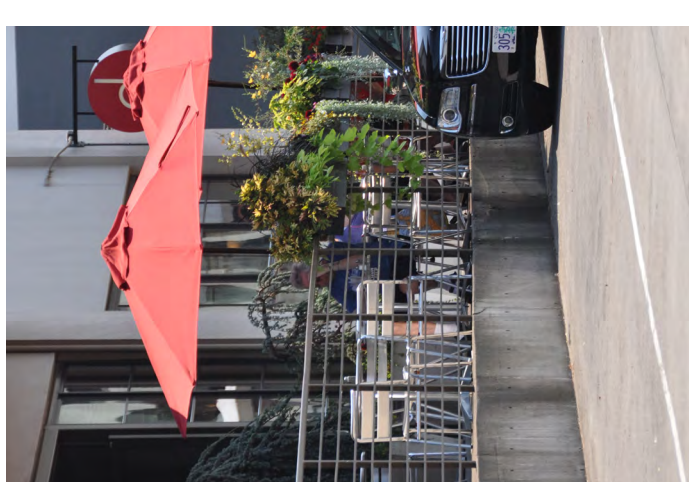
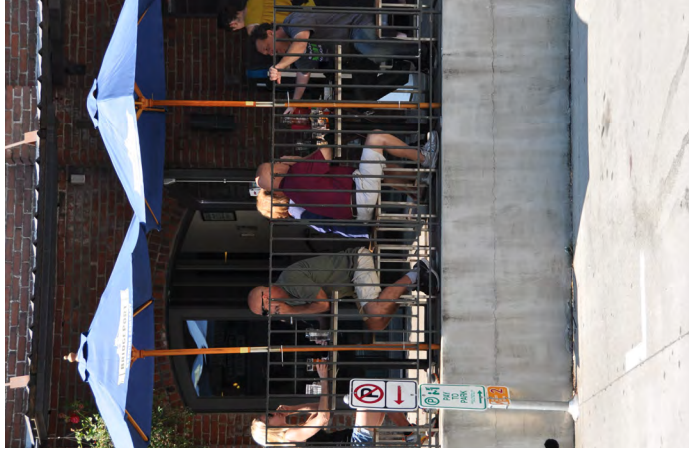
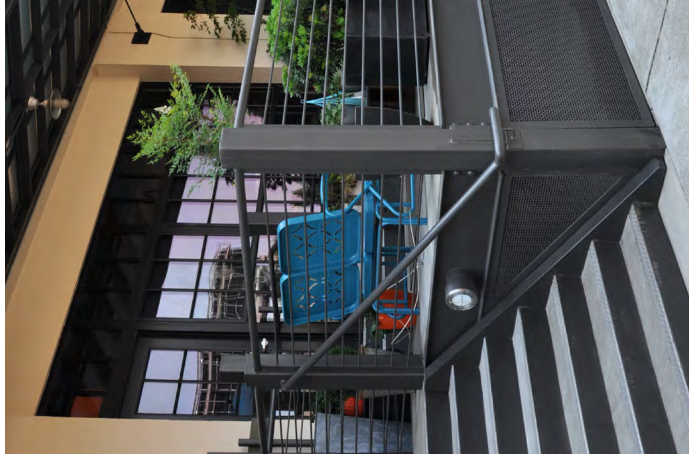
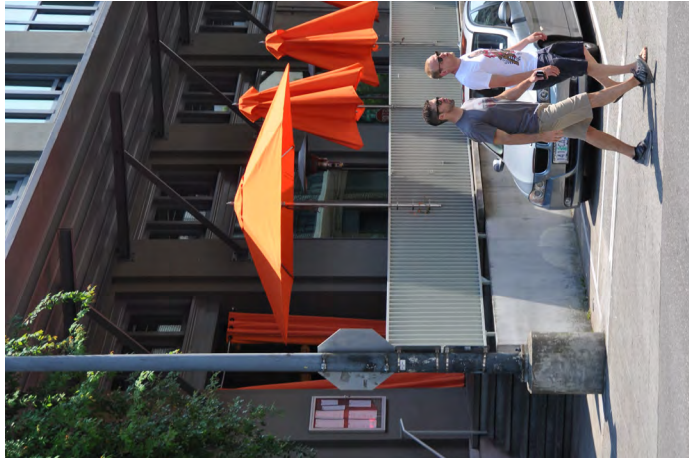

# 13th Avenue Building Details

Pearl District Dock Context

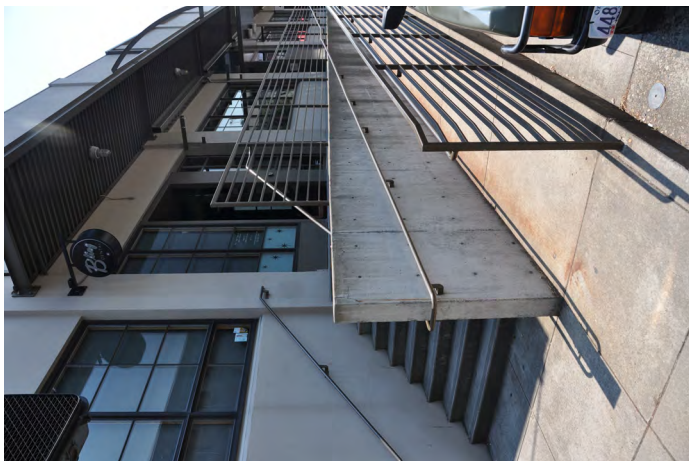
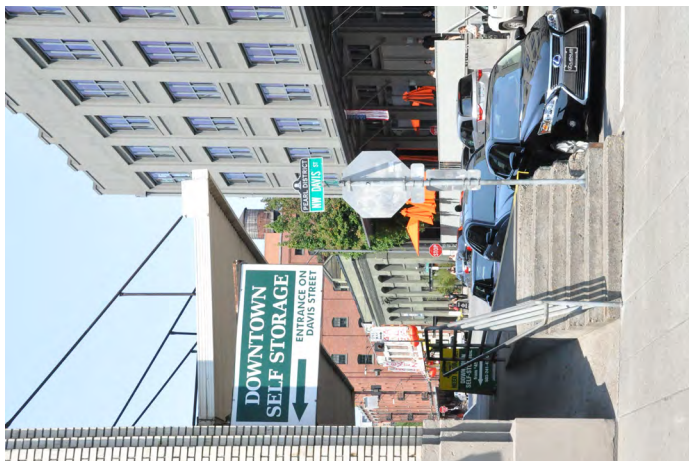
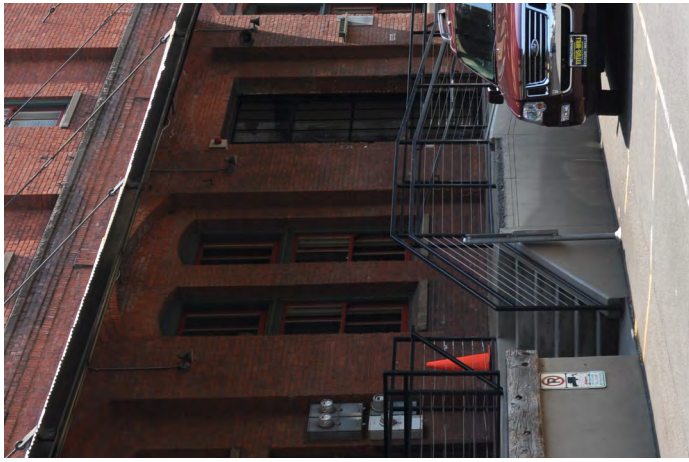



# 13th Avenue Building Details

13th Avenue Ground Level



A Elevation

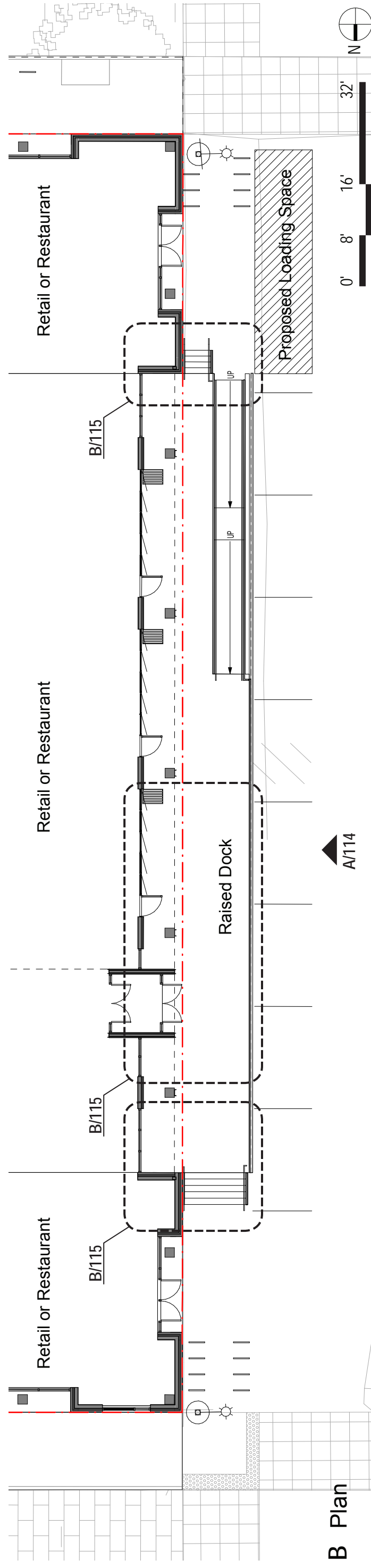

B Plan

# 13th Avenue Building Details

Dock on 13th Avenue

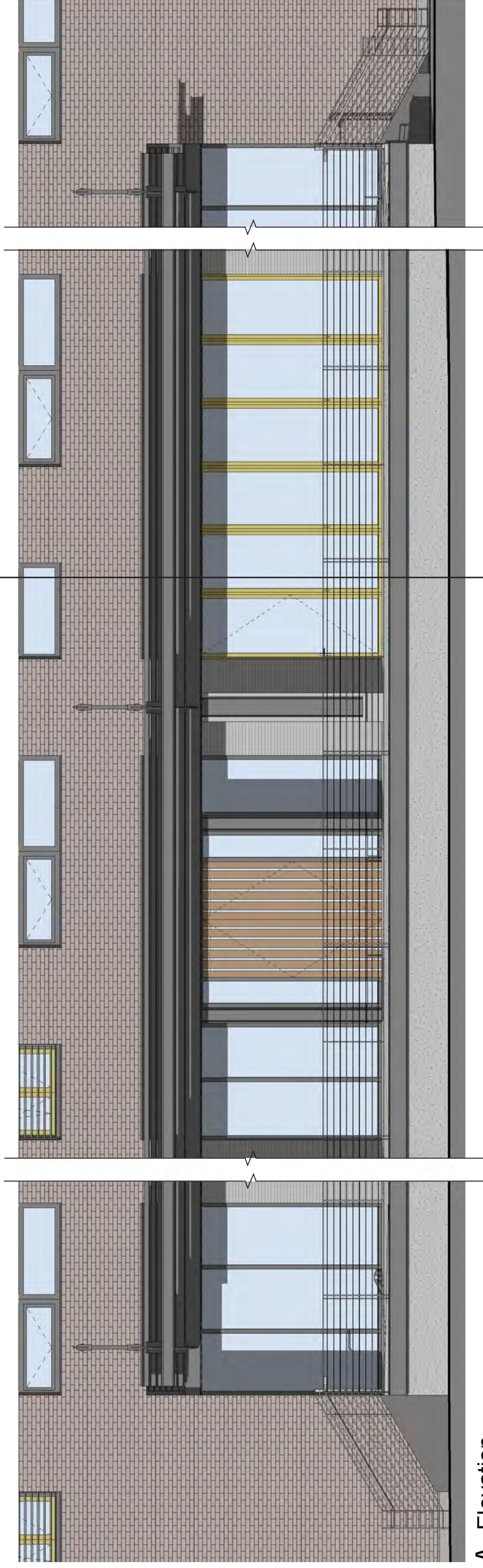

A Elevation

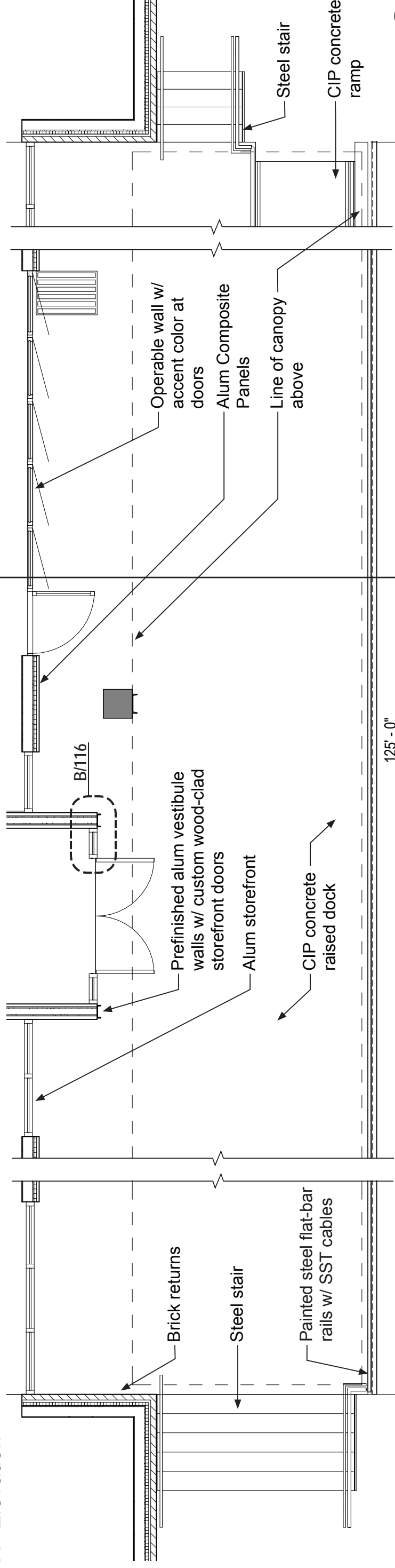

B Plan

Operable wall w/  
accent color at  
doors

Alum Composite  
Panels

Line of canopy  
above

B/116

Prefinished alum vestibule  
walls w/ custom wood-clad  
storefront doors

Alum storefront

CIP concrete  
raised dock

Brick returns

Steel stair

Painted steel flat-bar  
rails w/ SST cables

Steel stair  
CIP concrete  
ramp

125' - 0"

0' 2' 4' 8'



A/115

A/116

# 13th Avenue Building Details

Dock on 13th Avenue



Rendering at 13th Avenue Dock

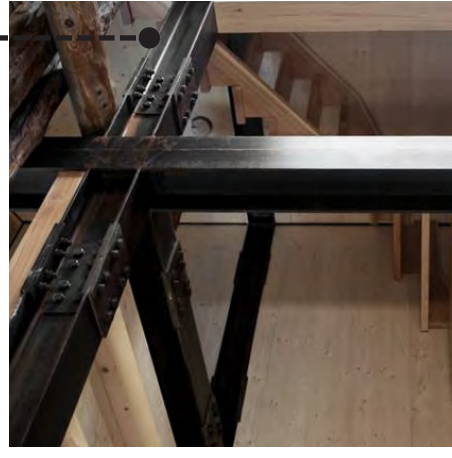

Painted steel structure



Concrete



Folding storefront



Painted steel flat-bar rails w/ SST cables

Alum Composite Panels

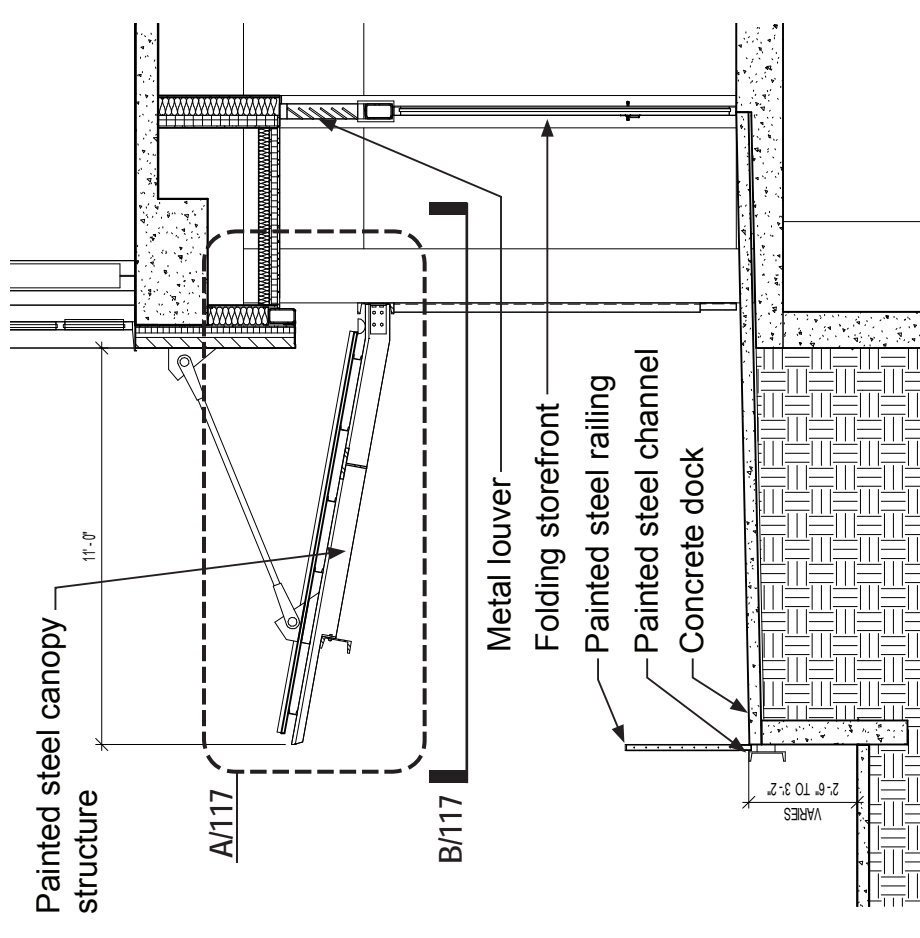

A Section at Dock, Typ

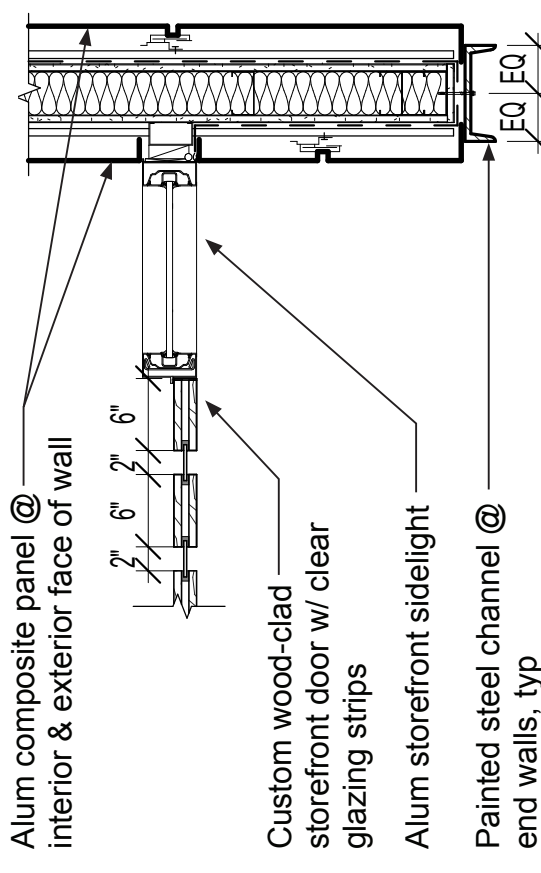

B Jamb @ Vestibule Door, Typ

# 13th Avenue Building Details

Dock on 13th Avenue

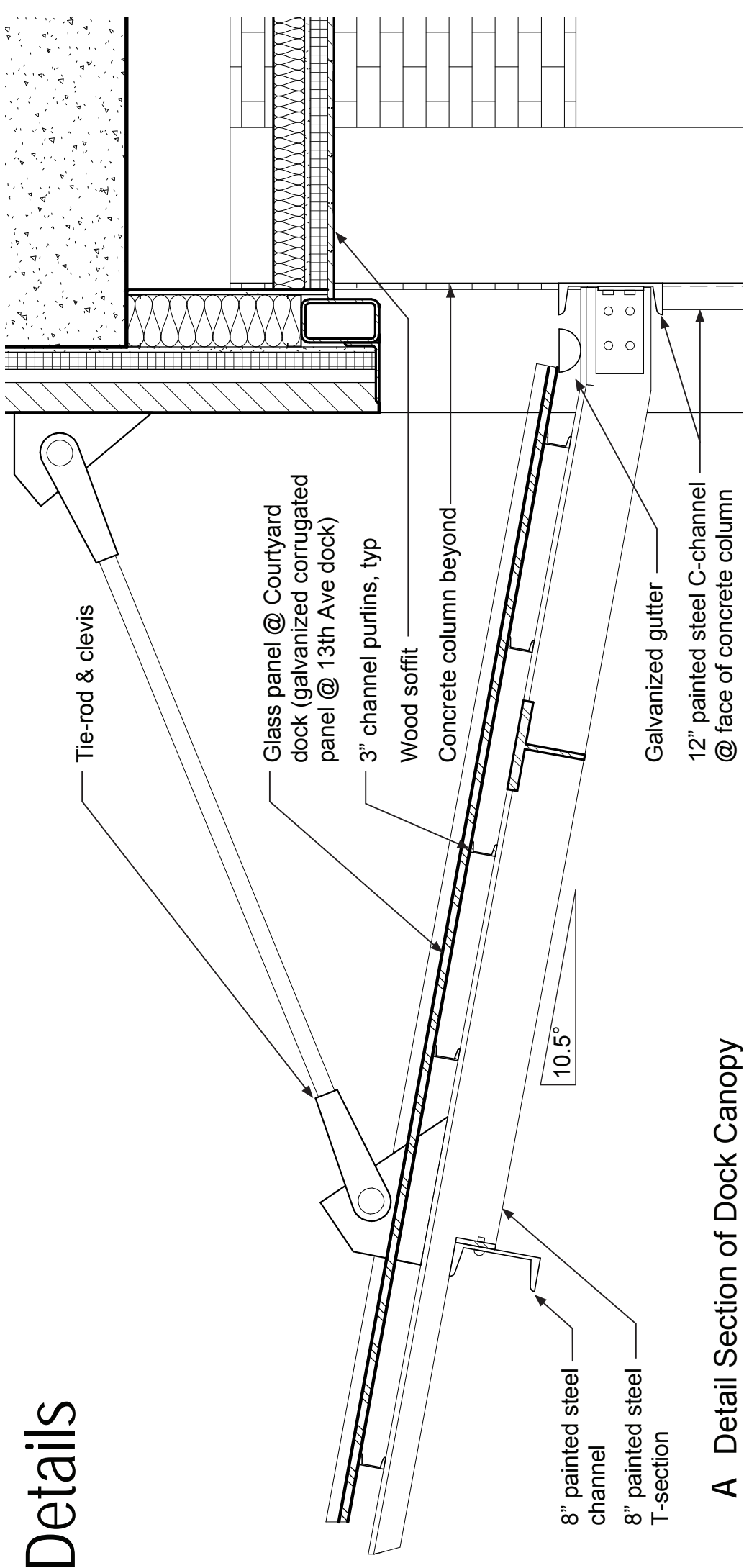

A Detail Section of Dock Canopy

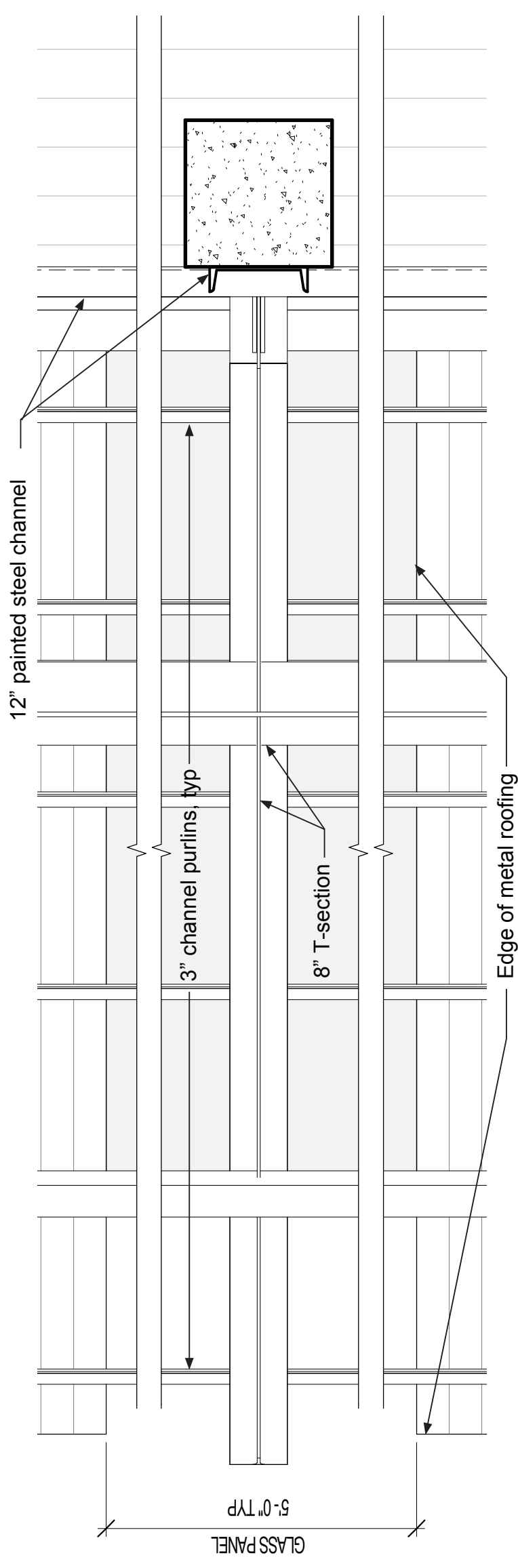

B Reflected Ceiling Plan of Canopy

# 13th Avenue Building Details

North + South Retail Entries



A Elevation

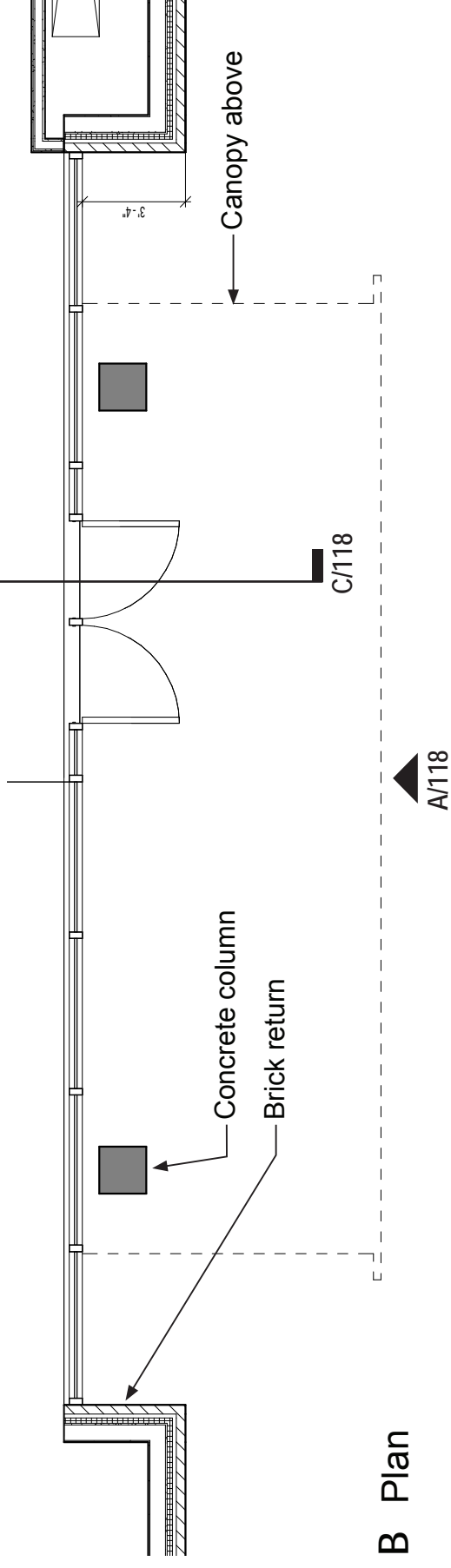

B Plan

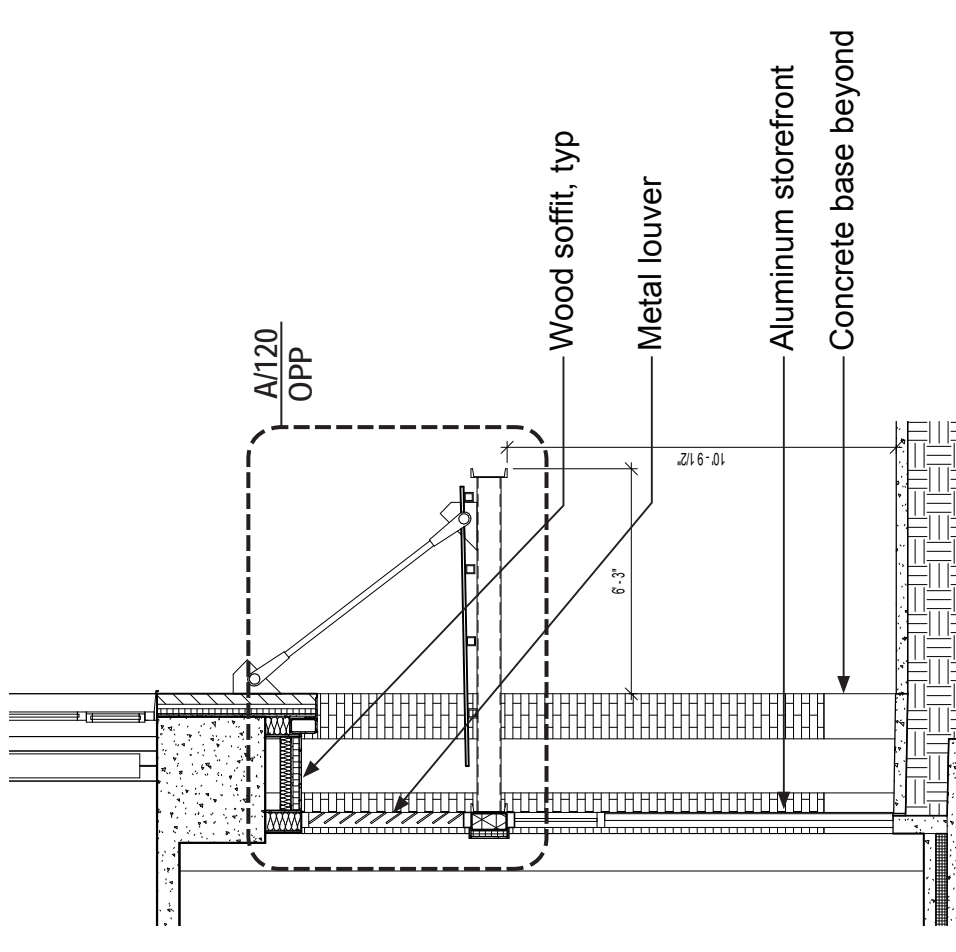

C Section

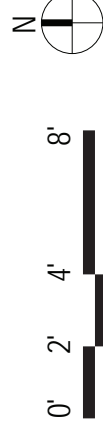

# 13th Avenue Building Details

North + South Retail Entries

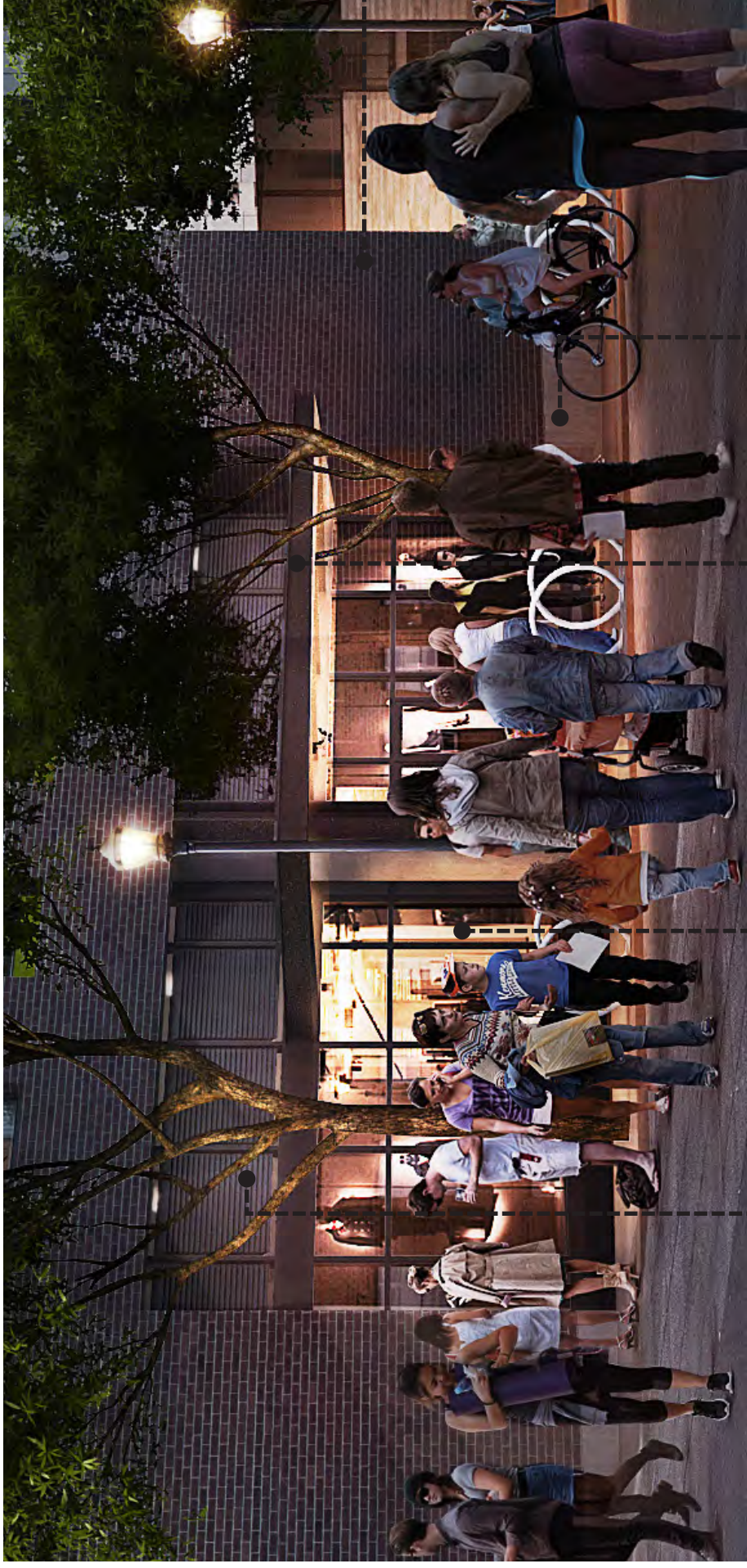

Rendering at South Retail Entry



Metal louvers



Storefront

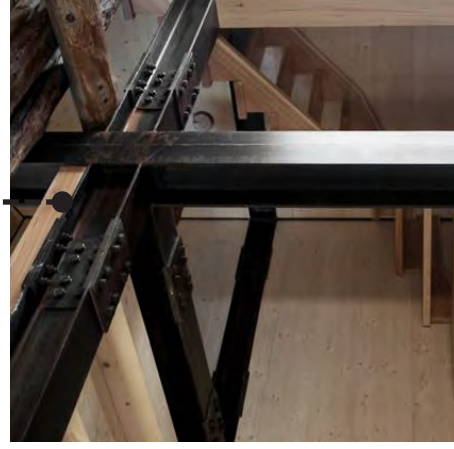

Painted steel structure

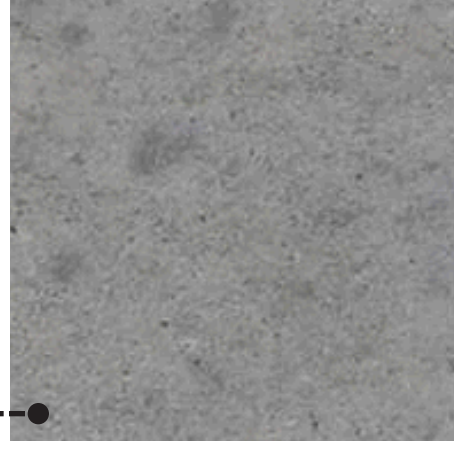

Concrete



Brick

# 13th Avenue Building Details

North + South Retail Entries

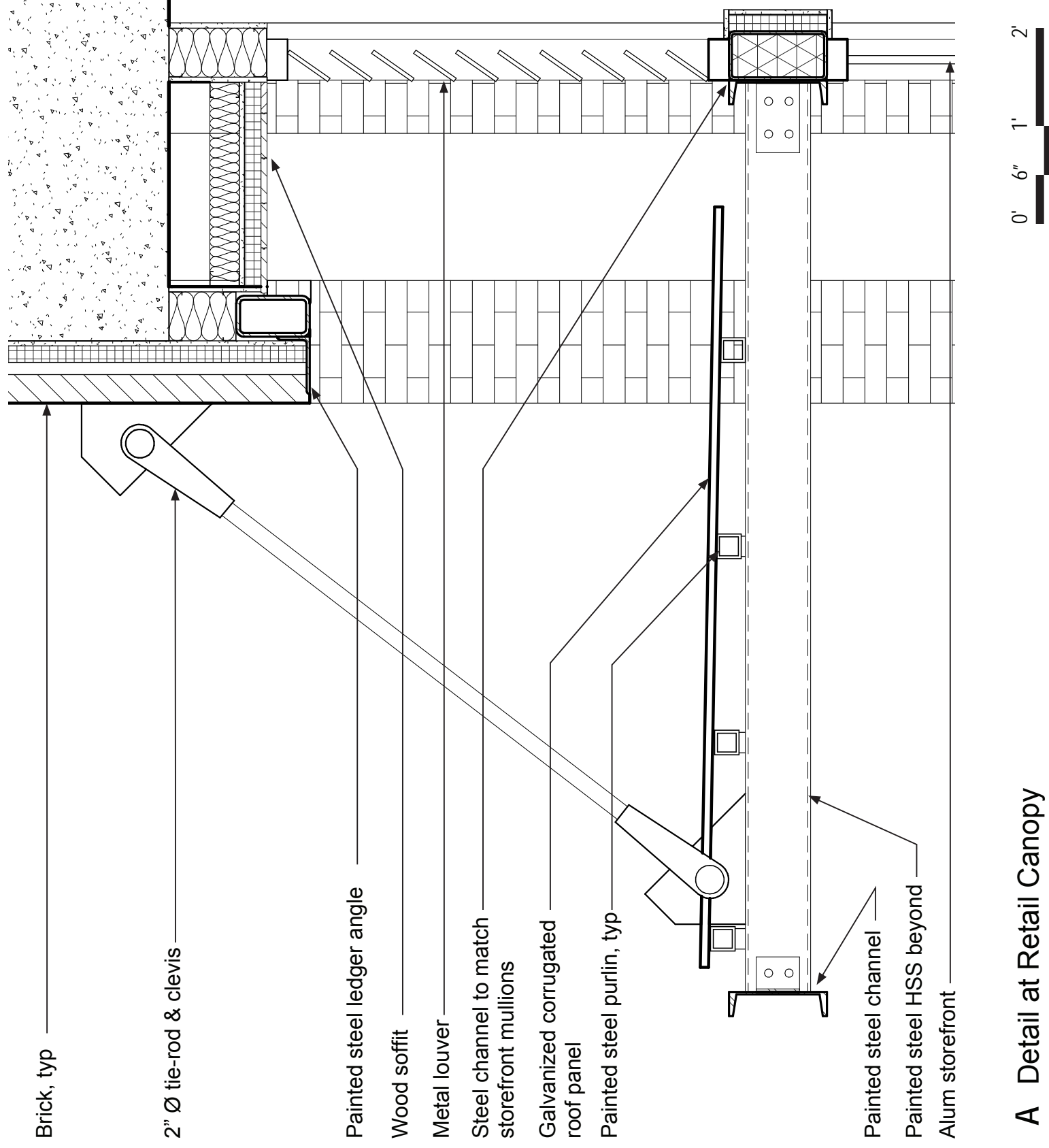

A Detail at Retail Canopy

# 13th Avenue Building Details

## Courtyard Dock

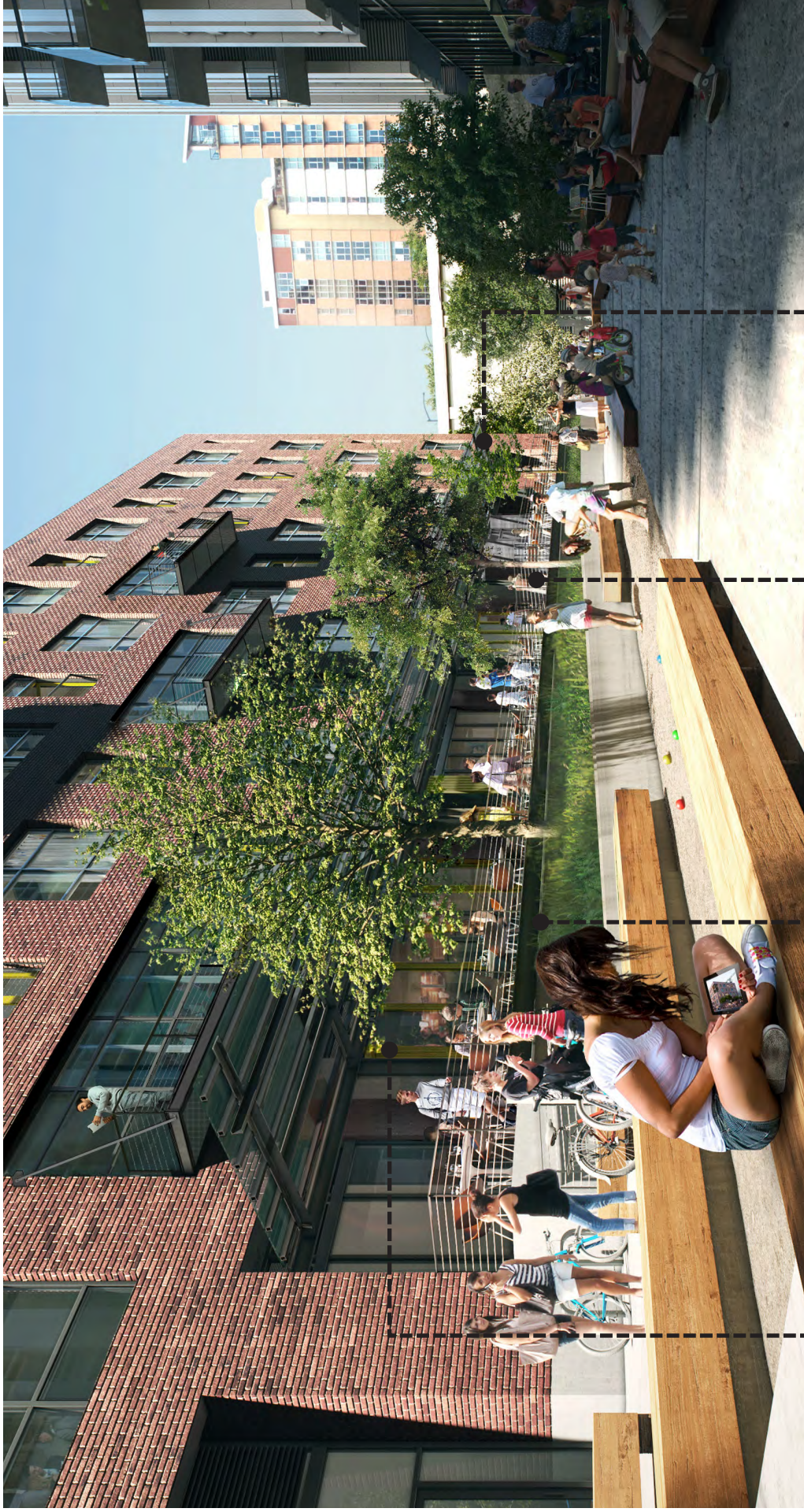

Rendering at Courtyard Dock



Folding storefront

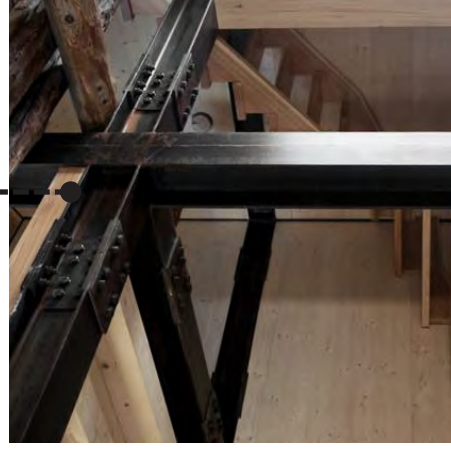

Painted steel structure



Painted steel flat-bar rails w/  
SST cables



Steel canopy w/ glass roof



# 13th Avenue Building Details

Typical West Facade

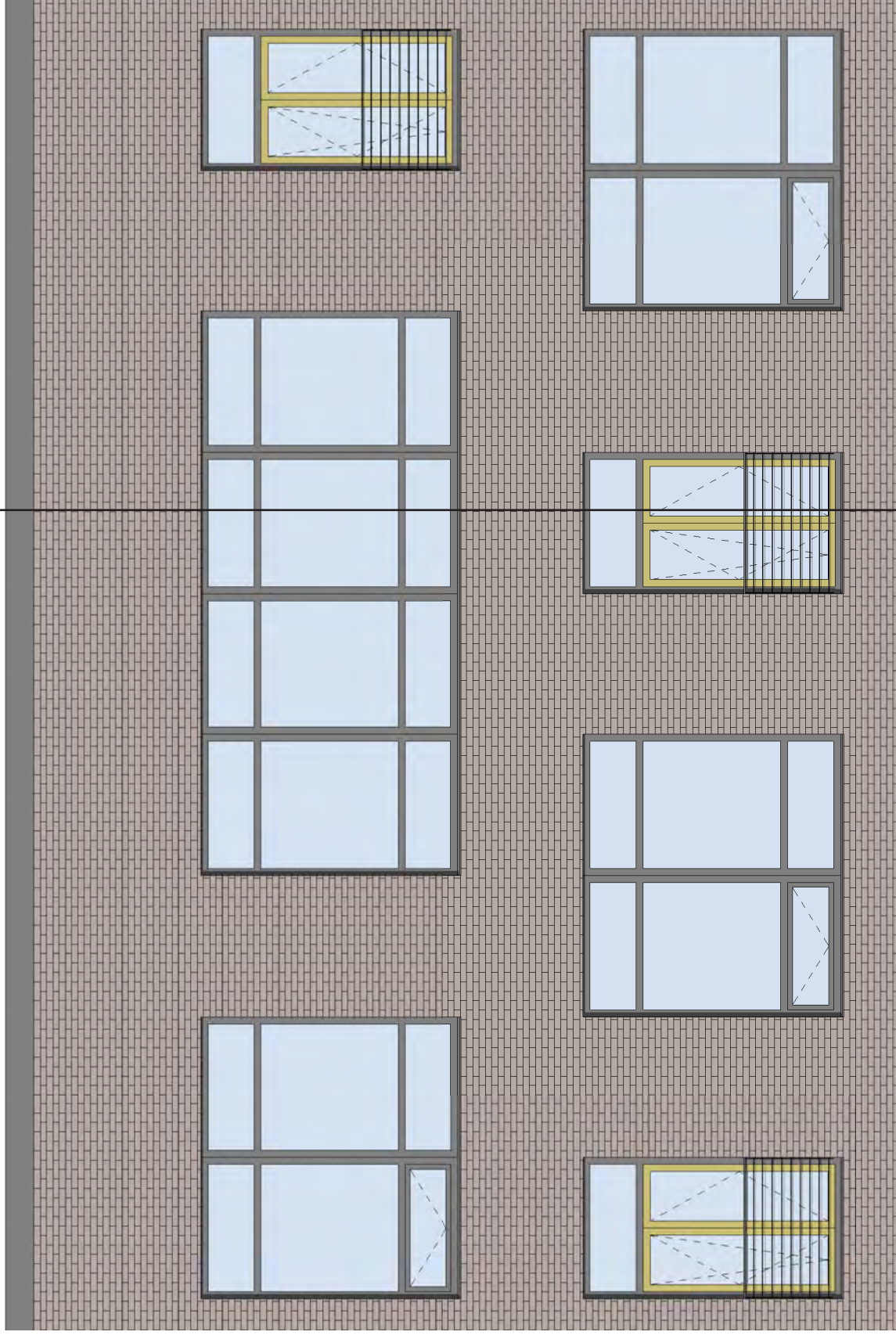

A Elevation

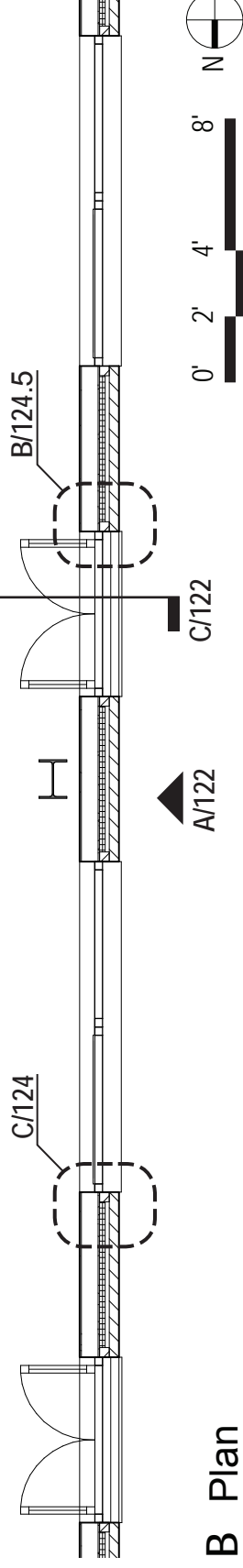

B Plan

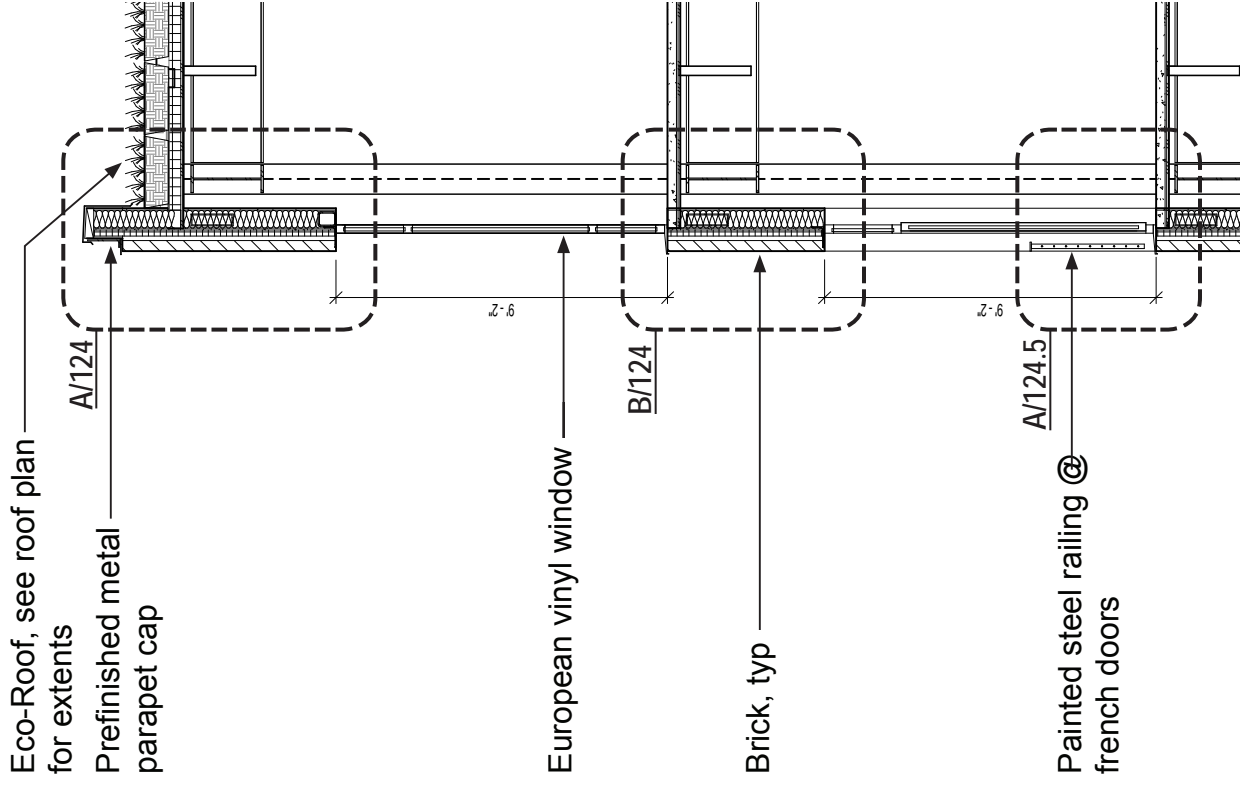

C Section

Eco-Roof, see roof plan for extents

Prefinished metal parapet cap

European vinyl window

Brick, typ

Painted steel railing @ french doors

# 13th Avenue Building Details

Typical West Facade

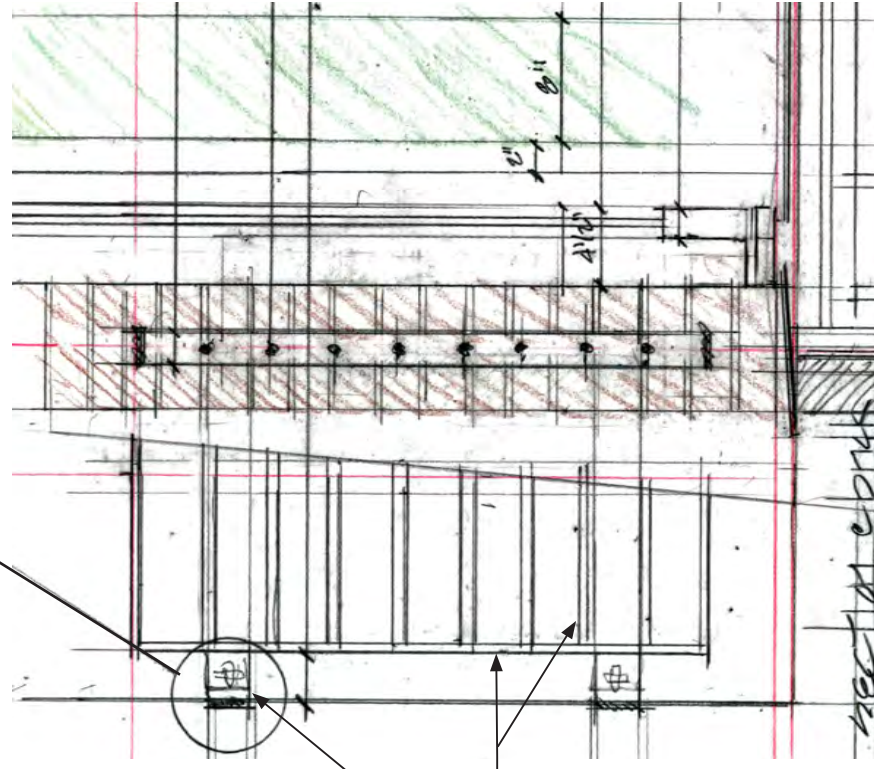
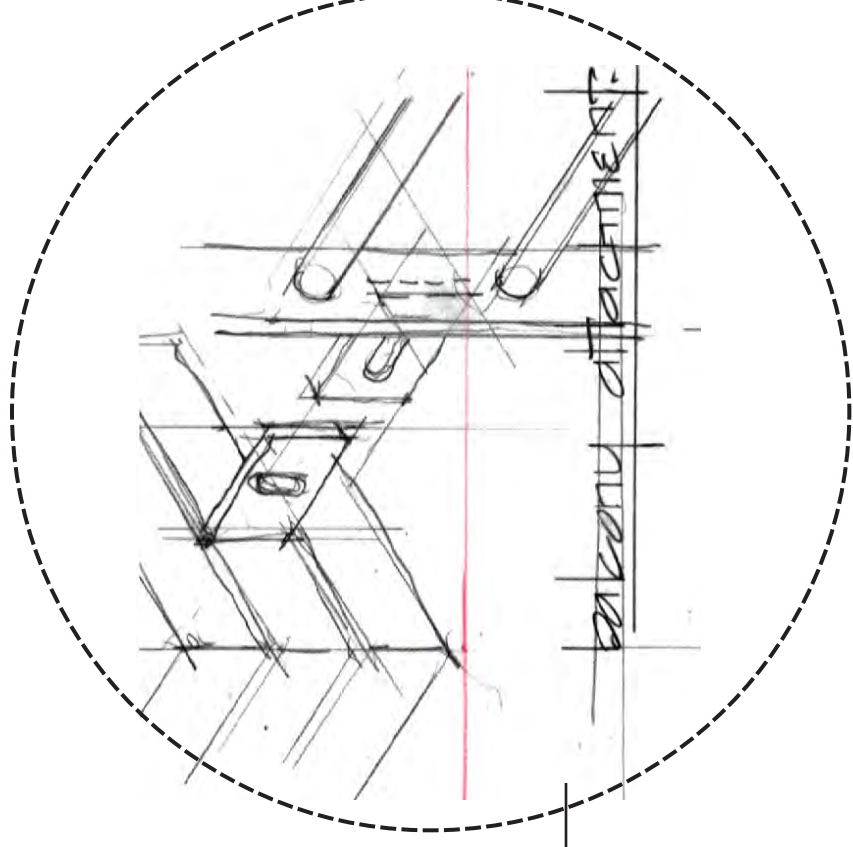

Steel tabs @ brick jamb

Painted steel flat-bar railing w/ steel rods

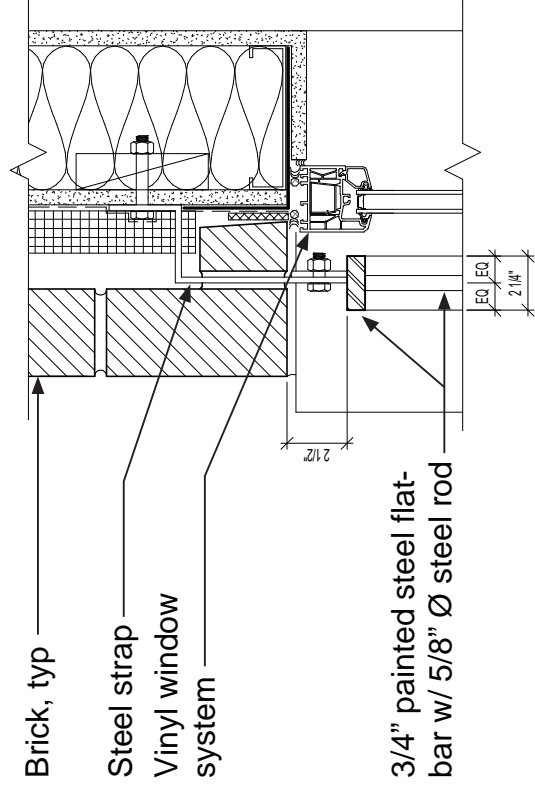

Brick, typ

Steel strap

Vinyl window system

3/4" painted steel flat-bar w/ 5/8" Ø steel rod

A Detail at French Door Railing

B Jamb Detail at Railing



# 13th Avenue Building Details

## Typical West Facade



Rendering at West Facade



Brick



Painted steel rails w/ horiz. rods



Colorful french doors



European vinyl window



# 13th Avenue Building Details

## Typical West Facade

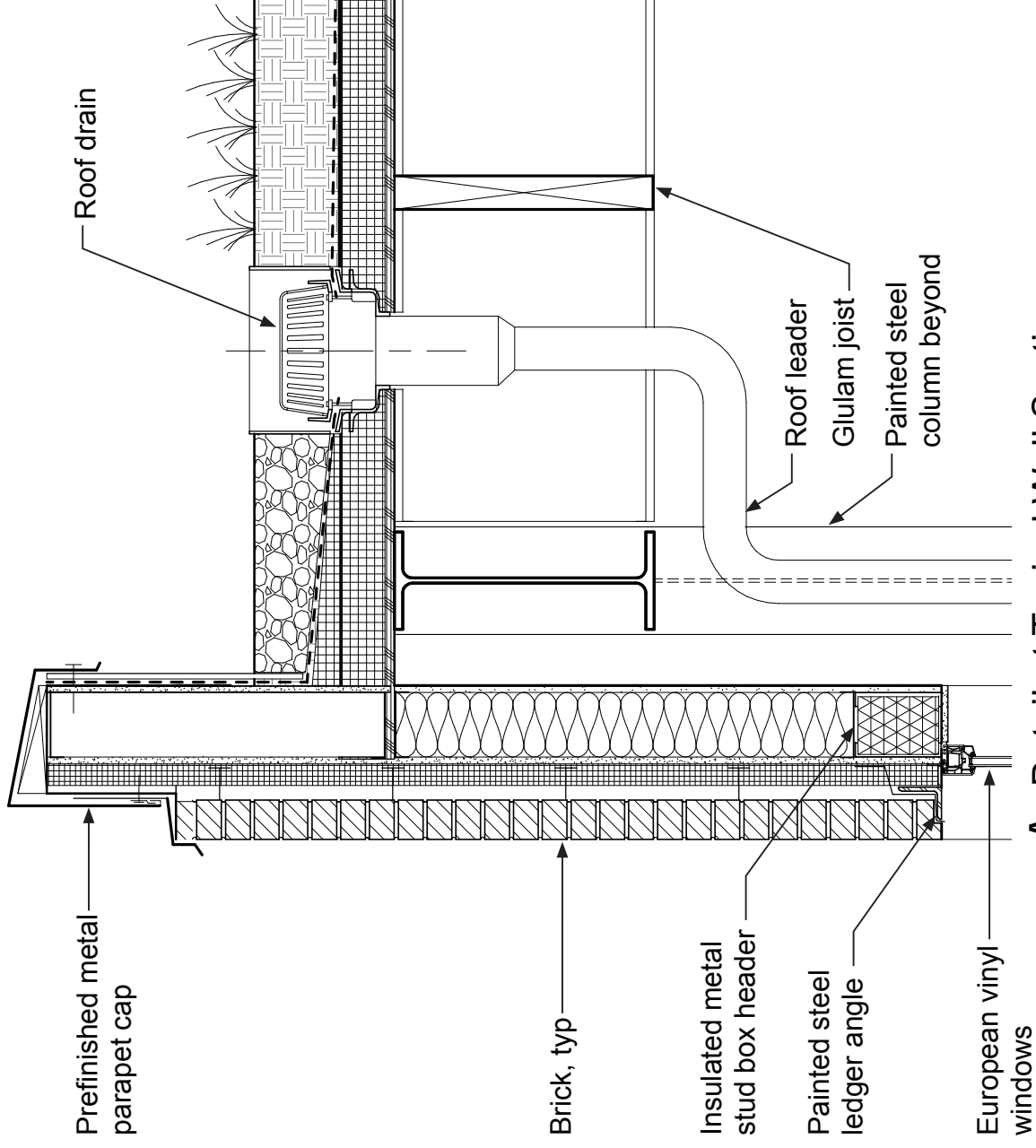

**A Detail at Typical Wall Section**

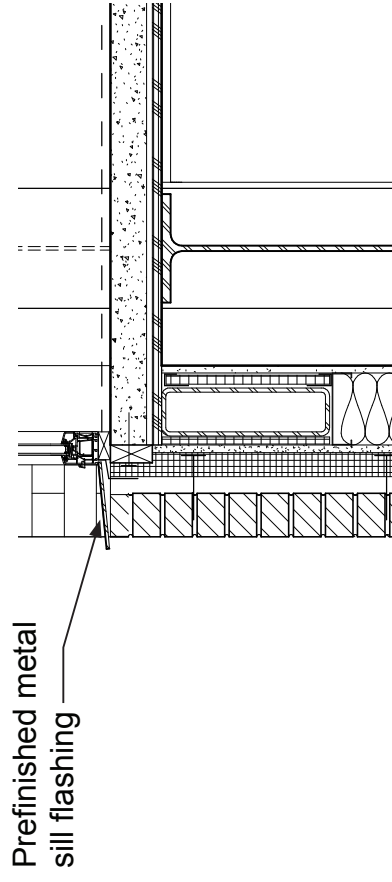

**B Detail at Typical Wall Section**

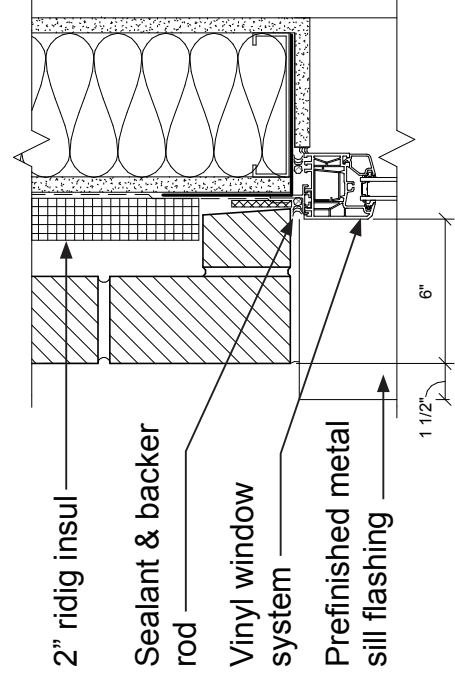

**C Jamb Detail at Window**

# 13th Avenue Building Details

Kerf Patio at Southwest Corner



A Elevation

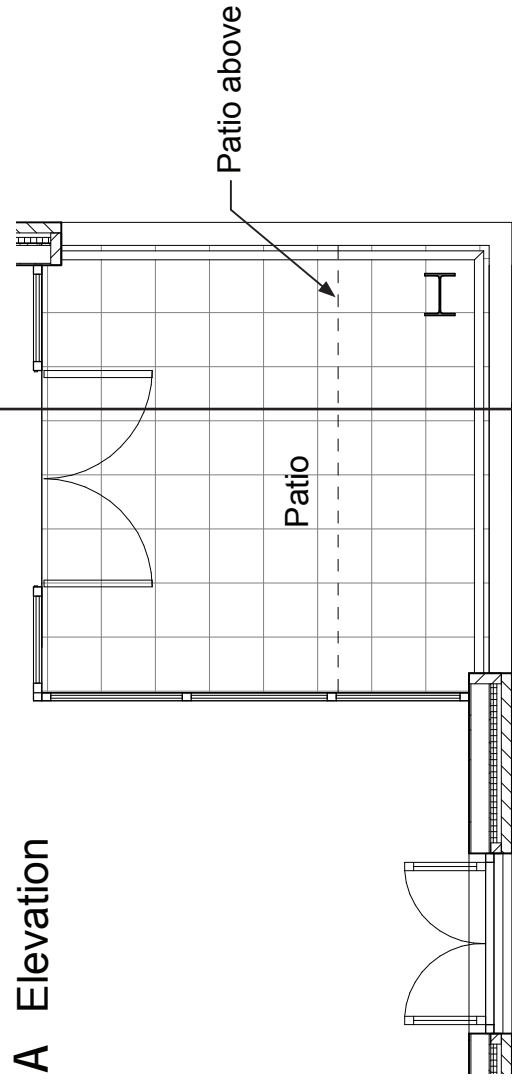

B Plan



PORTLAND BLOCK 136 | LAND USE APPLICATION LU14-230014 DZM, AD

January 22, 2015

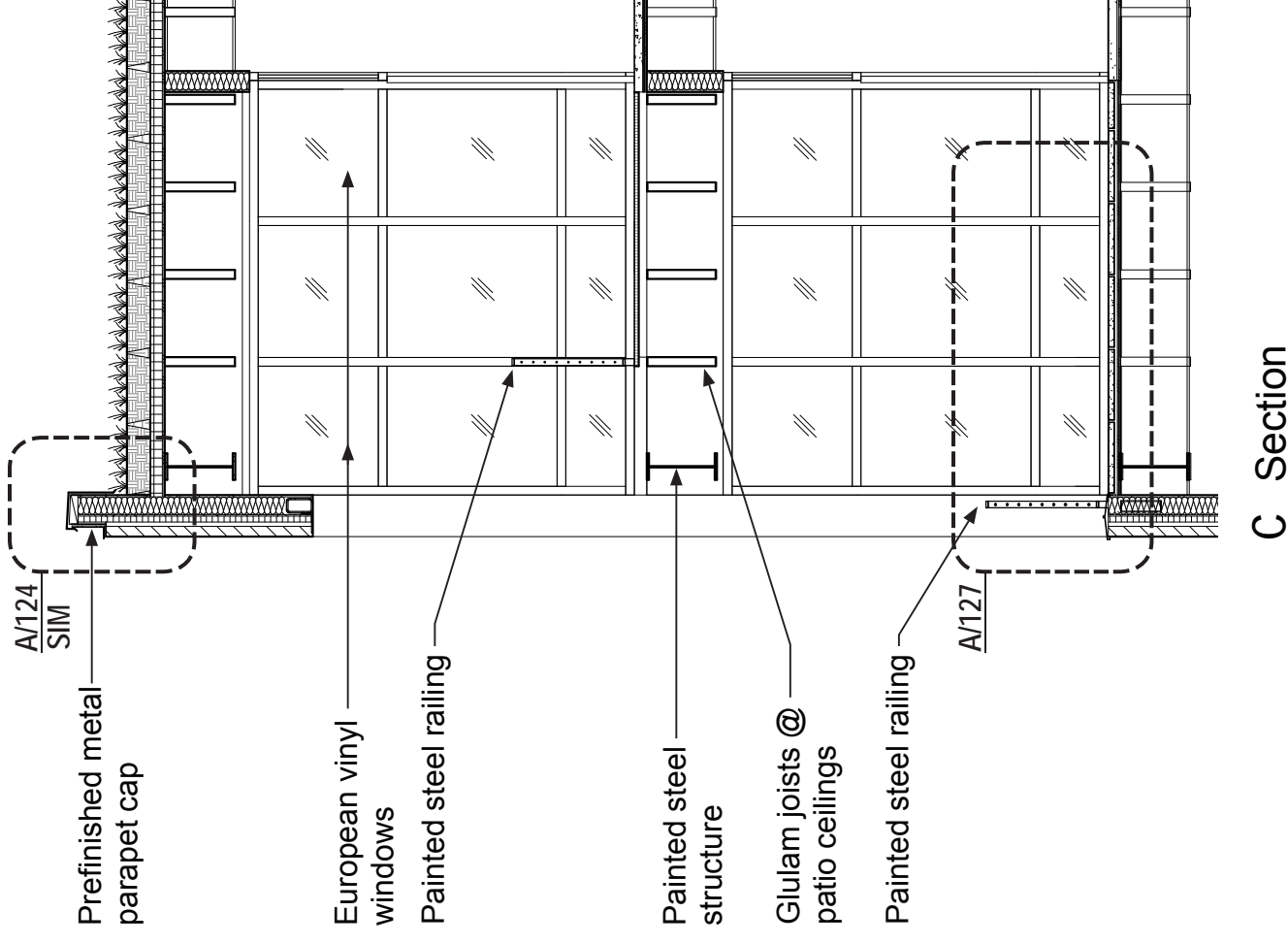

C Section

# 13th Avenue Building Details

Kerf Patio at Southwest Corner

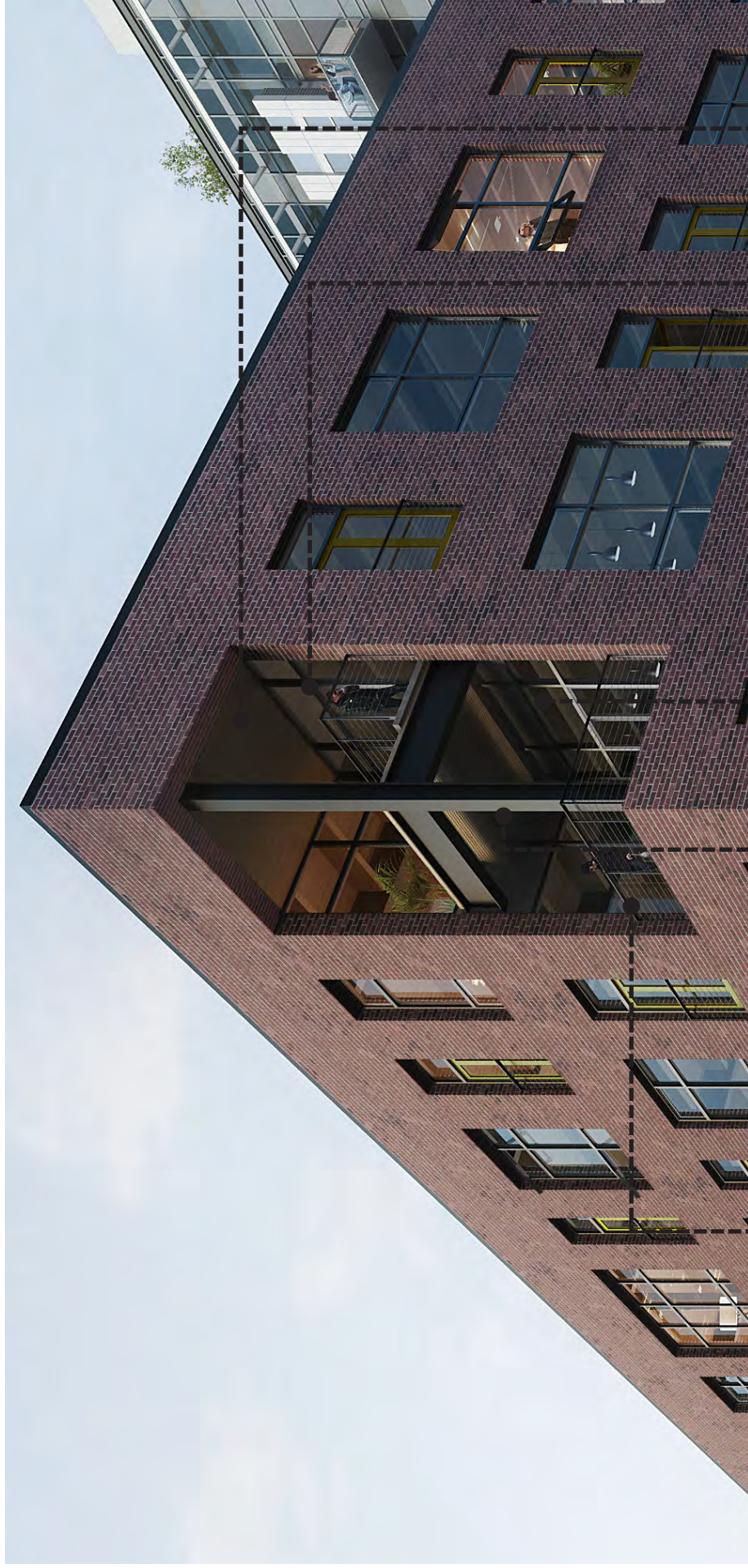

Rendering at Kerf Patio



Painted steel rails w/ horiz. rods

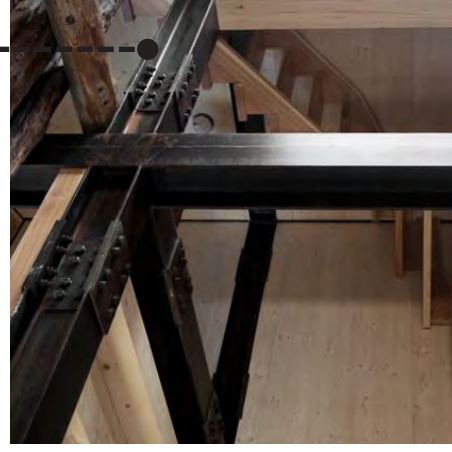

Painted steel structure



European vinyl window



Charcoal colored french doors

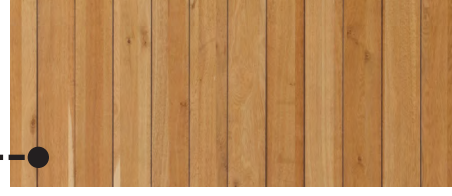

Wood soffits

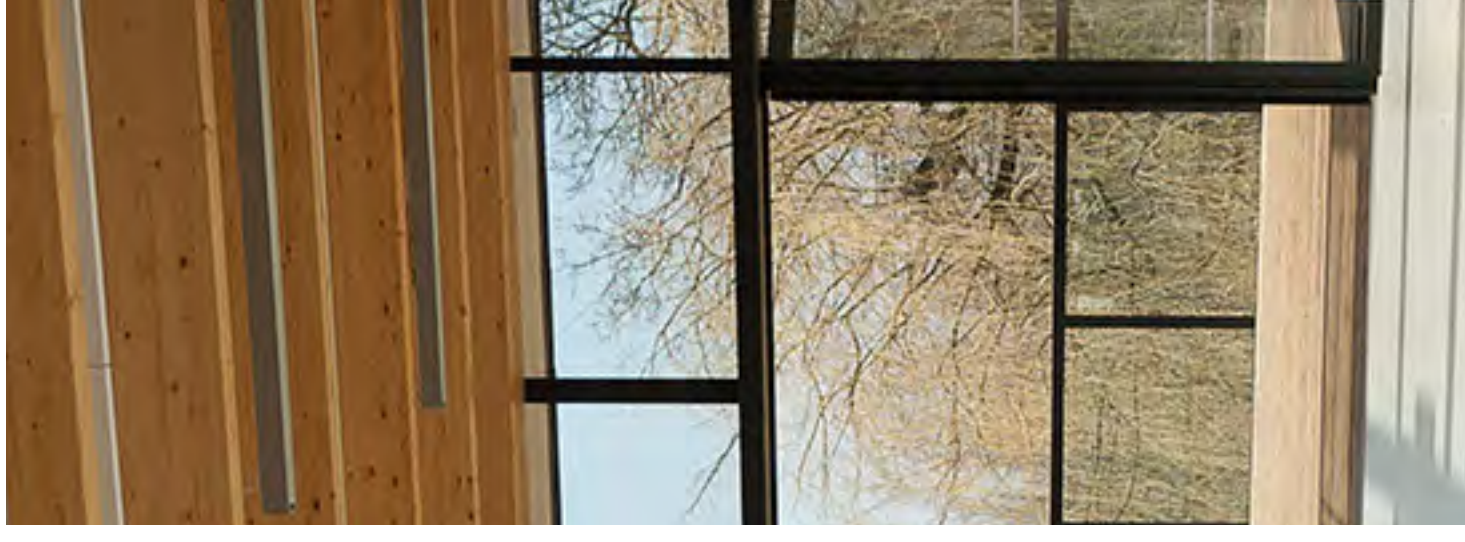

# 13th Avenue Building Details

Kerf Patio at Southwest Corner

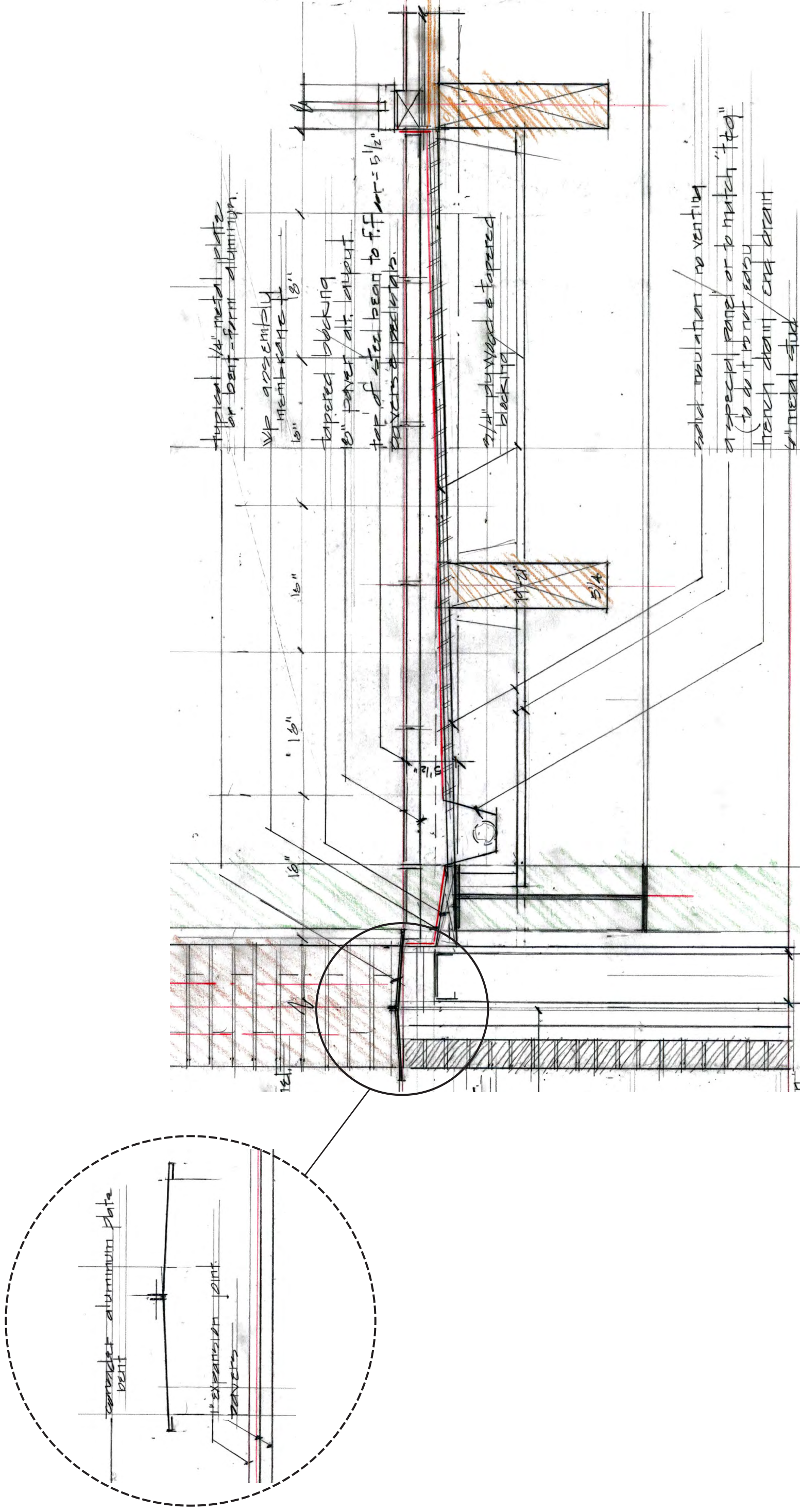

A Detail at Kerf Patio Floor



# 13th Avenue Building Details

Balcony at Courtyard

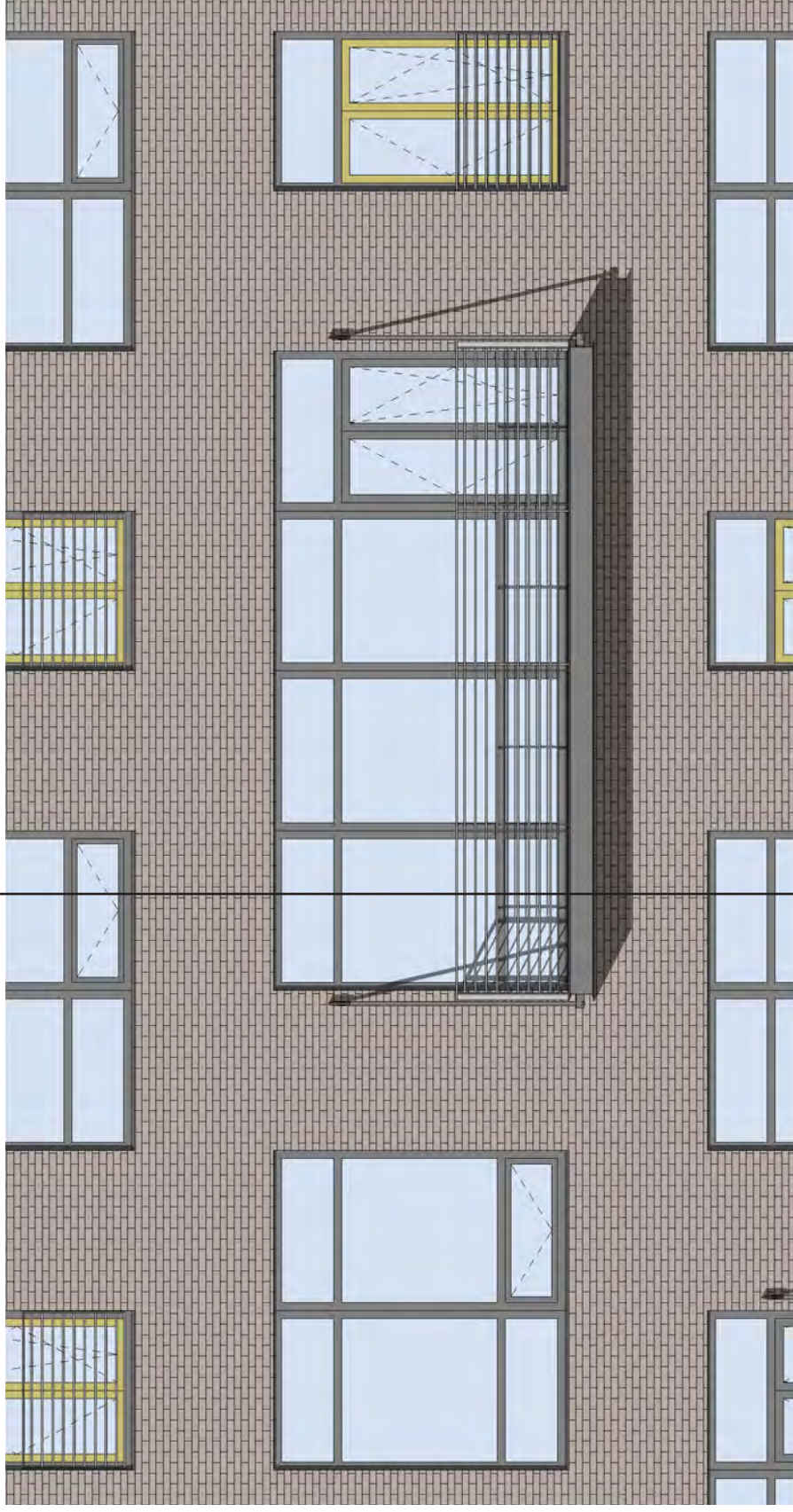

A Elevation

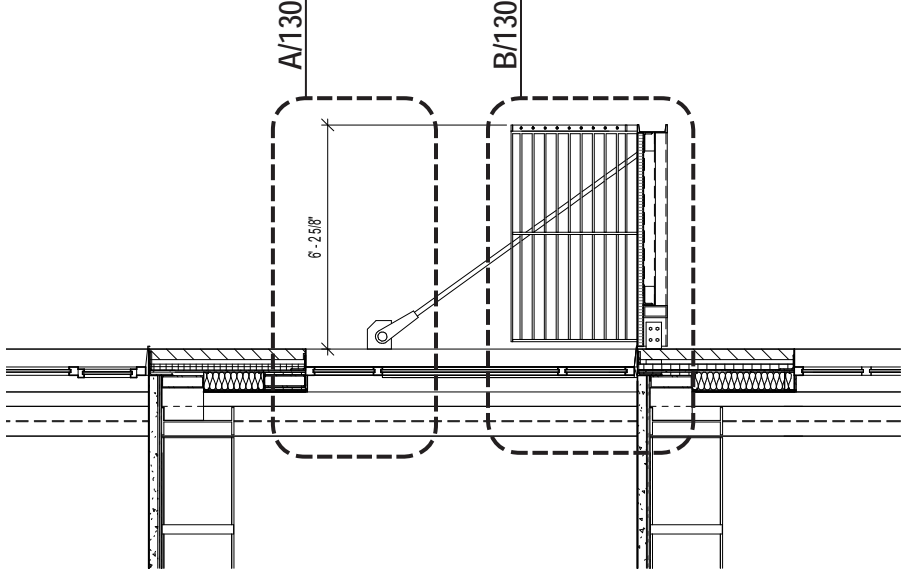

C Section

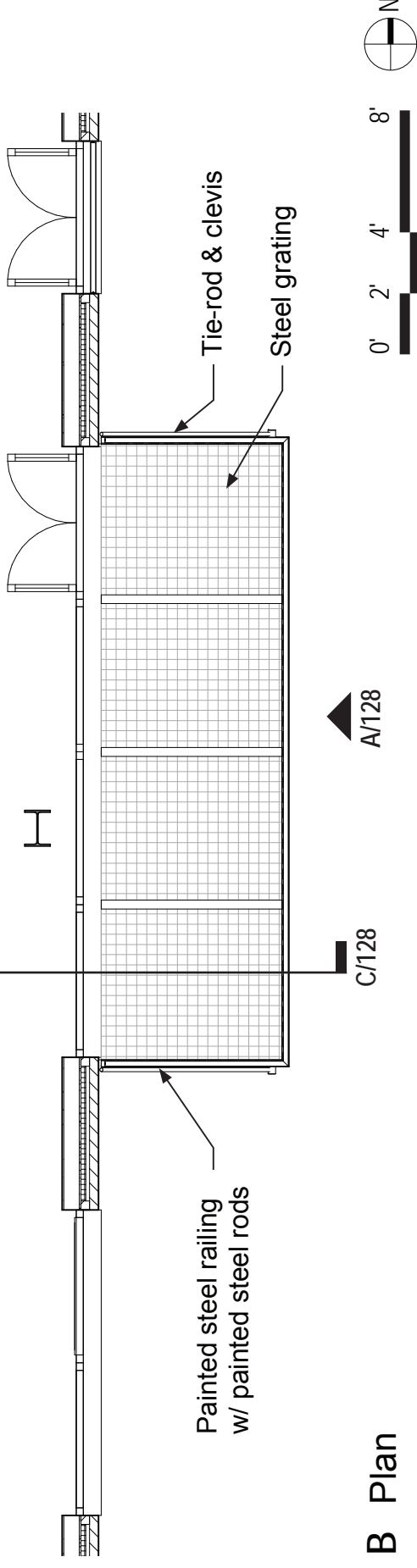

B Plan

# 13th Avenue Building Details

Balcony at Courtyard



Rendering at Courtyard

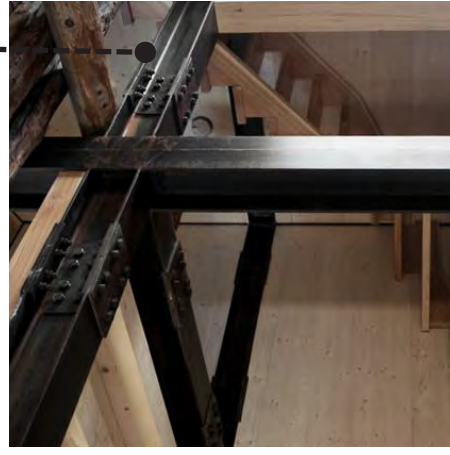

Painted steel structure



Painted steel rails w/ horiz. rods

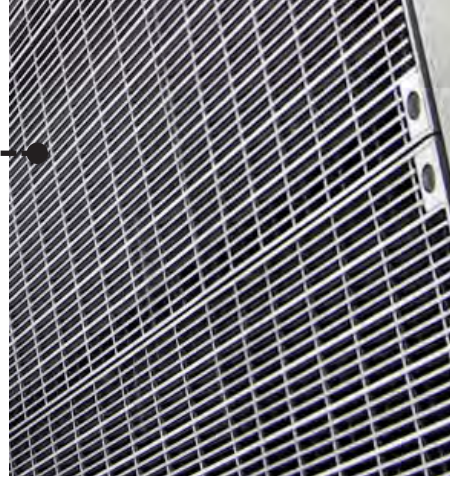

Steel grating

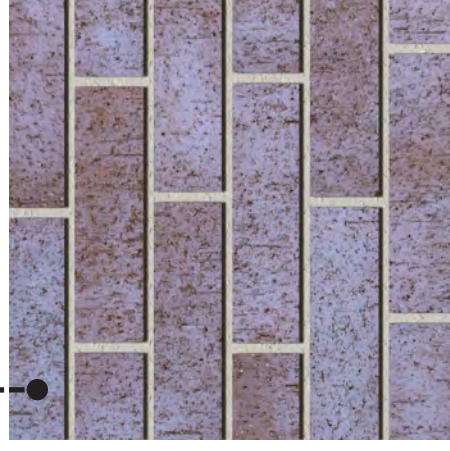

Brick

# 13th Avenue Building Details

Balcony at Courtyard

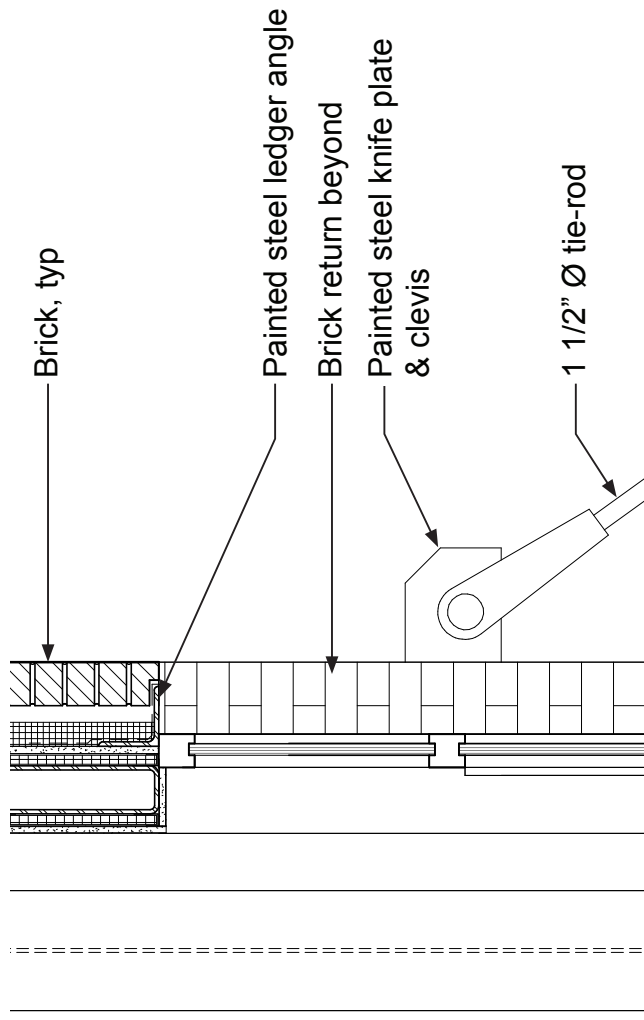

A Head at Balcony

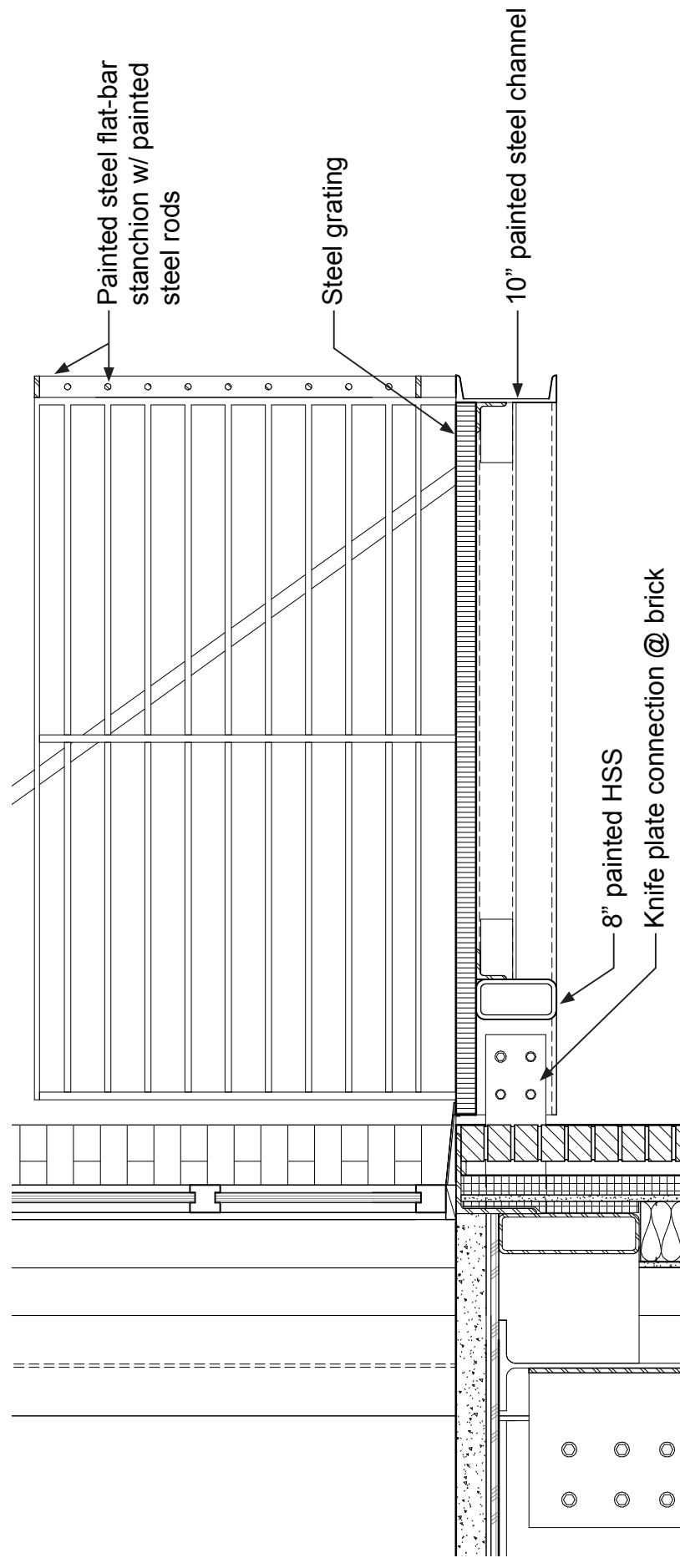

B Floor at Balcony

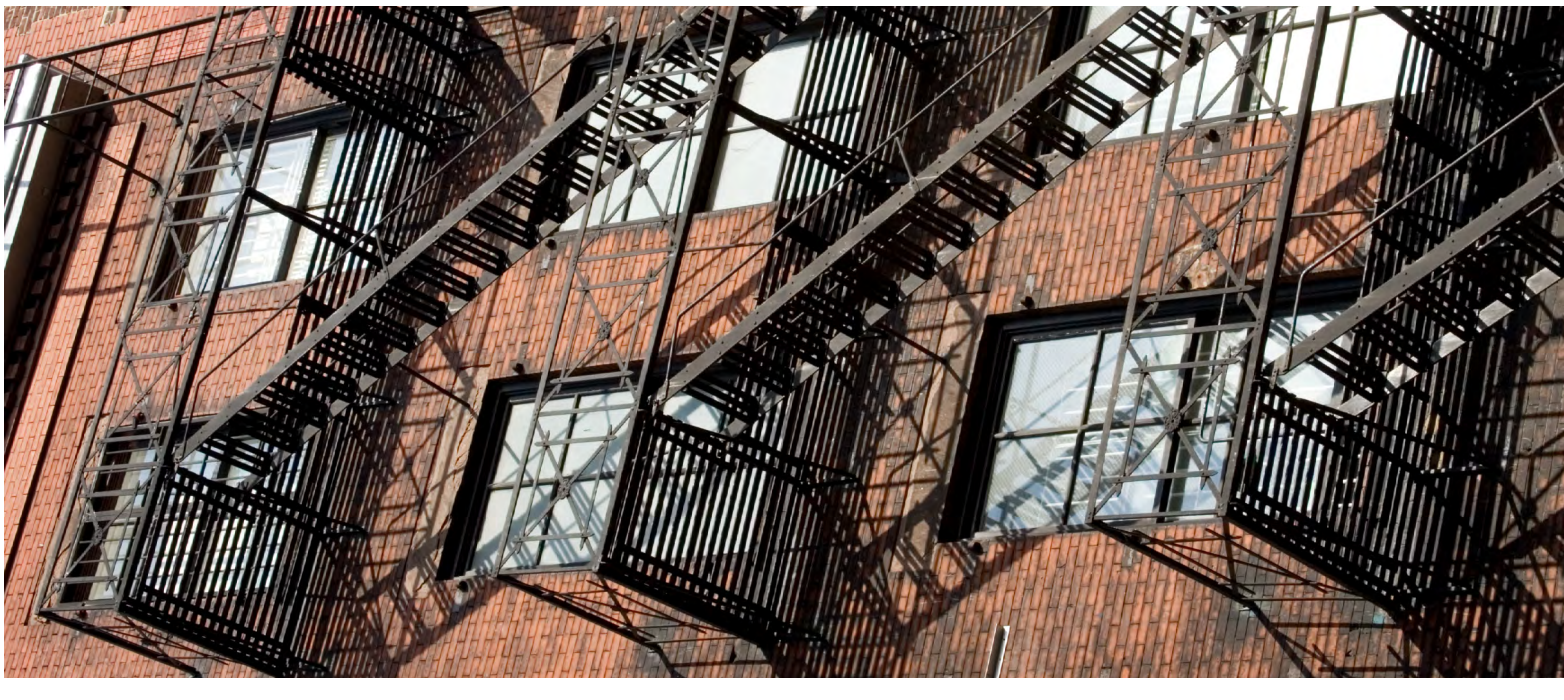

Industrial appurtenance

# 13th Avenue Building Details

## Mechanical Penthouses & Rooftop Enclosures

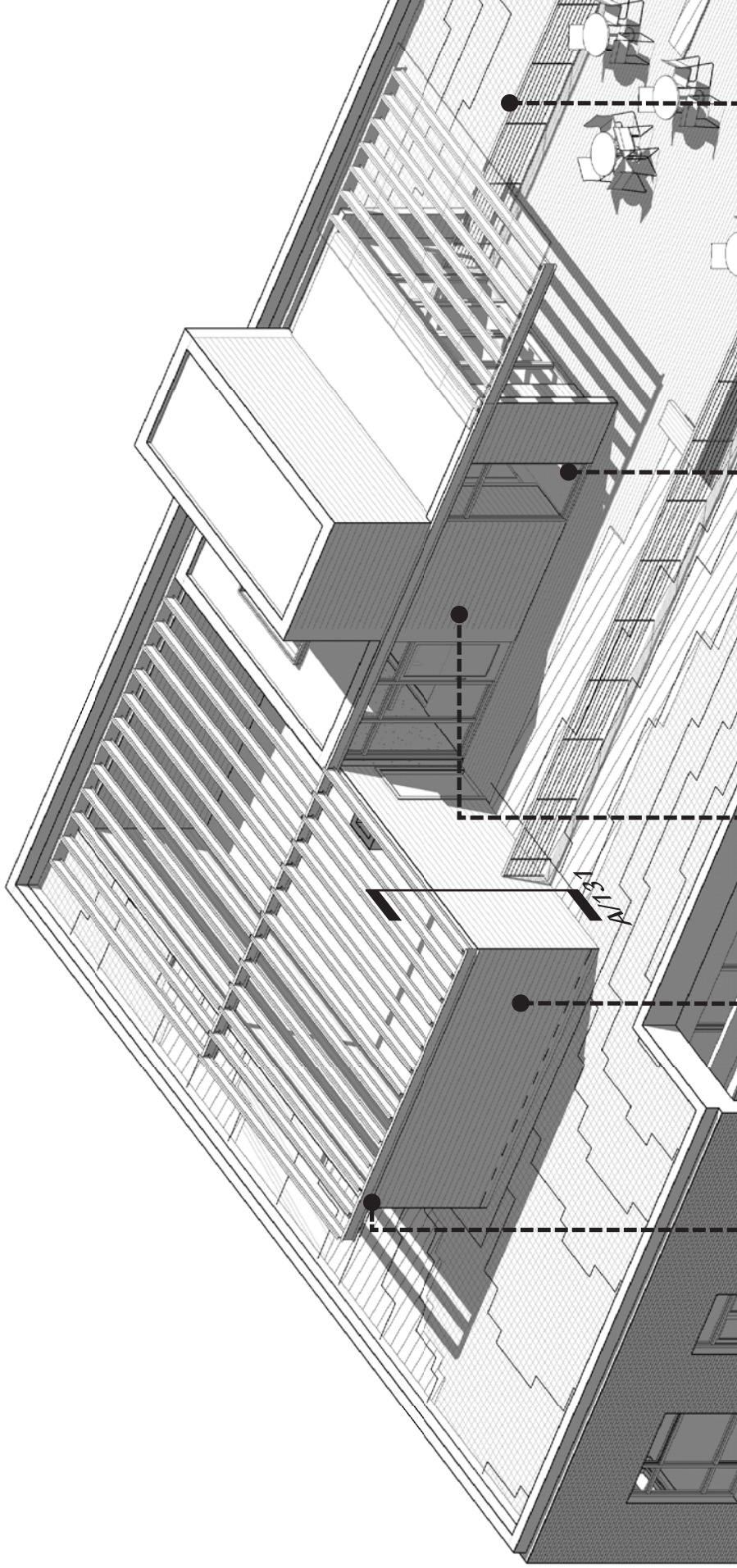

Axon View at Rooftop Penthouse



Painted steel trellis

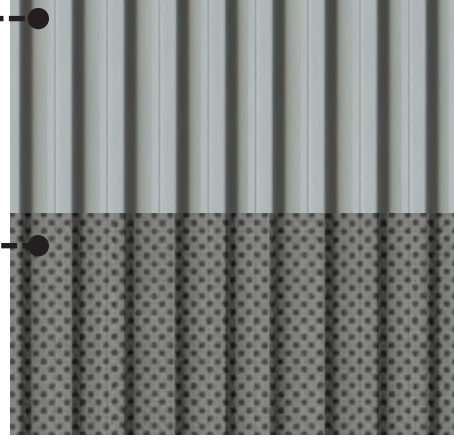

Steel Corrugated Panel



Storefront



Painted steel flat-bar rails w/ SST cables

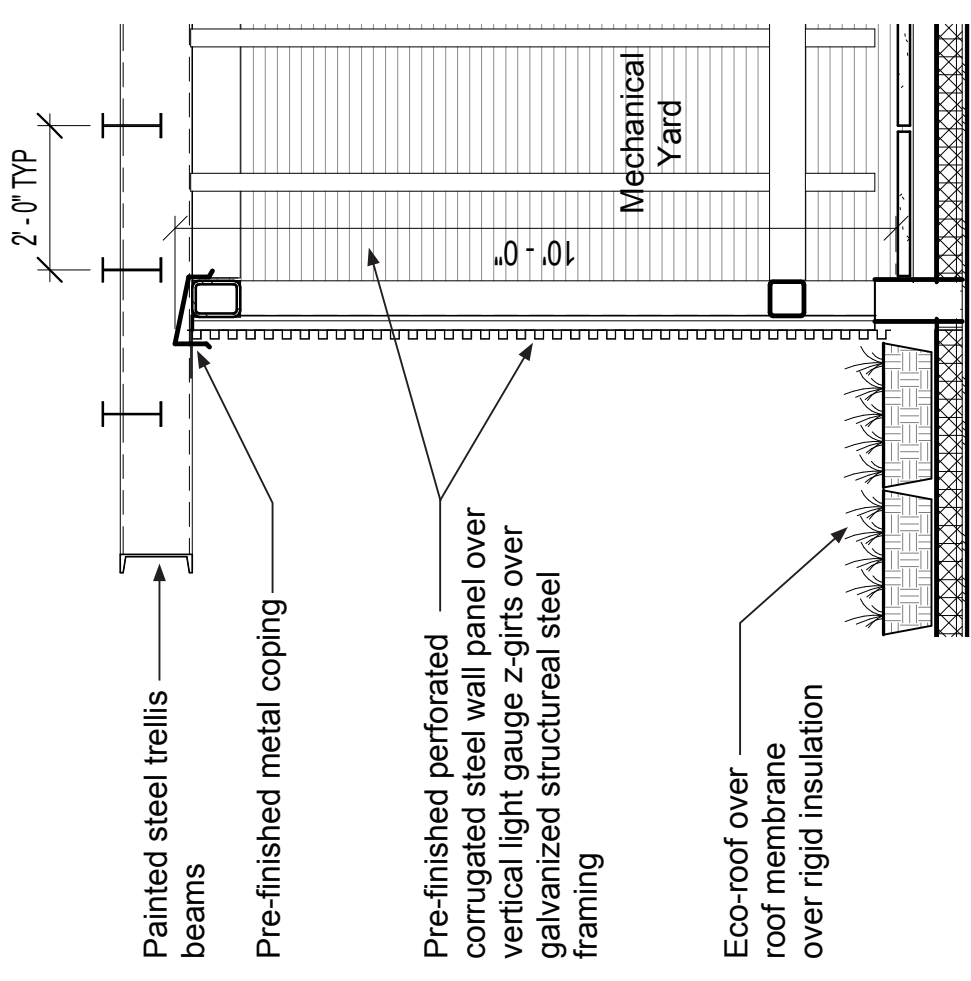

A Section at Mechanical Screen



# 13th Ave Building Roof Terrace

Concept

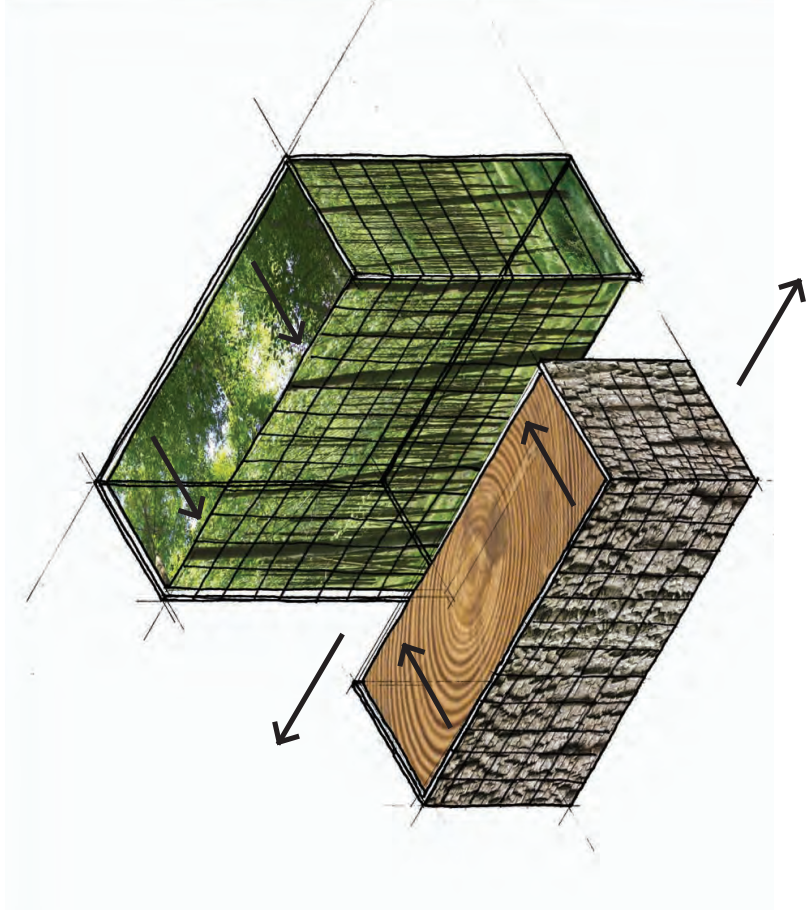

# 13th Ave Building Roof Terrace

## Plan



- 1 Elevator Lobby  
Flush with level of terrace wood pavers
- 2 Stair Access
- 3 Hardwood Bench  
Built-in bench of tropical hardwood
- 4 Stainless Steel Cable Rail  
Setback from paving in particular areas to blend between paving and planting.
- 5 Seating Area with movable tables and chairs
- 6 Maintenance Path  
Access route of crushed rock or cinder; min. 1'-0" wide, incorporated into roof pattern
- 7 Trellis Overhang
- 8 Tree Planter, 1 of 3  
Large scale precast concrete planter with min. depth of 24", planted with small-medium specimen trees to create areas of shade and divide spaces within terrace.
- 9 Mechanical Space

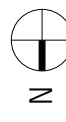

# 13th Ave Building Roof Terrace

View from 12th Ave Building



# 13th Ave Building Roof Terrace

## Plant Palette

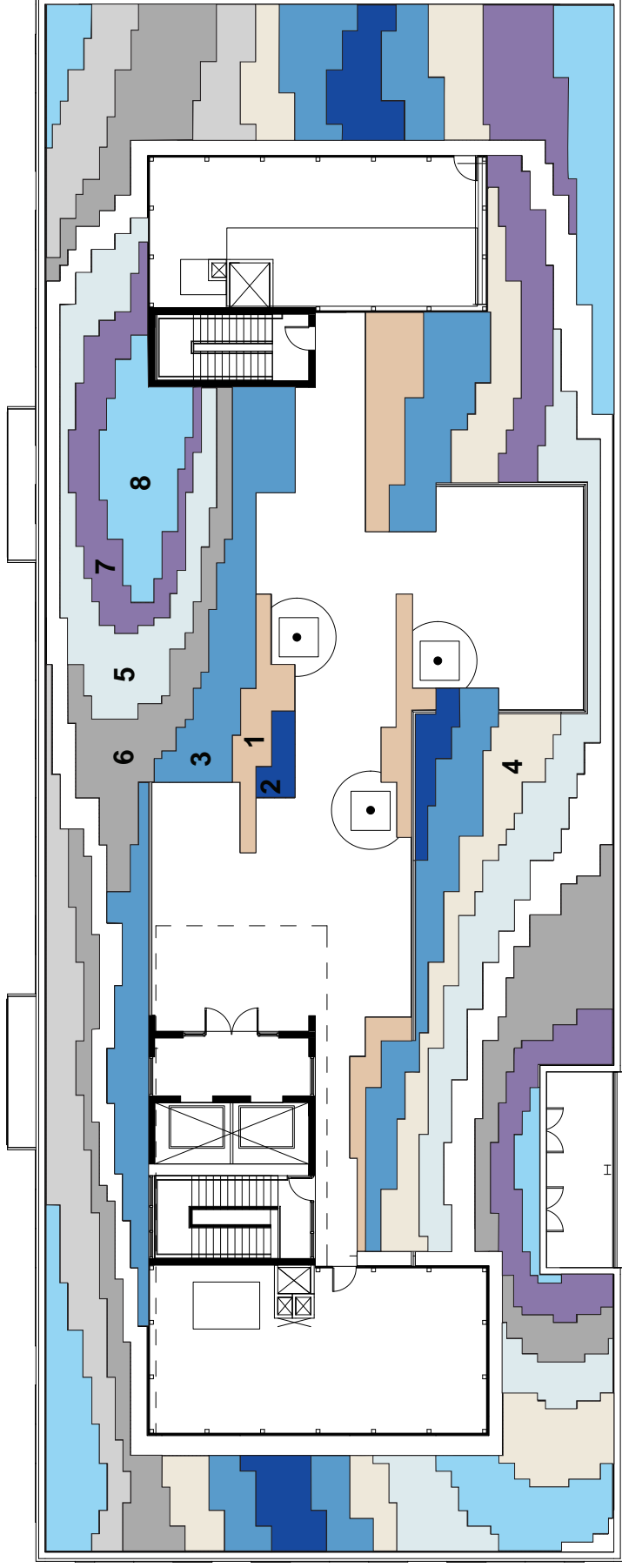

BOTANICAL NAME      COMMON NAME      SIZE      ROOT CONDITION      ON-CENTER SPACING

TREE	PERSIAN IRONWOOD	3" CAL	CONTAINER	AS SHOWN
Parrotia persica				

GREEN ROOF	COMMON NAME	ROOT CONDITION	CONTAINER	AS SHOWN
1	Mexican Beach Pebbles			
2	Sempervivum 'Lavendar & Old Lace'	Hen and Chicks		
3	Sedum makinoi 'Ogon'	Yellow Flowered Sedum		
	Achillea millefolium	Yarrow		
4	Thymus vulgaris	Thyme		
	Allium schoenoprasum 'Rising Star'	Flowering Onion		
5	Sedum spurium 'Green Mantle'	White Flowered Sedum		
6	Sedum forsterianum 'Antique Grill'	Yellow Flowered Sedum		
	Pennisetum alopecuroides viridescens	Fountain Grass		
7	Rudbeckia hirta	Black-eyed Susan		
8	Perovskia superba	Russian Sage		



Mexican Beach Pebbles



Lavender Flowered Hen and Chicks  
Sempervivum 'Lavendar & Old Lace'



Yellow Flowered Sedum  
Sedum forsterianum 'Antique Grill'



Thyme Thymus vulgaris



Yellow Flowered Sedum  
Sedum makinoi 'Ogon'



White Flowered Sedum  
Sedum spurium 'Green Mantle'



Black Eyed Susan Rudbeckia hirta



Fountain Grass Pennisetum alopecuroides viridescens



Russian Sage Perovskia superba



# 13th Ave Building Roof Terrace

## Green Roof Depth Diagram and Section

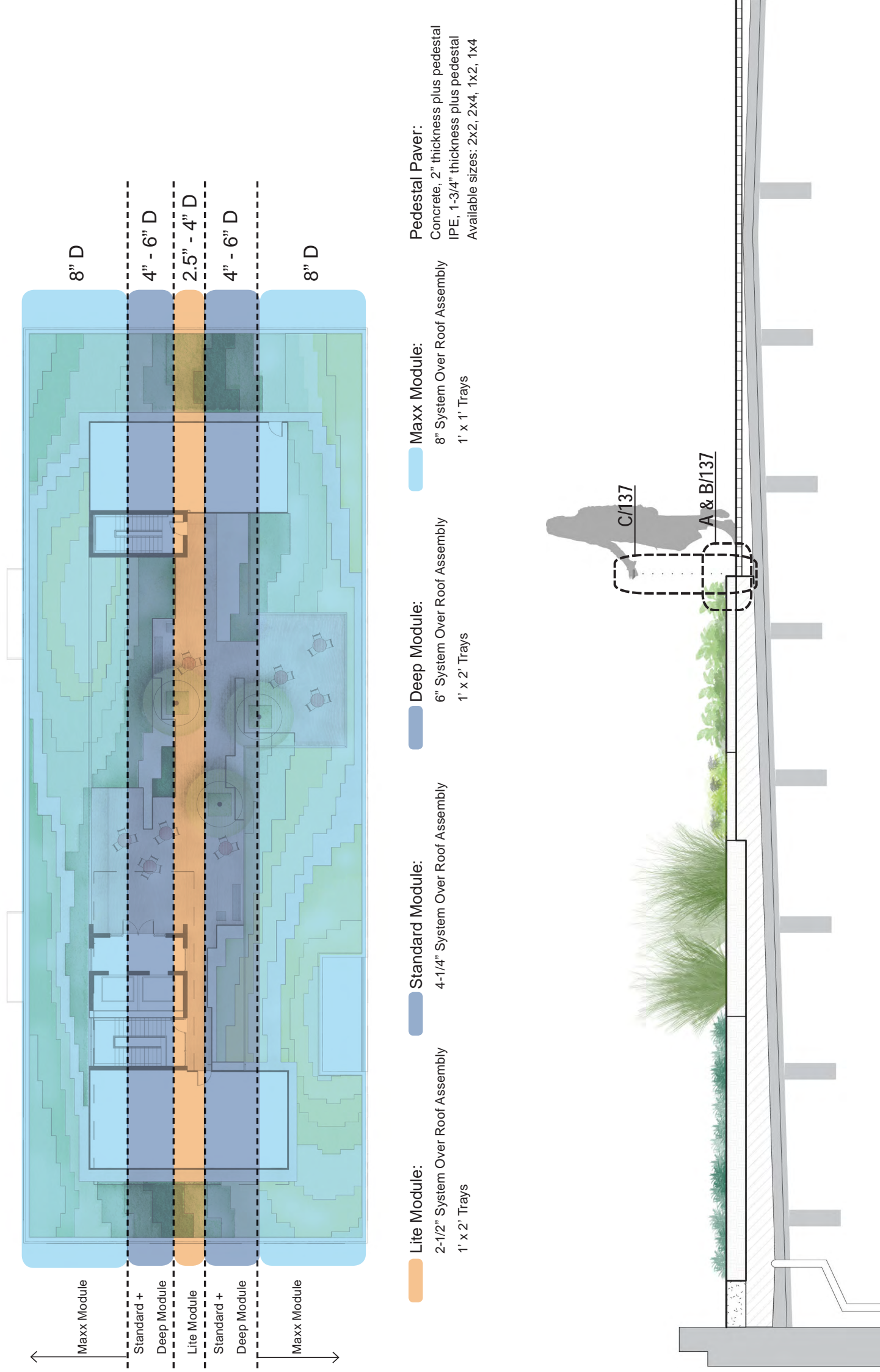

Green Roof Section

0' 2' 4' 8'

# 13th Ave Building Roof Terrace

## Details

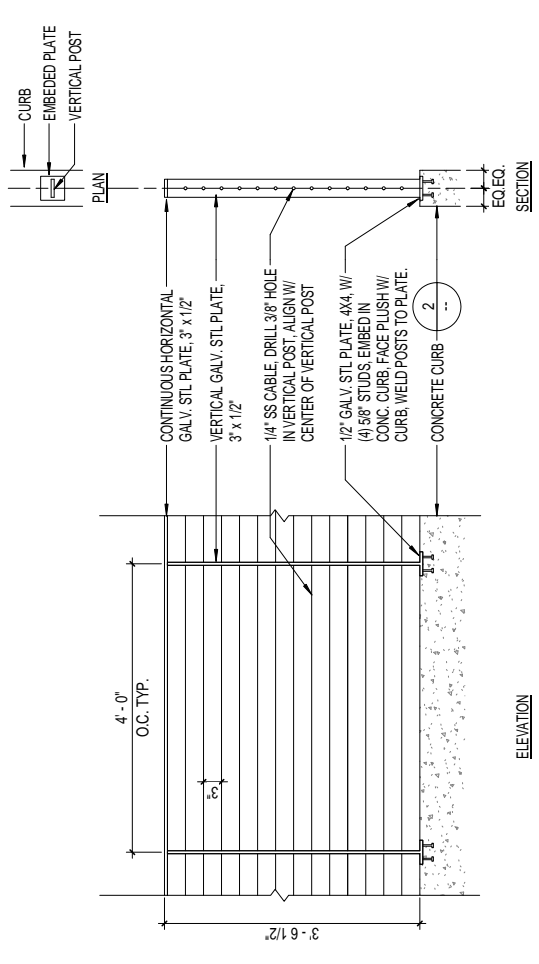

**C Roof Terrace Guardrail**  
 0' 6" 1' 2'

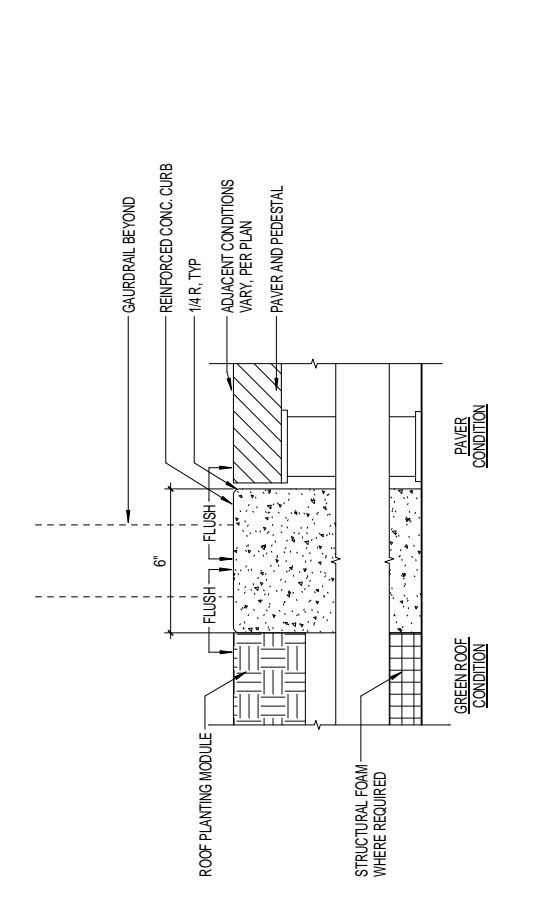

**B Concrete Curb at Roof Terrace**  
 0' 6" 1' 2'

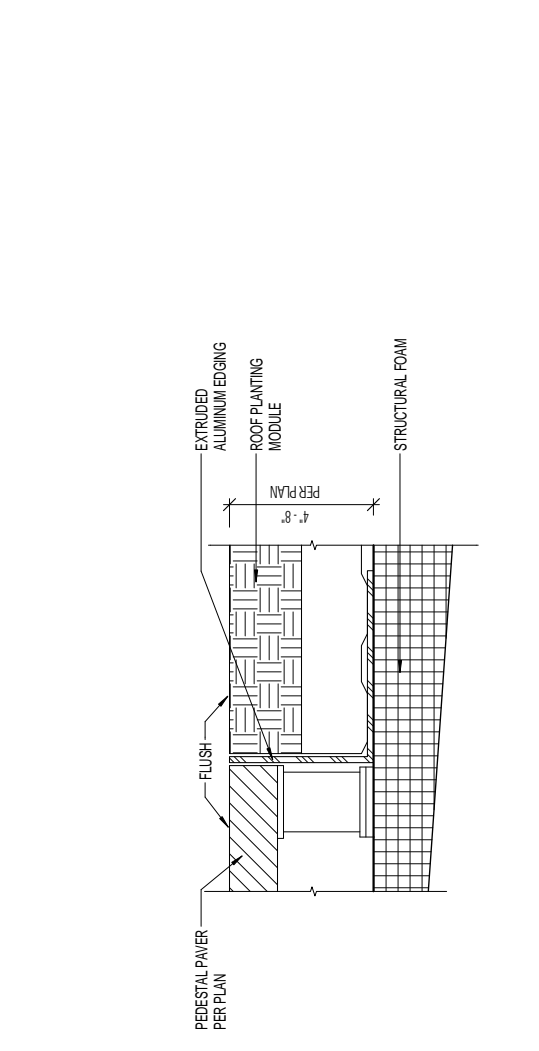

**A Green Roof Edge at Paver**  
 0' 6" 1' 2'

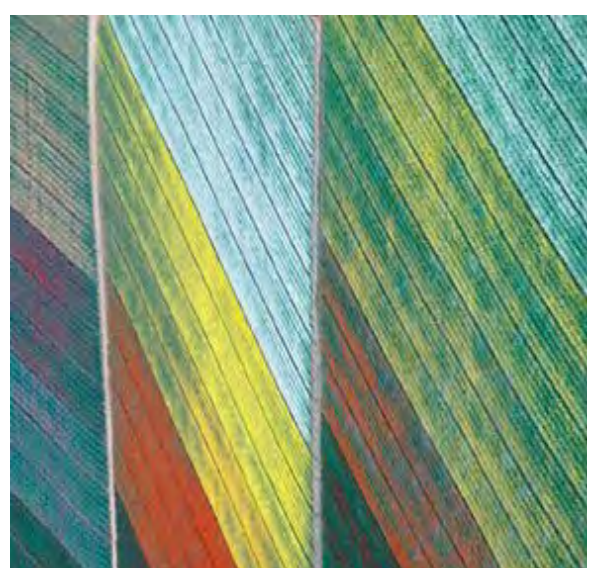

Graphic Green Roof Pattern

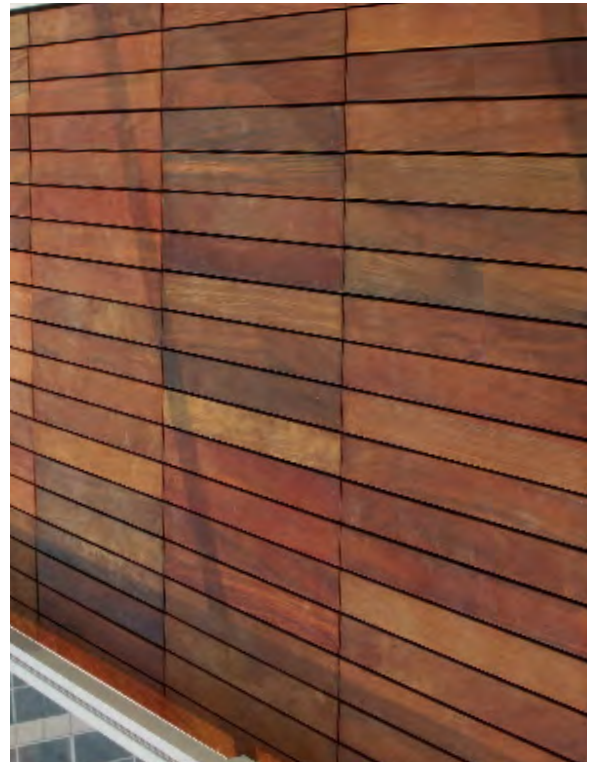

Modular Ipe Pavers



Concrete Benches  
 Landscape Forms, Socrates Bench, 95" L and 24" L



Concrete Planters  
 Greenform, Delta Square 39" W x 39" L x 24" D

# Block 136

## Appendix



# Appendix A - Miscellaneous Plans

## Site Utility Feasibility Plan

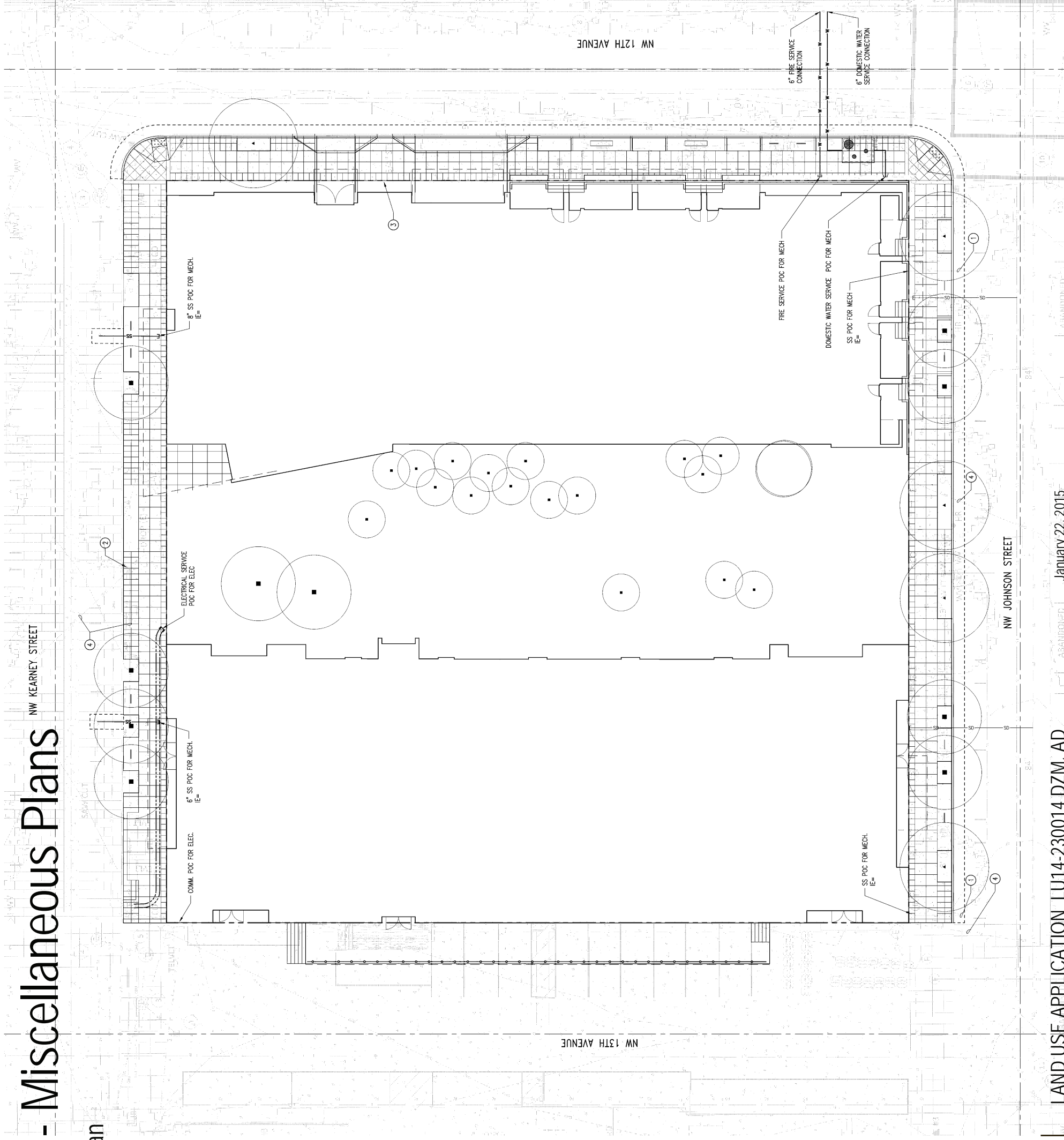

### CONSTRUCTION NOTES:

1. CONNECT TO EXISTING SEWER LATERAL. SLOPE AT 1/8" MIN. CONTRACTOR SHALL VERIFY STRUCTURAL INTEGRITY PRIOR TO CONSTRUCTION. SEE MECHANICAL FOR CONTINUATION.
2. COORDINATE WITH POE FOR REMOVAL OF EXISTING POWER POLE AND SERVICES UNDER SEPARATE PERMIT.
3. GAS CONNECTION. COORDINATE WITH GAS PROVIDER FOR METER PLACEMENT. SEE MECHANICAL PLANS FOR CONTINUATION.
4. COORDINATE WITH POE TO RELOCATE EXISTING OVERHANG UTILITY LINES.
5. TOP OF SLAB ELEVATIONS REFERENCE LOWEST GARAGE FLOOR SLAB.
6. ALL SIDE SEWER INVERT ELEVATIONS ARE APPROXIMATE. CONTRACTOR SHALL POT HOLE SIDE SEWER CONNECTIONS AND PROVIDE ACTUAL CONNECTION ELEVATIONS TO ENGINEER PRIOR TO CONSTRUCTION.

### UTILITY NOTES:

1. ALL TRENCH EXCAVATION SHALL MEET OR EXCEED ALL APPLICABLE SHORING LAWS. ALL TRENCH SAFETY SYSTEMS SHALL MEET OSHA REQUIREMENTS.
2. ADJUST GRADE MANHOLE, CATCH BASINS, AND VALVES IN PUBLIC RIGHT-OF-WAY OR EASEMENTS TO FINISHED GRADE AFTER PAVING.

### LEGEND

- SS— SANITARY SEWER LINE
- W— WATER LINE
- ◻ WATER METER VAULT
- ==== DUCT BANK

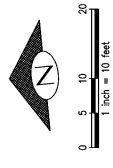

# Appendix A - Miscellaneous Plans

## Site Plan

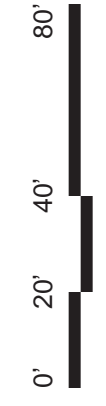
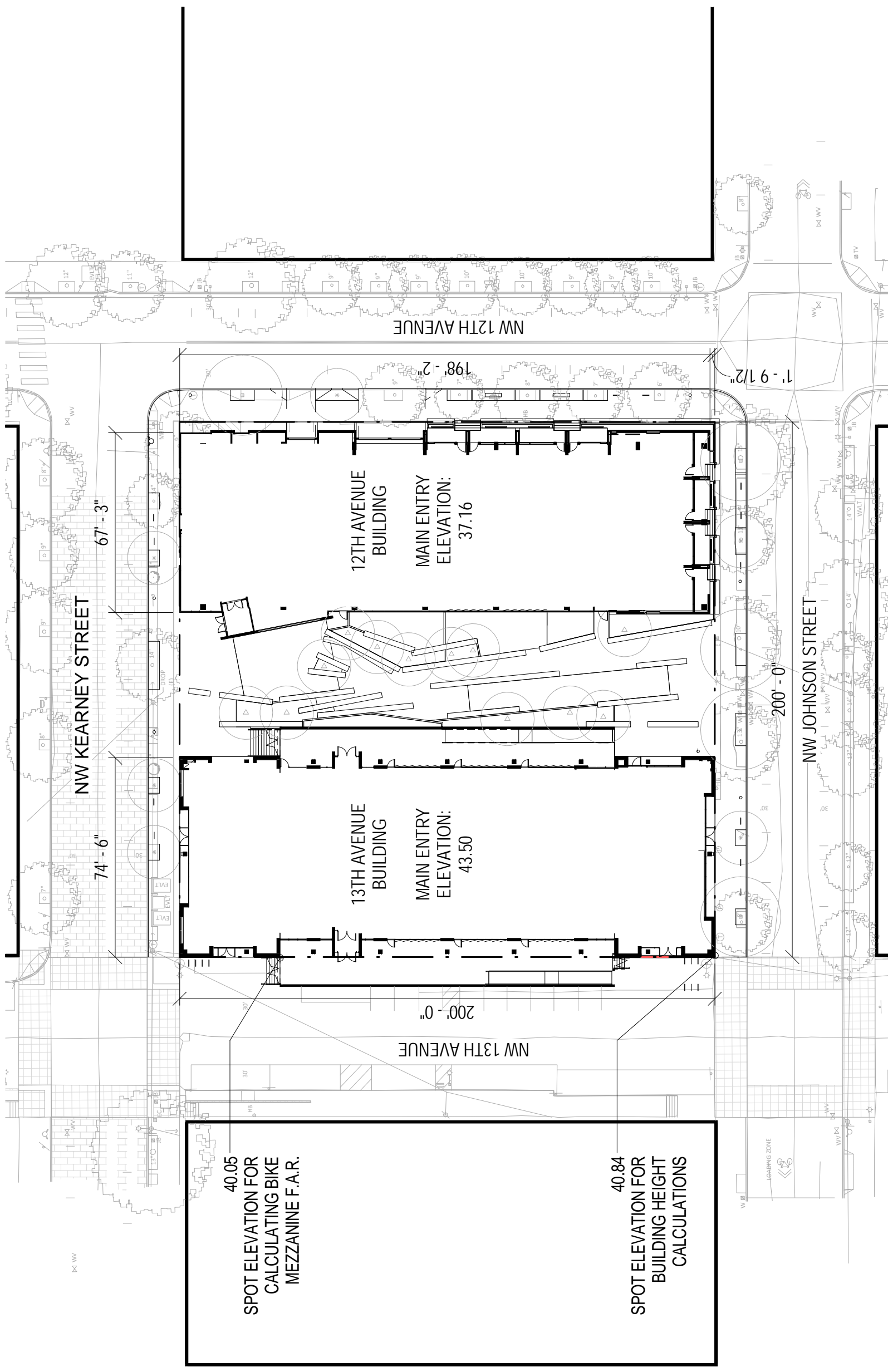

# Appendix A - Miscellaneous Plans

## Lighting - Goals

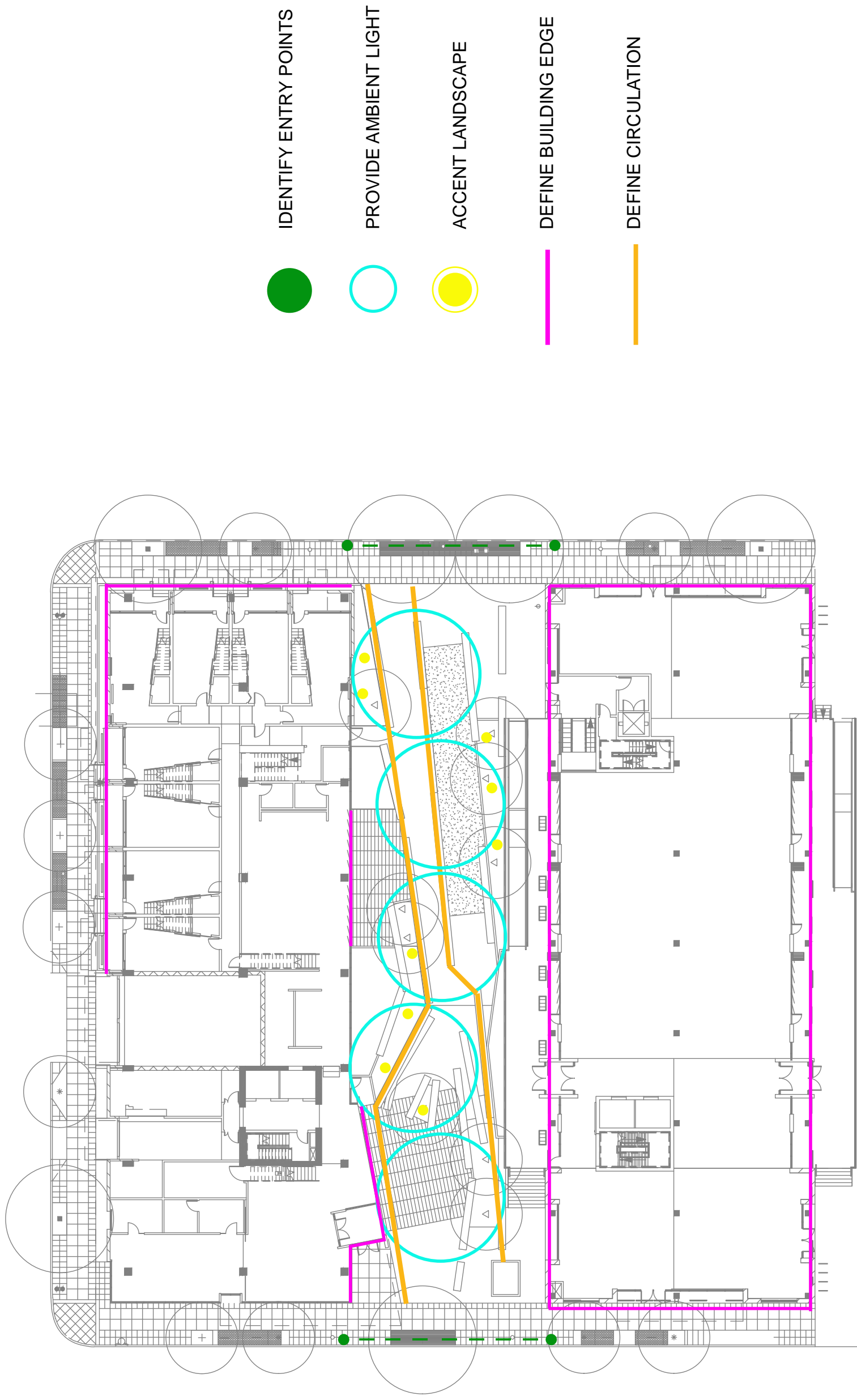

# Appendix A - Miscellaneous Plans

Lighting - Goal Precedents

DEFINE BUILDING EDGE

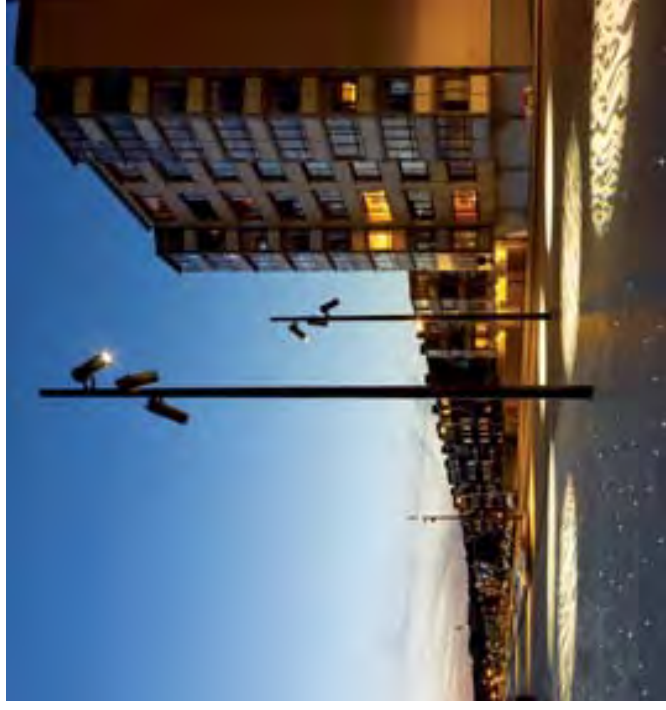

DEFINE CIRCULATION











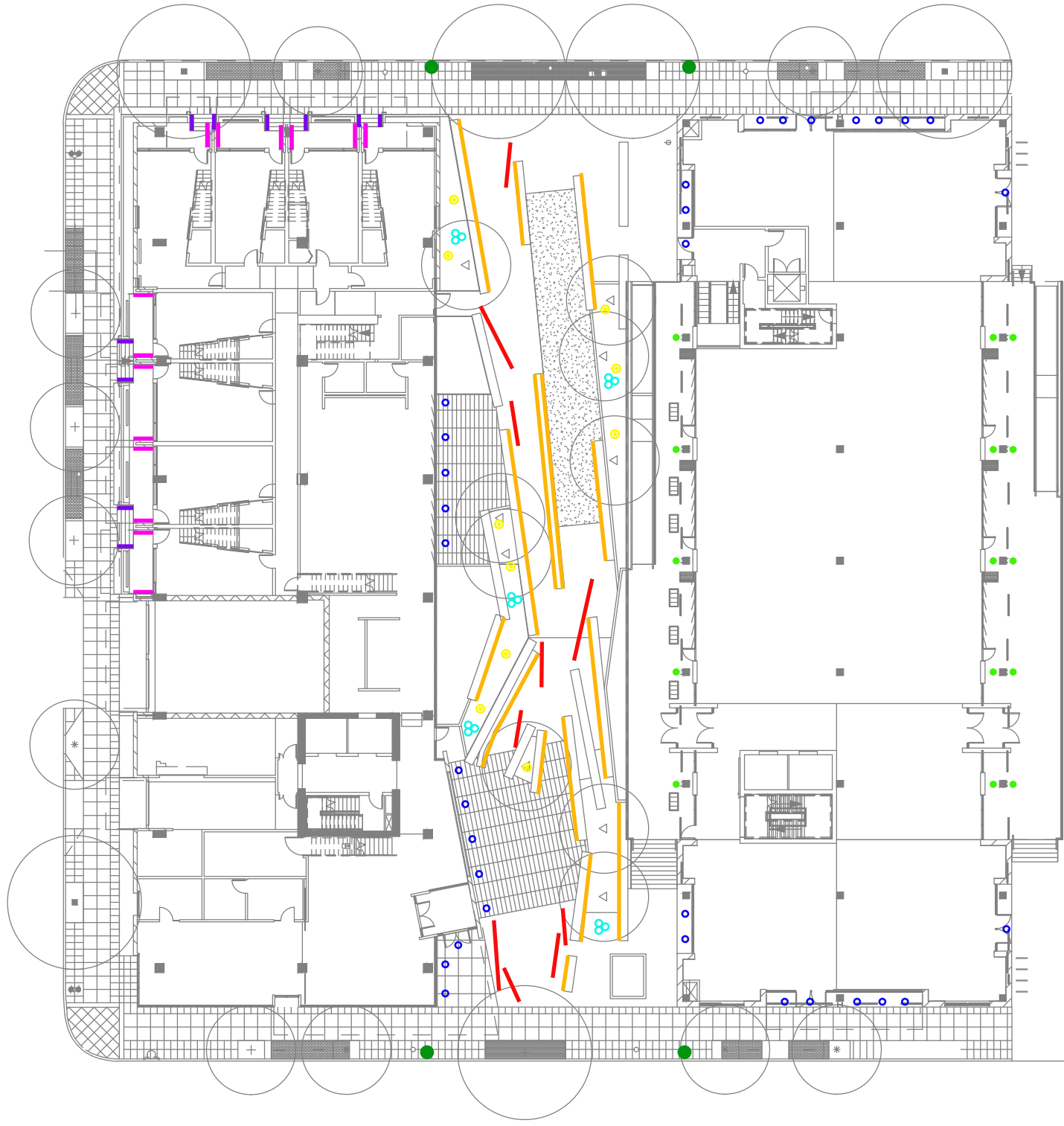

ACCENT LANDSCAPE

PROVIDE AMBIENT LIGHT

# Appendix A - Miscellaneous Plans

## Lighting - Fixtures



FIXTURE TYPE	GOAL	INTENT
 city provided pedestrian pole	identify entry points	create sense of security
 surface/pendant downlight v2 lighting core sx series	define building edge	create outdoor spaces
 in-grade column uplight bega 7019	define building edge	create outdoor spaces
 surface mount downlight v2 lighting core sx series	define building edge	create outdoor spaces
 multi-head floodlight on pedestrian pole bk denali series	provide ambient light	create safe environment
 tape light in channel tivoli outdoor low brightness 3.0	define circulation	illuminate benches
 in-grade linear lumenpulse lumentacade series	define circulation	illuminate pathways
 recessed step light bega 2382	define circulation	illuminate steps
 surface mounted floodlight bega 7604	accent landscape	create visual interest



# Appendix A - Miscellaneous Plans

## Lighting - Illumination Maps

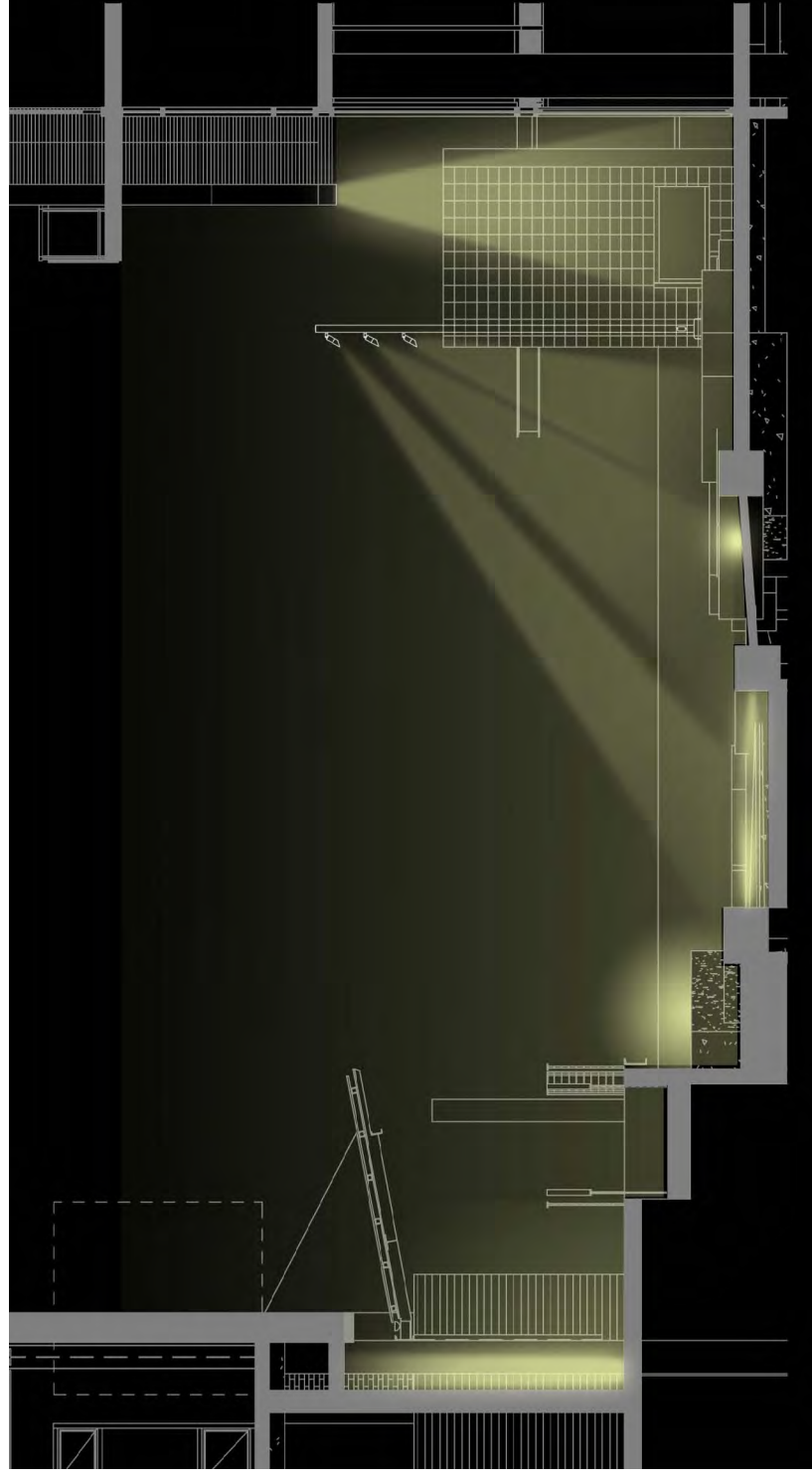
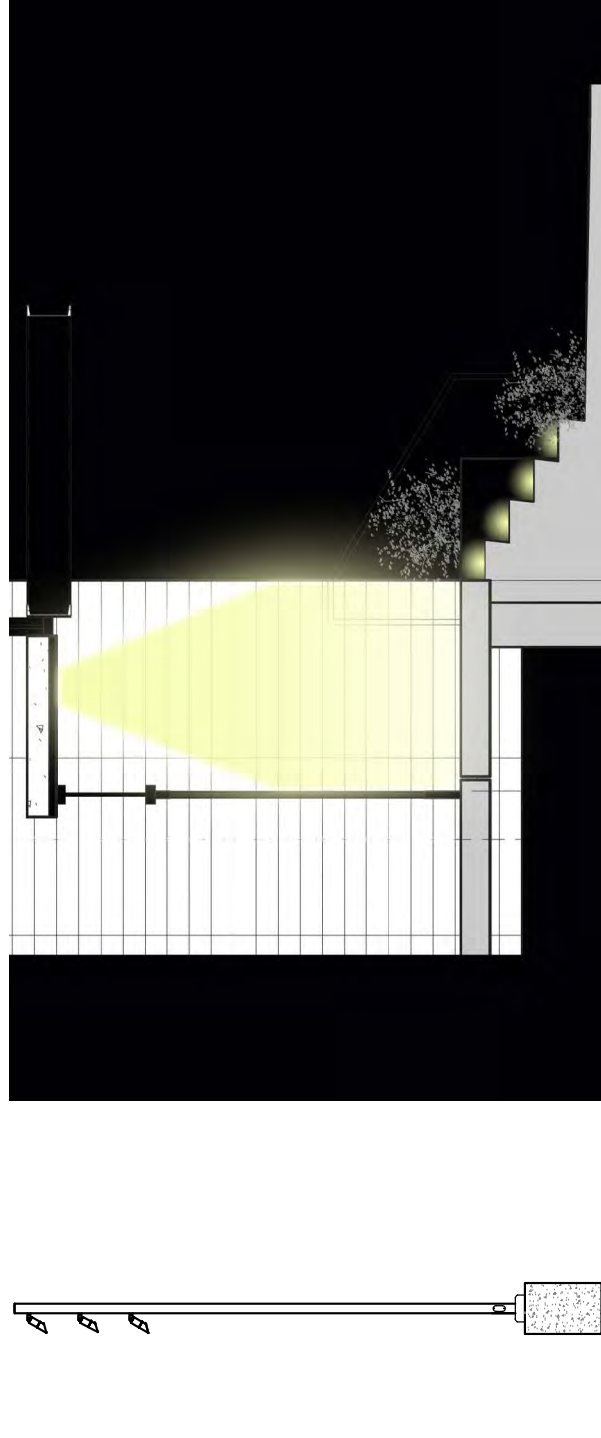
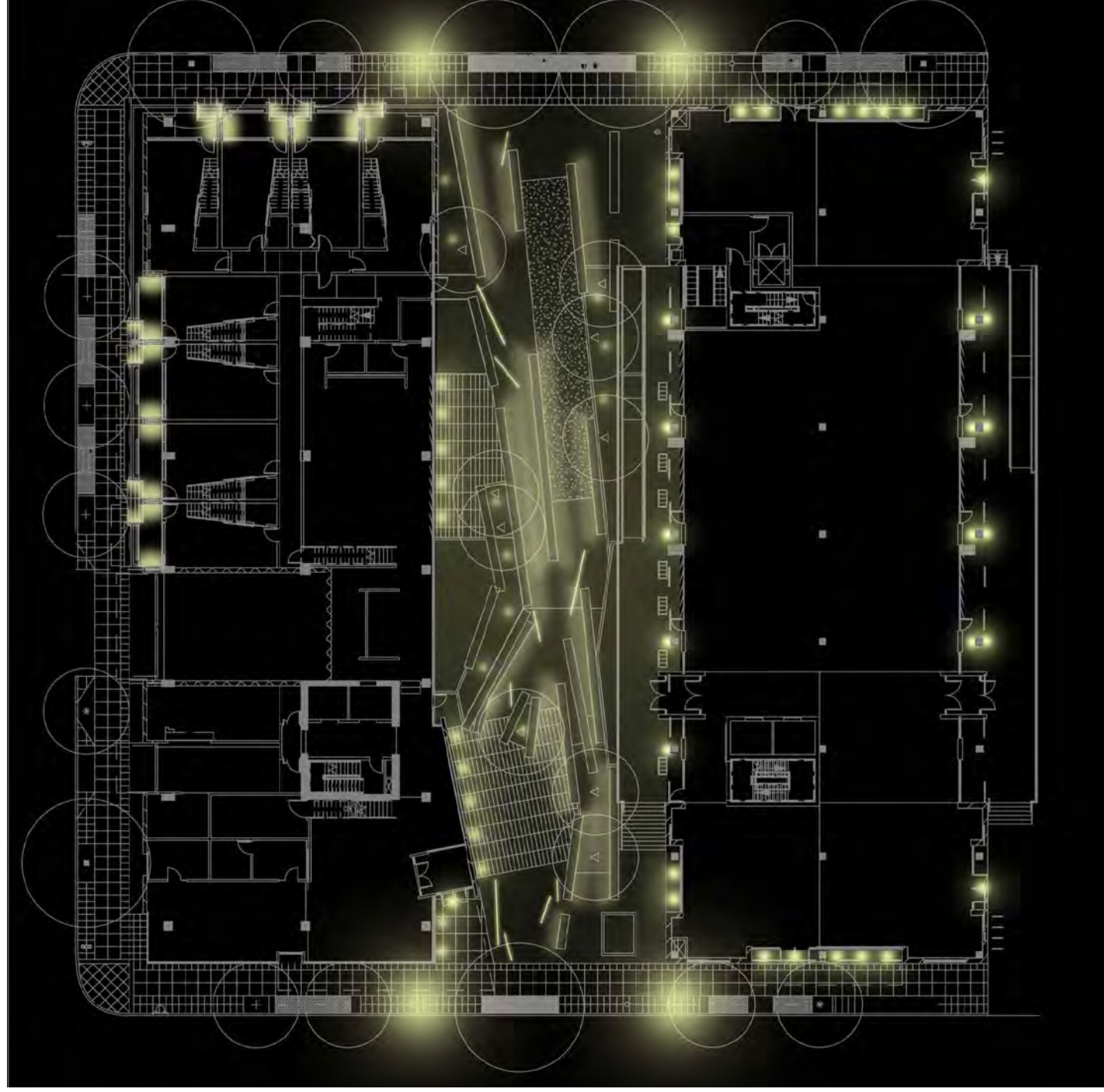

# Appendix B - 30' Height Request

## Floor Area Bonuses

### Floor Area Bonuses

Category	Max FAR Bonus	Area from Bonus (GSF)	FAR Earned	Notes
Site Area 40,000				
Base FAR Allowed Outright Map 510-2	4.00	160,000	4.00	
Residential Bonus 210.C.1	3.00	162,542	4.06	12th Ave Bldg Levels 1-12
Roof-top Gardens Bonus 210.C.4	n/a	7,823	0.20	12th Ave Bldg
Eco-Roof Bonus 210.C.10	n/a	27,156	0.68	13th Ave Bldg
<b>Total</b>	<b>7.00</b>	<b>357,521</b>	<b>8.94</b>	<b>2.12 extra</b>

Achieving FAR Bonus of 3.00 automatically qualifies for a 45' height bonus.

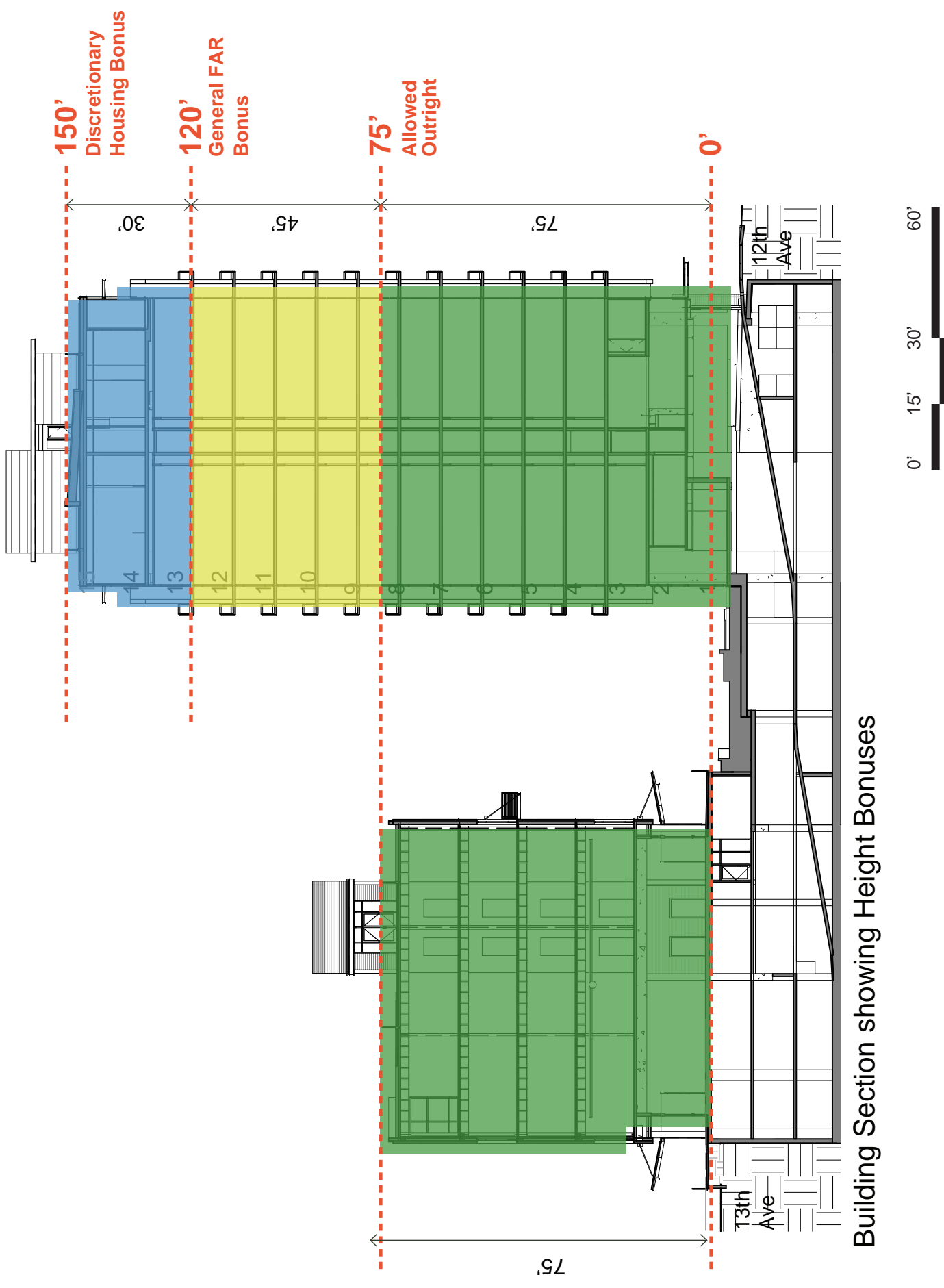

# Appendix B - 30' Height Request

## River District Zoning Base Heights

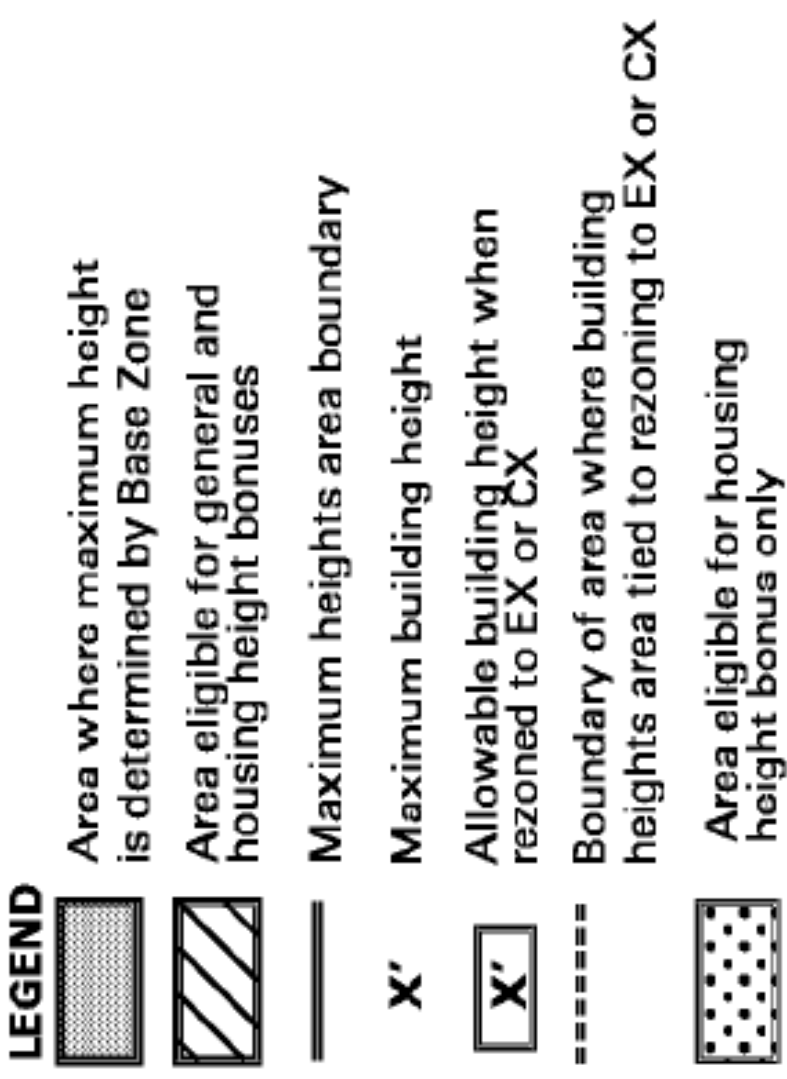

### 33.510.210 Floor Area and Height Bonus Options

D. General bonus heights. Bonus height is also earned at certain locations in addition to the bonus floor area achieved through the bonus options. Bonus height is in addition to the maximum heights of Map 510-3. Qualifying areas, shown on Map 510-3, are located such that increased height will not violate:



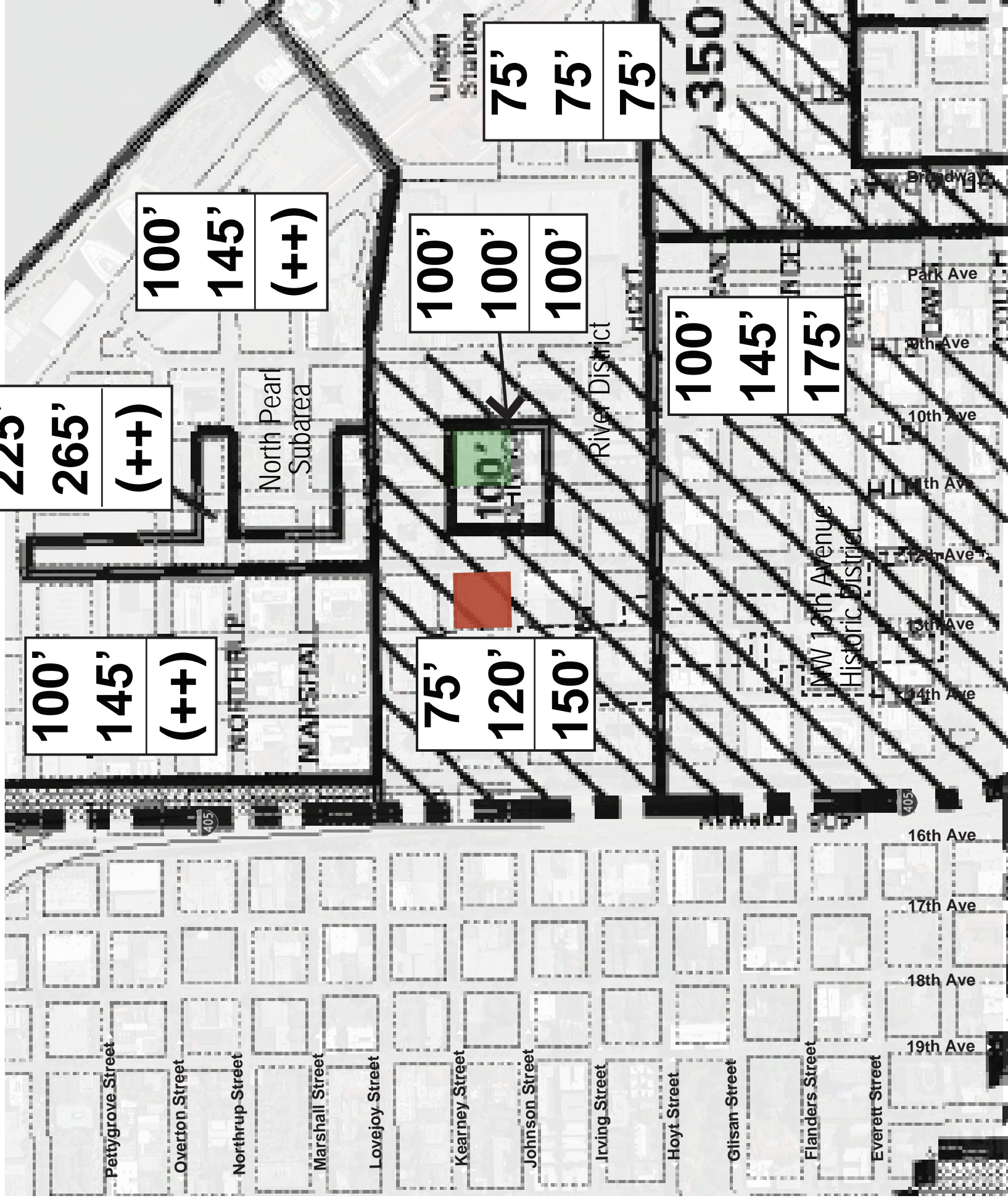

- established view corridors,
- the preservation of the character of historical districts,
- the protection of public open spaces from shadow, and
- the preservation of the City's visual focus on important buildings (such as the Union Station Clock Tower).

# Appendix B - 30' Height Request

## Zoning Bonus Height Maximums

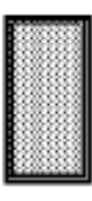

### LEGEND

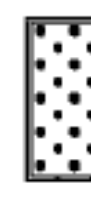
-  Area where maximum height is determined by Base Zone
-  Area eligible for general and housing height bonuses
-  Maximum heights area boundary
- X'** Maximum building height
-  Allowable building height when rezoned to EX or CX
-  Boundary of area where building heights area tied to rezoning to EX or C
-  Area eligible for housing height bonus only

### Height Key:

<b>75'</b>	Base Height from Map 510-3
<b>120'</b>	FAR Height (Automatic) Bonus
<b>150'</b>	Housing Height Bonus
<b>(+++)</b>	North Pearl Specific Bonuses

# Appendix B - 30' Height Request

## Existing Nearby Building Heights



### Legend

- 0' to 25'
- 25' to 50'
- 50' to 75'
- 75' to 100'
- 100' to 125'
- 125' to 150'
- 150' to 175'
- 175' to 200'
- 200' to 225'

### \* Housing Bonus Projects

- The Casey, 175' tall - 311 NW 12th Ave
- Park Place, 150' tall - 922 NW 11th
- The Henry, 175' tall - 1025 NW Couch
- The Louisa, 175' tall - 123 NW 12th

# Appendix B - 30' Height Request

## Zoning Code Requirements

### **33.510.210 E. Bonus height option for housing.**

- 1.** Generally. In the bonus height areas, building heights may be allowed to be greater than shown on Map 510-3 if the bonus height is for housing. Although this subsection allows the review body to approve bonus height, the review body may also require reconfiguration of the building, including reducing its height, and may approve all, some or none of the bonus height requested, based on application of the criteria in E.4, below.
- 2.** Standard. The maximum height bonus that may be allowed is **75 feet**.
- 3.** Relationship to Subsection D.
  - a. On sites shown on Map 510-3 as eligible for general and housing height bonuses, both the bonus height options of this subsection and Subsection D., above may be used. However, if both options are used, the combined bonus height may not exceed 75 feet. Bonus height in excess of the maximum allowed through Subsection D., above, must be used exclusively for housing, and may not be used to qualify for the residential floor area bonus option in Subsection C.1., above;
  - b. On sites shown on Map 510-3 as eligible for housing height bonuses, only the housing height bonus of this subsection may be used.

# Appendix B - 30' Height Request

## Zoning Code Requirements

- 4. Approval Criteria.** The approval of the bonus height is made as part of the design review of the project. The bonus height may be approved if the review body finds that the applicant has shown that all of the following criteria have been met:
- a. The increased height will not violate an established view corridor; **(met)**
  - b. If the site is within 500 feet of an R zone, the proposed building will not cast shadows...; **(met)**
  - c. If the site is shown on Map 510-3 as eligible for the Open Space (OS) performance standard...; **(met)**
  - d. If the site is on a block adjacent to the Yamhill or Skidmore Fountain/Old Town...; **(met)**
  - e. The increased height will result in a project that better meets the applicable **design guidelines**;
  - f. and Approval of the increased height is consistent with the purposes stated in Subsection 33.510.205.A. **(next page)**

# Appendix B - 30' Height Request

## Zoning Code Requirements

### **33.510.205 A. Height.**

A. Purpose. The maximum building heights are intended to accomplish several purposes of the Central City Plan. These include:

- protecting **views**,
- creating a stepdown of building heights to the **Willamette River**,
- limiting shadows on public **open spaces**,
- ensuring building height compatibility and step downs to **historical districts**, and
- limiting shadows from new development on **residential** neighborhoods in and at the edges of the Central City.



# Appendix B - 30' Height Request

Zoning - Open Space Performance Standard

## 33.510.205 C. Height.

C. Performance standard for sites adjacent to designated open spaces. (Not applicable to Block 136)

2. The performance standard. Building heights may be increased if the amount of shadow cast by the proposed building on the adjacent open space will be less than or equal to the shadow that would result from an allowed building constructed to the maximum height shown on Map 510-3. (75')

The shadow from an allowed building is based on the shadow that would be cast by a structure covering the entire site at the height limit of Map 510-3. Shadows must be analyzed for noon and 3:00 p.m. on April 21 to determine compliance with this provision.



Riverstone shadow on Jamison Square +/- 6:15 pm May 20

# Appendix B - 30' Height Request

Jamison Square Sun Study - Without Proposed Project

March 21, 5:30 PM

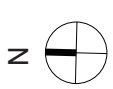

# Appendix B - 30' Height Request

Jamison Square Sun Study at Proposed Height - 120'

March 21, 5:30 PM



# Appendix B - 30' Height Request

Jamison Square Sun Study at Proposed Height - 150'

March 21, 5:30 PM

