



MIRACLES CENTRAL DESIGN REVIEW

The Miracles Club



CARLETON HART
ARCHITECTURE 

PROJECT GOALS & PROGRAM

PROJECT DEVELOPER:

- MULTI-CULTURAL DEVELOPMENT GROUP, LLC

CO-DEVELOPER & PROPERTY MANAGER:

- GUARDIAN REAL ESTATE SERVICES, LLC

CO-SPONSORS:

- MIRACLES CLUB
- CENTRAL CITY CONCERN
- WORKING TOGETHER TO PROVIDE SUPPORTIVE RECOVERY BASED HOUSING
- 47 UNITS OF AFFORDABLE HOUSING
- COMMUNITY SUPPORT SERVICES
- SIX STORIES - WOOD FRAMING OVER A CONCRETE PODIUM APPROXIMATELY 47,500 SF

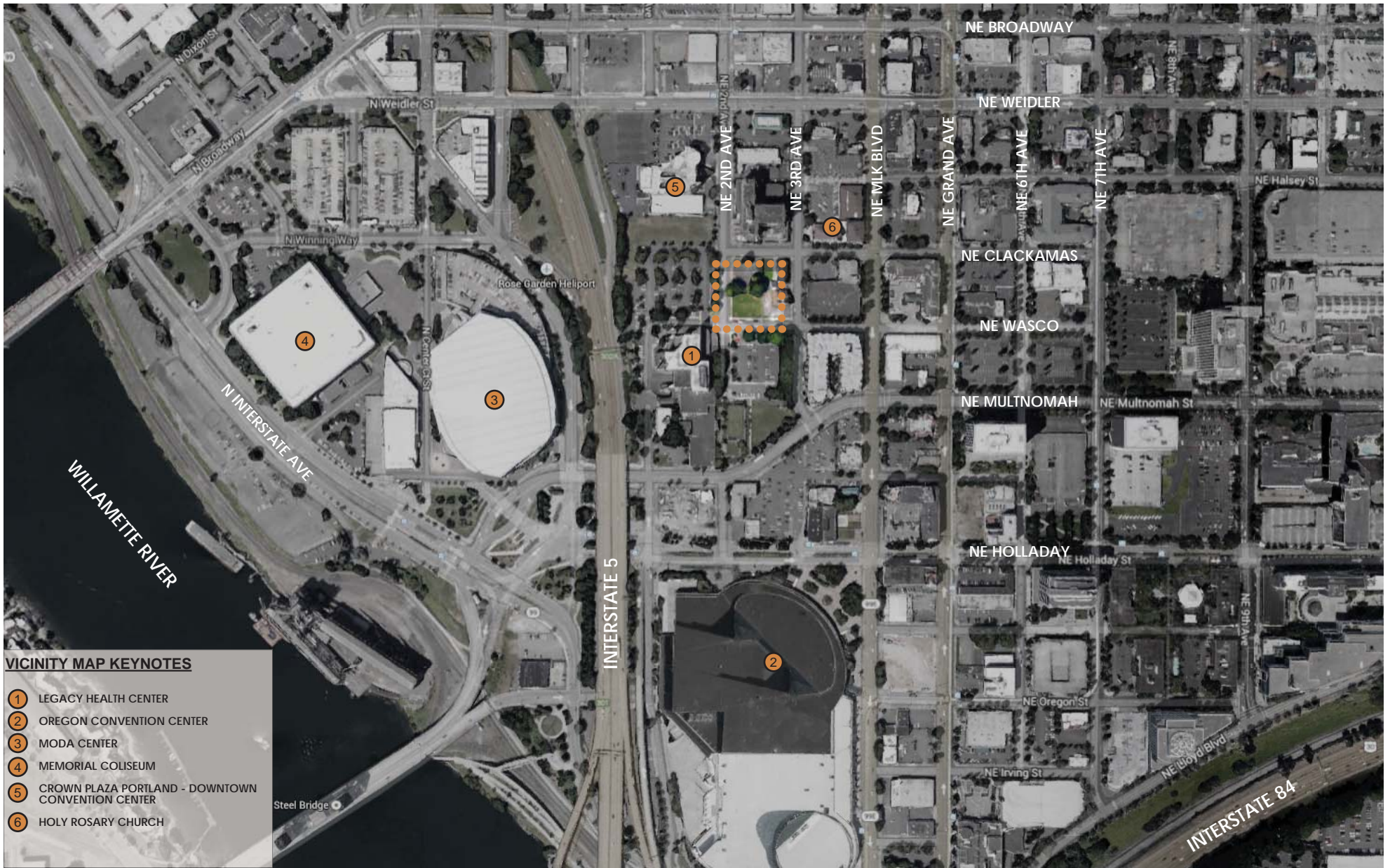

VICINITY MAP KEYNOTES

- ① LEGACY HEALTH CENTER
- ② OREGON CONVENTION CENTER
- ③ MODA CENTER
- ④ MEMORIAL COLISEUM
- ⑤ CROWN PLAZA PORTLAND - DOWNTOWN CONVENTION CENTER
- ⑥ HOLY ROSARY CHURCH



VICINITY MAP



SITE PLAN & FIRST FLOOR PLAN

MIRACLES CENTRAL

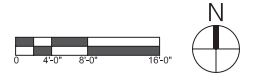

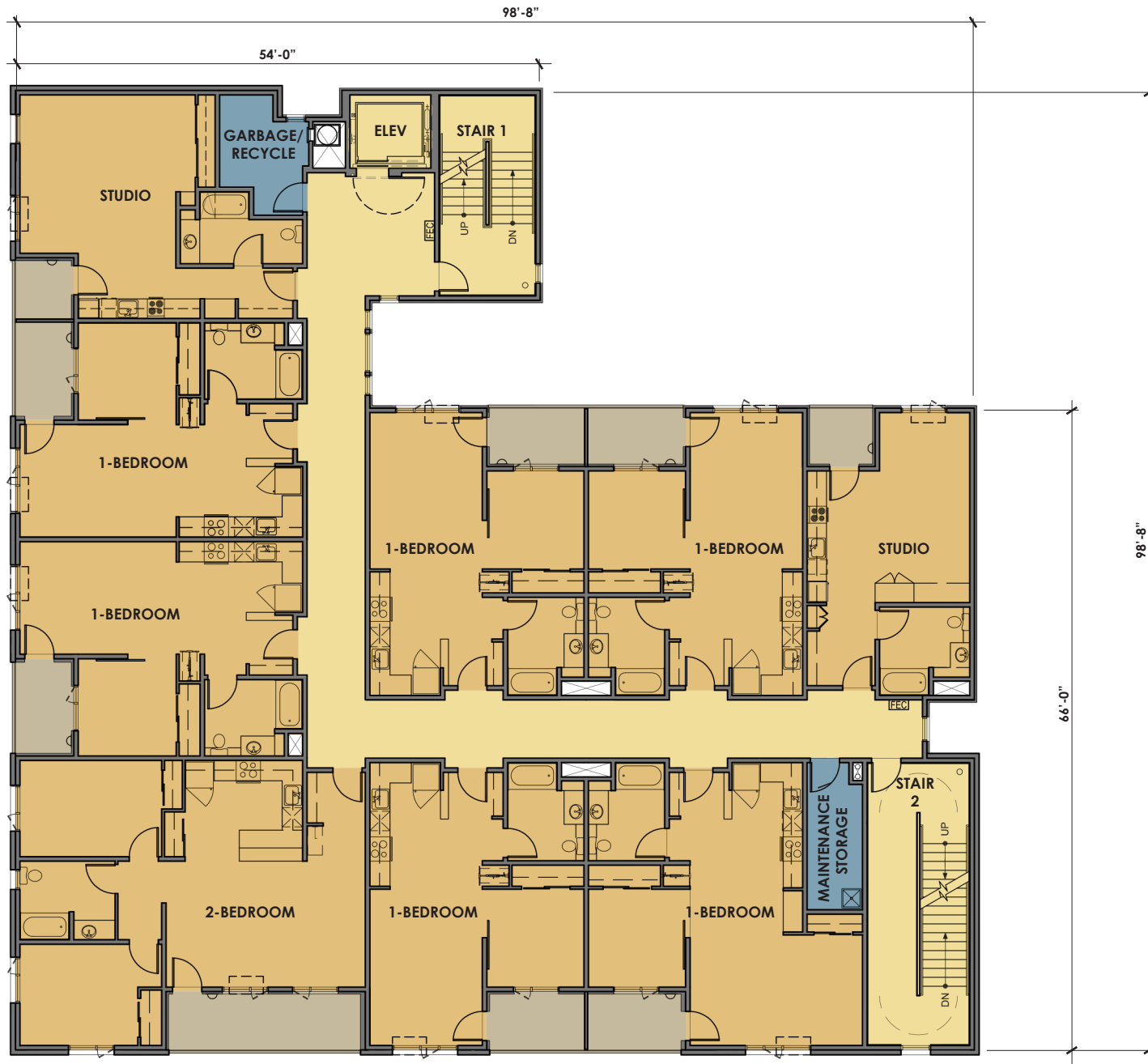

TYPICAL RESIDENTIAL FLOOR PLAN

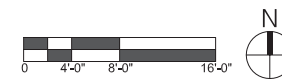



SIXTH FLOOR PLAN

MIRACLES CENTRAL

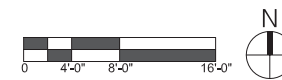

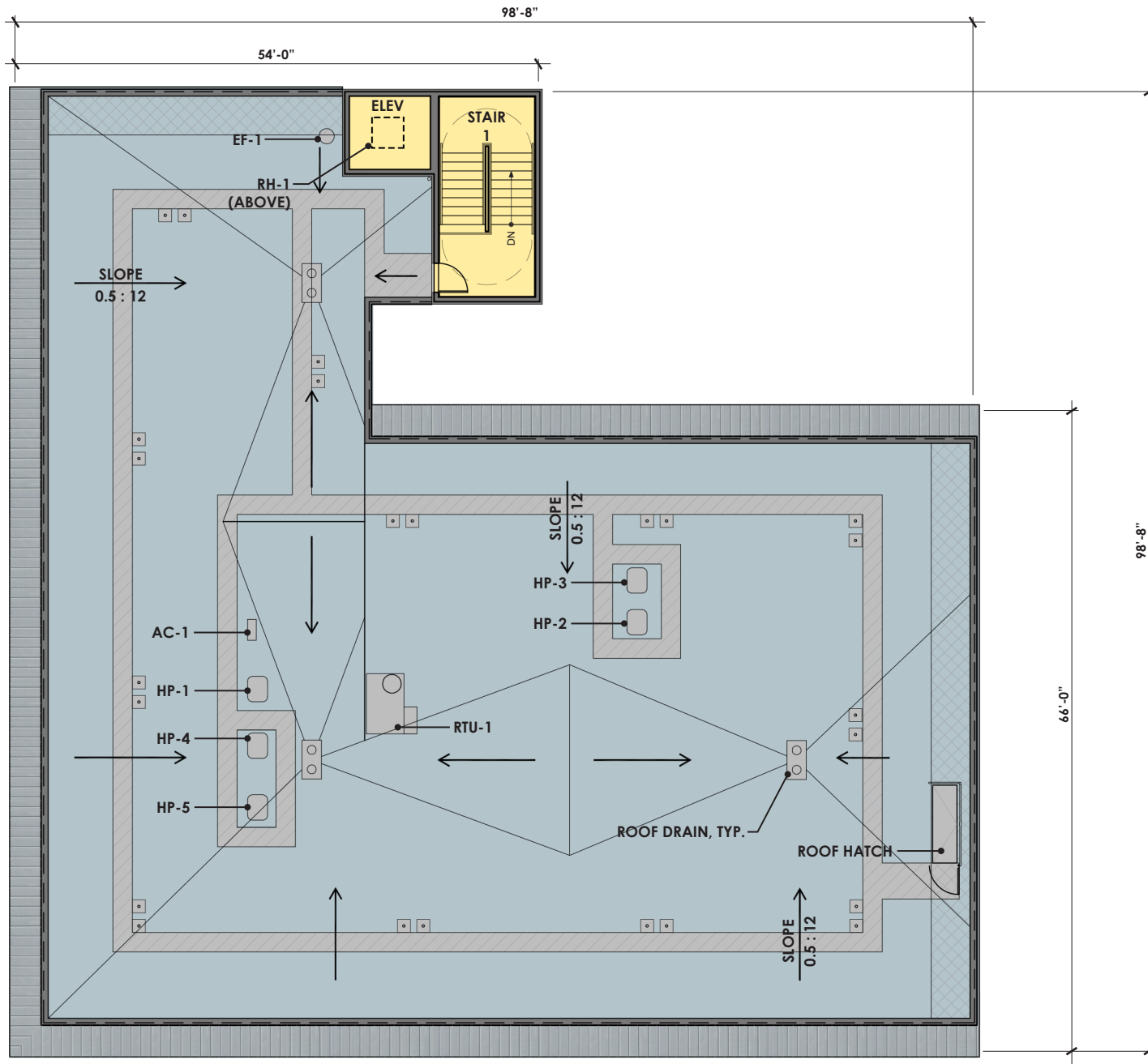

ROOF PLAN

MIRACLES CENTRAL

REVIEW OF DESIGN COMMENTS

STREETSCAPE

- PLANTERS REMOVED @ CORNER AND ALONG WASCO ST
- GAS METER NOW RECESSED IN BUILDING CORNER
- EXTEND BRICK AT FIRST FLOOR TO ENCOMPASS ALL OF THE COURTYARD FACADES



SOUTH ELEVATION - OLD

MIRACLES CENTRAL

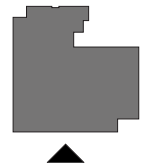



WEST ELEVATION - OLD

MIRACLES CENTRAL

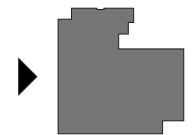



UNIT BALCONIES

63'-0"

10'1/2"

COMMUNITY MEETING ROOM

REMOVED ALL PLANTERS ALONG
WASCO STREET FOR A MORE
URBAN EDGE

MENTORING OFFICES

RECESSED GAS METER INTO
BUILDING ALCOVE

SOUTH ELEVATION - NEW

MIRACLES CENTRAL

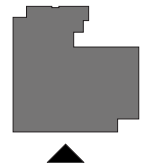



WEST ELEVATION - NEW

MIRACLES CENTRAL

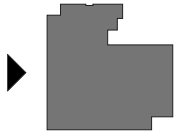



GROUND FLOOR PLAN - OLD



GROUND FLOOR PLAN - NEW

GAS METER NOW LOCATED
IN BUILDING RECESS

PLANTERS @ CORNER AND ALONG
WASCO STREET REPLACED WITH
EXTENSION OF SIDEWALK

GROUND FLOOR PLAN ADJUSTMENTS





VIEW FROM SOUTHWEST - OLD



VIEW FROM SOUTHWEST - NEW



VIEW FROM SOUTHEAST - OLD



11.20.2014

VIEW FROM SOUTHEAST - NEW



RESIDENTIAL ENTRANCE PEDESTRIAN PERSPECTIVE - OLD



RESIDENTIAL ENTRANCE PEDESTRIAN PERSPECTIVE - NEW

11.20.2014

REVIEW OF DESIGN COMMENTS

ELEVATIONS

- EXTENDED BRICK TO EDGES OF PROPERTY ON STREET FACADES BY REDISTRIBUTING BRICK AREAS FROM THE COURTYARD ELEVATION
- SIMPLIFY WINDOW TYPES AT STAIR AND STUDIO UNITS. MAKE THESE WINDOWS MATCH OTHER LARGER OPENING TYPE



SOUTH ELEVATION - OLD

MIRACLES CENTRAL

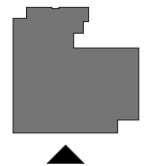



WEST ELEVATION - OLD

MIRACLES CENTRAL

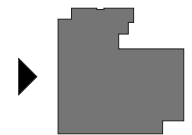



RECESSED LANDSCAPE
COURTYARD (BEYOND)

NORTH ELEVATION - OLD

MIRACLES CENTRAL

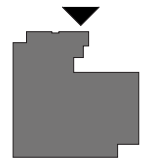

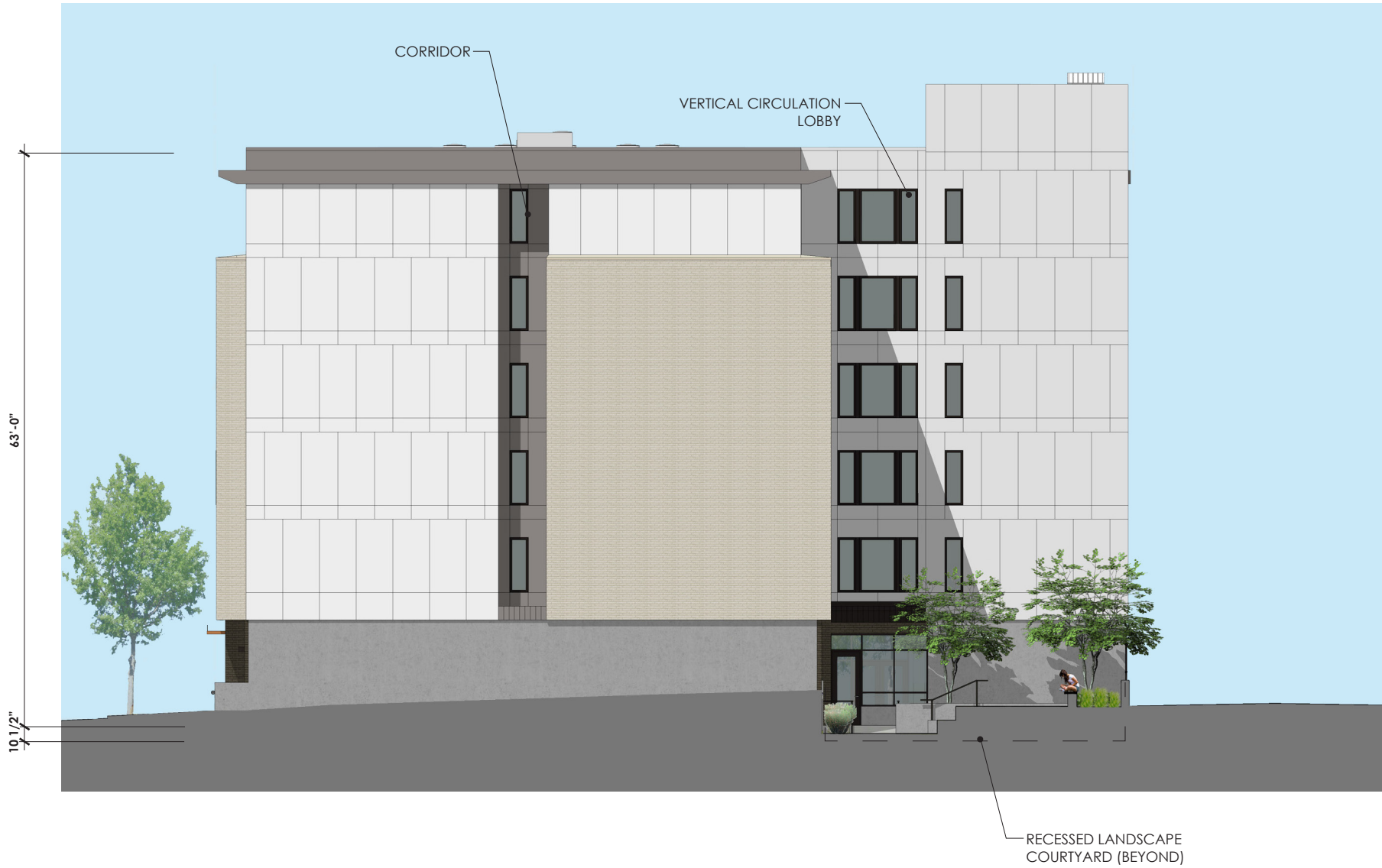

EAST ELEVATION - OLD

MIRACLES CENTRAL

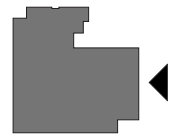



SOUTH ELEVATION - NEW

MIRACLES CENTRAL

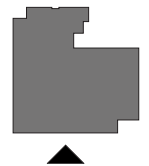

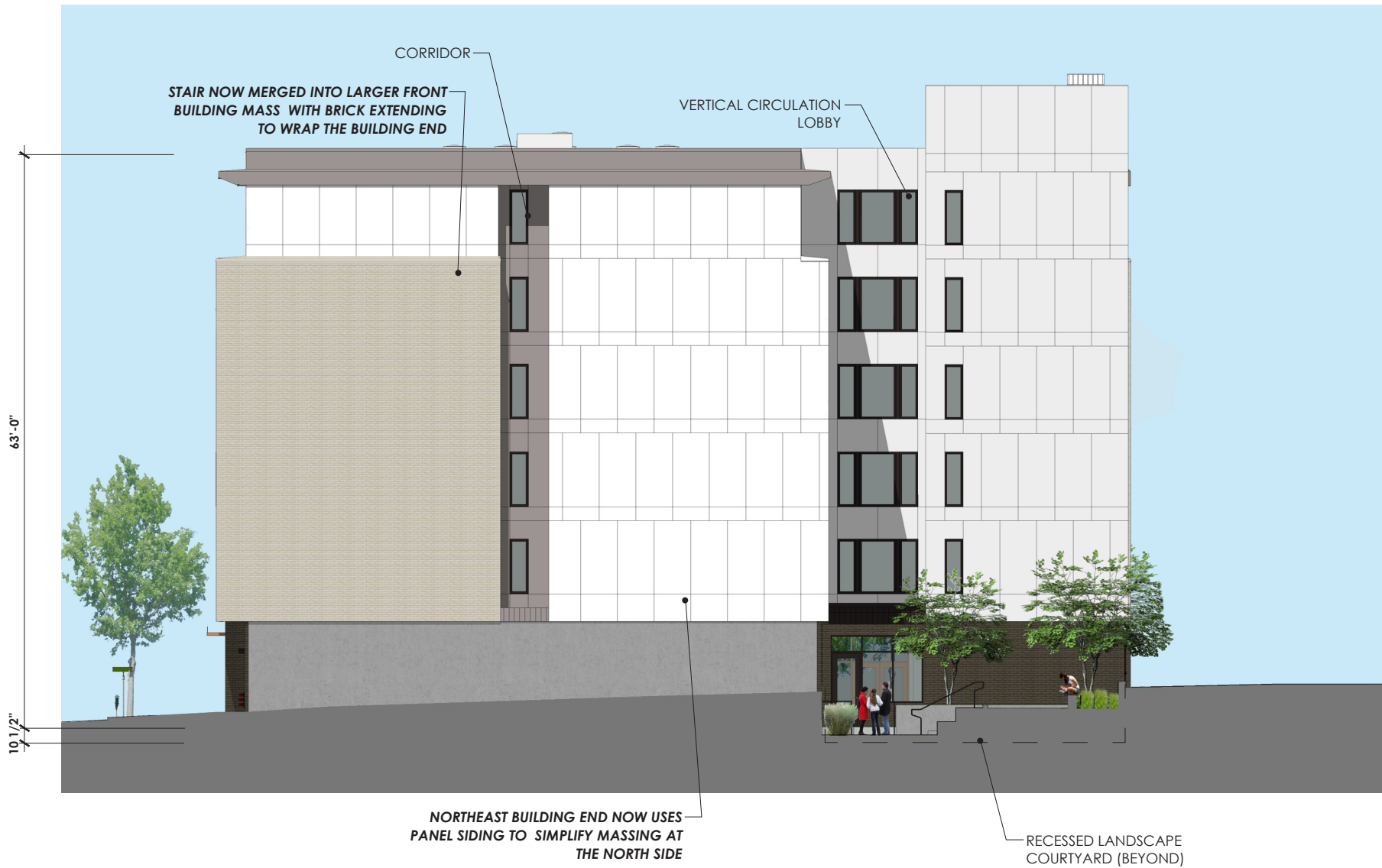

EAST ELEVATION - NEW

MIRACLES CENTRAL



VIEW FROM SOUTHEAST - OLD



VIEW FROM SOUTHEAST - NEW

PEDESTRIAN EXPERIENCE / GAS METER / STAIR WINDOW ADJUSTMENTS

MIRACLES CENTRAL



WEST ELEVATION - NEW

MIRACLES CENTRAL

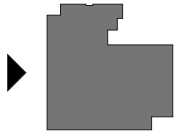



NORTH ELEVATION - NEW

MIRACLES CENTRAL



VIEW FROM NORTHWEST - OLD



VIEW FROM NORTHWEST - NEW

PEDESTRIAN EXPERIENCE / UNIT WINDOW ADJUSTMENTS



TYPICAL FLOOR PLAN - OLD



TYPICAL FLOOR PLAN - NEW

EXTEND THE FLOOR PLATE TO SIMPLY BUILDING MASSING

CONSOLIDATE SMALLER SPACES WHERE POSSIBLE AND INTEGRATE STAIR CORE INTO BUILDING FACADE

TYPICAL FLOOR PLAN ADJUSTMENTS





VIEW FROM SOUTHWEST

MIRACLES CENTRAL



VIEW FROM NORTHWEST

MIRACLES CENTRAL



VIEW FROM SOUTHEAST

MIRACLES CENTRAL



BIRD'S EYE VIEW OF COURTYARD

MIRACLES CENTRAL





VIEW FROM NORTHWEST - ALTERNATE STUDY B

MIRACLES CENTRAL



VIEW FROM SOUTHEAST - ALTERNATE STUDY B

MIRACLES CENTRAL



BIRD'S EYE VIEW OF COURTYARD - ALTERNATE STUDY B

MIRACLES CENTRAL



BIRD'S EYE VIEW OF COURTYARD - OLD

MIRACLES CENTRAL



NORTH ELEVATION - ALTERNATE STUDY B

MIRACLES CENTRAL



EAST ELEVATION - ALTERNATE STUDY B

MIRACLES CENTRAL



VIEW FROM SOUTHEAST - ALTERNATE STUDY C

MIRACLES CENTRAL



BIRD'S EYE VIEW OF COURTYARD - ALTERNATE STUDY C

MIRACLES CENTRAL



EAST ELEVATION - ALTERNATE STUDY C

MIRACLES CENTRAL

REVIEW OF DESIGN COMMENTS

DETAILS

- BRICK EAVE PROFILE AND FLASHING
- BALCONY RAILING CONNECTION

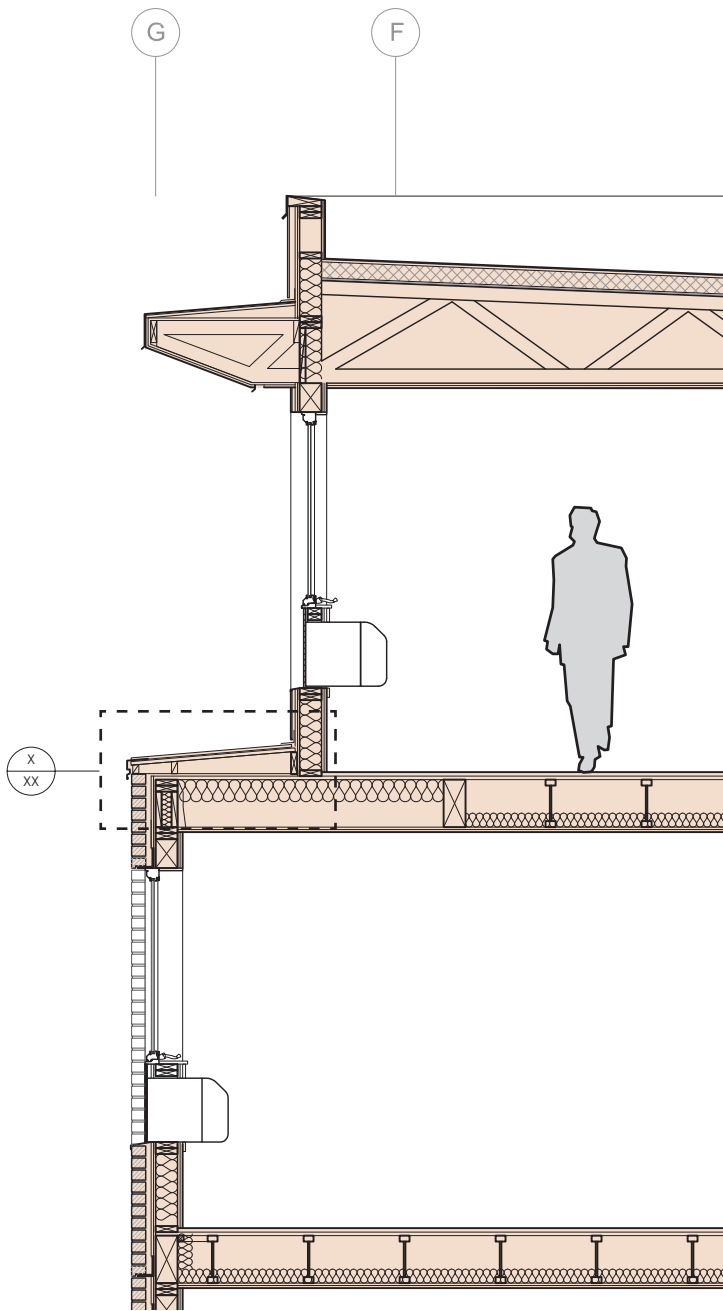

ENLARGED WALL SECTION



METAL ROOF @ 5TH FLOOR

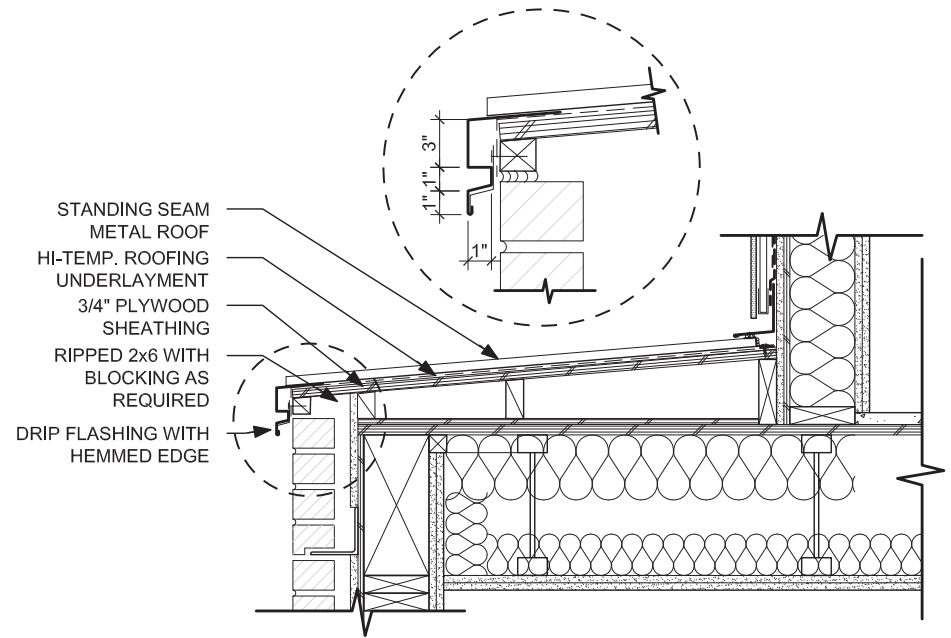

3. STANDING SEAM METAL ROOF @ 6TH FLOOR





CLOSE-UP OF BALCONY RAILING



BALCONY REFERENCE

BALCONY RAILING

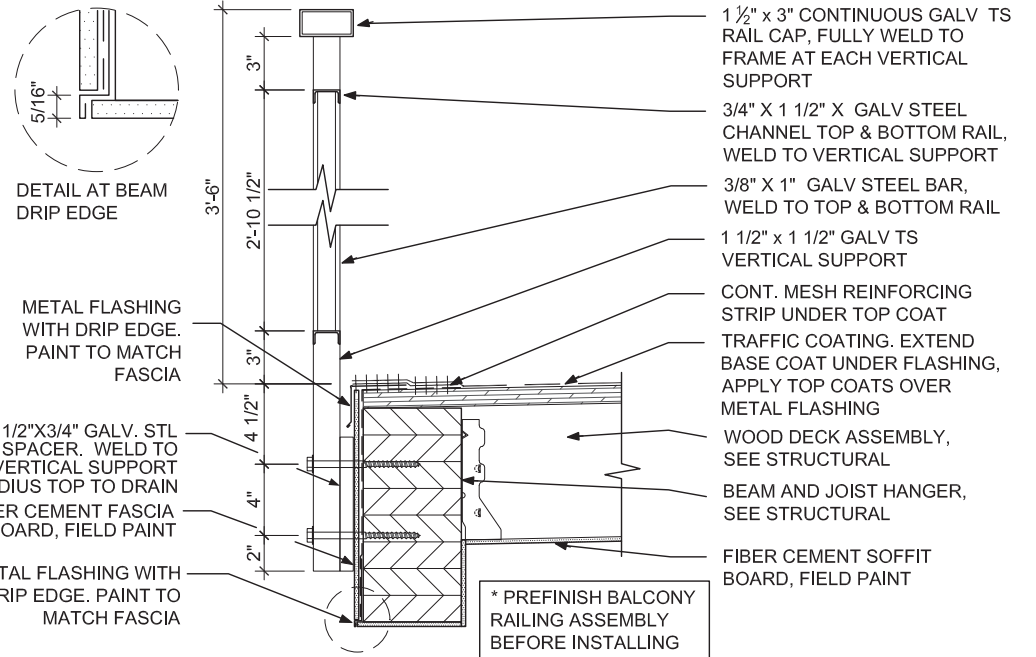

BALCONY RAILING SUPPORT





VIEW FROM SOUTHEAST - DESIGN ADVICE REQUEST

MIRACLES CENTRAL



VIEW FROM NORTHWEST - DESIGN ADVICE REQUEST

MIRACLES CENTRAL



VIEW FROM SOUTHWEST - DESIGN ADVICE REQUEST

MIRACLES CENTRAL



VIEW FROM SOUTHEAST - DESIGN REVIEW HEARING 1

MIRACLES CENTRAL



VIEW FROM NORTHWEST - DESIGN REVIEW HEARING 1

MIRACLES CENTRAL



VIEW FROM SOUTHWEST - DESIGN REVIEW HEARING 1

MIRACLES CENTRAL



VIEW FROM SOUTHEAST - CURRENT

MIRACLES CENTRAL



VIEW FROM NORTHWEST - CURRENT

MIRACLES CENTRAL



VIEW FROM SOUTHWEST - CURRENT

MIRACLES CENTRAL