



contents

Cover.....	1
Contents.....	2
View from South.....	3
Neighborhood Context.....	4
Neighborhood Context.....	5
Neighborhood Context.....	6
Site Inspiration.....	7
Vicinity Map.....	8
Three Block Study.....	9
Site Plan.....	10
Storm Water/Utility Plan.....	11
Lighting Plan.....	12
FAR Diagrams.....	13
Level 1 Floor Plan.....	14
Level 2 Floor Plan.....	15
Level 3-6 Floor Plan.....	16
Roof Plan.....	17
Elevations.....	18
Elevations.....	19
Courtyard Elevations.....	20
Enlarged Elevation and Sections.....	21
Enlarged Elevation and Sections.....	22
Enlarged Elevation and Sections.....	23
Building Perspective From Northeast.....	24
Night Perspective From Northeast.....	25
Streetscape Plan.....	26
Streetscape South Elevation.....	27
Streetscape East Elevation.....	28
Streetscape East Elevation - Partial.....	29
Terraced Water Trays - Perspective.....	30
Terraced Water Trays - Section.....	31
2nd Level Terrace South Section.....	32
2nd Level Terrace Plan.....	33
2nd Level Terrace East Section.....	34
Terraced Water Trays - Details.....	35
Terraced Water Trays - Details.....	36
Terrace Details.....	37
Materials.....	38
Enlarged View of Slate Veneer.....	39
Parking Entry and Louver Sections.....	40
Storefront/Window Details.....	41
Window Details.....	42
Shadowbox Details.....	43
Wall Details.....	44
Wall Details.....	45
Roof Screen.....	46
Level 1 Retail.....	47
West Elevation.....	48
North Elevation.....	49
East Elevation.....	50
South Elevation.....	51
North Courtyard Elevation.....	52
South Courtyard Elevation.....	53
East Courtyard Elevation.....	54





view to south



view to east



view to north



view to west



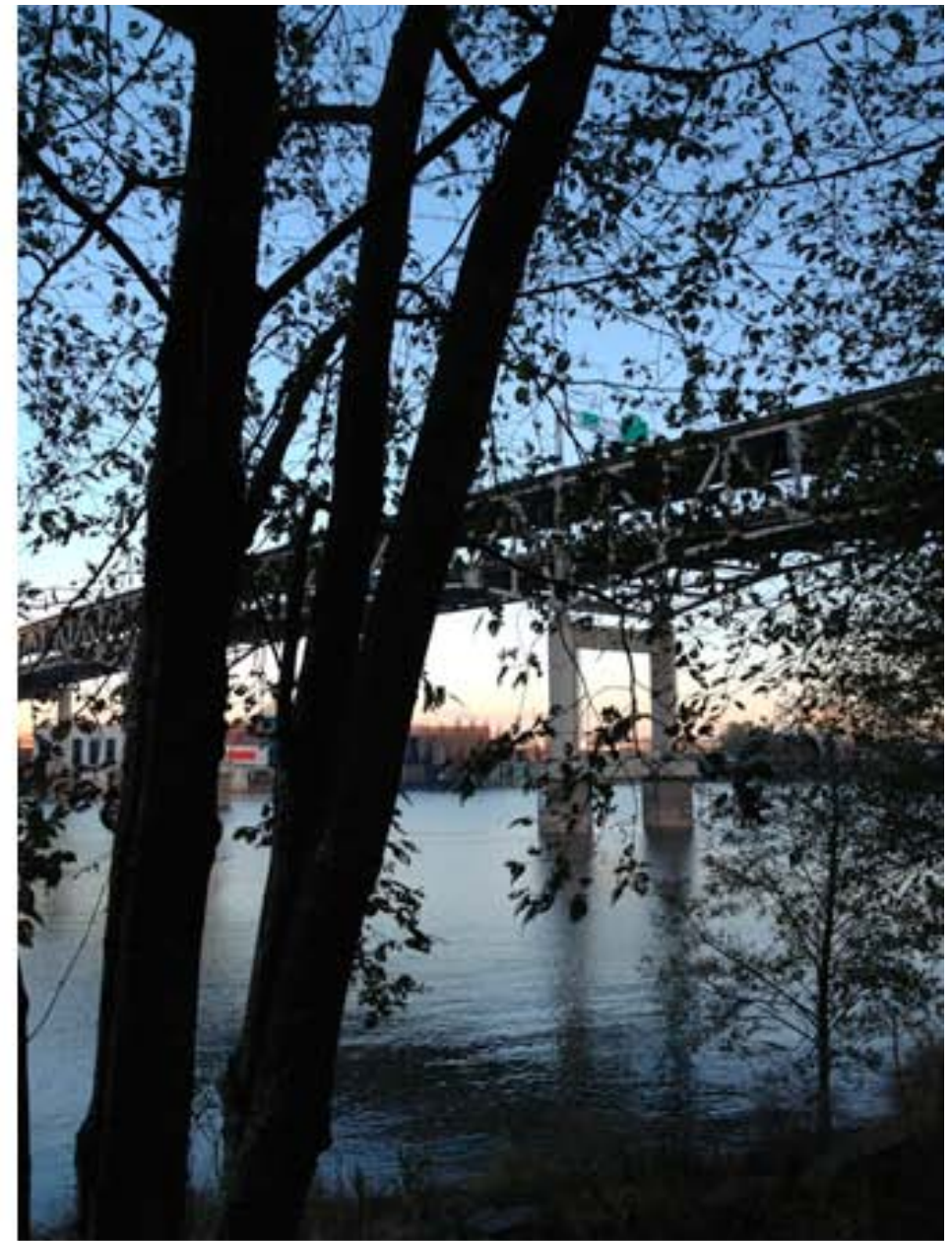



SITE
48,645 SF



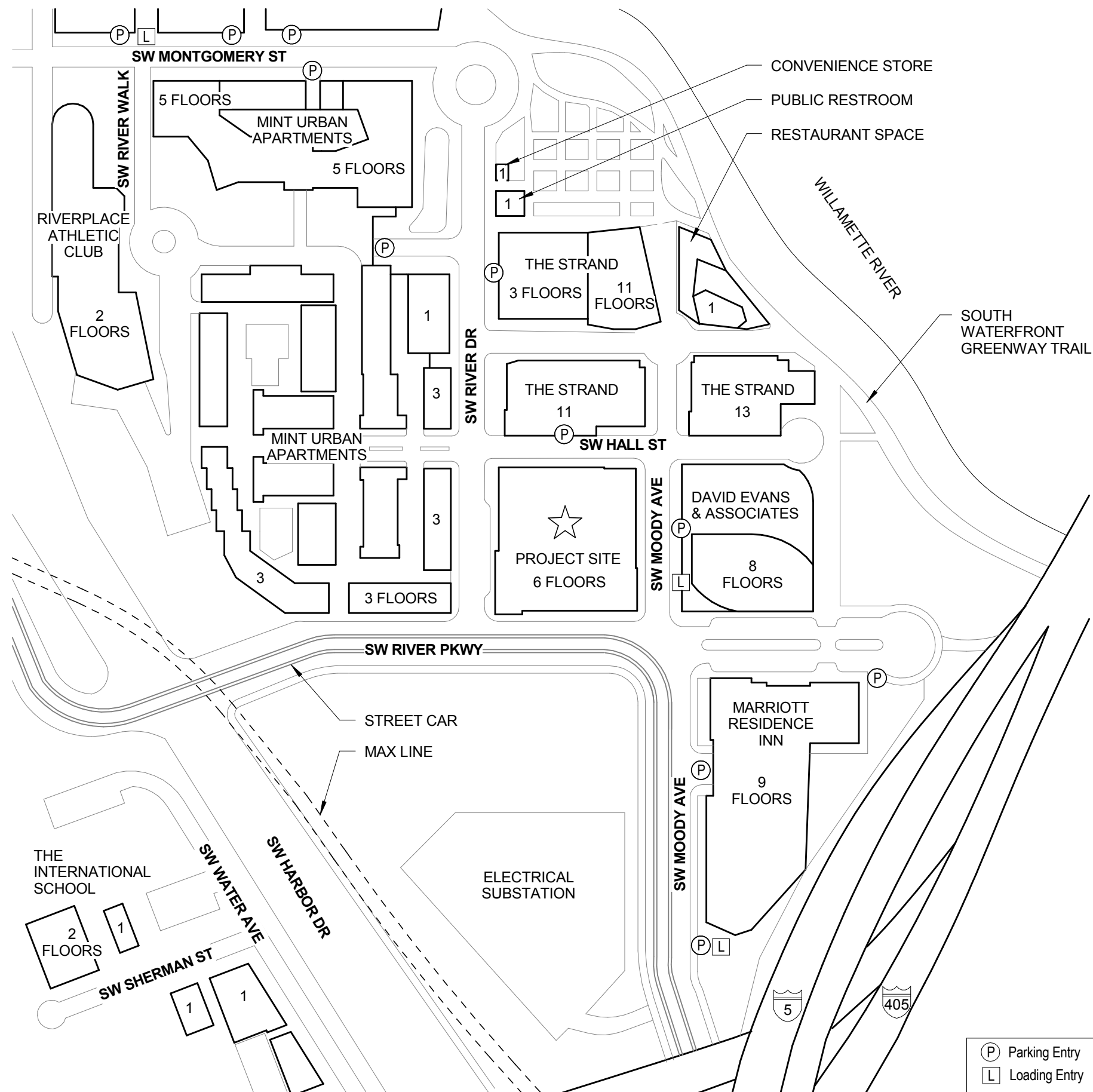



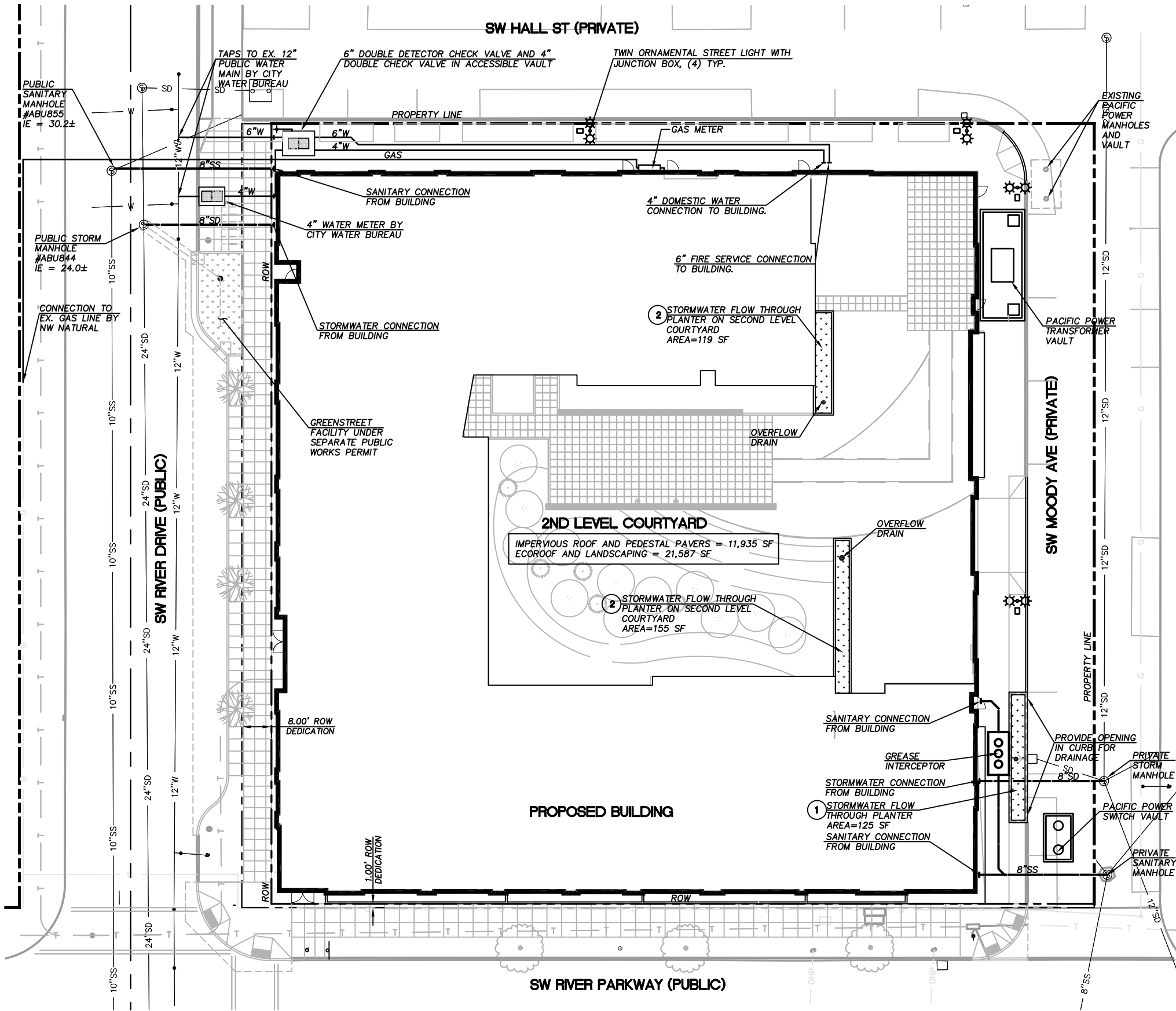

STORMWATER NARRATIVE

PRIVATE:
WATER QUALITY
 WATER QUALITY CONTROL IS MET WITH FLOW-THROUGH PLANTERS AND ECOROOF. THE PLANTERS AND ECOROOF ARE SIZED TO TREAT 93% OF THE ON-SITE IMPERVIOUS AREA. A SPECIAL CIRCUMSTANCE IS BEING REQUESTED FOR THE REMAINING IMPERVIOUS AREA.

WATER QUANTITY
 WATER QUANTITY CONTROL IS NOT REQUIRED PER BES PRE-APPLICATION CONFERENCE RESPONSE. (STORM-ONLY SEWER THAT DISCHARGES TO THE WILLAMETTE).

DISPOSAL
 A CONNECTION FROM THE SITE WILL BE MADE TO EXISTING PUBLIC STORM-ONLY SEWER. THE PROJECT WILL FALL UNDER CATEGORY 3 OF THE STORMWATER DISPOSAL HIERARCHY.

PUBLIC:
WATER QUALITY/QUANTITY
 STORMWATER MANAGEMENT IS REQUIRED FOR THE IMPROVEMENTS TO THE PUBLIC SIDEWALK IN THE PUBLIC RIGHT OF WAY ON SW RIVER DR. GREENSTREET FLOW-THROUGH PLANTERS WILL MANAGE NEW IMPERVIOUS AREA CONSTRUCTED ON SW RIVER DR. EXISTING STORMWATER DRAINAGE FOR THE RIGHT OF WAY WILL BE PROTECTED DURING CONSTRUCTION.

DISPOSAL
 DISPOSAL FOR THE GREENSTREET FLOW-THROUGH PLANTERS WILL BE TO THE PUBLIC STORM SEWER IN SW RIVER DR.

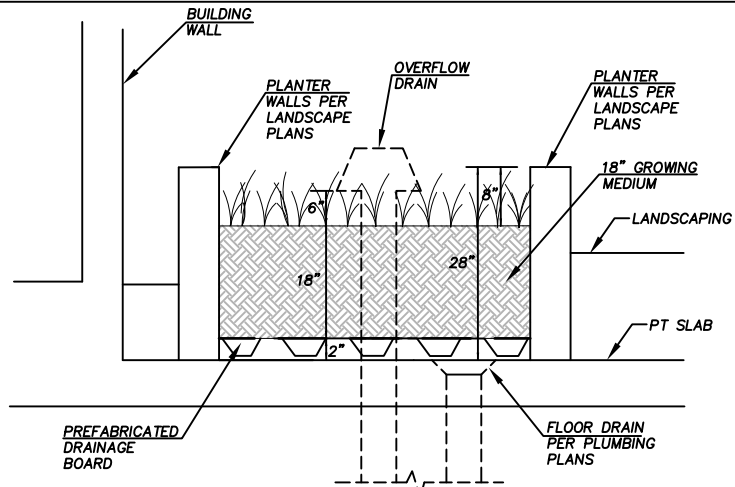

NOTES:
 1. PLANTING PER LANDSCAPE PLANS.
 2. GROWING MEDIUM PER SPECIFICATIONS.

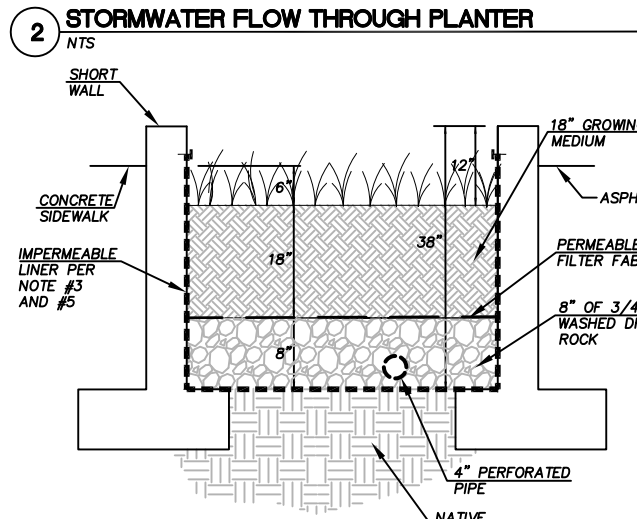

NOTES:
 1. PLANTING PER LANDSCAPE PLANS.
 2. GROWING MEDIUM PER SPECIFICATIONS.
 3. IMPERMEABLE LINER SHALL BE 30 MIL MINIMUM. ATTACH IMPERMEABLE LINER TO CONCRETE ABOVE OVERFLOW DRAIN.
 4. PROVIDE WATERTIGHT PENETRATION THROUGH IMPERMEABLE LINER FOR OUTFLOW FROM OVERFLOW DRAIN.
 5. CONCRETE PLANTER BOX SHALL BE POURED MONOLITHICALLY WITH NO COLD JOINTS TO AVOID THE REQUIREMENT FOR A LINER.

1 STORMWATER FLOW THROUGH PLANTER
 NTS

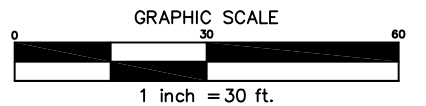

Fixture type CF-1
LED in Canopy



Fixture type CF-2
LED in Soffit



Fixture type CF-3
Wall Mounted Fixture



Fixture type CF-4
Wall Mounted Downlight



Fixture type CG-1
LED Site Lightform



Fixture type CG-2
Uplight



Fixture type CG-3
LED Accent Fixture



Fixture type CG-4
LED Linear Fixture

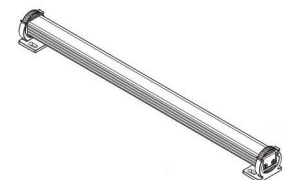

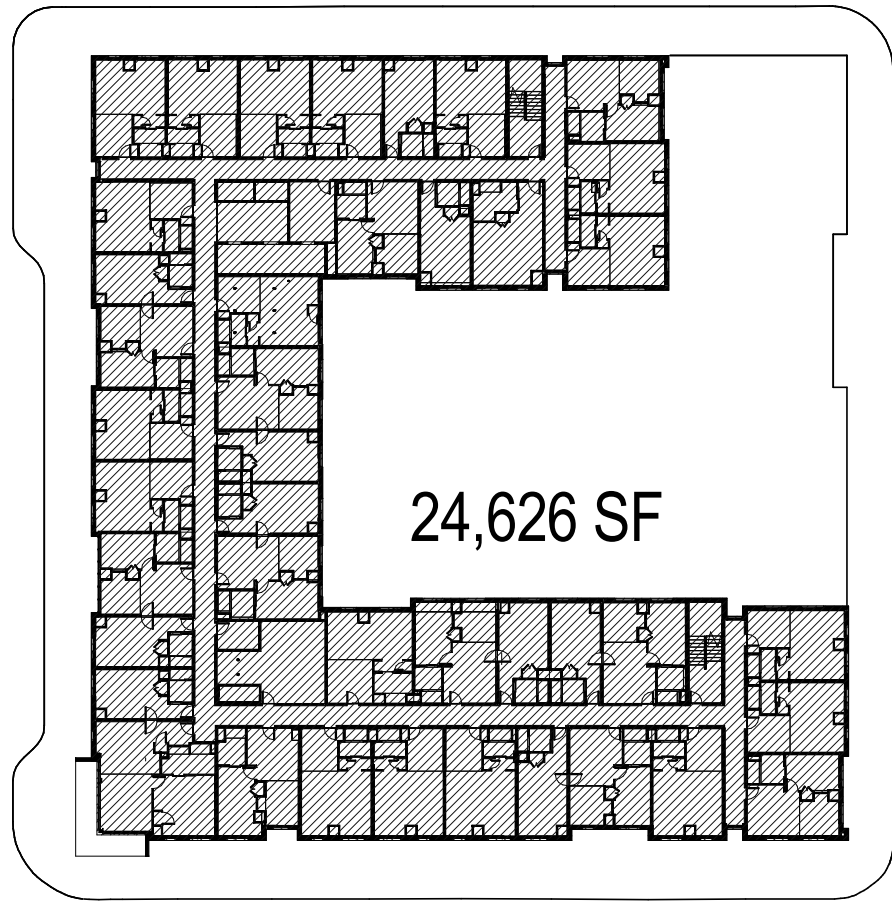

LEVEL 3 - LEVEL 6

1" = 50'-0"

3

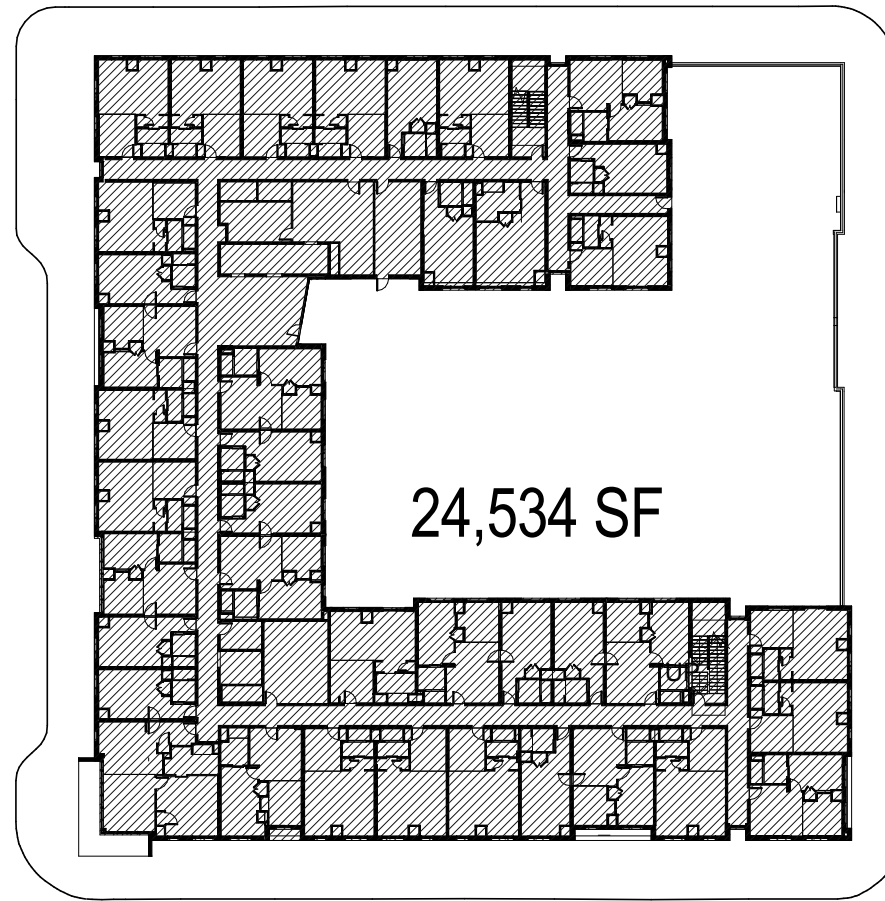

LEVEL 2

1" = 50'-0"

2

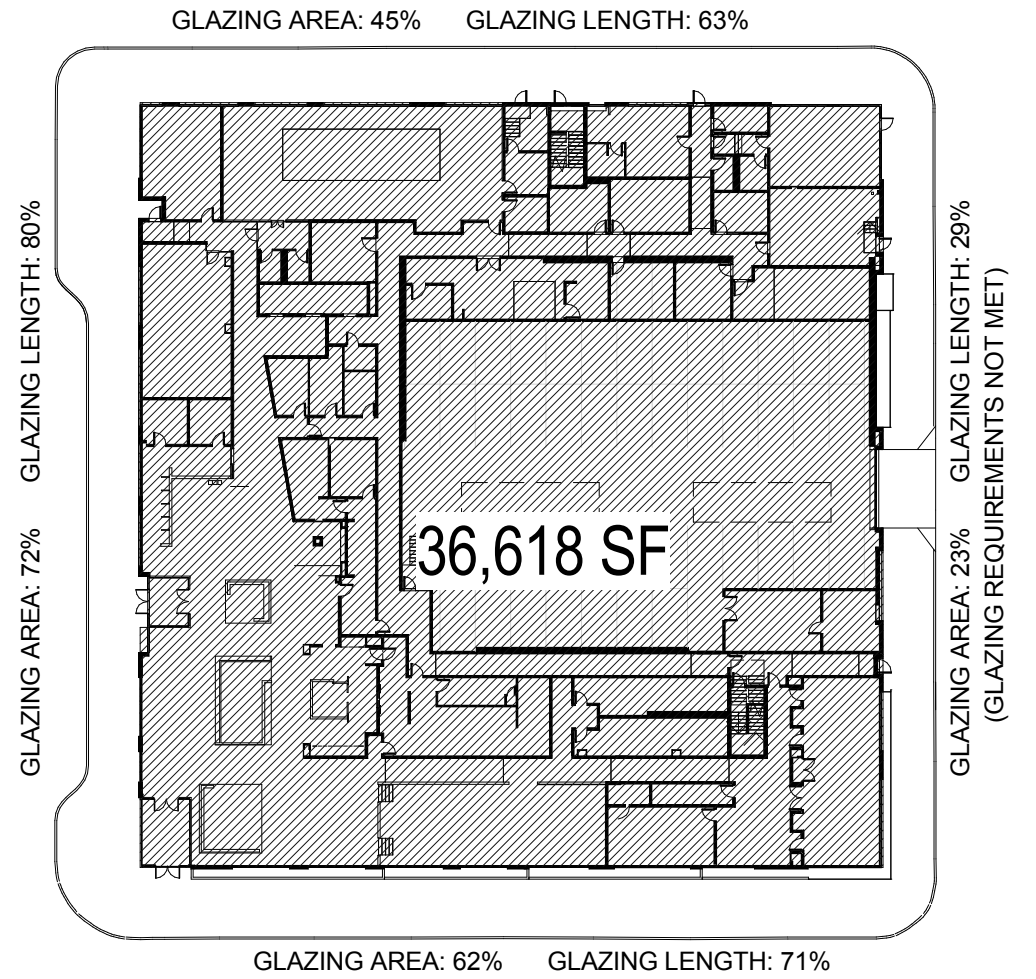

LEVEL 1

1" = 50'-0"

1

MINT URBAN APARTMENTS

SW RIVER DRIVE

THE STRAND

SW HALL STREET

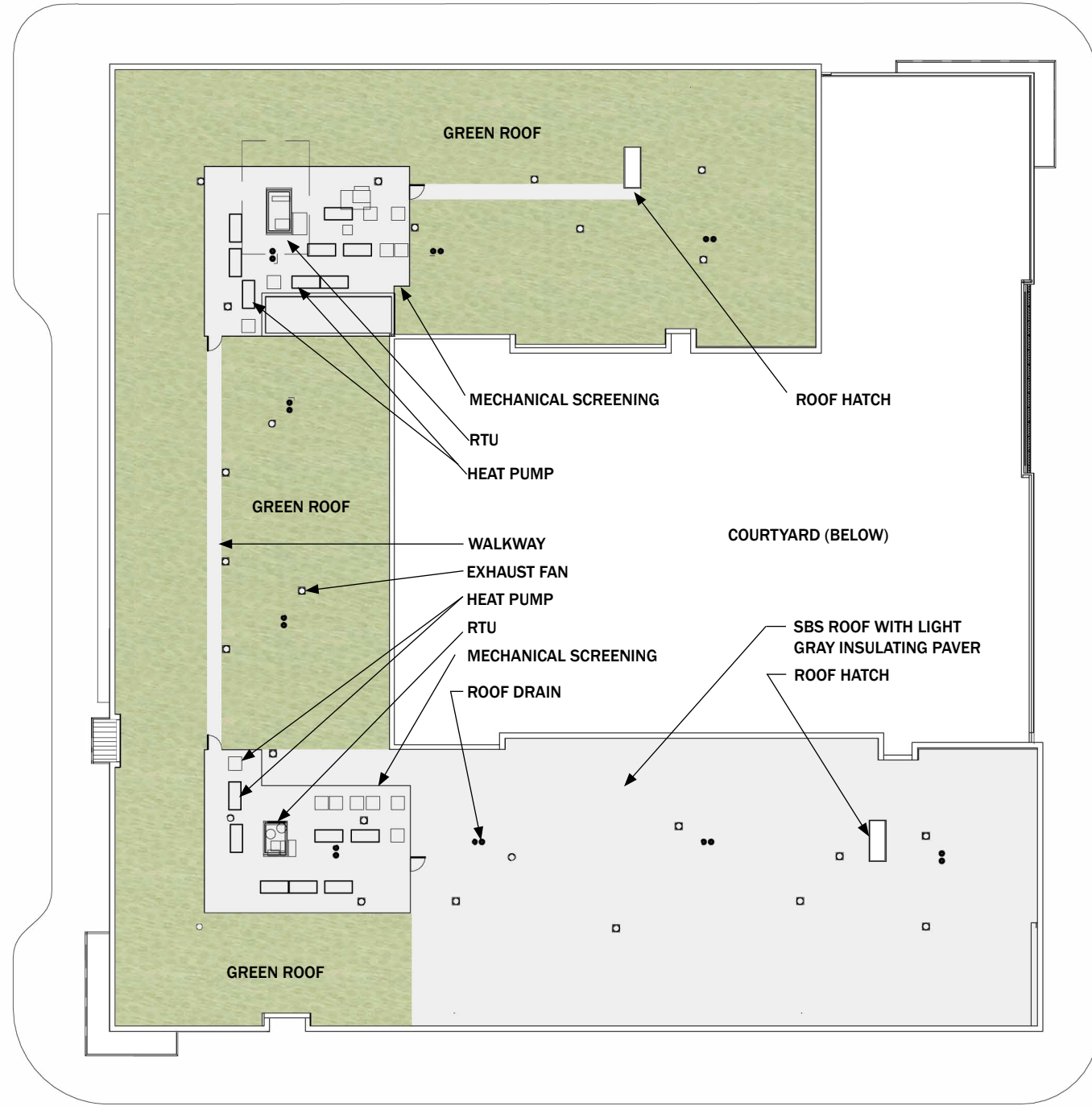

SW MOODY AVE

DAVID EVANS AND ASSOCIATES

SW RIVER PARKWAY



SOUTH ELEVATION



WEST ELEVATION



EAST ELEVATION



NORTH ELEVATION



SLATE VENEER

MECHANICAL SCREEN VERTICAL SEAM
METAL PANEL, SLATE GREY COLOR

1/3 BOND, NORMAN SIZE BRICK, GRANITE COLOR

FIBERGLASS WINDOW, SLATE GREY COLOR FRAME

FLAT-LOCK PRE-WEATHERED ZINC PANEL,
ZINC COLOR

ALUMINUM STOREFRONT SYSTEM,
SLATE GREY COLOR

NORTH ELEVATION COURTYARD

EAST ELEVATION COURTYARD

SOUTH ELEVATION COURTYARD



SOUTH ENLARGED ELEVATION 3
1/8" = 1'-0"

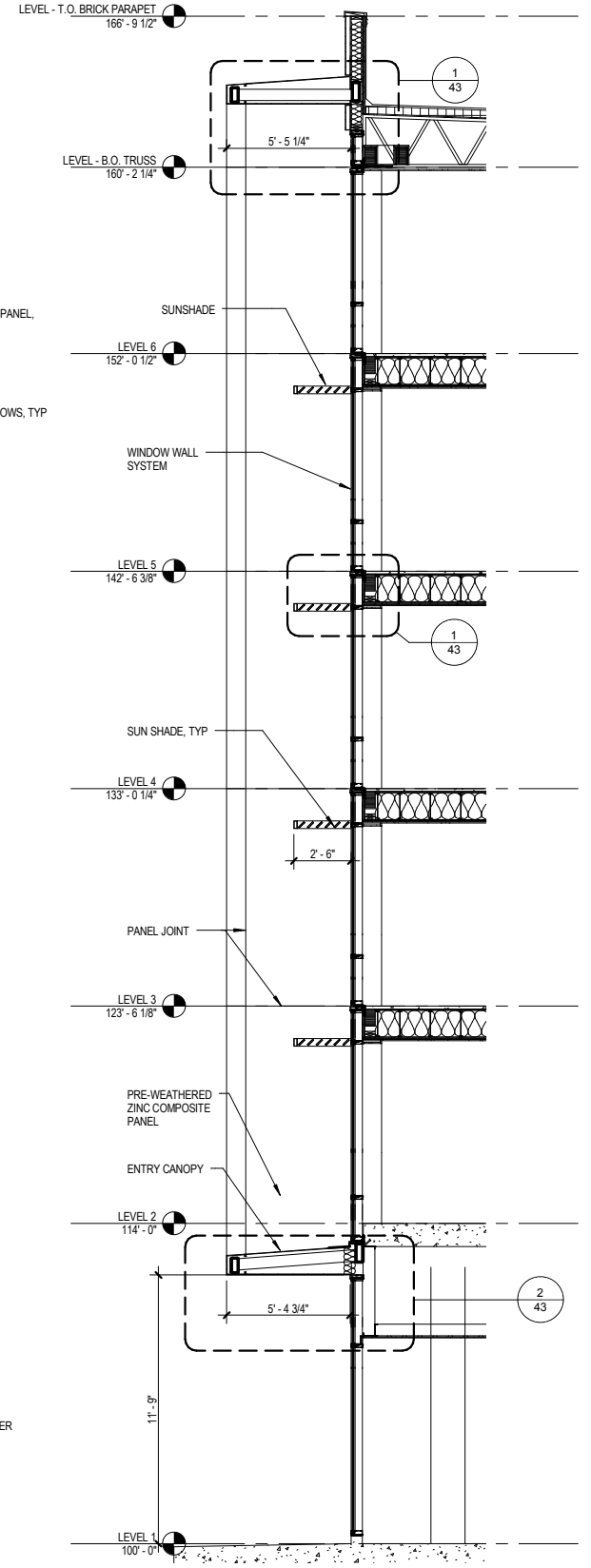

SECTION @ CURTAINWALL 2
1/8" = 1'-0"

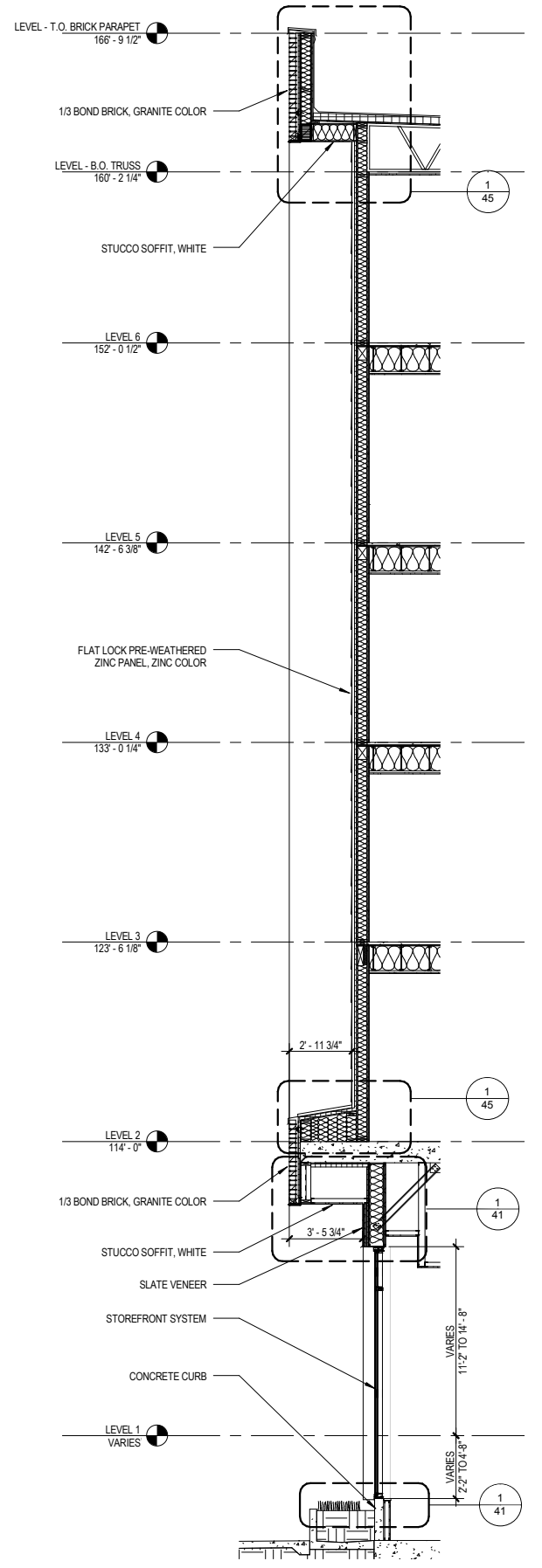

SECTION @ RECESS 1
1/8" = 1'-0"



TYPICAL RECESSED BAY ENLARGED 3
1/8" = 1'-0"

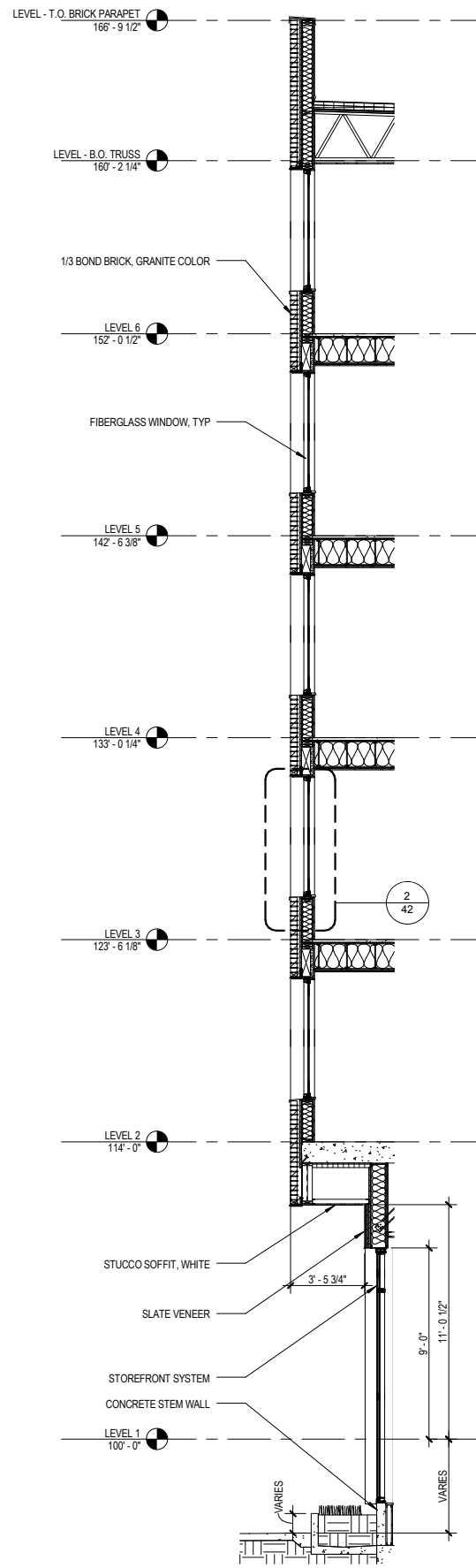

SECTION @ BRICK 2
1/8" = 1'-0"

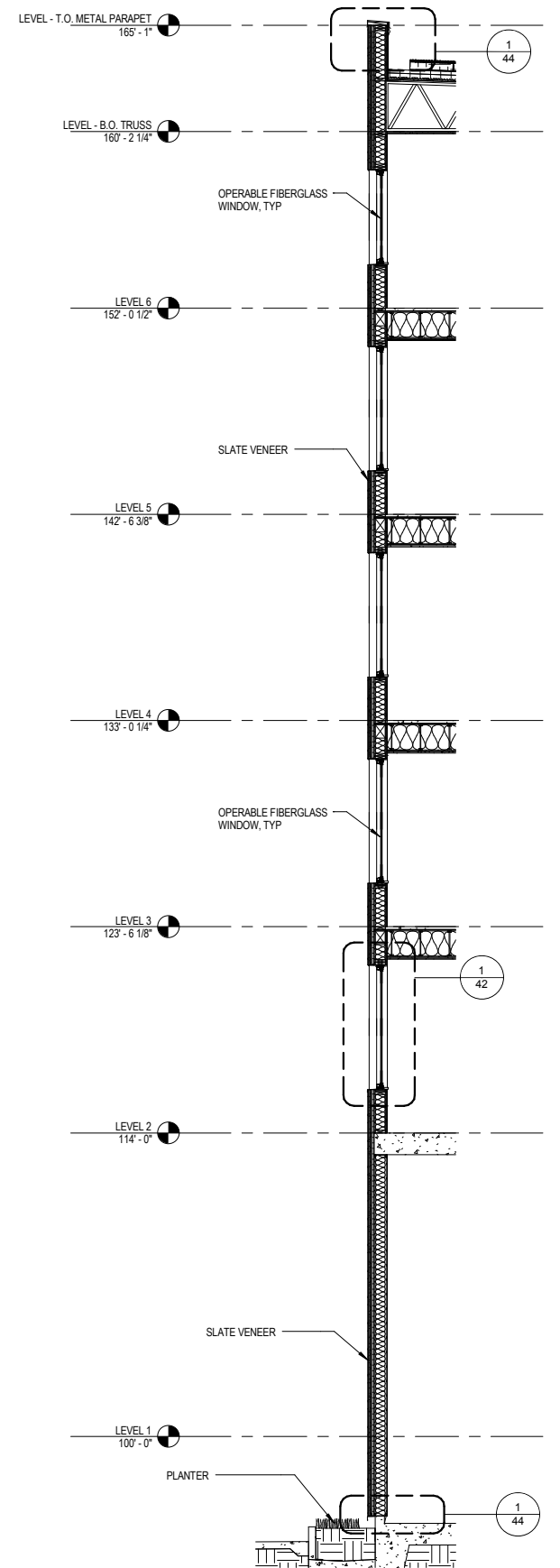

SECTION @ SLATE 1
1/8" = 1'-0"



WEST ENTRY ELEVATION 1
1/8" = 1'-0"

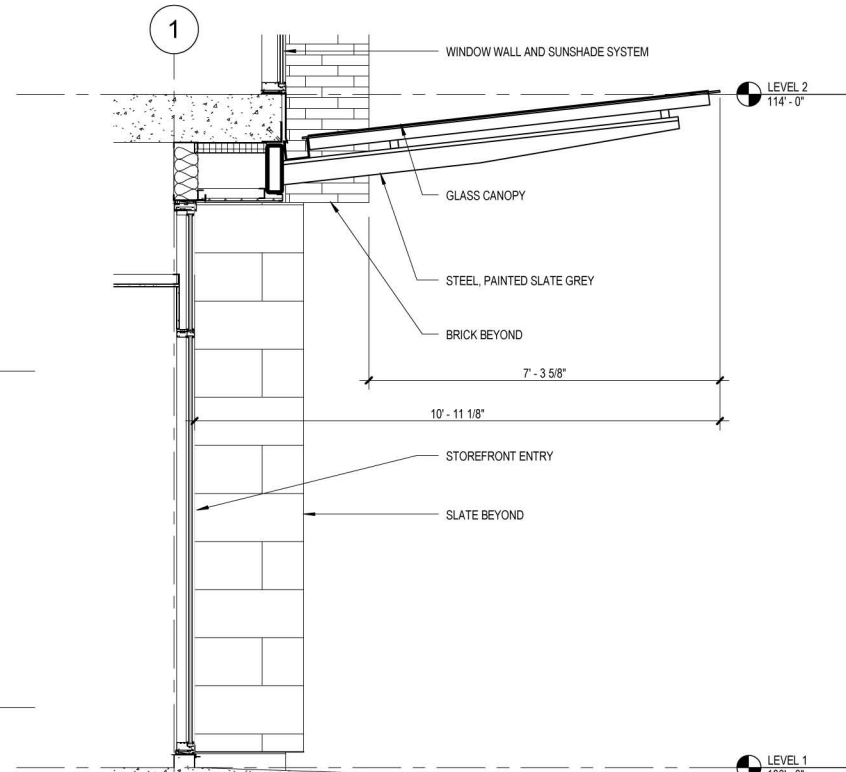

WEST CANOPY ENTRY 2
1/4" = 1'-0"

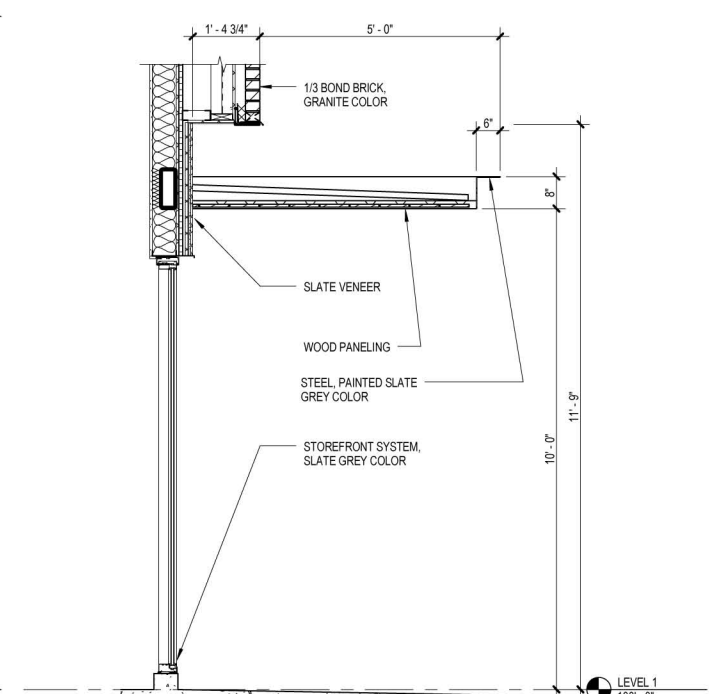

WEST CANOPY 3
1/4" = 1'-0"

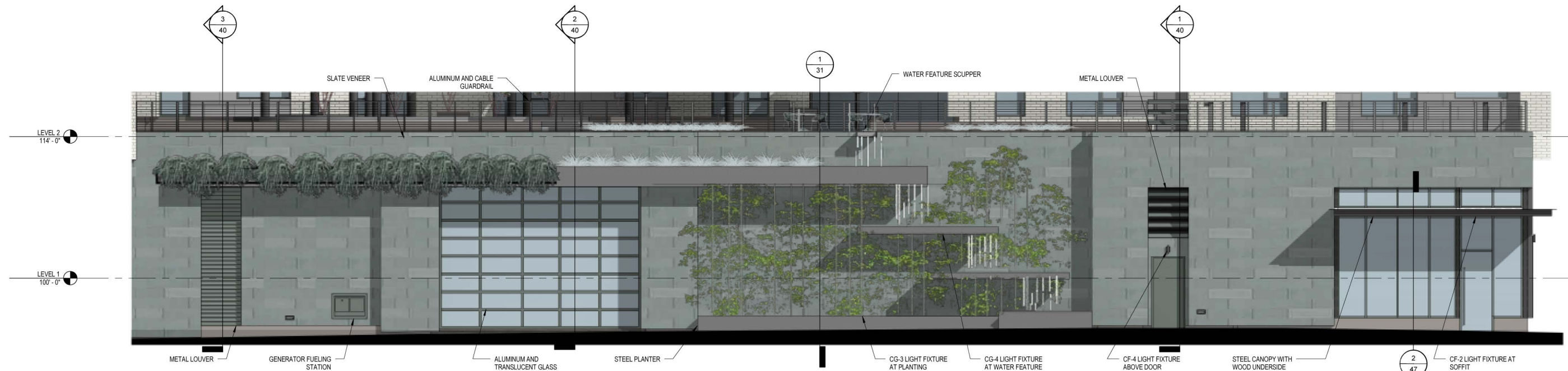

PLANTER WALL ELEVATION 4
3/32" = 1'-0"





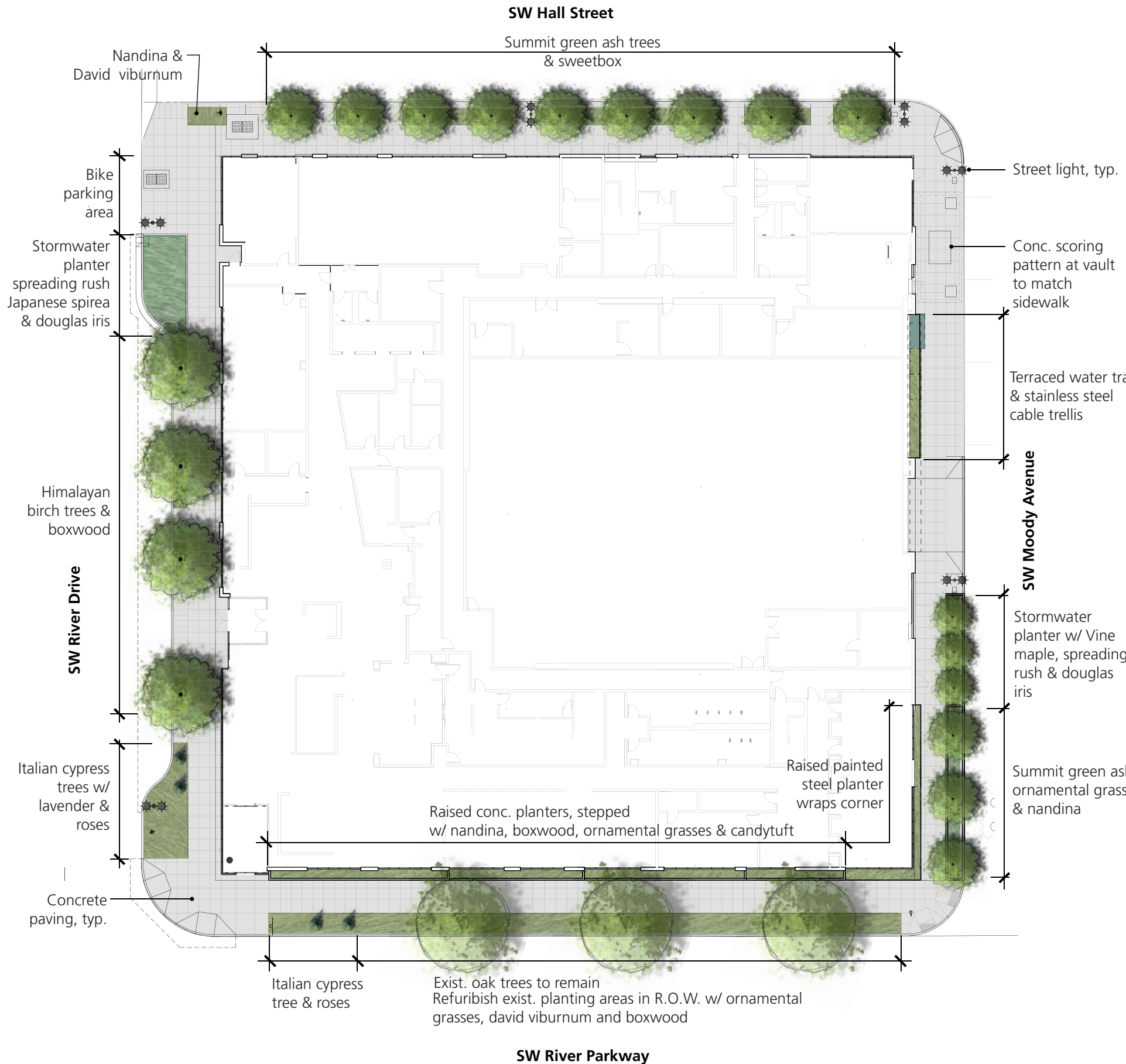

SE River Drive



SW Entry



SE River Parkway



SW Moody



SW Hall



Trellis Planter



Stormwater planters





- Italian cypress tree
- Concrete raised planter, stepped, typ.
- Exist. tree to remain & refurbished planting area (plants proposed in R.O.W. not shown for clarity), typ.
- Painted steel raised planter, wraps corner

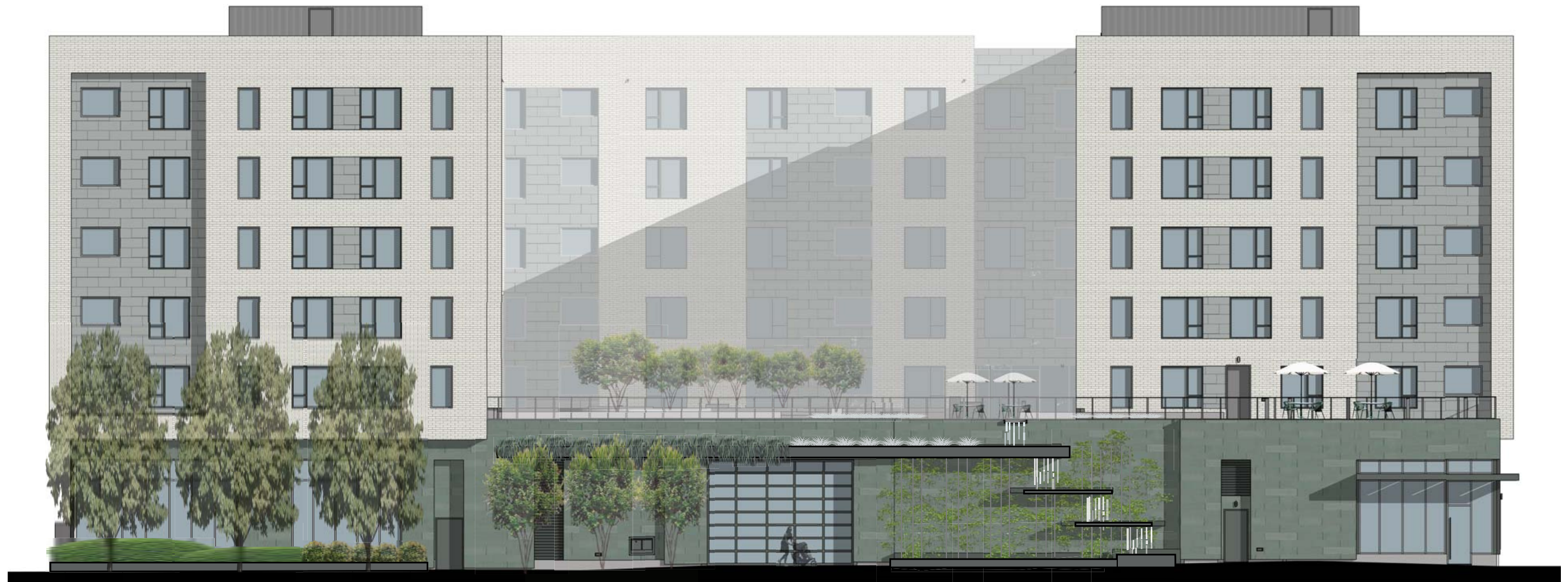

/ Low shrubs in painted steel planter
 Street trees shown in front
 Understory plantings not shown for clarity

/ Street trees shown in front
 Stormwater plantings not shown
 for clarity

/ Terraced water trays
 Vines in painted steel planter
 Stainless steel cable trellis

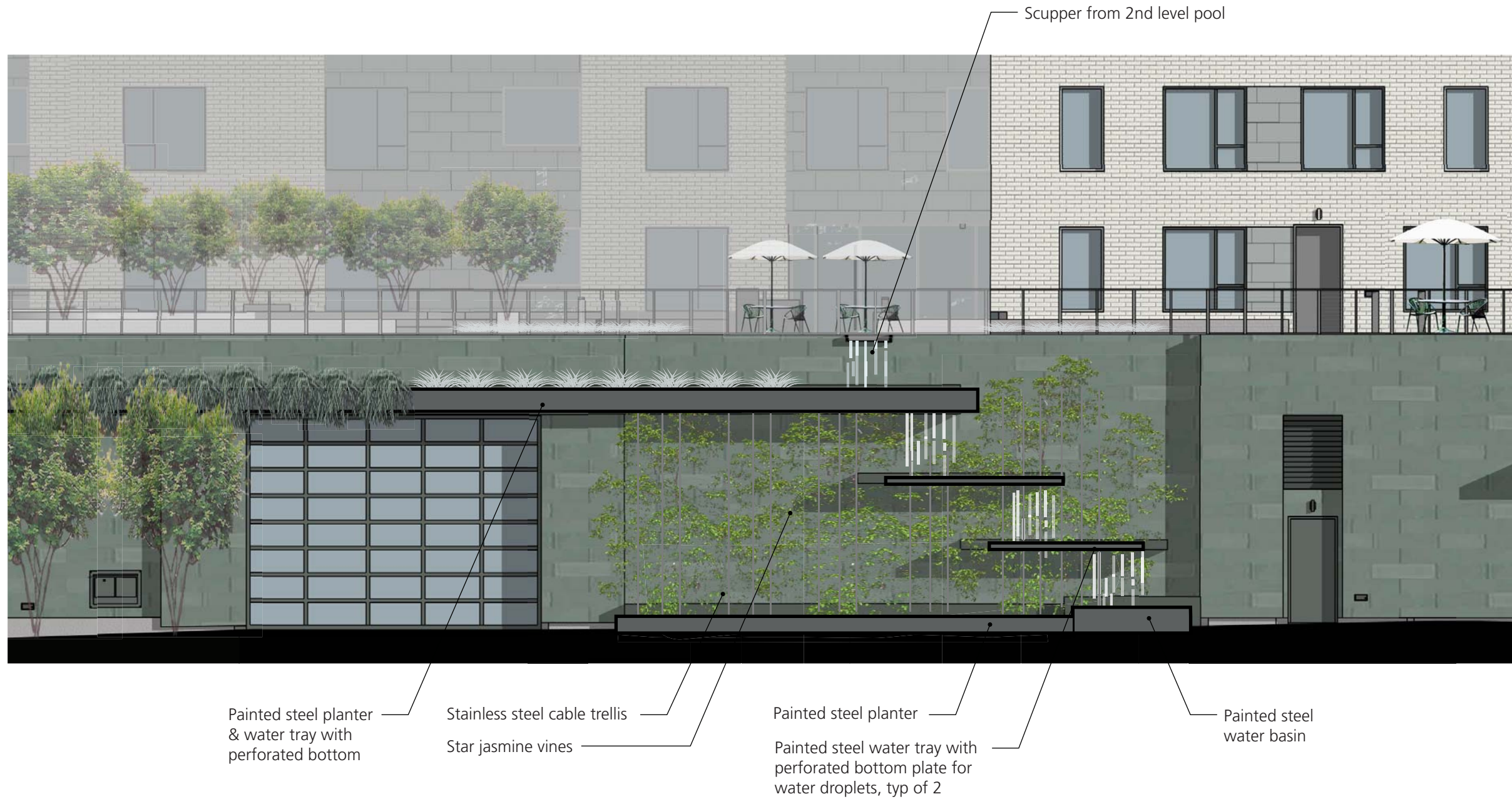

Scupper from 2nd level pool

Painted steel planter & water tray with perforated bottom

Stainless steel cable trellis
Star jasmine vines

Painted steel planter
Painted steel water tray with perforated bottom plate for water droplets, typ of 2

Painted steel water basin



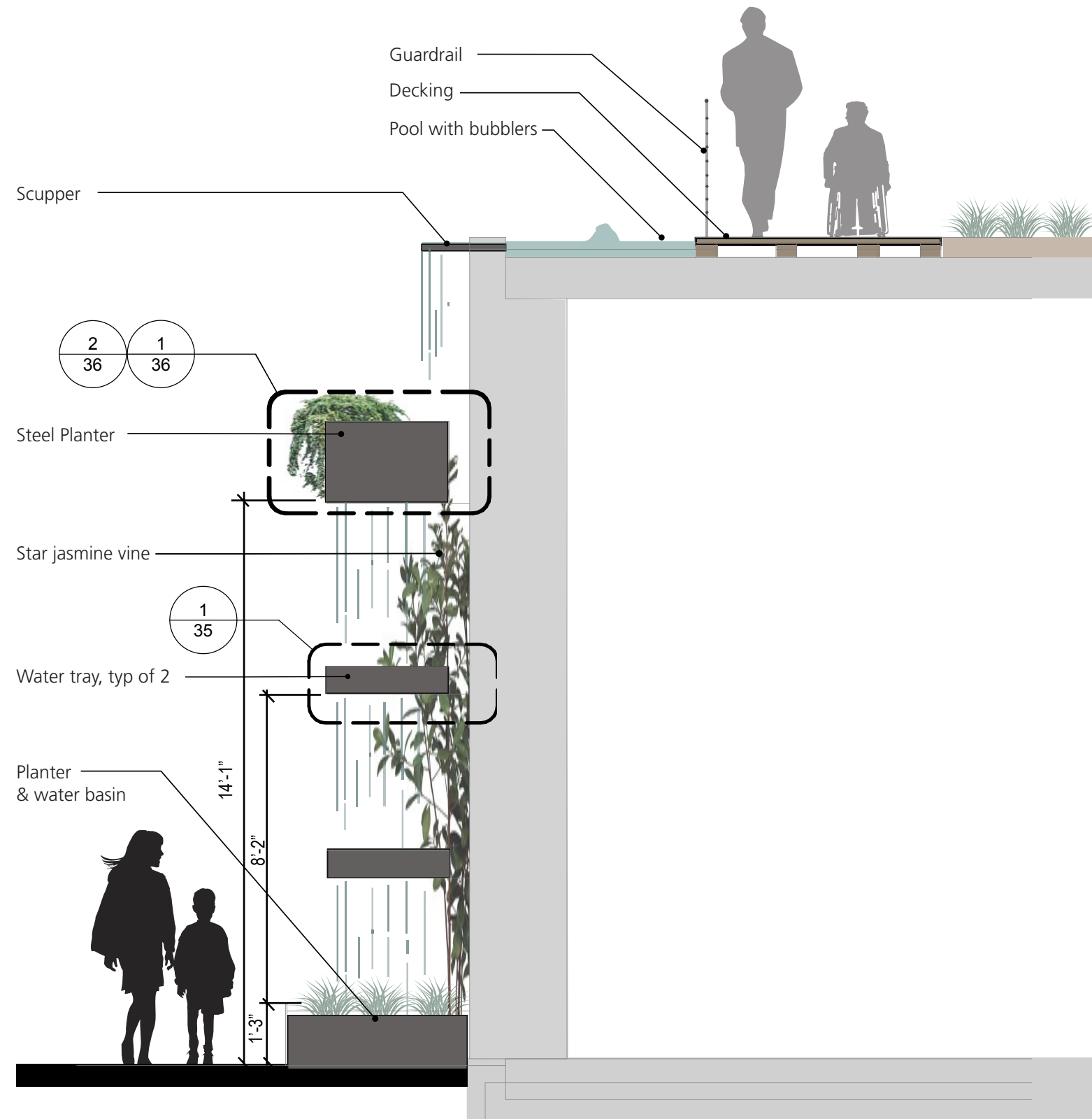

2nd Level



Street Level

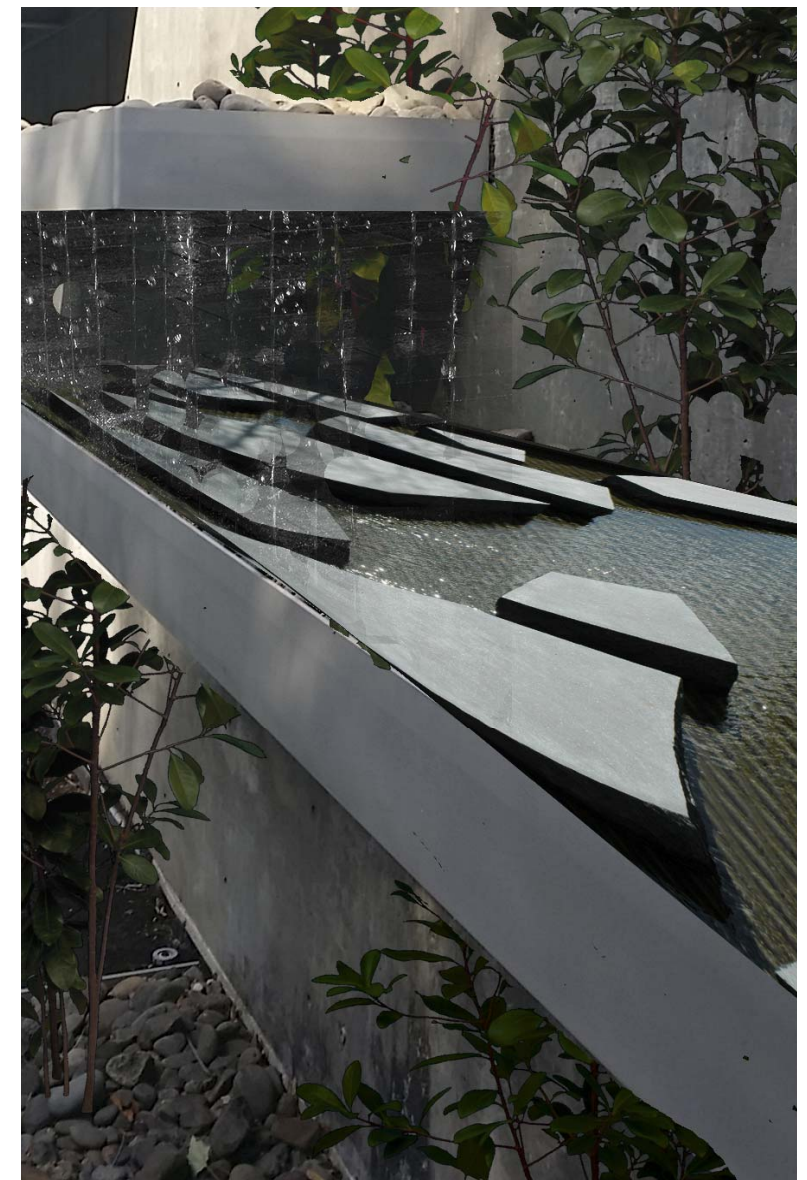





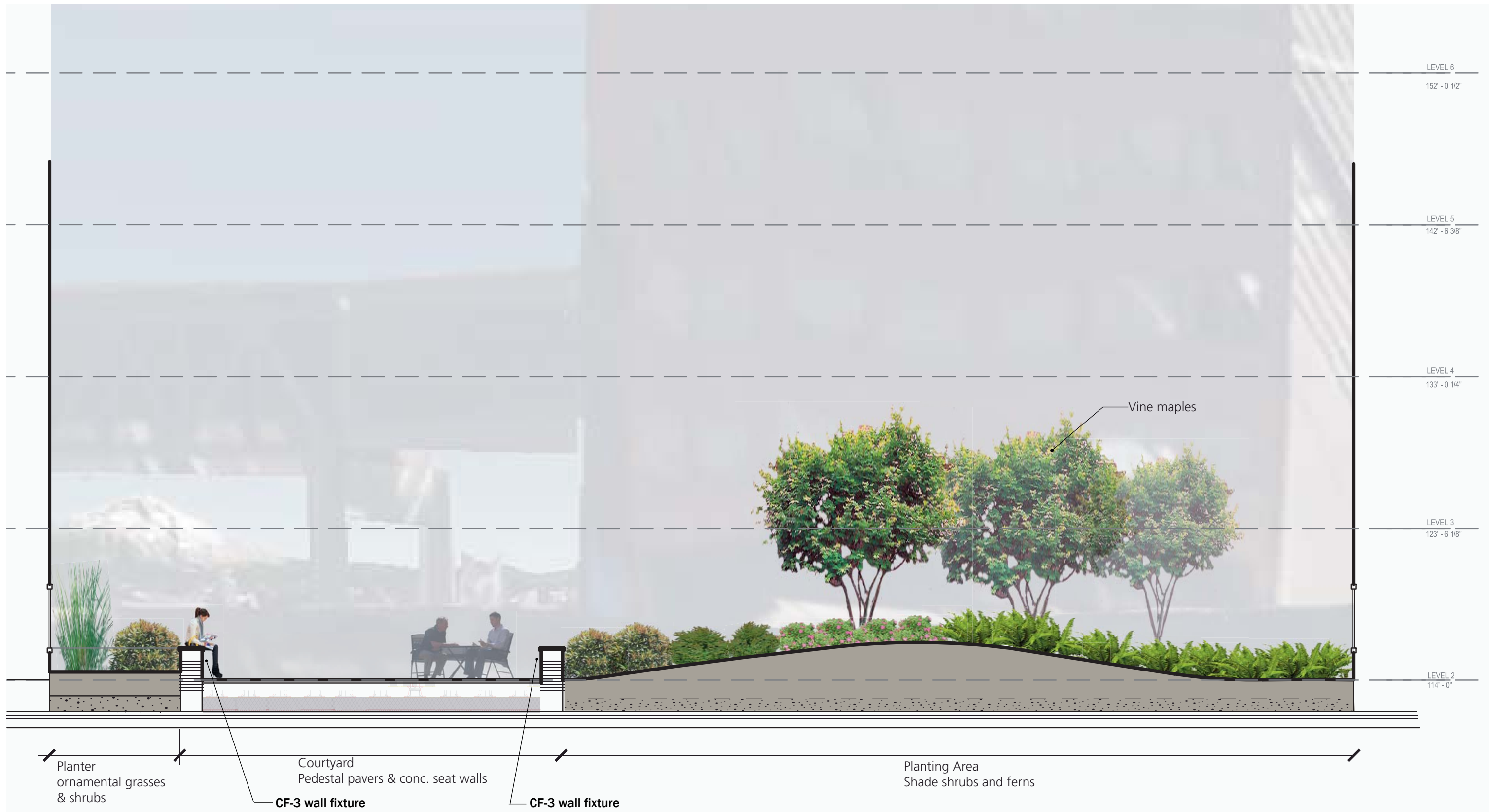

Painted steel frame, basalt stone over corrugated mat and water

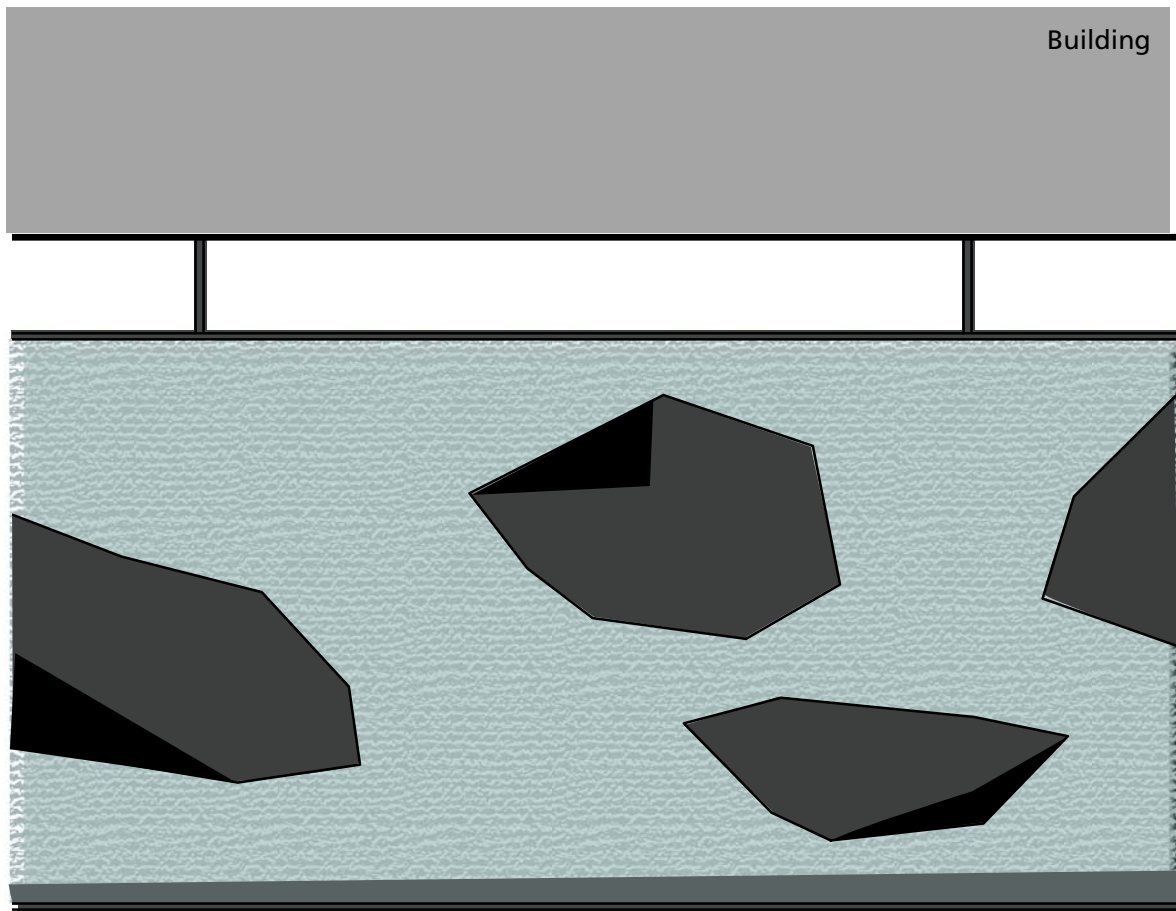
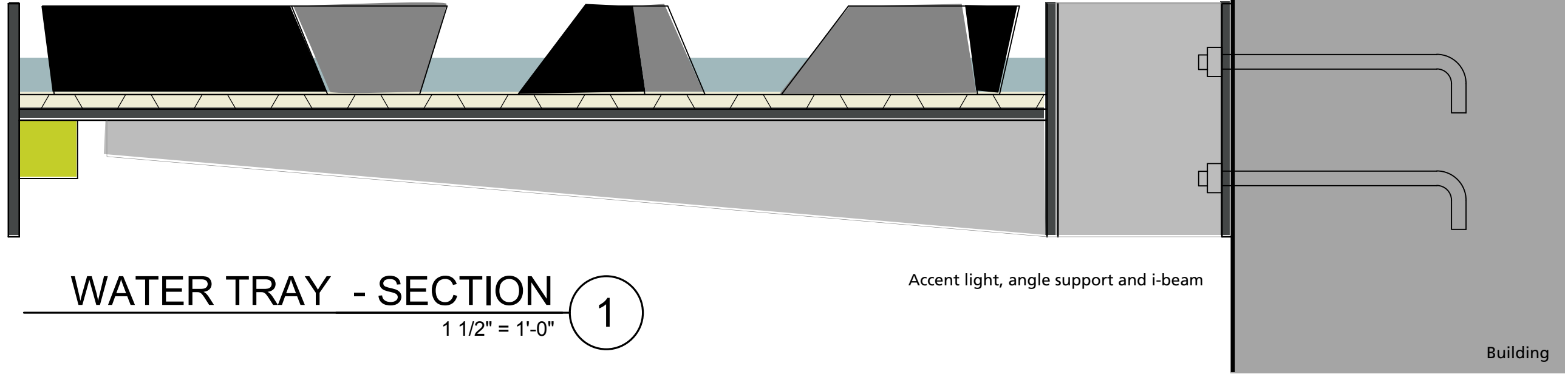

Water Tray - Top View
1" = 1'-0"

Polished Basalt and water

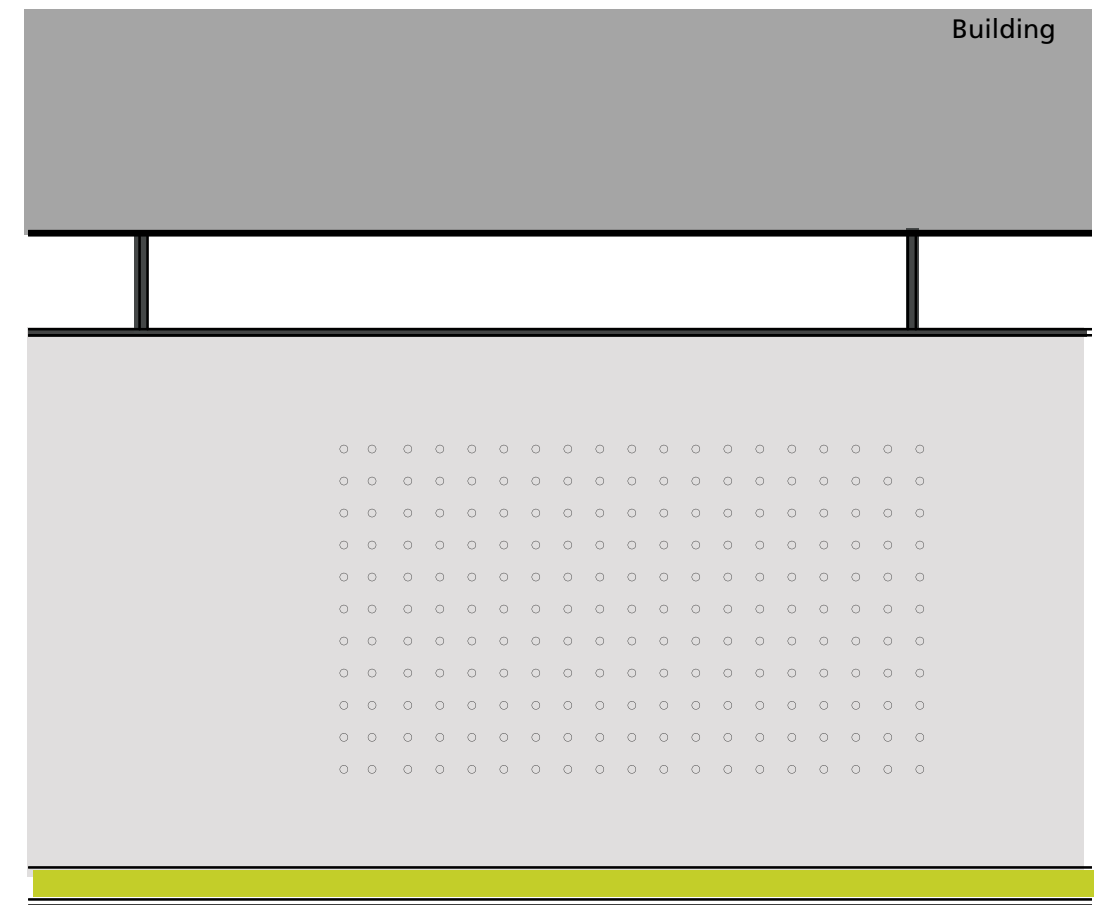

Water Tray - Bottom View
1" = 1'-0"

Drilled perforation and linear accent light

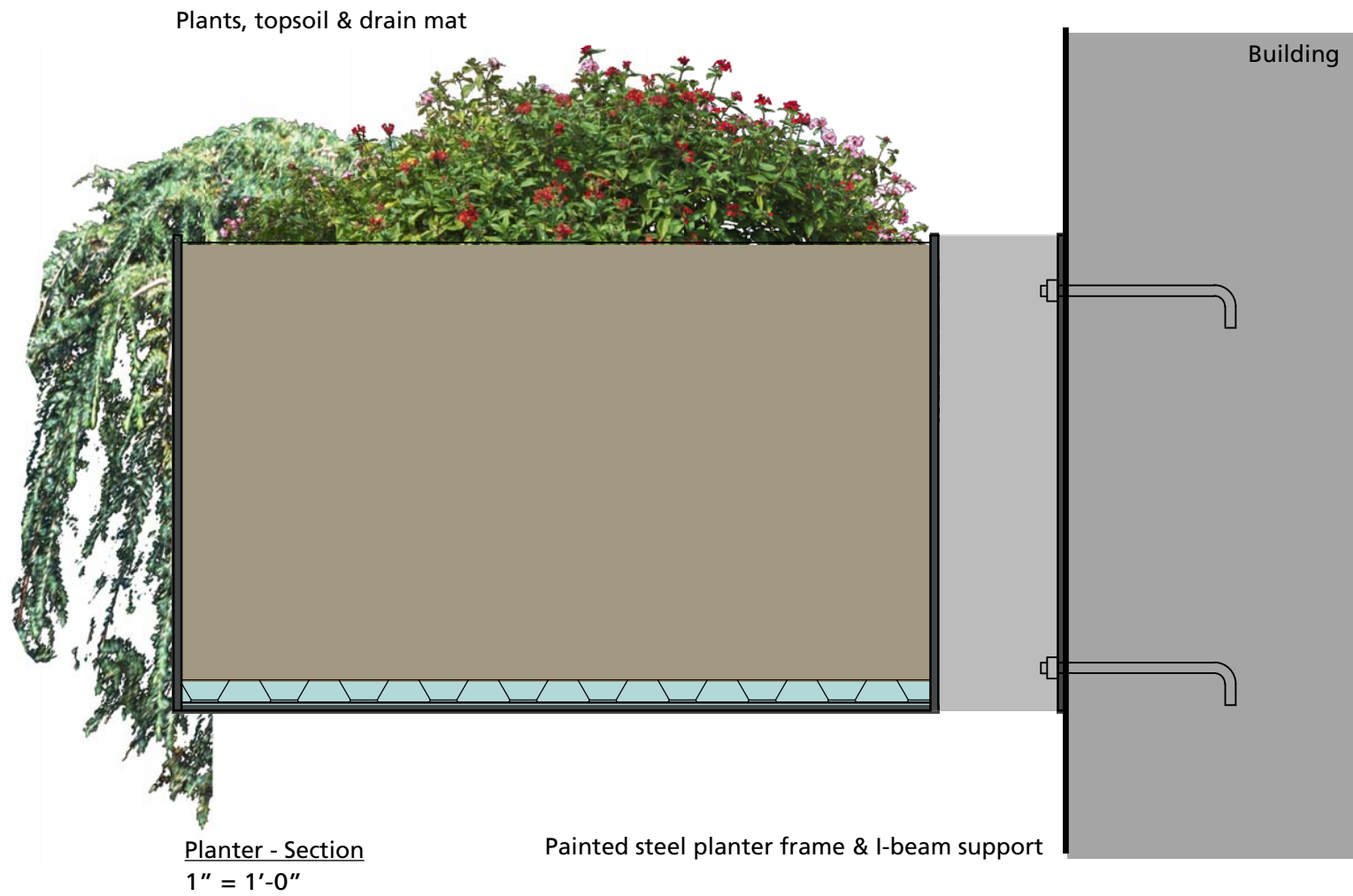

PLANTER - SECTION

1" = 1'-0"

1

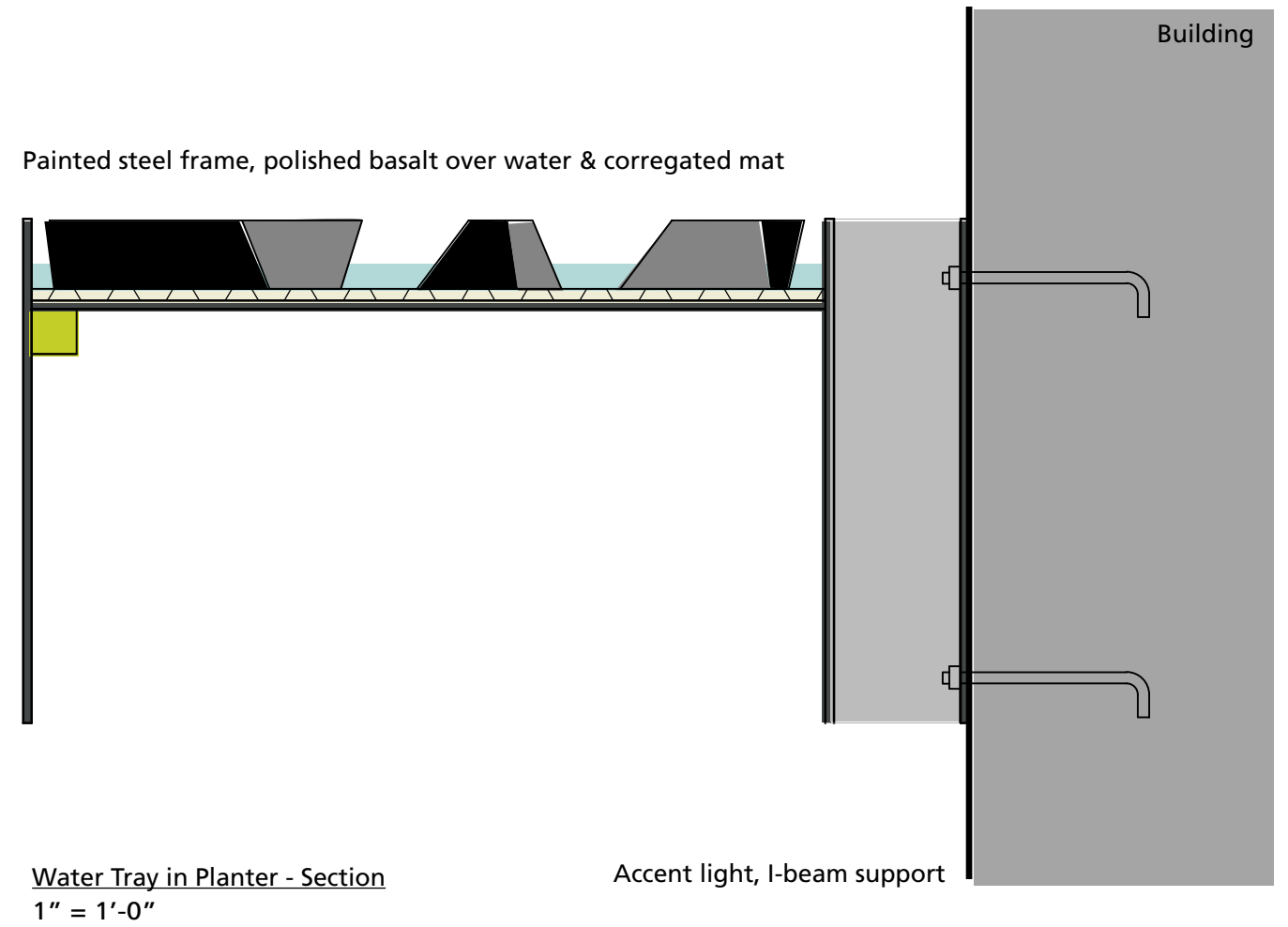

WATER TRAY - SECTION

1" = 1'-0"

2

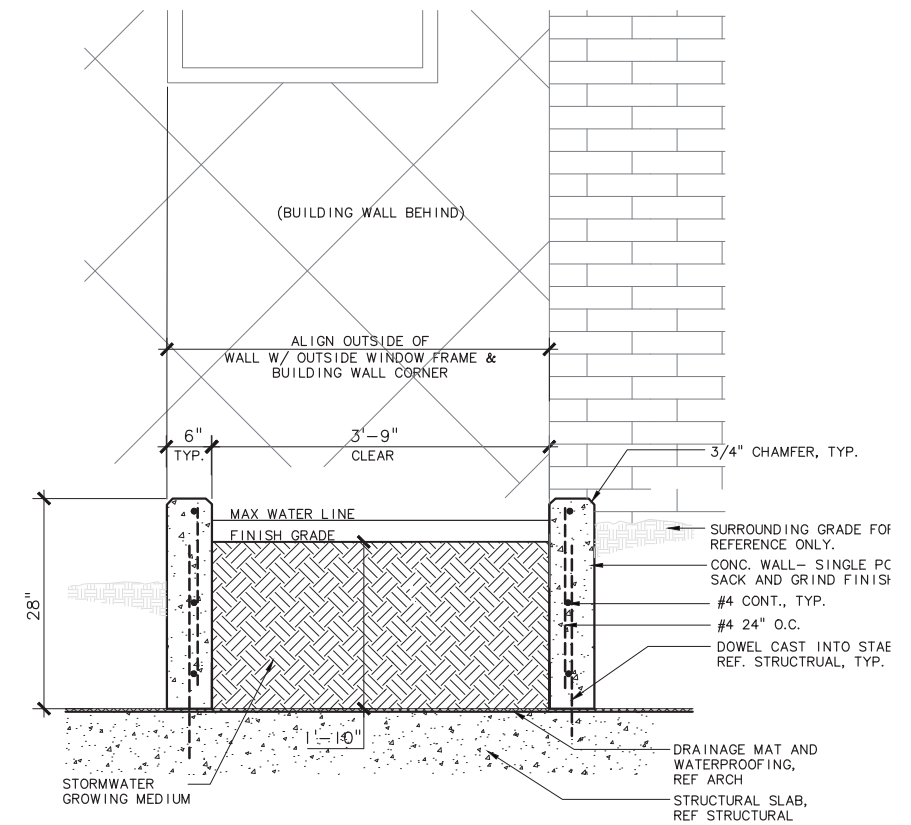
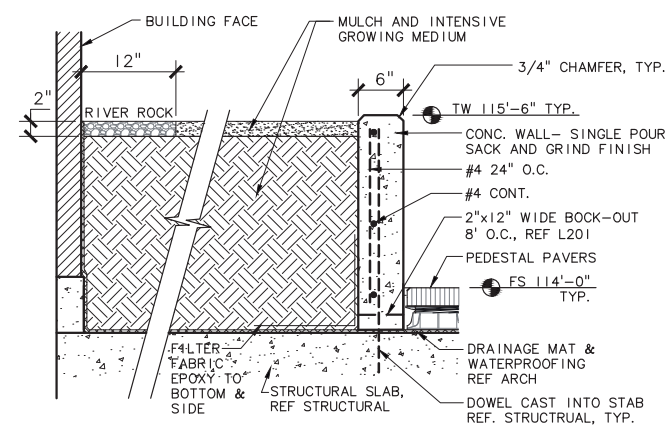
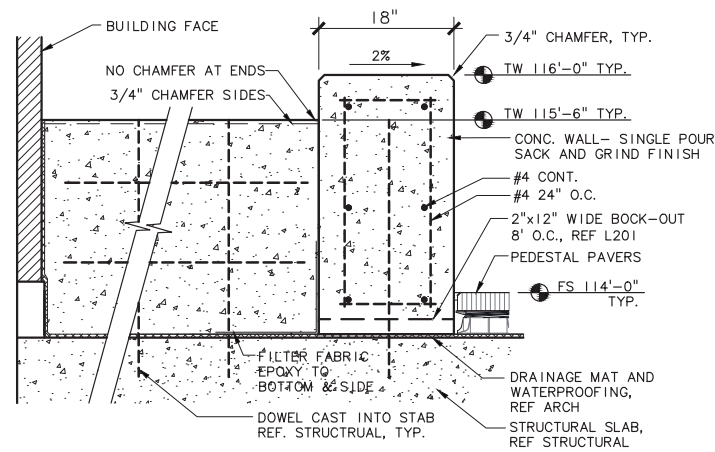

TERRACE SEAT WALL

1/2" = 1'-0"

3

TERRACE PLANTER WALL

1/2" = 1'-0"

2

TERRACE STORMWATER

1/2" = 1'-0"

1

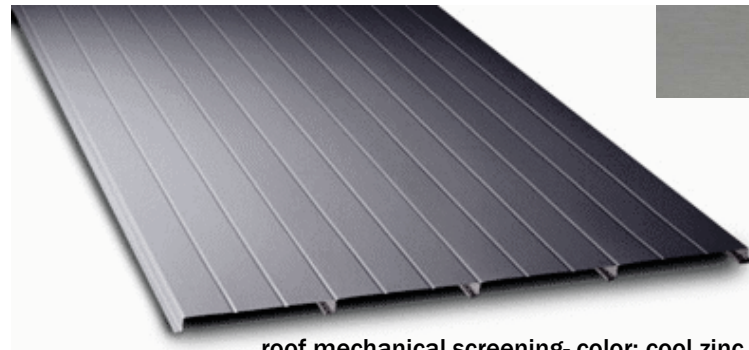

roof mechanical screening- color: cool zinc



aluminum & glass overhead door - mullion color: slate grey
glazing: translucent glass



composite metal panel -
color: preweathered zinc



flat-lock metal panel -
color: preweathered zinc



colored aluminum canopy - color: slate grey @ retail
white @ hotel entrance

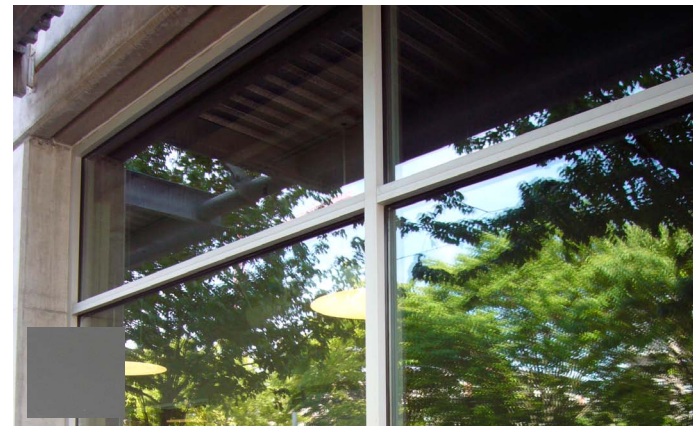

colored aluminum storefront - color: slate grey

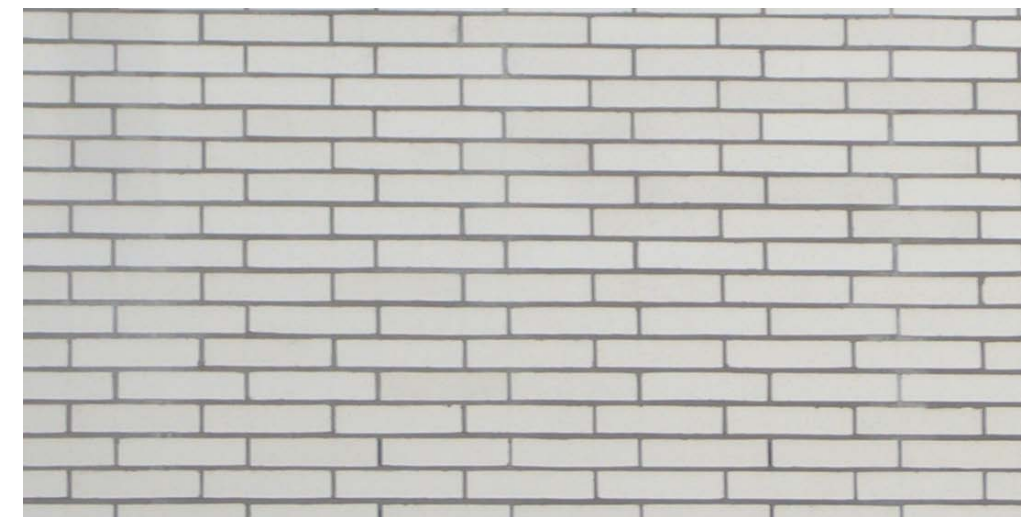

norman size brick 1/3 running bond



fiberglass window - color: slate grey



slate - Brazilian green



anodized aluminium cable rail



cast in place concrete

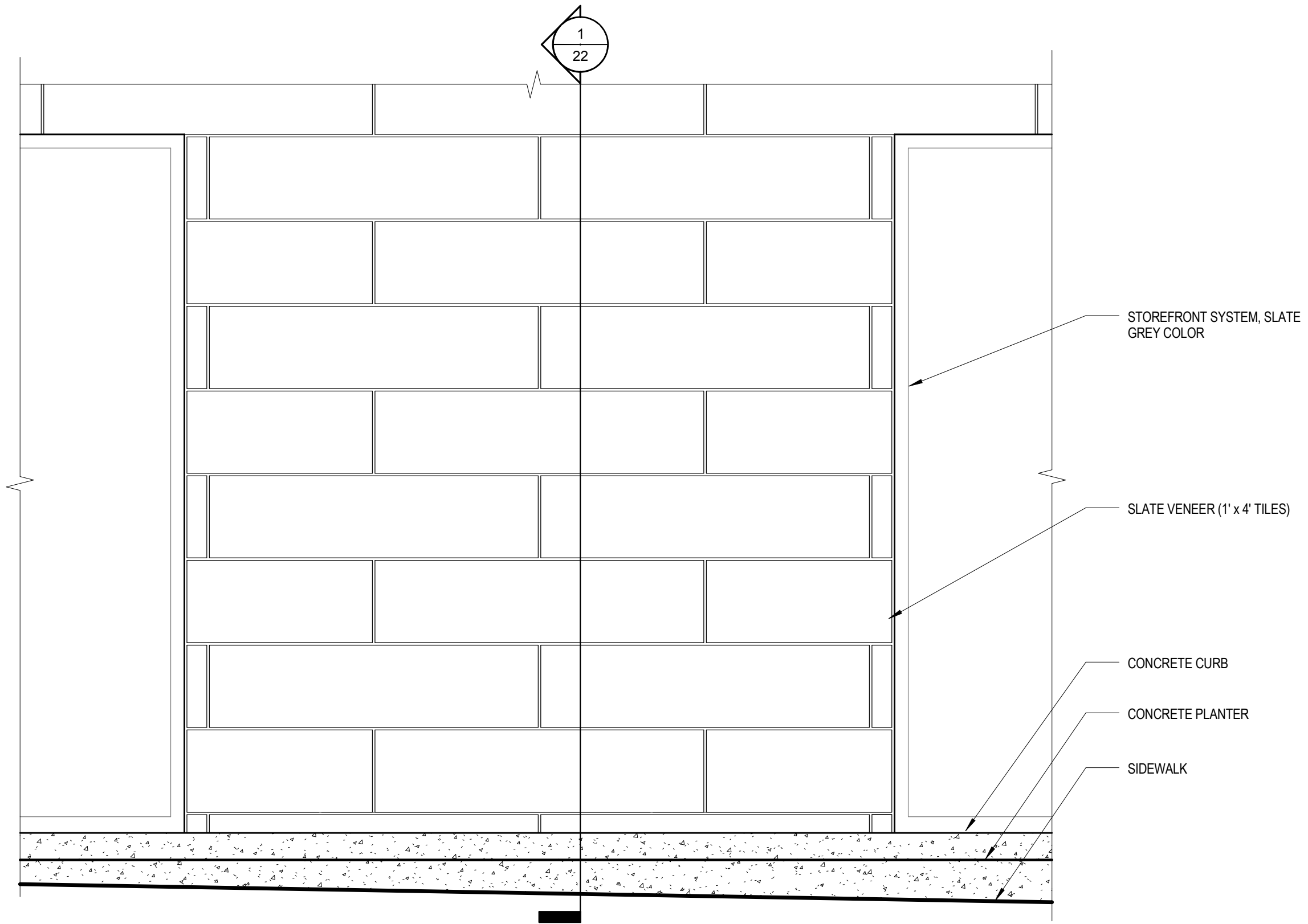

ENLARGED SLATE VENEER 1
 3/4" = 1'-0"

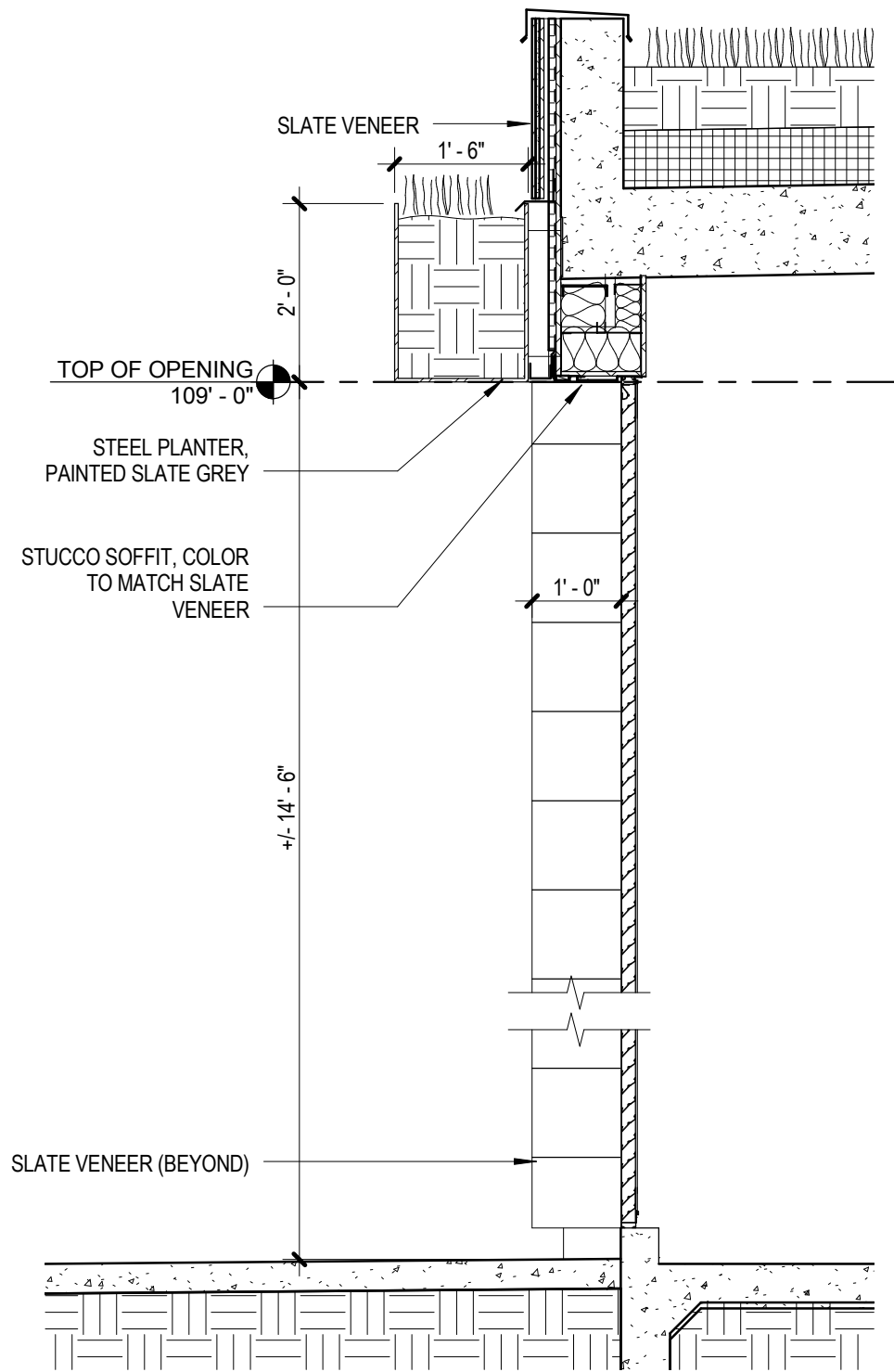

SECTION @ LOUVER (3)
1/2" = 1'-0"

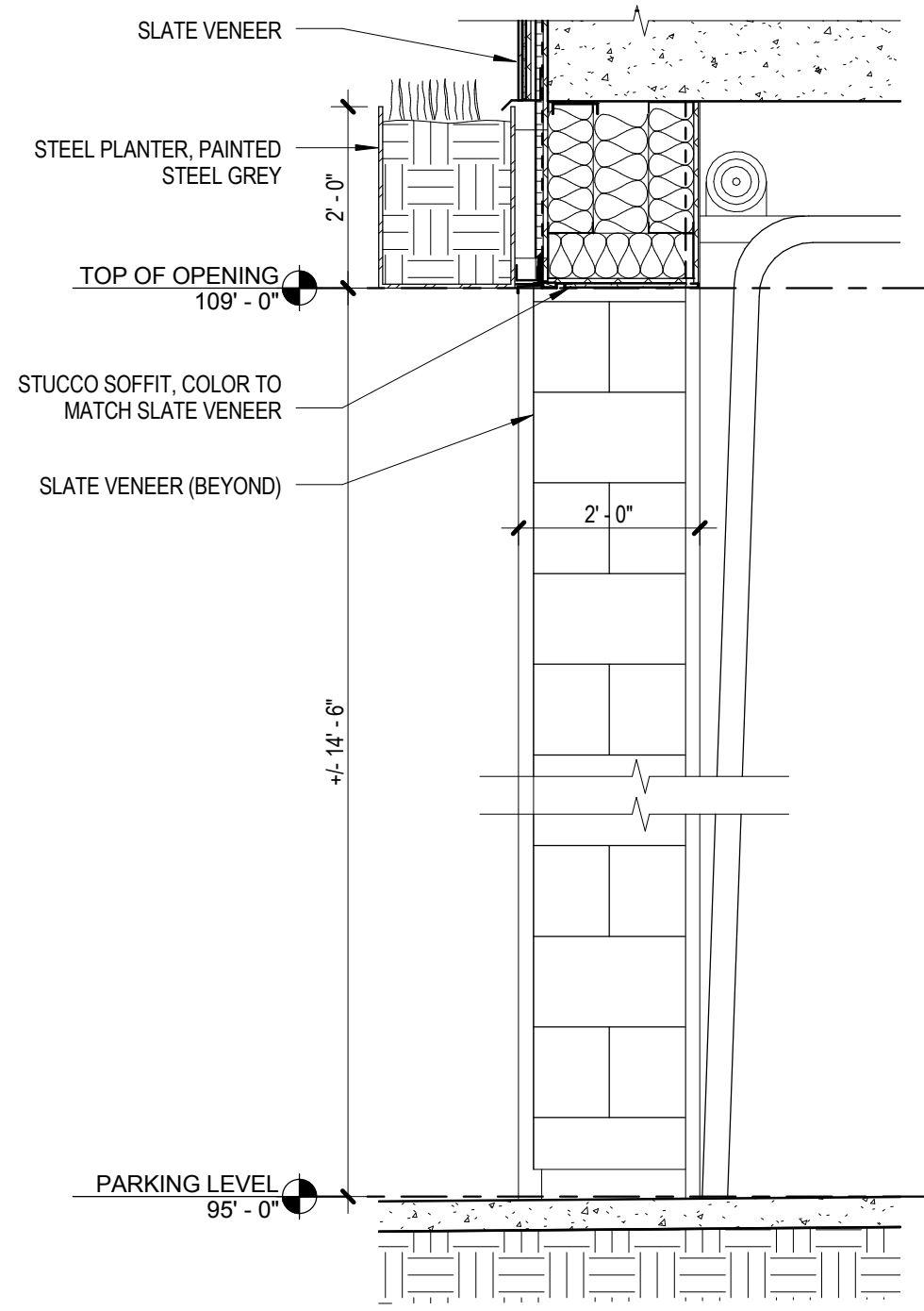

SECTION @ GARAGE ENTRY (2)
1/2" = 1'-0"

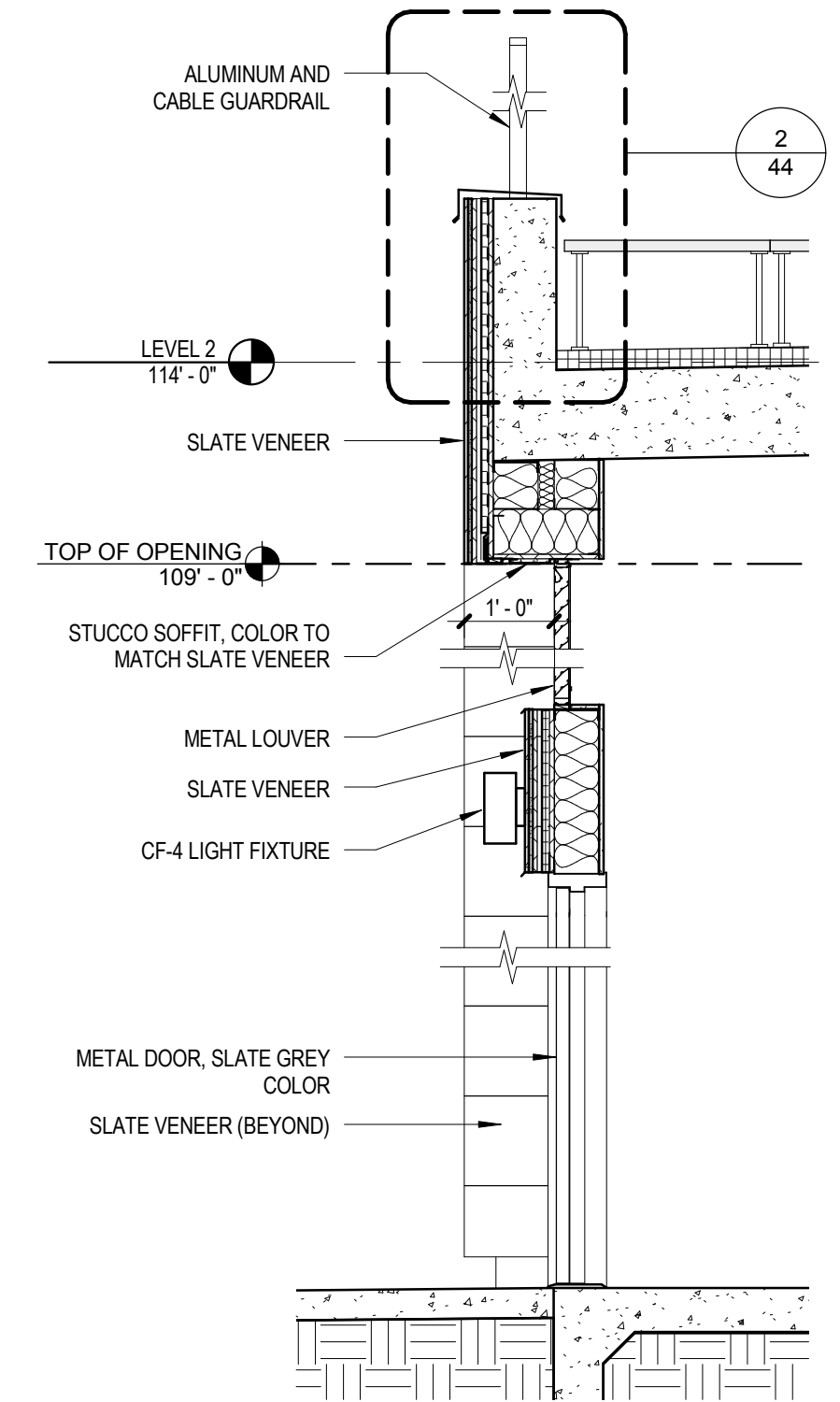

SECTION @ DOOR (1)
1/2" = 1'-0"

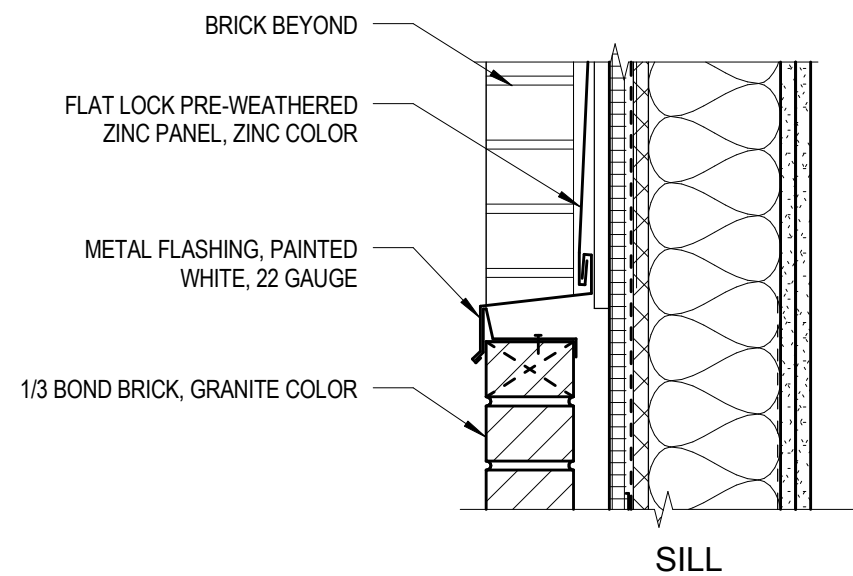
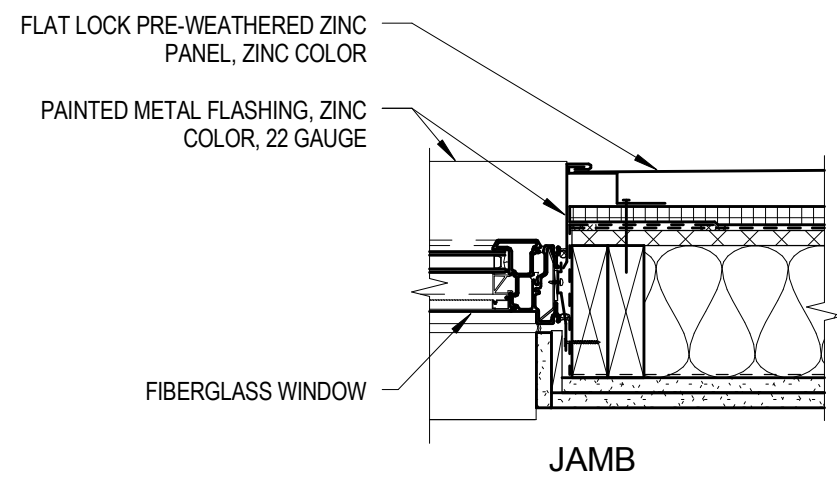
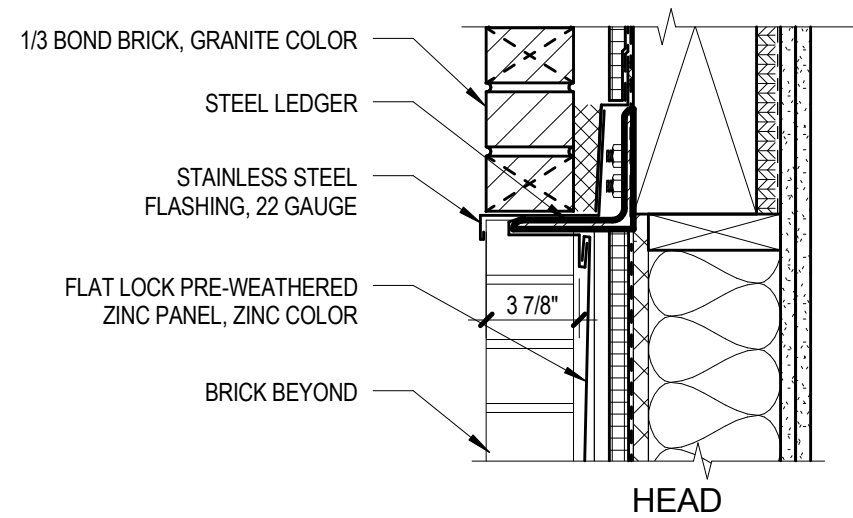

METAL PANEL @ BRICK 2
1 1/2" = 1'-0"

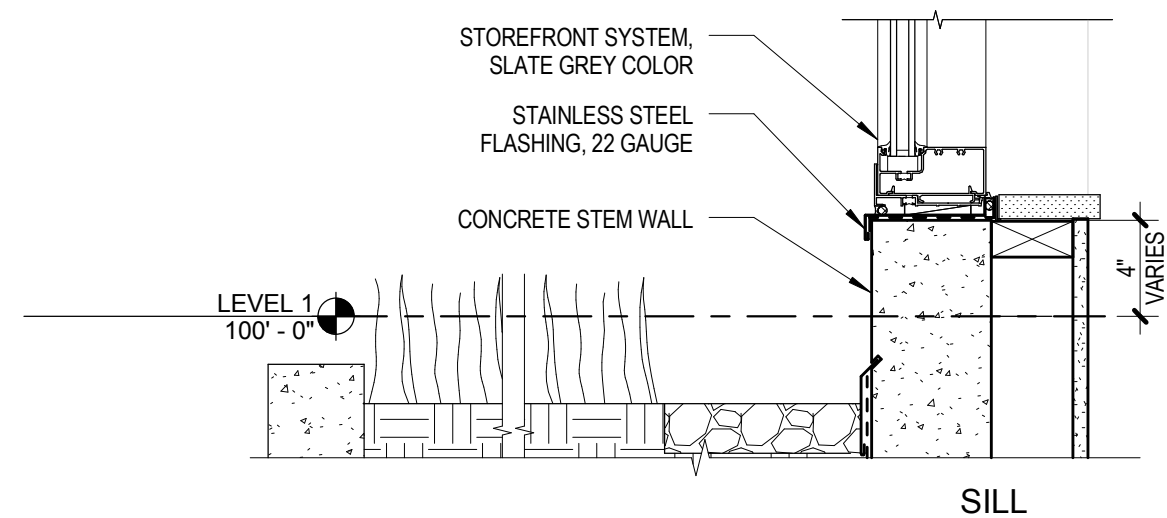
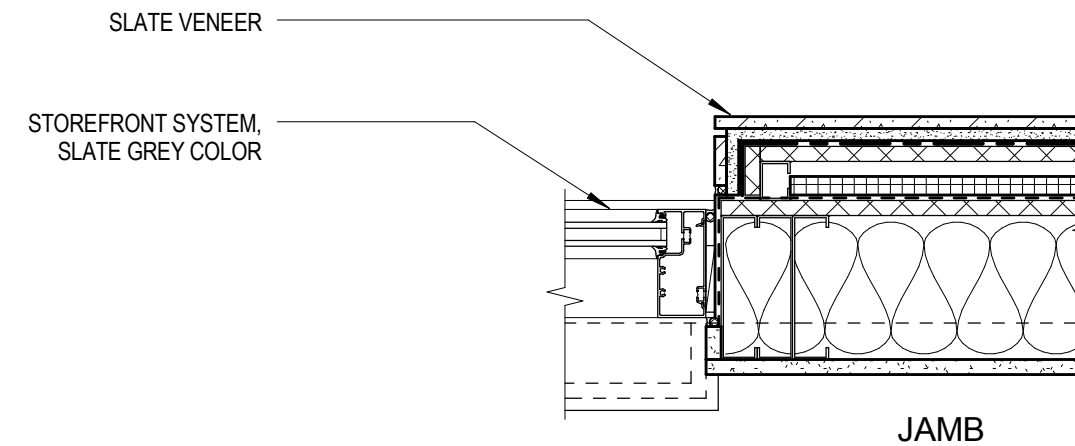
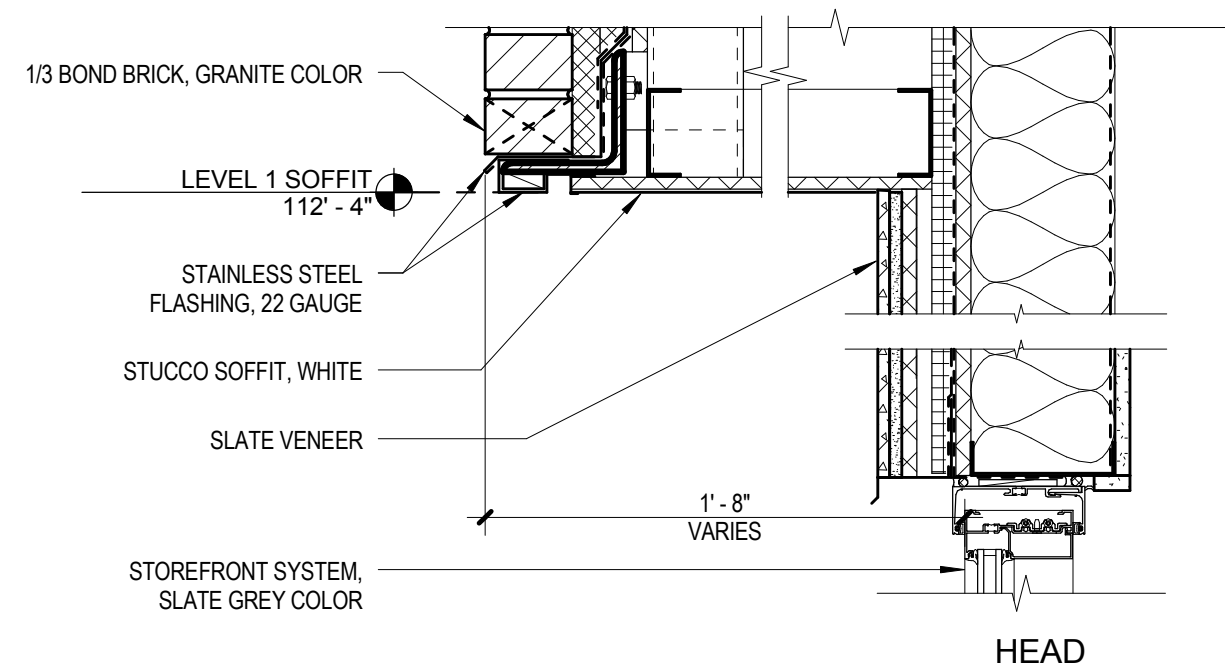

STOREFRONT DETAILS 1
1 1/2" = 1'-0"

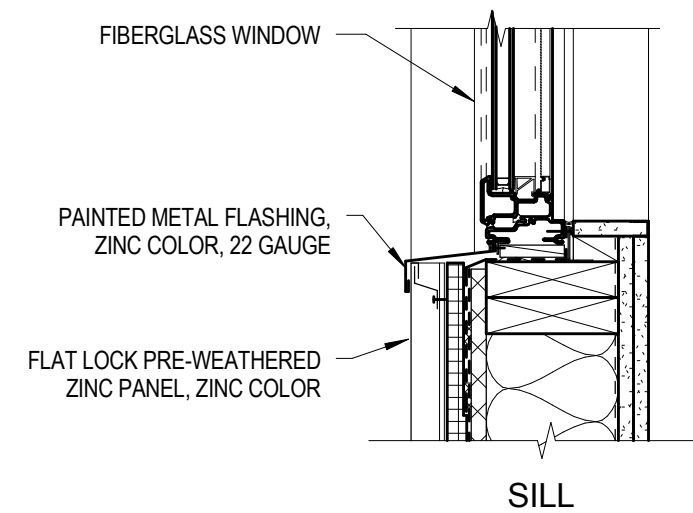
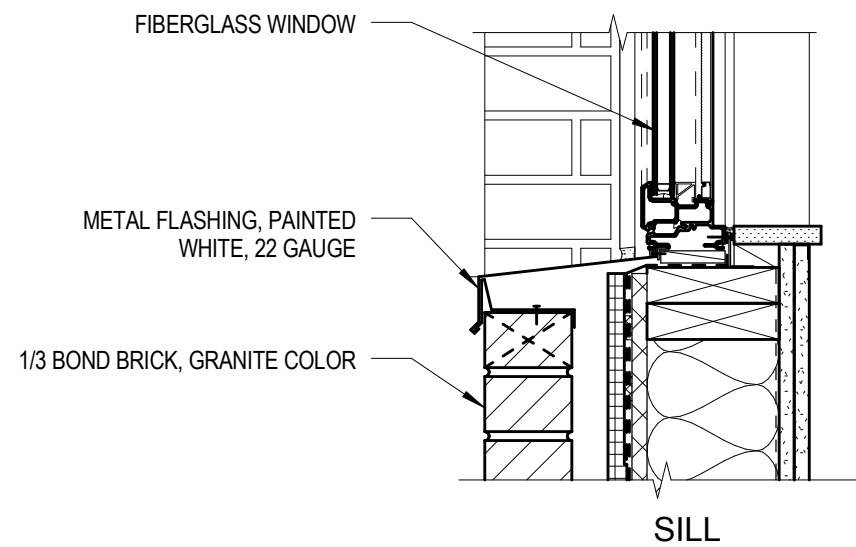
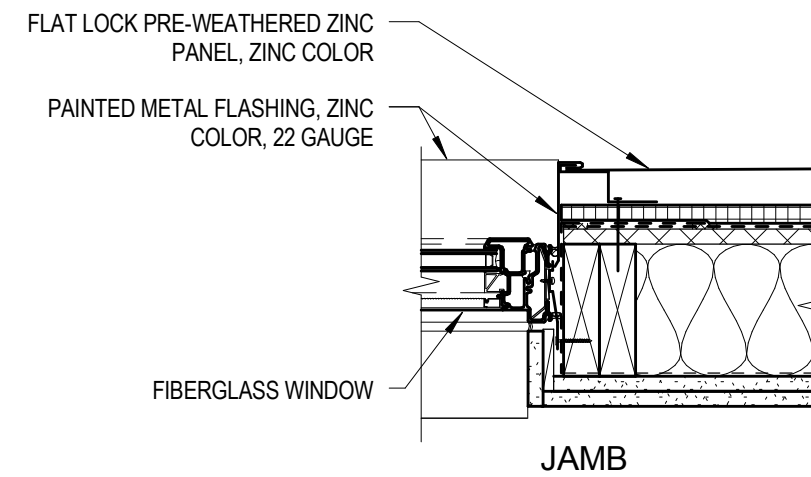
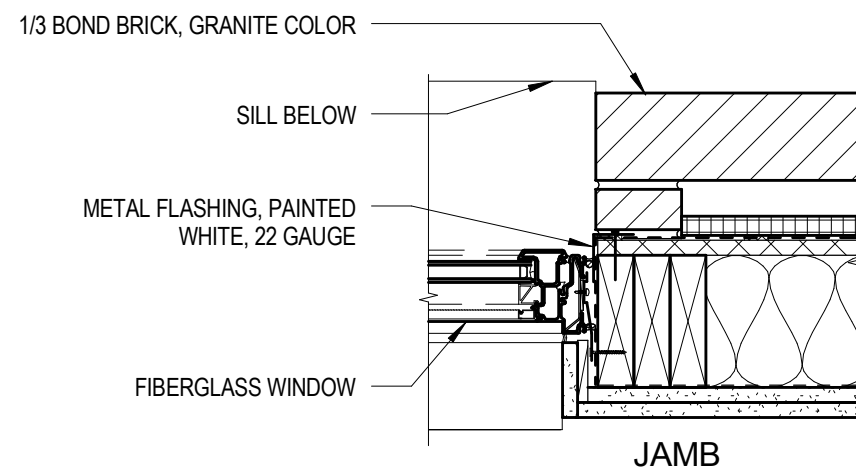
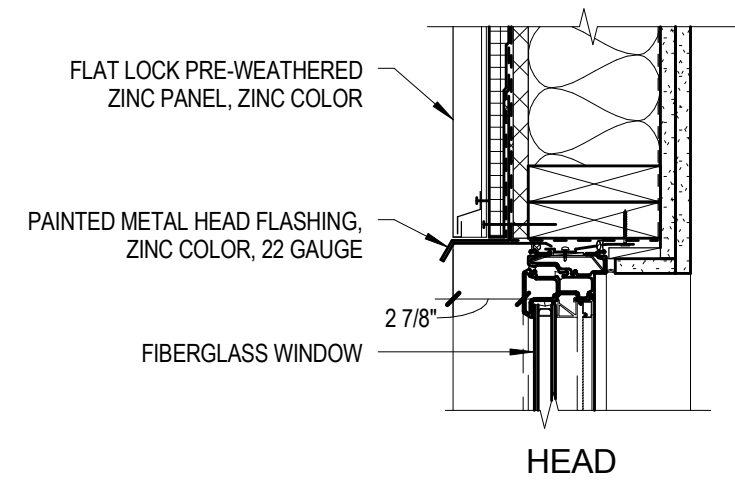
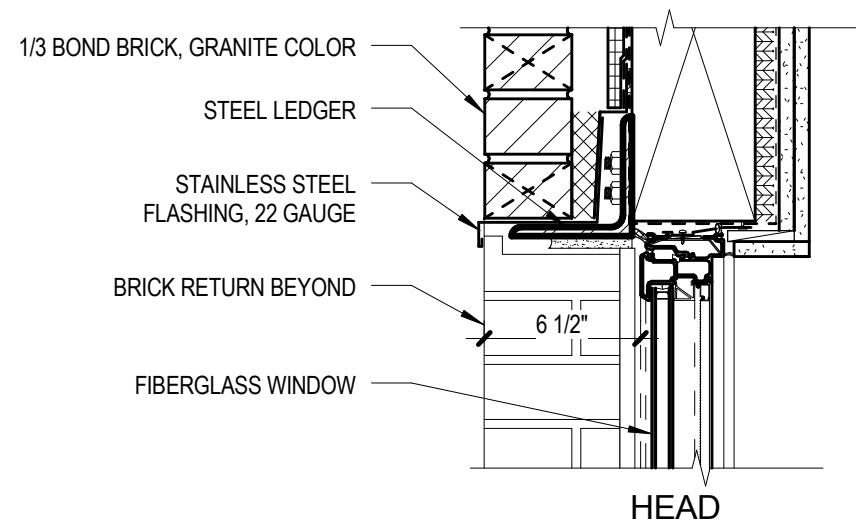

WINDOW @ BRICK 2
 1 1/2" = 1'-0"

WINDOW @ METAL PANEL 1
 1 1/2" = 1'-0"

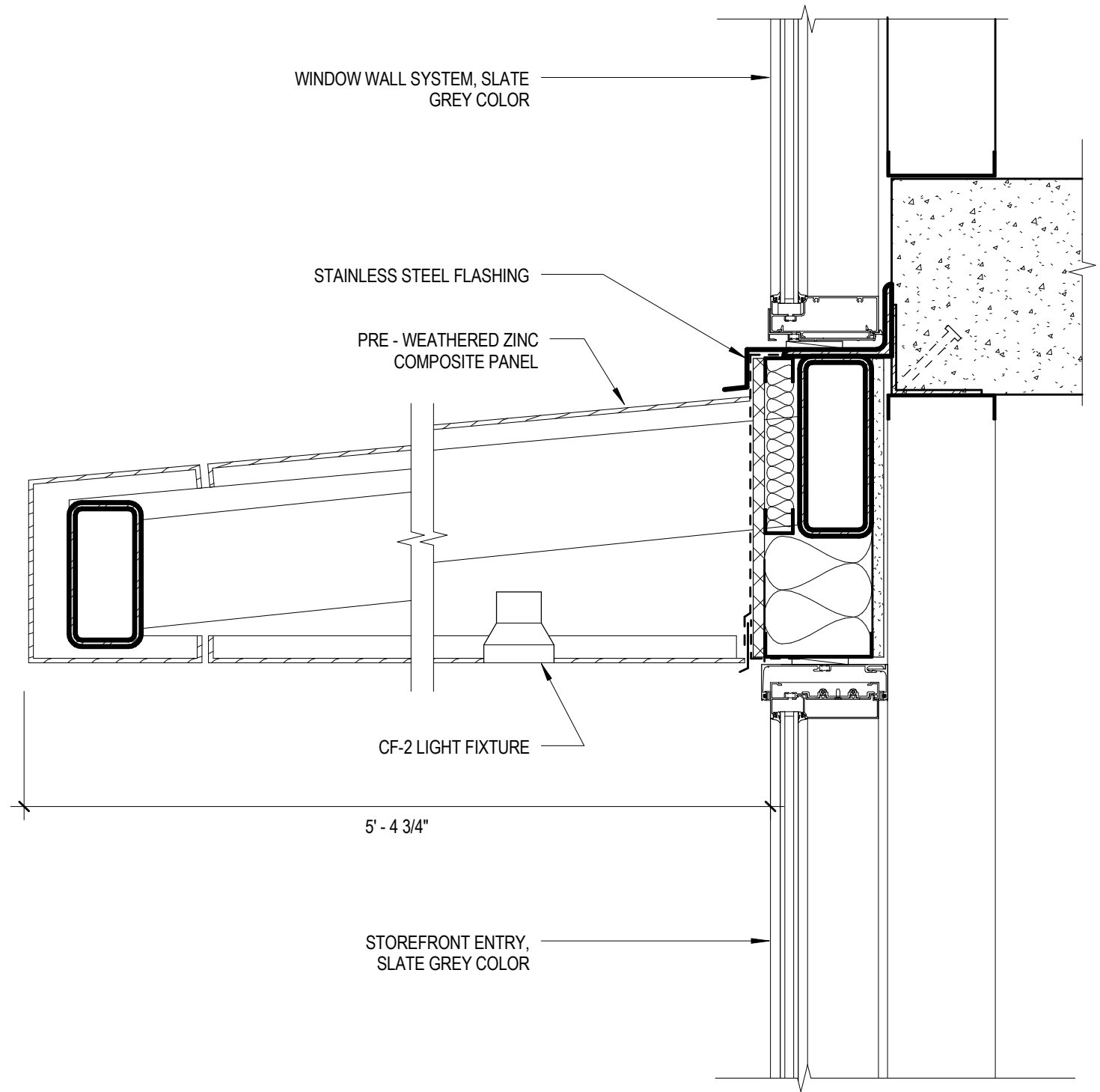

ENTRY CANOPY (2)
 1 1/2" = 1'-0"

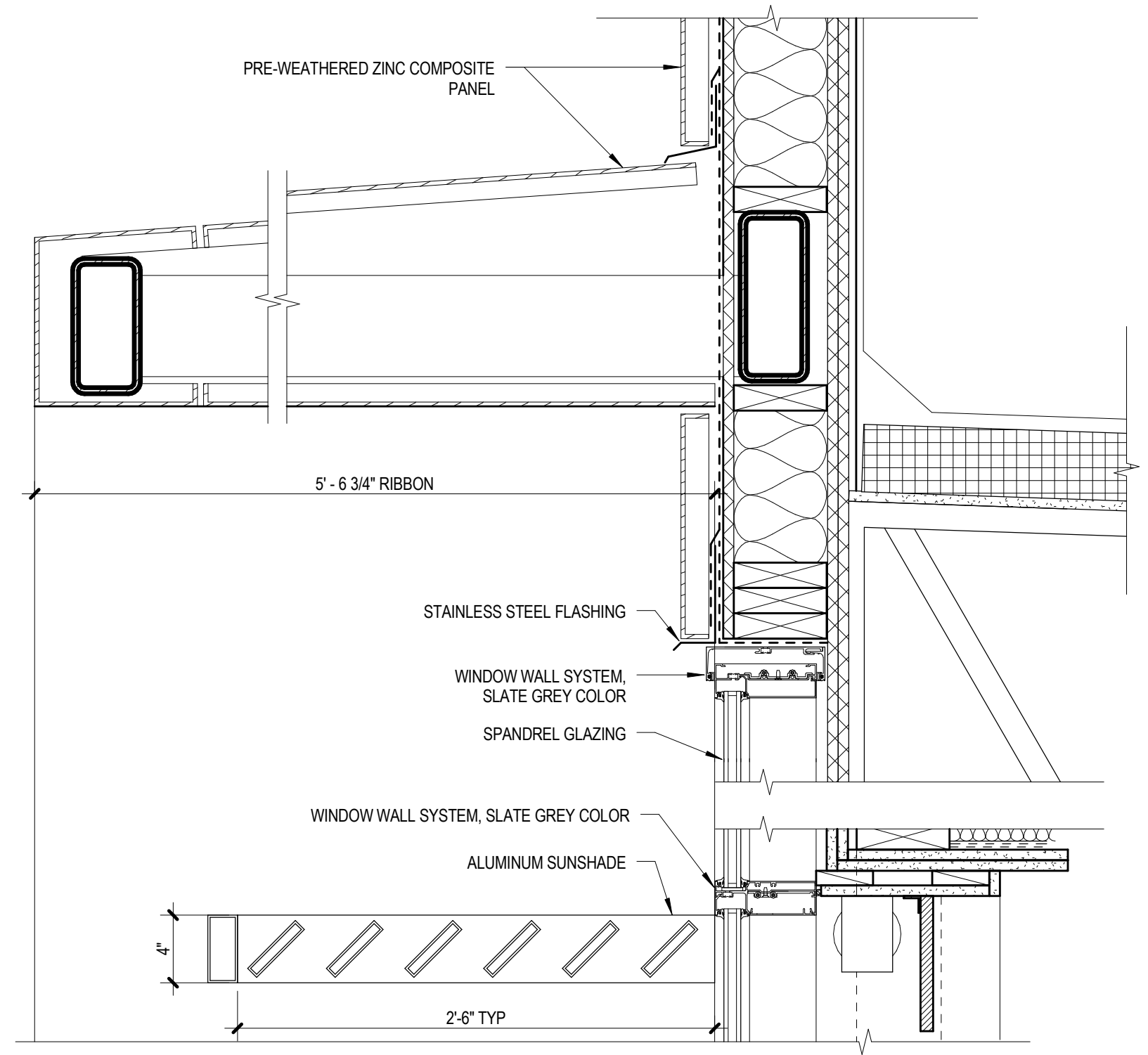

CANOPY @ WINDOW WALL (1)
 1 1/2" = 1'-0"

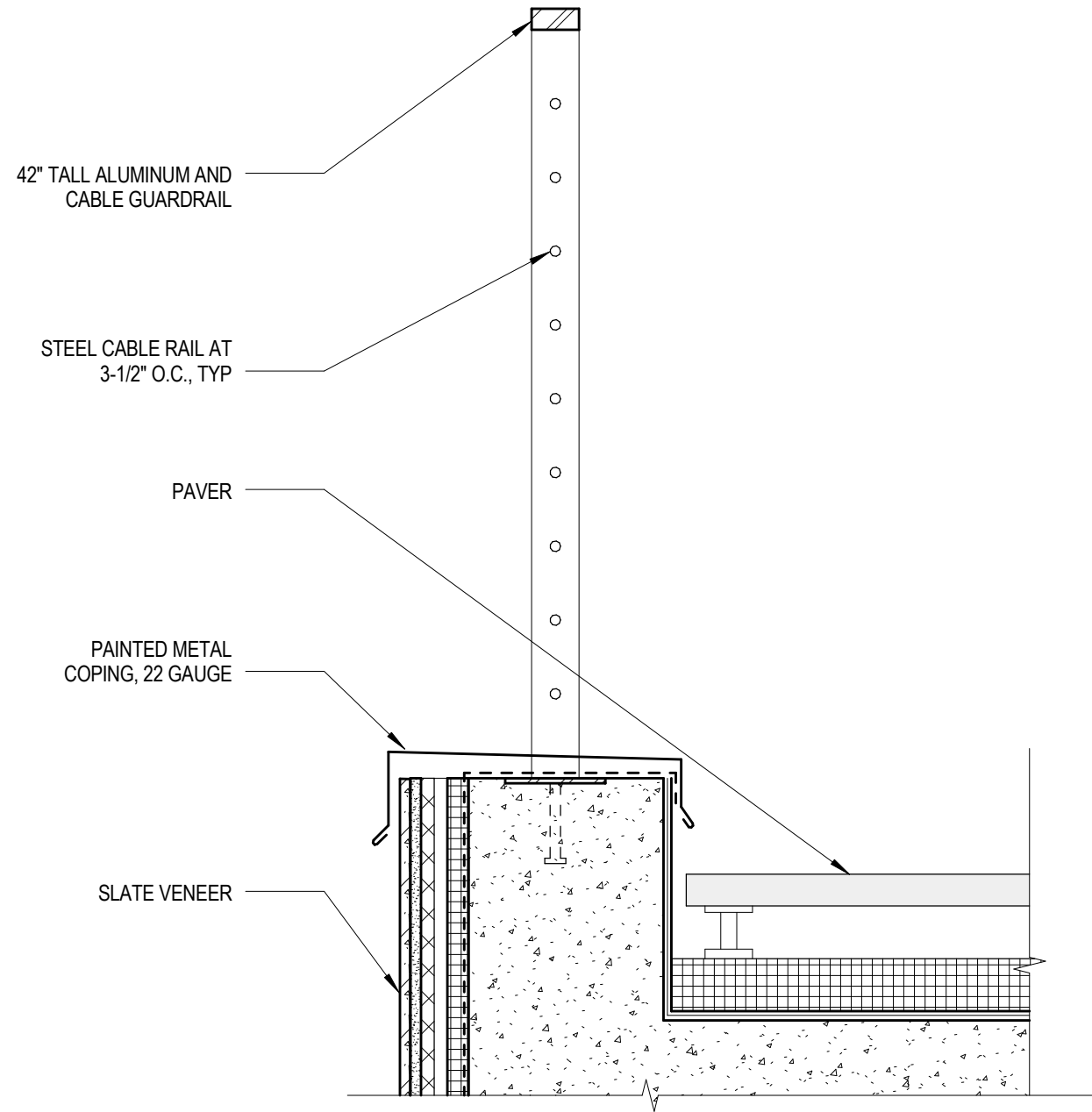

GUARDRAIL AT TERRACE ROOF (2)
 1 1/2" = 1'-0"

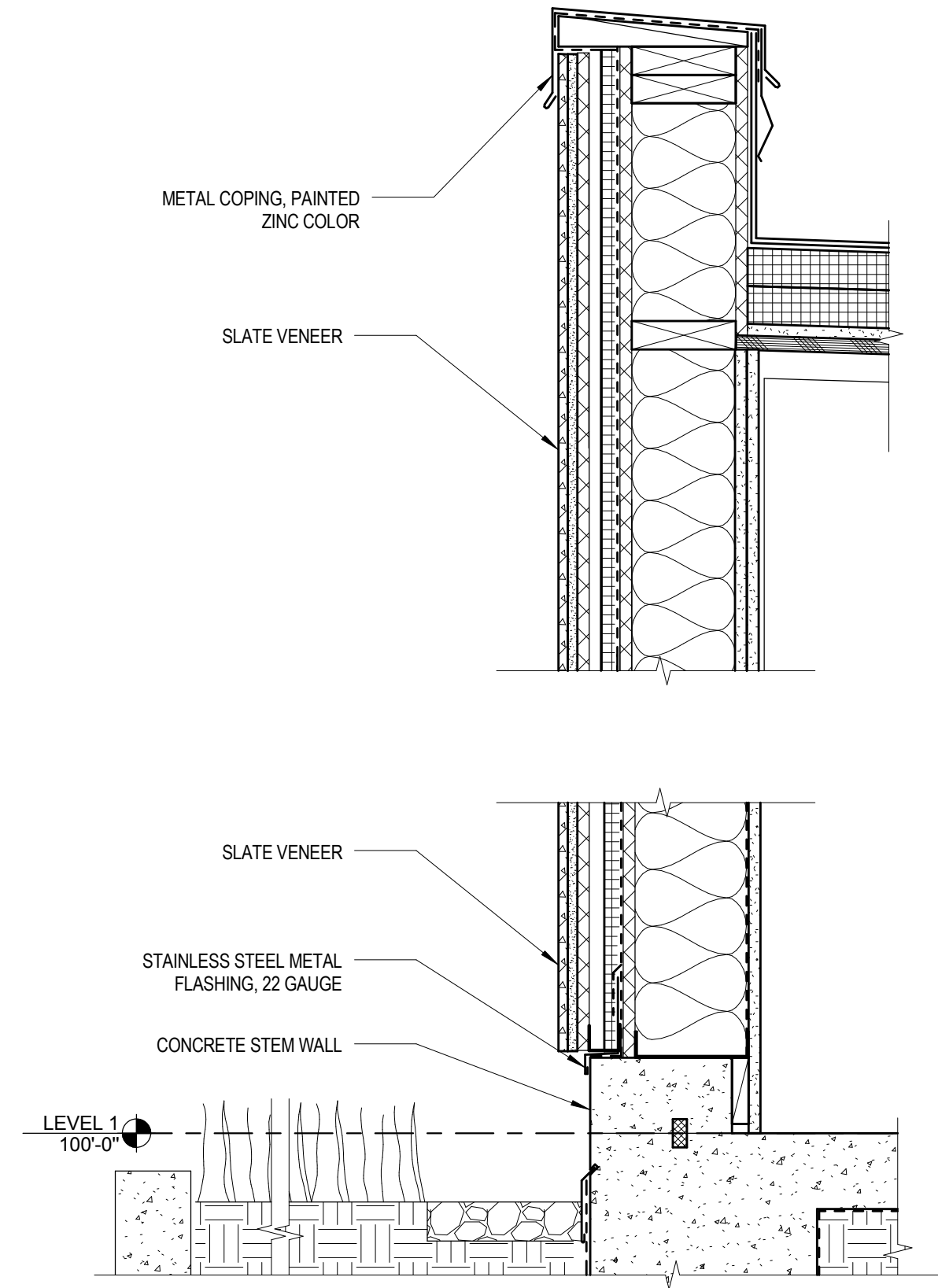

SECTION AT SLATE (1)
 1 1/2" = 1'-0"

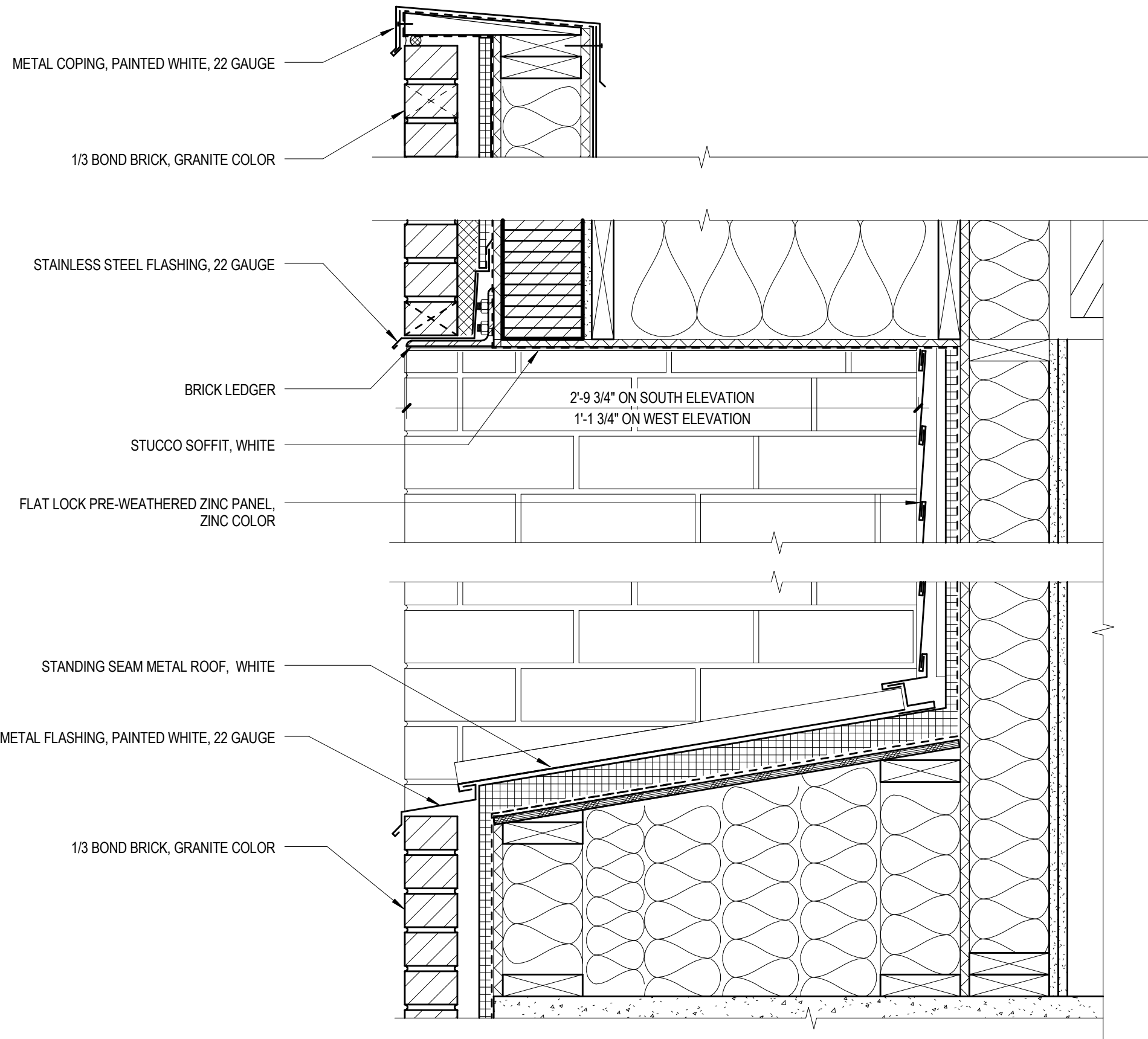

FLAT LOCK PANEL RECESS

1 1/2" = 1'-0"

1

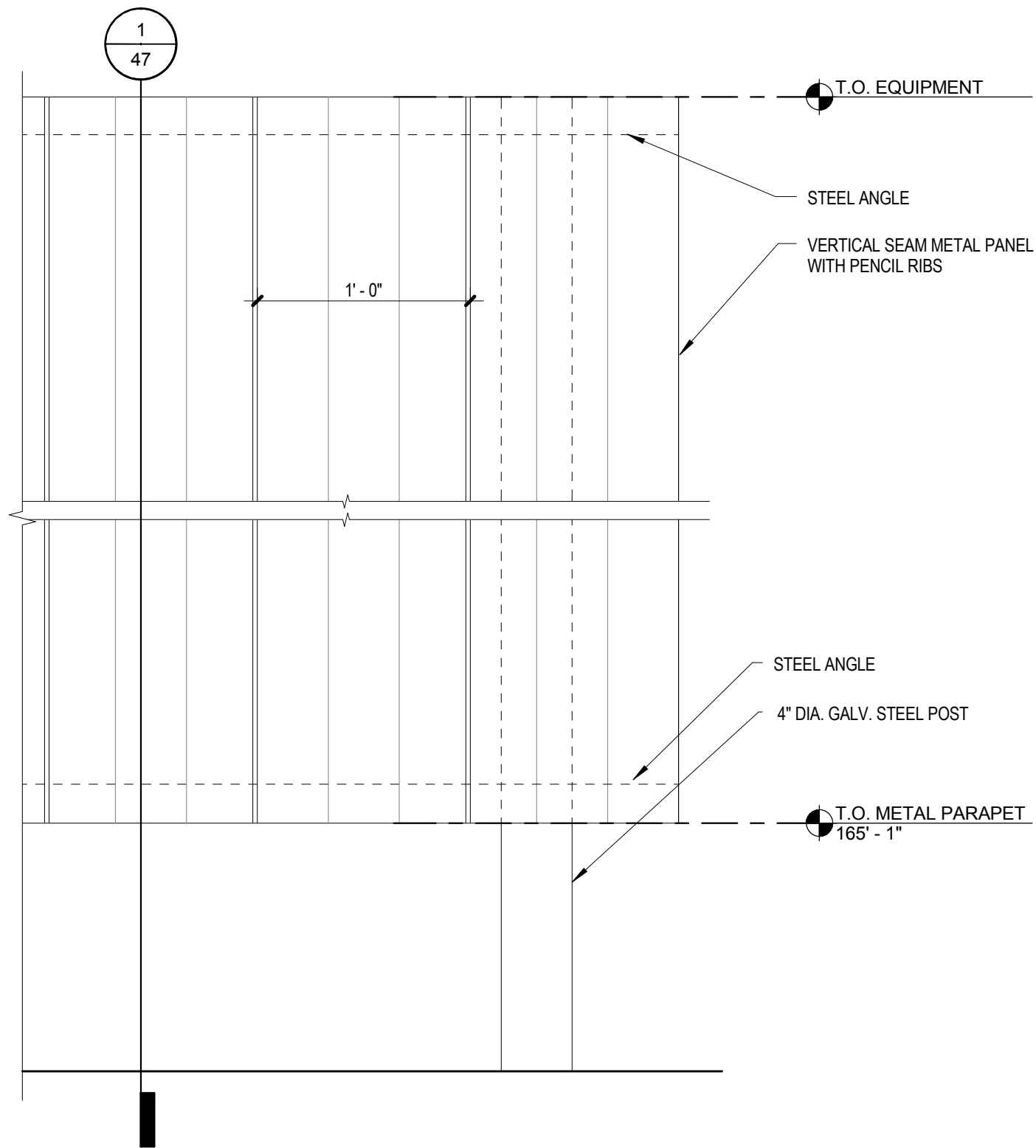

ROOF SCREEN ELEVATION

1 1/2" = 1'-0"

2

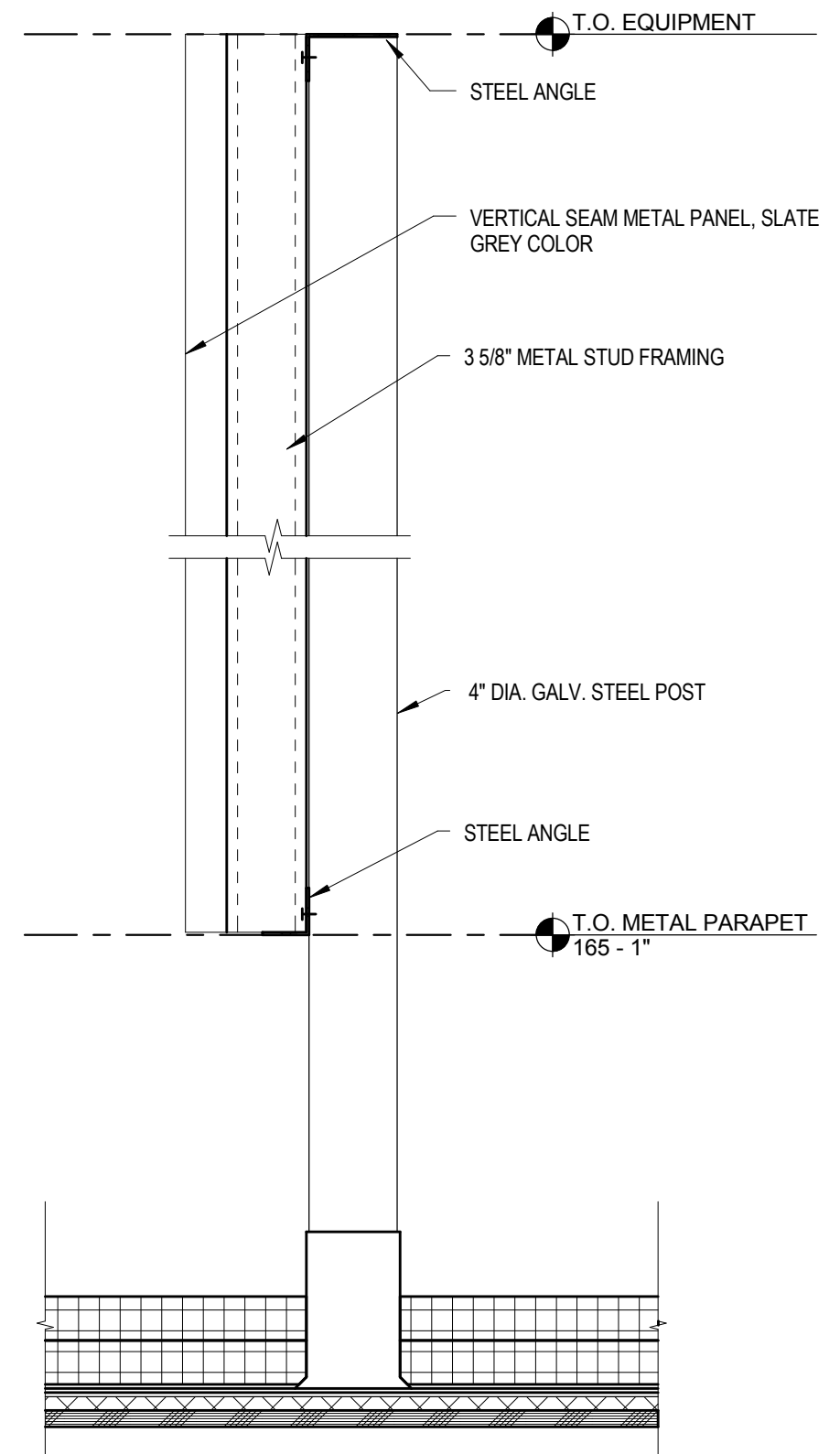

SECTION @ ROOF SCREEN

1 1/2" = 1'-0"

1

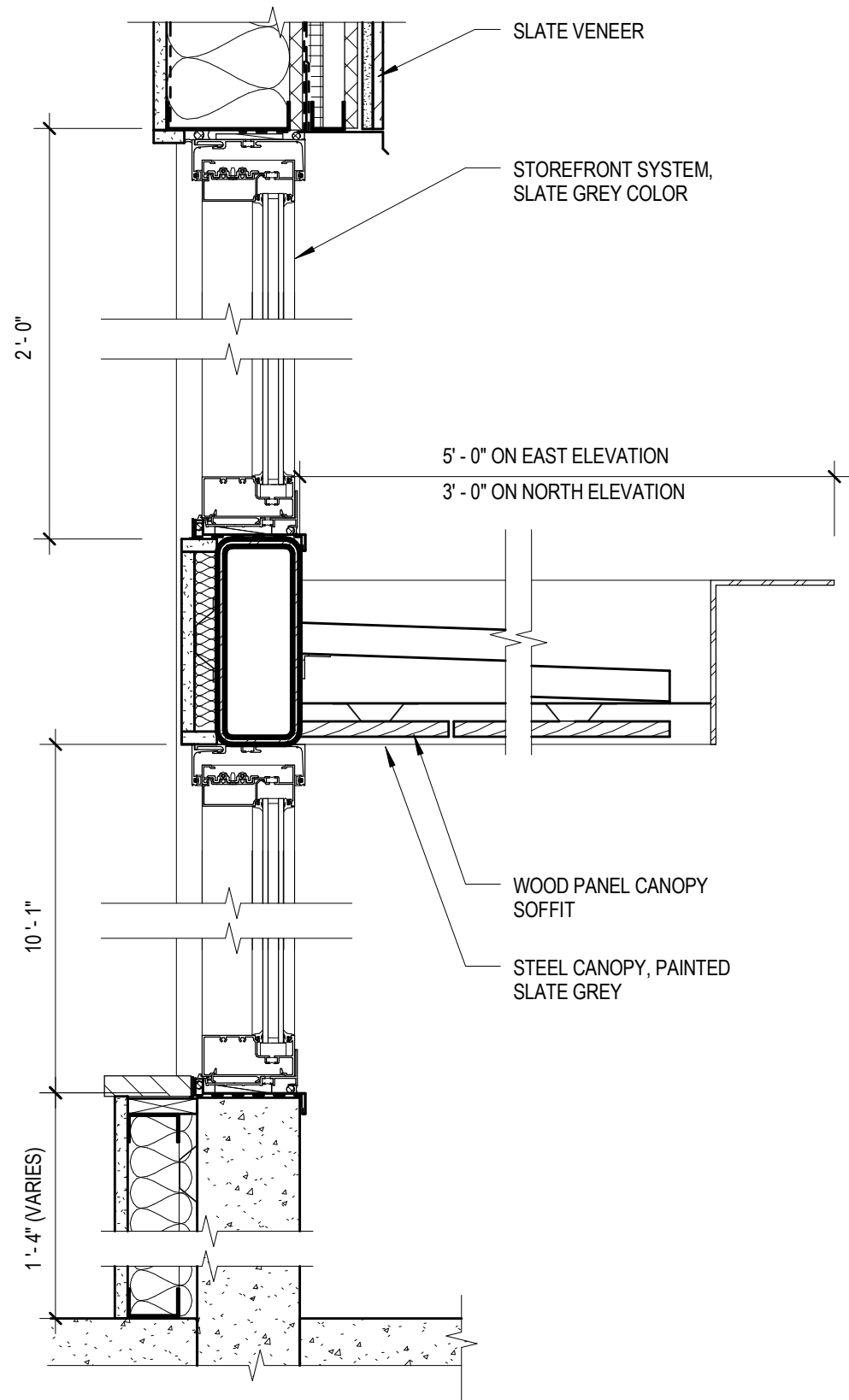

CANOPY @ RETAIL

1 1/2" = 1'-0"

2

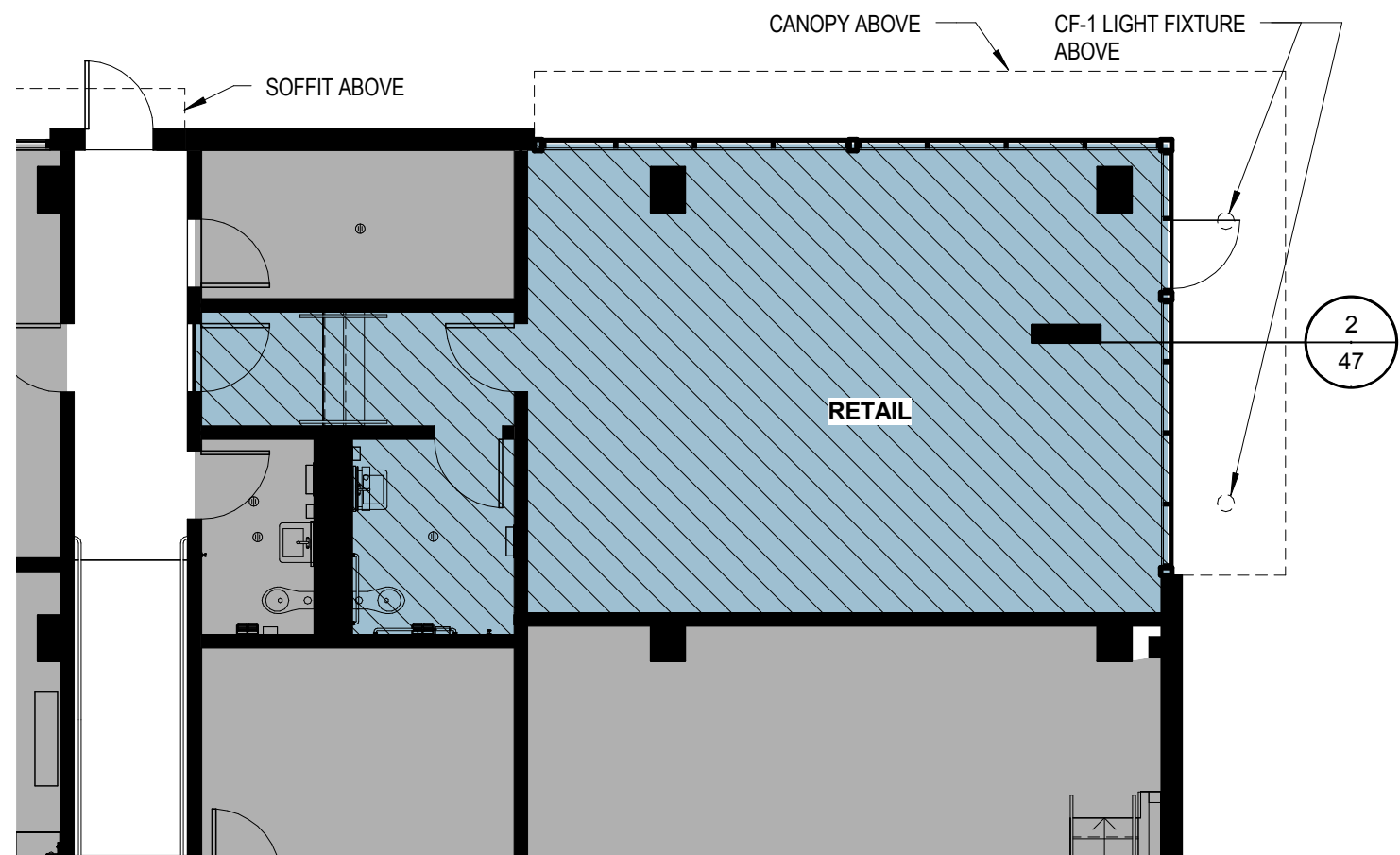

RETAIL AREA 763 SF*
*147 SF SUPPORT AREA

LEVEL 1 RETAIL

1/8" = 1'-0"

1







WEST ELEVATION 1
1/8" = 1'-0"

KEYNOTES - EXTERIOR ELEVATIONS

- 1 NORMAN SIZE BRICK, 1/3 RUNNING BOND
- 2 FLAT LOCK METAL PANEL SYSTEM
- 3 SLATE VENEER
- 4 STOREFRONT GLAZING SYSTEM
- 5 WINDOW WALL GLAZING SYSTEM
- 6 STEEL CANOPY WITH WOOD UNDERSIDE
- 7 STUCCO REVEAL
- 8 CONCRETE CURB
- 9 SUNSHADE
- 10 VERTICAL SEAM METAL PANEL MECHANICAL SCREENING
- 11 ALL GLASS ENTRY DOOR, AUTOMATIC SWING
- 12 LANDSCAPE PLANTER AND WATER FEATURE
- 13 PARKING GARAGE GLAZED RIGID ROLLING DOOR
- 14 SCUPPER AND DOWNSPOUT
- 15 LOUVER
- 16 HOSE BIB
- 17 PLANTER WALL
- 18 STEEL CABLE/ALUMINUM GUARDRAIL
- 19 CONTROL JOINT
- 20 GENERATOR REMOTE FUEL FILL PORT
- 21 GAS METER
- 22 PRE-WEATHERED ZINC COMPOSITE PANEL
- 23 STEEL AND GLASS CANOPY

LEGEND - EXTERIOR ELEVATIONS

-  FLAT LOCK METAL PANEL
-  BRICK
-  SLATE VENEER
-  CONCRETE







NORTH ELEVATION 2
1/8" = 1'-0"

KEYNOTES - EXTERIOR ELEVATIONS

- 1 NORMAN SIZE BRICK, 1/3 RUNNING BOND
- 2 FLAT LOCK METAL PANEL SYSTEM
- 3 SLATE VENEER
- 4 STOREFRONT GLAZING SYSTEM
- 5 WINDOW WALL GLAZING SYSTEM
- 6 STEEL CANOPY WITH WOOD UNDERSIDE
- 7 STUCCO REVEAL
- 8 CONCRETE CURB
- 9 SUNSHADE
- 10 VERTICAL SEAM METAL PANEL MECHANICAL SCREENING
- 11 ALL GLASS ENTRY DOOR, AUTOMATIC SWING
- 12 LANDSCAPE PLANTER AND WATER FEATURE
- 13 PARKING GARAGE GLAZED RIGID ROLLING DOOR
- 14 SCUPPER AND DOWNSPOUT
- 15 LOUVER
- 16 HOSE BIB
- 17 PLANTER WALL
- 18 STEEL CABLE/ALUMINUM GUARDRAIL
- 19 CONTROL JOINT
- 20 GENERATOR REMOTE FUEL FILL PORT
- 21 GAS METER

LEGEND - EXTERIOR ELEVATIONS

-  FLAT LOCK METAL PANEL
-  BRICK
-  SLATE VENEER
-  CONCRETE

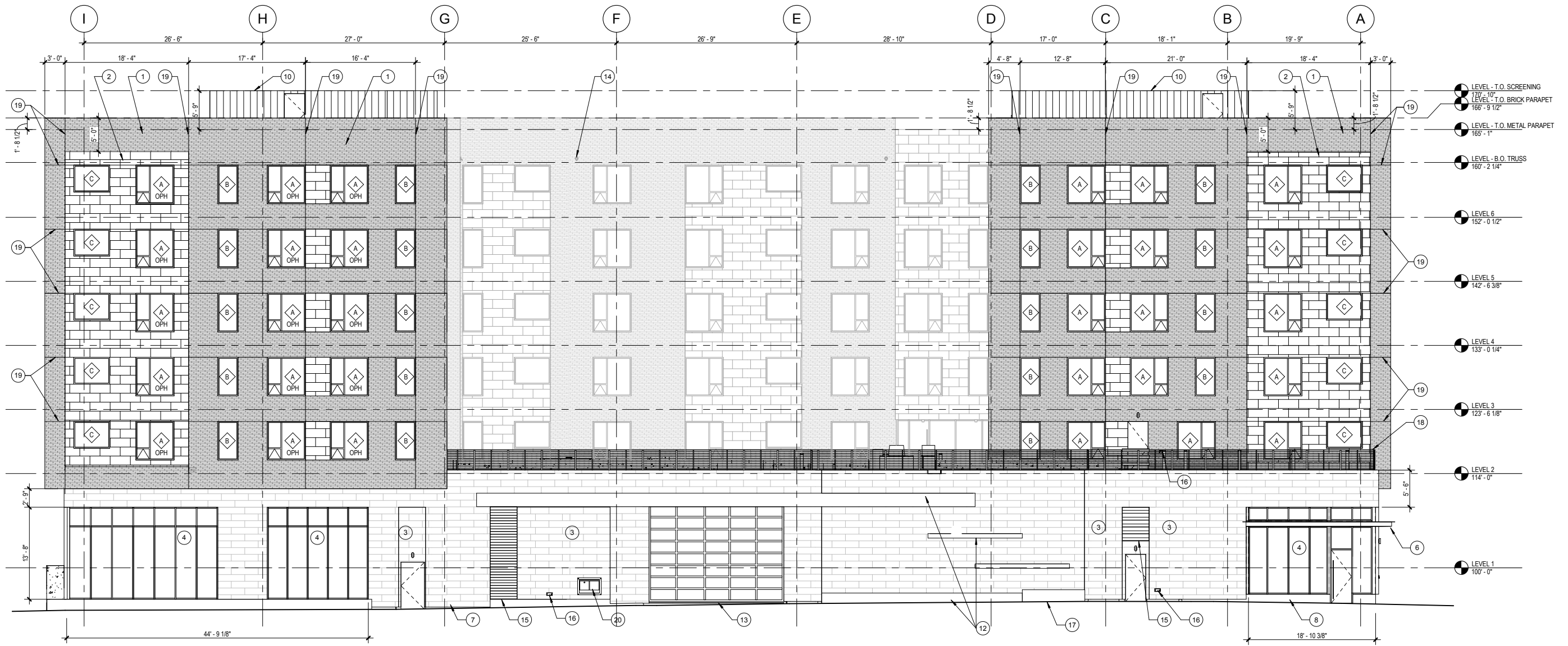





EAST ELEVATION 1
1/8" = 1'-0"

KEYNOTES - EXTERIOR ELEVATIONS

- 1 NORMAN SIZE BRICK, 1/3 RUNNING BOND
- 2 FLAT LOCK METAL PANEL SYSTEM
- 3 SLATE VENEER
- 4 STOREFRONT GLAZING SYSTEM
- 5 WINDOW WALL GLAZING SYSTEM
- 6 STEEL CANOPY WITH WOOD UNDERSIDE
- 7 STUCCO REVEAL
- 8 CONCRETE CURB
- 9 SUNSHADE
- 10 VERTICAL SEAM METAL PANEL MECHANICAL SCREENING
- 11 ALL GLASS ENTRY DOOR, AUTOMATIC SWING
- 12 LANDSCAPE PLANTER AND WATER FEATURE
- 13 PARKING GARAGE GLAZED RIGID ROLLING DOOR
- 14 SCUPPER AND DOWNSPOUT
- 15 LOUVER
- 16 HOSE BIB
- 17 PLANTER WALL
- 18 STEEL CABLE/ALUMINUM GUARDRAIL
- 19 CONTROL JOINT
- 20 GENERATOR REMOTE FUEL FILL PORT
- 21 GAS METER
- 22 PRE-WEATHERED ZINC COMPOSITE PANEL
- 23 STEEL AND GLASS CANOPY

LEGEND - EXTERIOR ELEVATIONS

-  FLAT LOCK METAL PANEL
-  BRICK
-  SLATE VENEER
-  CONCRETE









SOUTH ELEVATION 2
1/8" = 1'-0"

KEYNOTES - EXTERIOR ELEVATIONS

- 1 NORMAN SIZE BRICK, 1/3 RUNNING BOND
- 2 FLAT LOCK METAL PANEL SYSTEM
- 3 SLATE VENEER
- 4 STOREFRONT GLAZING SYSTEM
- 5 WINDOW WALL GLAZING SYSTEM
- 6 STEEL CANOPY WITH WOOD UNDERSIDE
- 7 STUCCO REVEAL
- 8 CONCRETE CURB
- 9 SUNSHADE
- 10 VERTICAL SEAM METAL PANEL MECHANICAL SCREENING
- 11 ALL GLASS ENTRY DOOR, AUTOMATIC SWING
- 12 LANDSCAPE PLANTER AND WATER FEATURE
- 13 PARKING GARAGE GLAZED RIGID ROLLING DOOR
- 14 SCUPPER AND DOWNSPOUT
- 15 LOUVER
- 16 HOSE BIB
- 17 PLANTER WALL
- 18 STEEL CABLE/ALUMINUM GUARDRAIL
- 19 CONTROL JOINT
- 20 GENERATOR REMOTE FUEL FILL PORT
- 21 GAS METER
- 22 PRE-WEATHERED ZINC COMPOSITE PANEL
- 23 STEEL AND GLASS CANOPY

LEGEND - EXTERIOR ELEVATIONS

-  FLAT LOCK METAL PANEL
-  BRICK
-  SLATE VENEER
-  CONCRETE







NORTH COURTYARD ELEVATION 1
1/8" = 1'-0"

KEYNOTES - EXTERIOR ELEVATIONS

- 1 NORMAN SIZE BRICK, 1/3 RUNNING BOND
- 2 FLAT LOCK METAL PANEL SYSTEM
- 3 SLATE VENEER
- 4 STOREFRONT GLAZING SYSTEM
- 5 WINDOW WALL GLAZING SYSTEM
- 6 STEEL CANOPY WITH WOOD UNDERSIDE
- 7 STUCCO REVEAL
- 8 CONCRETE CURB
- 9 SUNSHADE
- 10 VERTICAL SEAM METAL PANEL MECHANICAL SCREENING
- 11 ALL GLASS ENTRY DOOR, AUTOMATIC SWING
- 12 LANDSCAPE PLANTER AND WATER FEATURE
- 13 PARKING GARAGE GLAZED RIGID ROLLING DOOR
- 14 SCUPPER AND DOWNSPOUT
- 15 LOUVER
- 16 HOSE BIB
- 17 PLANTER WALL
- 18 STEEL CABLE/ALUMINUM GUARDRAIL
- 19 CONTROL JOINT
- 20 GENERATOR REMOTE FUEL FILL PORT
- 21 GAS METER
- 22 PRE-WEATHERED ZINC COMPOSITE PANEL
- 23 STEEL AND GLASS CANOPY

LEGEND - EXTERIOR ELEVATIONS

-  FLAT LOCK METAL PANEL
-  BRICK
-  SLATE VENEER
-  CONCRETE

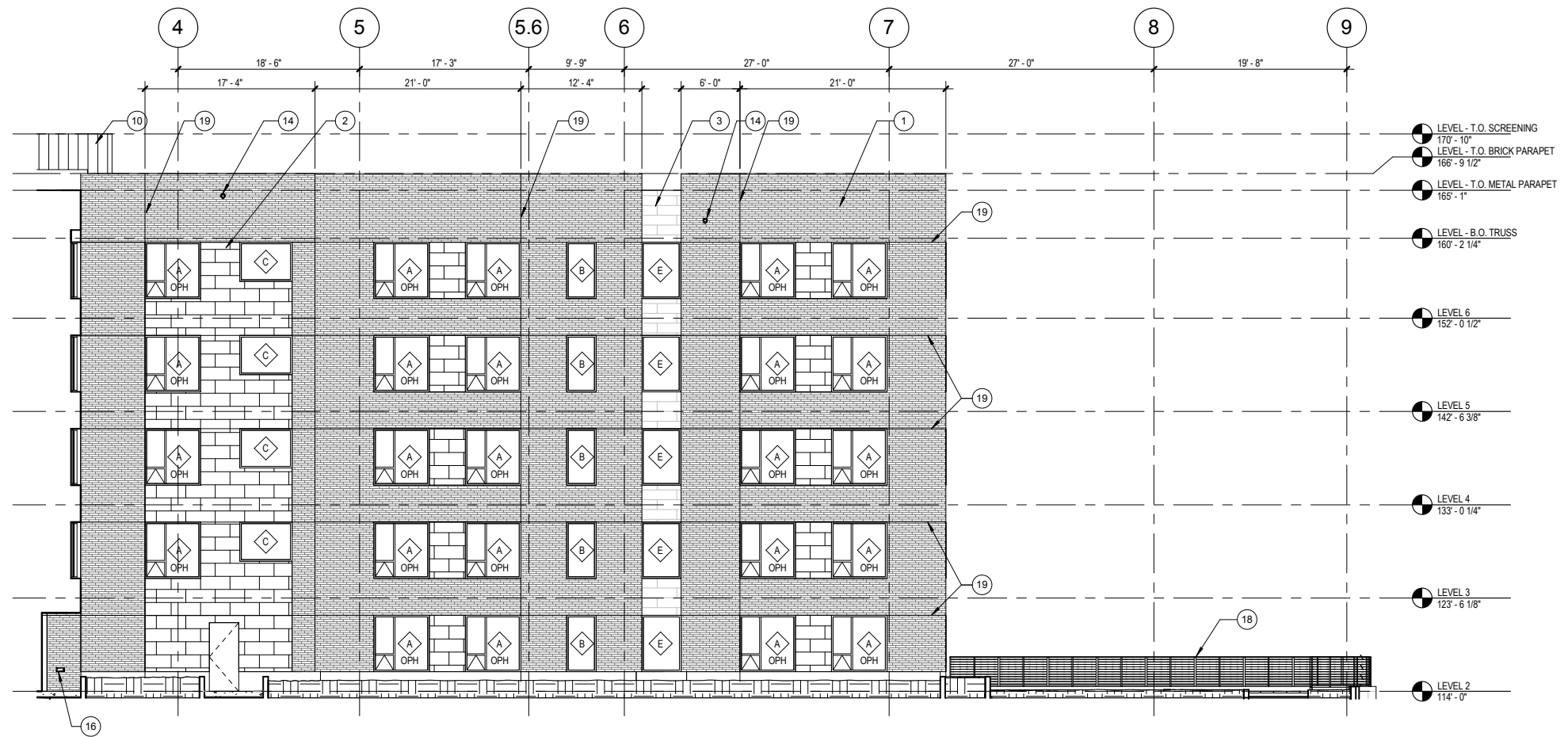





SOUTH COURTYARD ELEVATION 3
1/8" = 1'-0"

KEYNOTES - EXTERIOR ELEVATIONS

- 1 NORMAN SIZE BRICK, 1/3 RUNNING BOND
- 2 FLAT LOCK METAL PANEL SYSTEM
- 3 SLATE VENEER
- 4 STOREFRONT GLAZING SYSTEM
- 5 WINDOW WALL GLAZING SYSTEM
- 6 STEEL CANOPY WITH WOOD UNDERSIDE
- 7 STUCCO REVEAL
- 8 CONCRETE CURB
- 9 SUNSHADE
- 10 VERTICAL SEAM METAL PANEL MECHANICAL SCREENING
- 11 ALL GLASS ENTRY DOOR, AUTOMATIC SWING
- 12 LANDSCAPE PLANTER AND WATER FEATURE
- 13 PARKING GARAGE GLAZED RIGID ROLLING DOOR
- 14 SCUPPER AND DOWNSPOUT
- 15 LOUVER
- 16 HOSE BIB
- 17 PLANTER WALL
- 18 STEEL CABLE/ALUMINUM GUARDRAIL
- 19 CONTROL JOINT
- 20 GENERATOR REMOTE FUEL FILL PORT
- 21 GAS METER
- 22 PRE-WEATHERED ZINC COMPOSITE PANEL
- 23 STEEL AND GLASS CANOPY

LEGEND - EXTERIOR ELEVATIONS





-  FLAT LOCK METAL PANEL
-  BRICK
-  SLATE VENEER
-  CONCRETE



KEYNOTES - EXTERIOR ELEVATIONS

- 1 NORMAN SIZE BRICK, 1/3 RUNNING BOND
- 2 FLAT LOCK METAL PANEL SYSTEM
- 3 SLATE VENEER
- 4 STOREFRONT GLAZING SYSTEM
- 5 WINDOW WALL GLAZING SYSTEM
- 6 STEEL CANOPY WITH WOOD UNDERSIDE
- 7 STUCCO REVEAL
- 8 CONCRETE CURB
- 9 SUNSHADE
- 10 VERTICAL SEAM METAL PANEL MECHANICAL SCREENING
- 11 ALL GLASS ENTRY DOOR, AUTOMATIC SWING
- 12 LANDSCAPE PLANTER AND WATER FEATURE
- 13 PARKING GARAGE GLAZED RIGID ROLLING DOOR
- 14 SCUPPER AND DOWNSPOUT
- 15 LOUVER
- 16 HOSE BIB
- 17 PLANTER WALL
- 18 STEEL CABLE/ALUMINUM GUARDRAIL
- 19 CONTROL JOINT
- 20 GENERATOR REMOTE FUEL FILL PORT
- 21 GAS METER
- 22 PRE-WEATHERED ZINC COMPOSITE PANEL
- 23 STEEL AND GLASS CANOPY

LEGEND - EXTERIOR ELEVATIONS

-  FLAT LOCK METAL PANEL
-  BRICK
-  SLATE VENEER
-  CONCRETE