



contents

Cover.....	1
Contents.....	2
View from South.....	3
Neighborhood Context.....	4
Neighborhood Context.....	5
Neighborhood Context.....	6
Site Inspiration.....	7
Vicinity Map.....	8
Three Block Study.....	9
Site Plan.....	10
Storm Water/Utility Plan.....	11
Lighting Plan.....	12
FAR Diagrams.....	13
Level 1 Floor Plan.....	14
Level 2 Floor Plan.....	15
Level 3-6 Floor Plan.....	16
Roof Plan.....	17
Elevations.....	18
Elevations.....	19
Courtyard Elevations.....	20
Enlarged Elevation and Sections.....	21
Enlarged Elevation and Sections.....	22
Enlarged Elevation.....	23
Building Perspective From Northeast.....	24
Night Perspective From Northeast.....	25
Perspective Of Entrance.....	26
Streetscape Plan.....	27
Streetscape South Elevation.....	28
Streetscape South Section.....	29
Streetscape East Elevation.....	30
Streetscape East Section.....	31
Screen Wall Perspective.....	32
Screen Wall Perspective at Night.....	33
Screen Wall Details.....	34
Courtyard Landscape Plan.....	35
2nd Level Terrace South Section.....	36
2nd Level Terrace East Section.....	37
Terrace Details.....	38
Materials.....	39
Enlarged View of Slate Veneer.....	40
Parking Entry and Louver Sections.....	41
Storefront/Window Details.....	42
Window Details.....	43
Canopy Details.....	44
Wall Details.....	45
Wall Details.....	46
Roof Screen.....	47
Level 1 Retail.....	48
West Elevation.....	49
North Elevation.....	50
East Elevation.....	51
South Elevation.....	52
North Courtyard Elevation.....	53
South Courtyard Elevation.....	54
East Courtyard Elevation.....	55





view to south



view to east



view to north



view to west







SITE
48,645 SF



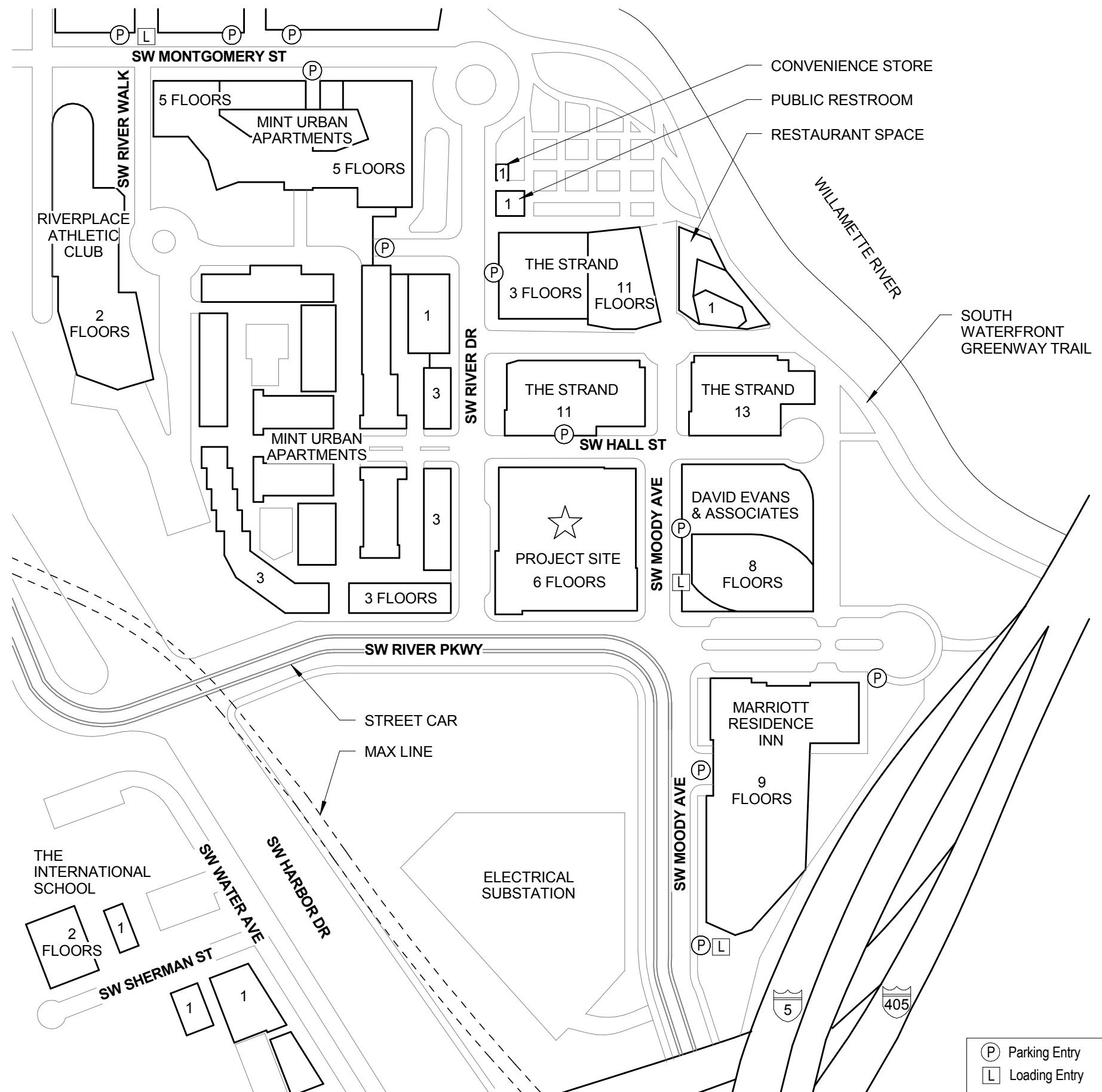



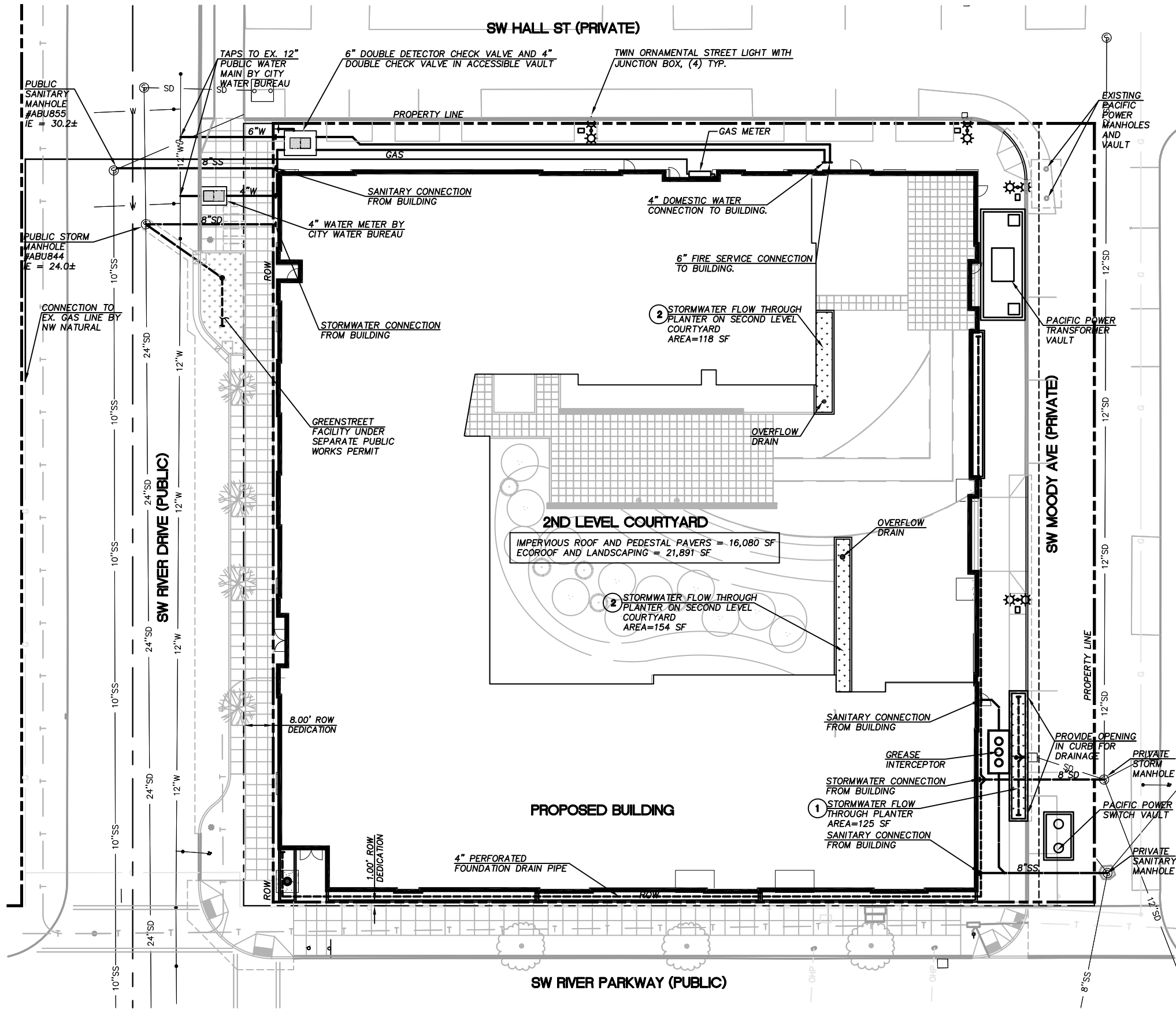

STORMWATER NARRATIVE

PRIVATE:
WATER QUALITY
 WATER QUALITY CONTROL IS MET WITH FLOW-THROUGH PLANTERS AND ECOROOF. THE PLANTERS AND ECOROOF ARE SIZED TO TREAT 93% OF THE ON-SITE IMPERVIOUS AREA. A SPECIAL CIRCUMSTANCE IS BEING REQUESTED FOR THE REMAINING IMPERVIOUS AREA.

WATER QUANTITY
 WATER QUANTITY CONTROL IS NOT REQUIRED PER BES PRE-APPLICATION CONFERENCE RESPONSE. (STORM-ONLY SEWER THAT DISCHARGES TO THE WILLAMETTE).

DISPOSAL
 A CONNECTION FROM THE SITE WILL BE MADE TO EXISTING PUBLIC STORM-ONLY SEWER. THE PROJECT WILL FALL UNDER CATEGORY 3 OF THE STORMWATER DISPOSAL HIERARCHY.

PUBLIC:
WATER QUALITY/QUANTITY
 STORMWATER MANAGEMENT IS REQUIRED FOR THE IMPROVEMENTS TO THE PUBLIC SIDEWALK IN THE PUBLIC RIGHT OF WAY ON SW RIVER DR. GREENSTREET FLOW-THROUGH PLANTERS WILL MANAGE NEW IMPERVIOUS AREA CONSTRUCTED ON SW RIVER DR. EXISTING STORMWATER DRAINAGE FOR THE RIGHT OF WAY WILL BE PROTECTED DURING CONSTRUCTION.

DISPOSAL
 DISPOSAL FOR THE GREENSTREET FLOW-THROUGH PLANTERS WILL BE TO THE PUBLIC STORM SEWER IN SW RIVER DR.

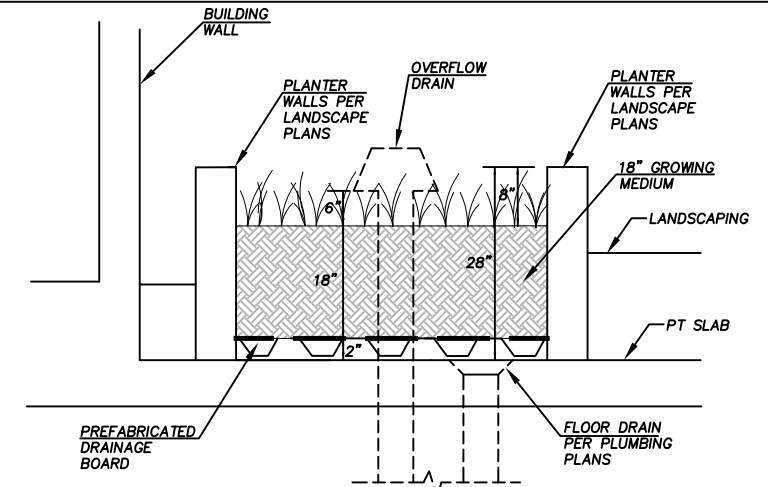

NOTES:
 1. PLANTING PER LANDSCAPE PLANS.
 2. GROWING MEDIUM PER SPECIFICATIONS.

2 STORMWATER FLOW THROUGH PLANTER
 NTS

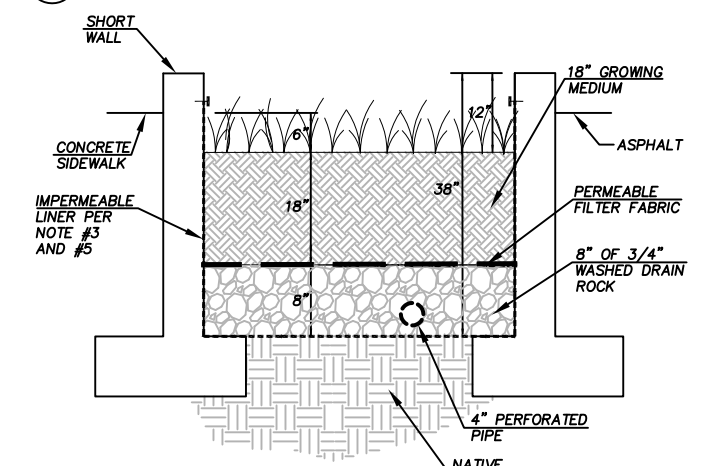

NOTES:
 1. PLANTING PER LANDSCAPE PLANS.
 2. GROWING MEDIUM PER SPECIFICATIONS.
 3. IMPERMEABLE LINER SHALL BE 30 MIL MINIMUM. ATTACH IMPERMEABLE LINER TO CONCRETE ABOVE OVERFLOW DRAIN.
 4. PROVIDE WATERTIGHT PENETRATION THROUGH IMPERMEABLE LINER FOR OUTFLOW FROM OVERFLOW DRAIN.
 5. CONCRETE PLANTER BOX SHALL BE POURED MONOLITHICALLY WITH NO COLD JOINTS TO AVOID THE REQUIREMENT FOR A LINER.

1 STORMWATER FLOW THROUGH PLANTER
 NTS

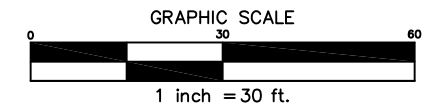

Fixture type CF-1
LED in Canopy



Fixture type CF-2
LED in Soffit



Fixture type CF-3
Wall Mounted Fixture



Fixture type CF-4
Wall Mounted Downlight



Fixture type CG-1
LED Site Lightform



Fixture type CG-2
Uplight



Fixture type CG-3
LED Uplight Fixture



Fixture type PN-1
Accent Fixture

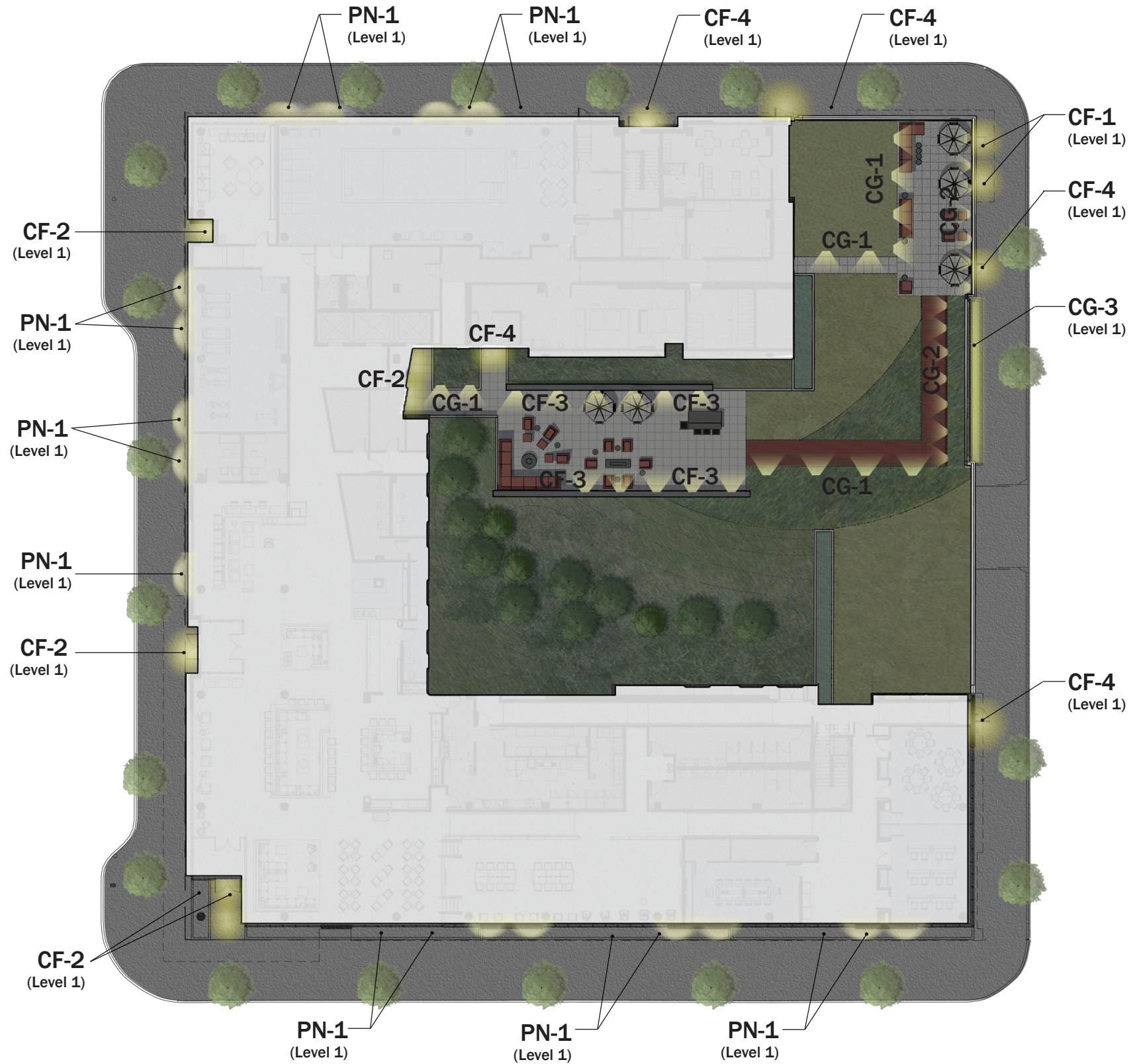

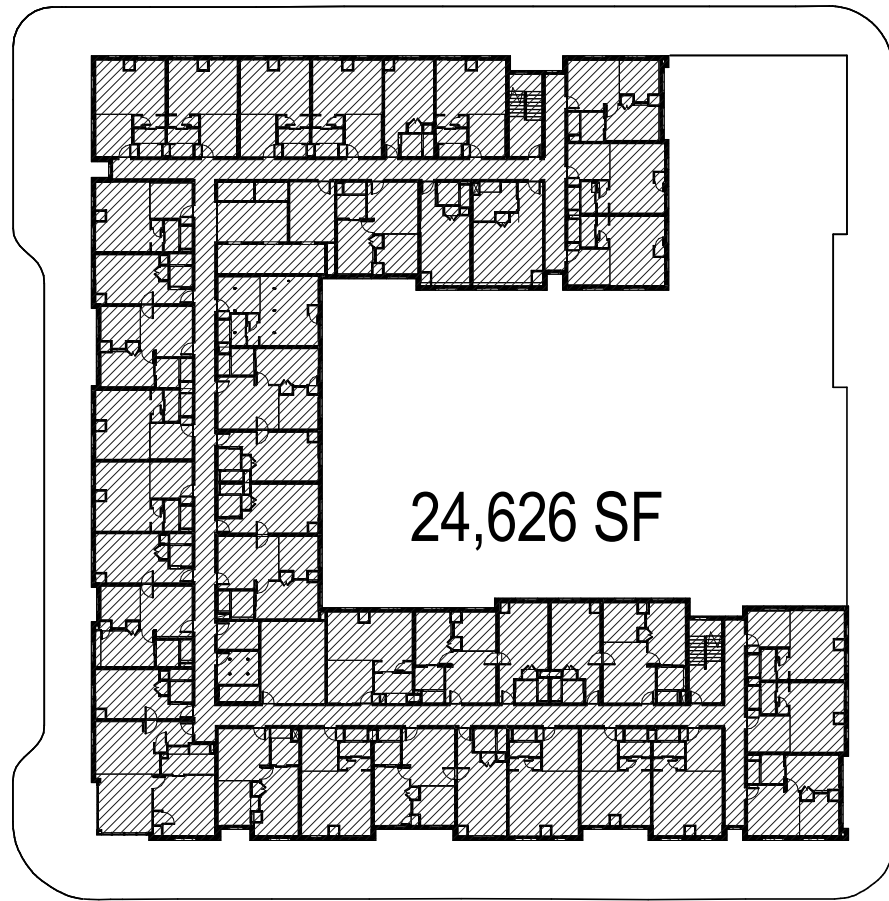

LEVEL 3 - LEVEL 6 3
1" = 50'-0"

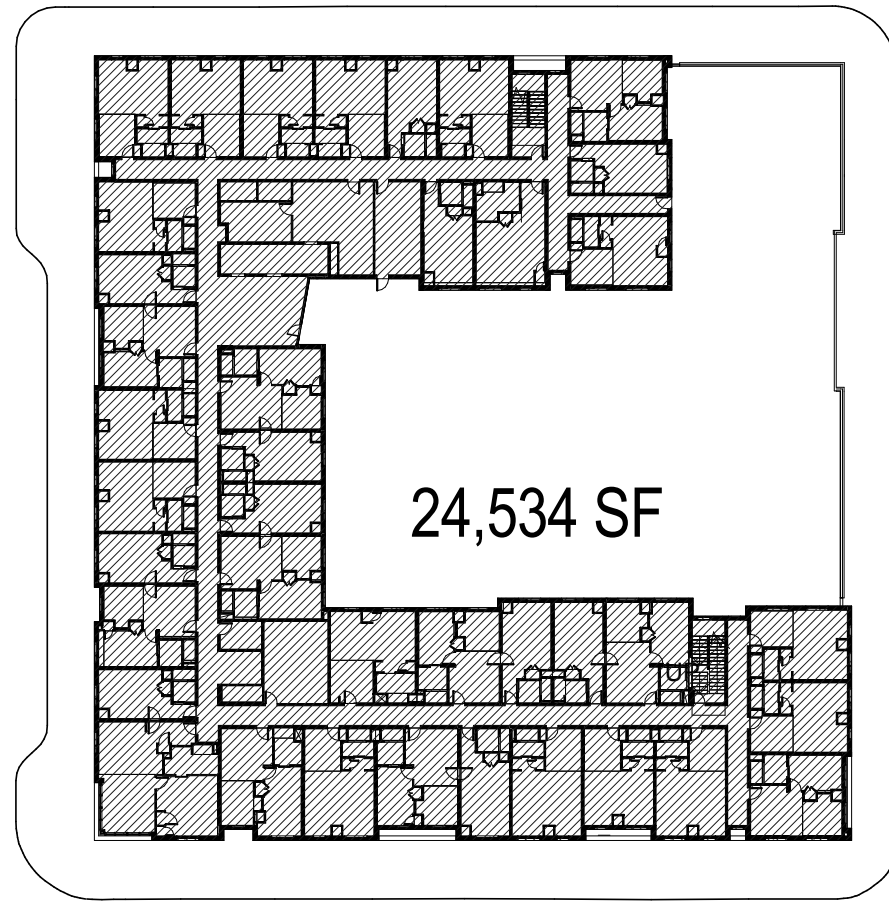

LEVEL 2 2
1" = 50'-0"

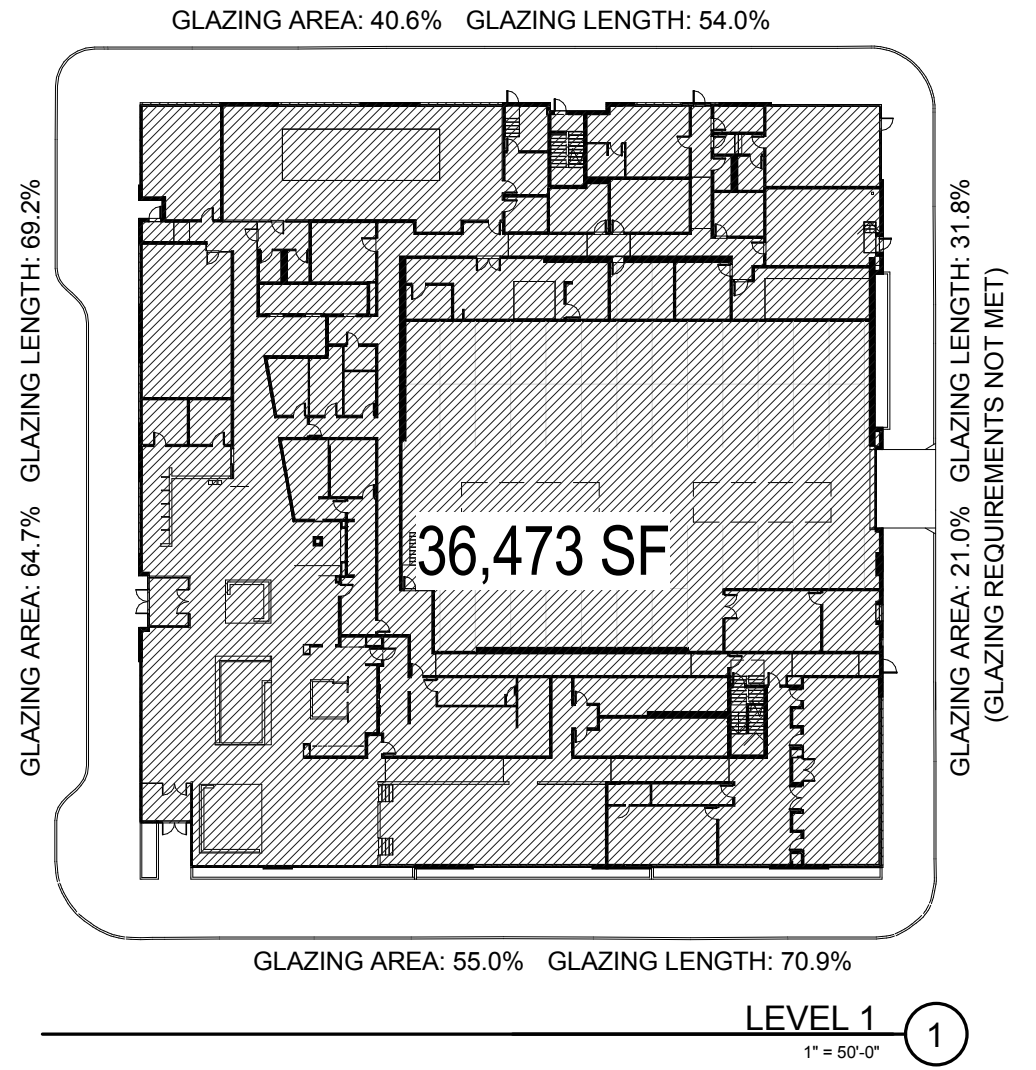

LEVEL 1 FLOOR PLAN



Note: Short term bike parking requirements to be accomplished by paying into bike parking fund per: 33.226.220

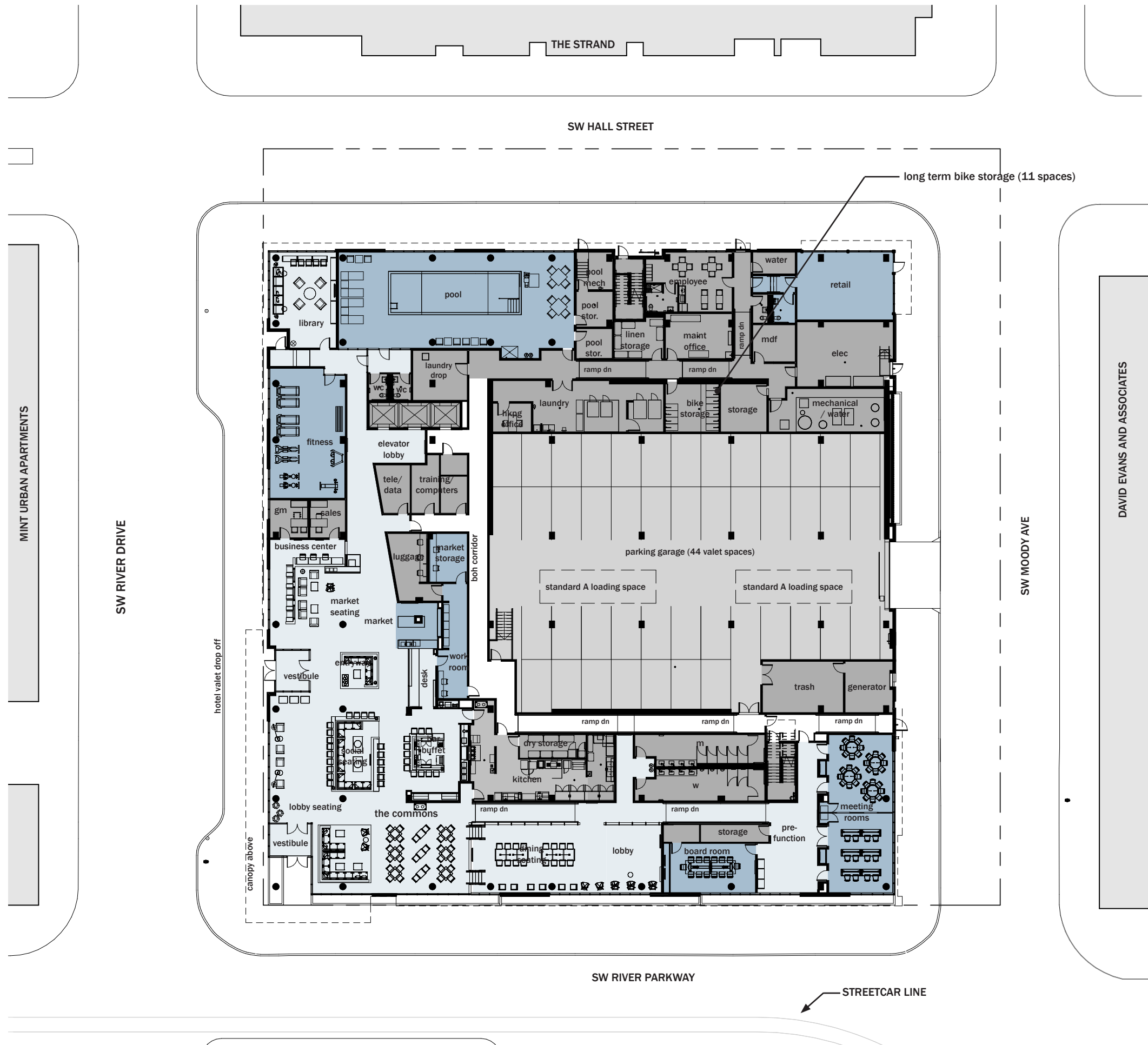

THE STRAND

SW HALL STREET

MINT URBAN APARTMENTS

SW RIVER DRIVE

SW MOODY AVE

DAVID EVANS AND ASSOCIATES

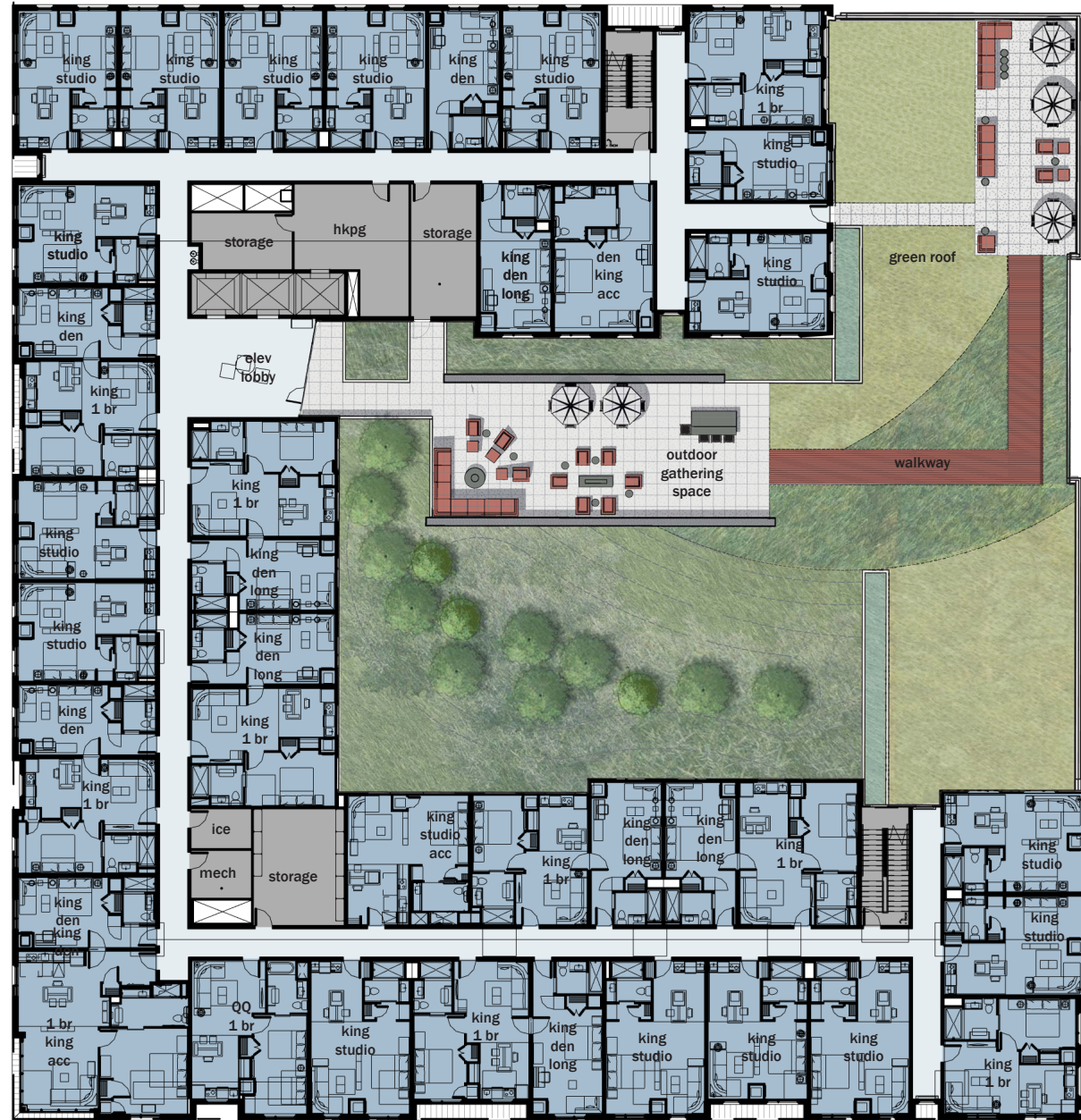

SW RIVER PARKWAY

THE STRAND

SW HALL STREET

MINT URBAN APARTMENTS

SW RIVER DRIVE

SW MOODY AVE

DAVID EVANS AND ASSOCIATES

SW RIVER PARKWAY



MINT URBAN APARTMENTS

SW RIVER DRIVE

THE STRAND

SW HALL STREET

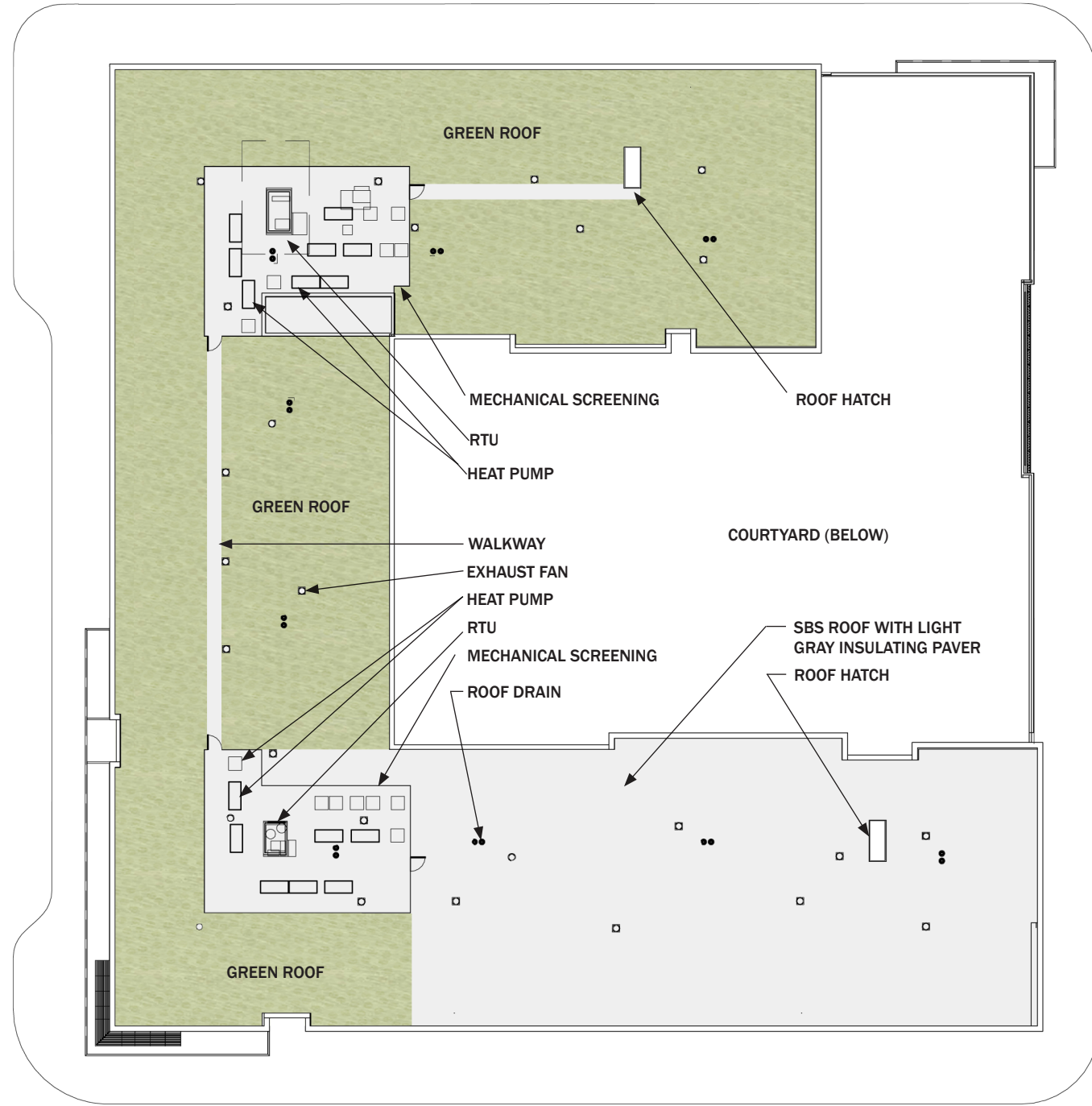

SW MOODY AVE

DAVID EVANS AND ASSOCIATES

SW RIVER PARKWAY



SOUTH ELEVATION



WEST ELEVATION

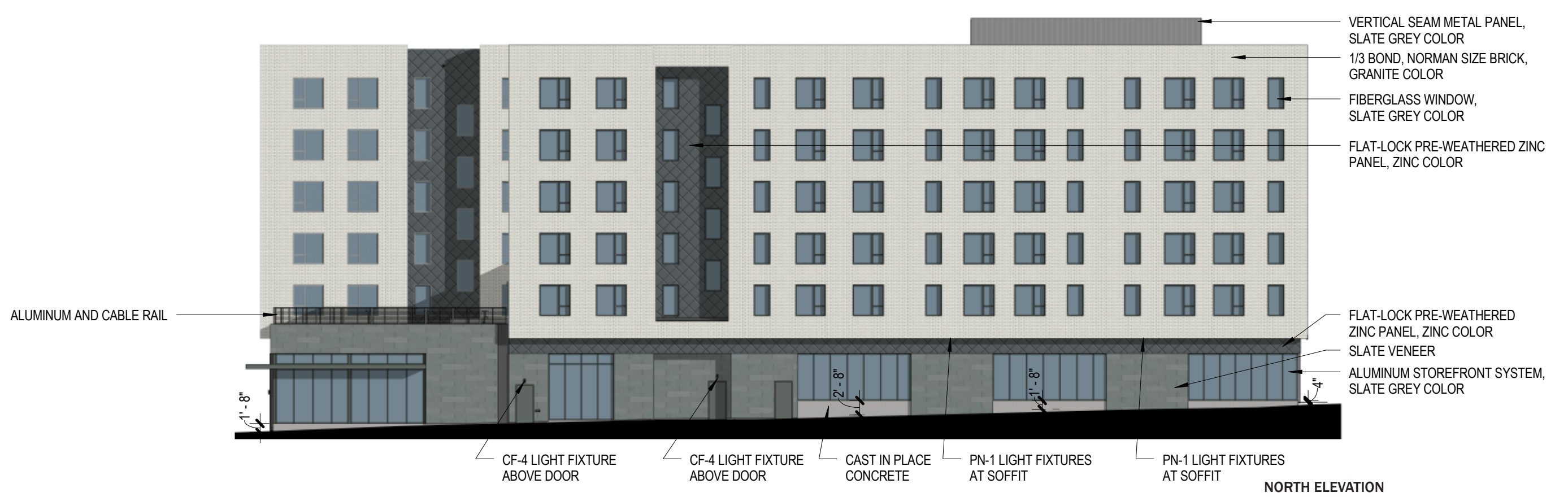
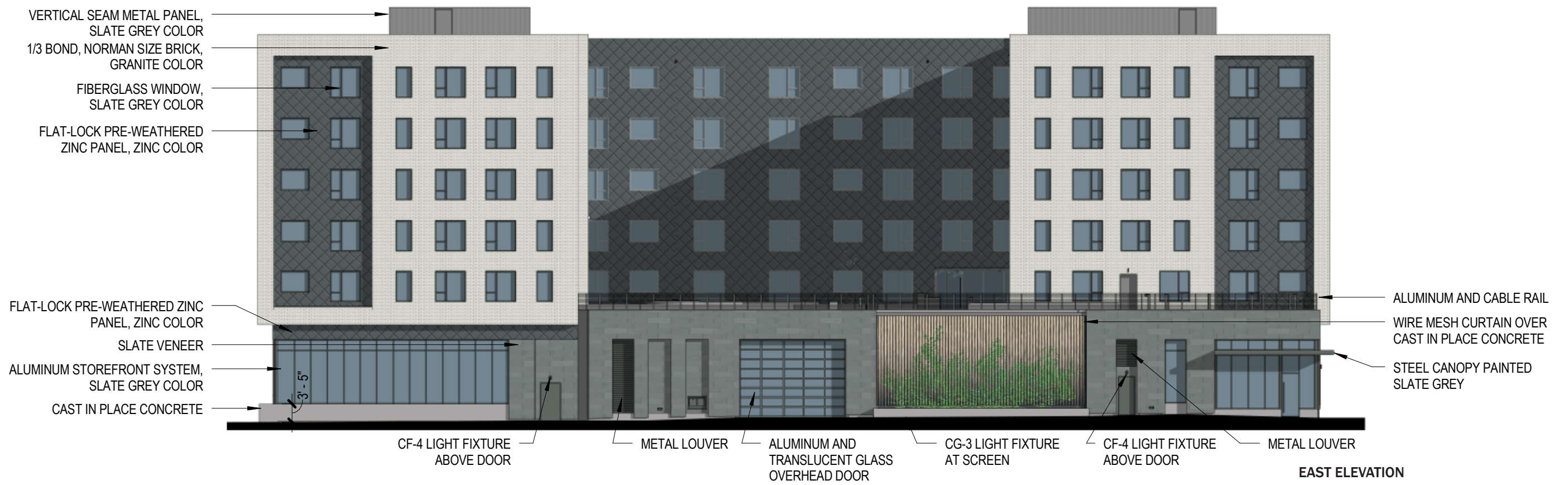

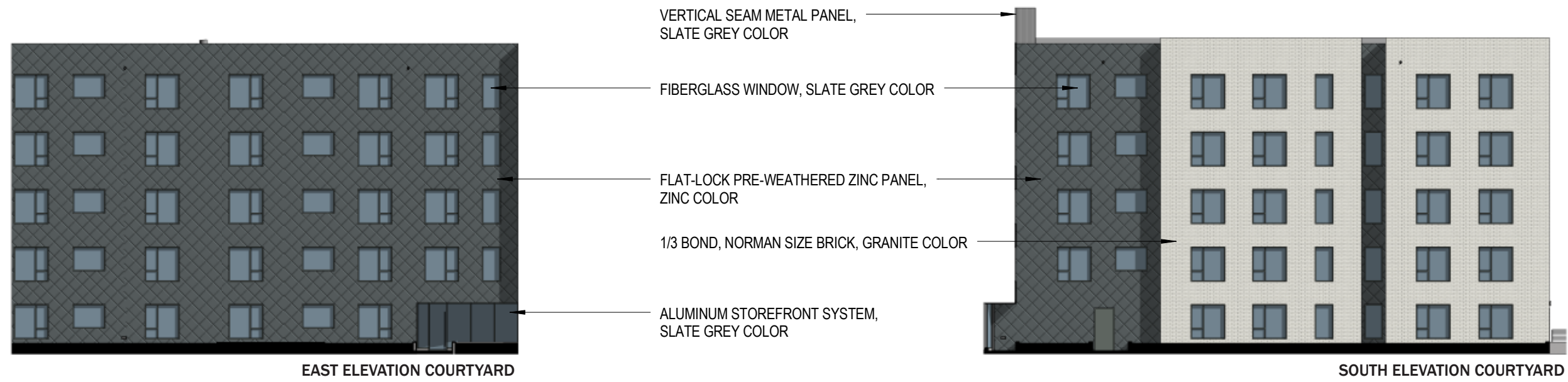



SOUTH ENLARGED ELEVATION 3
1/8" = 1'-0"

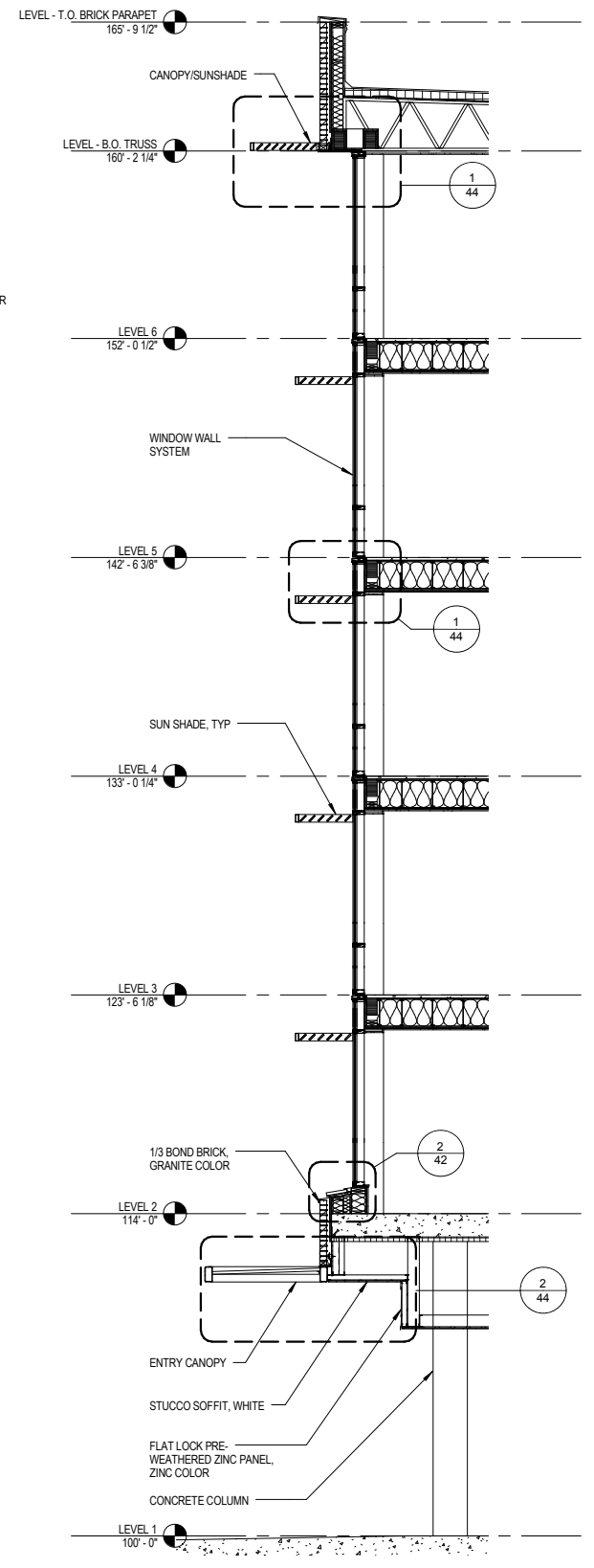

SECTION @ CURTAINWALL 2
1/8" = 1'-0"

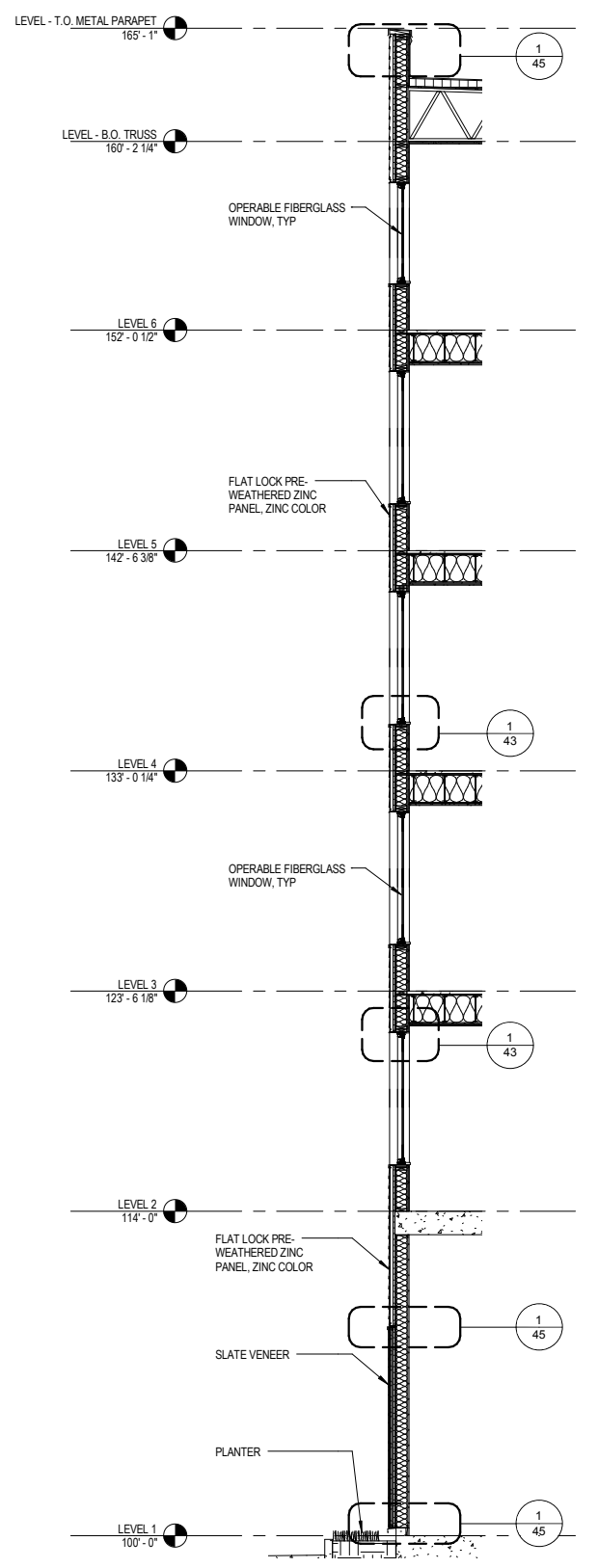

SECTION @ METAL PANEL 1
1/8" = 1'-0"

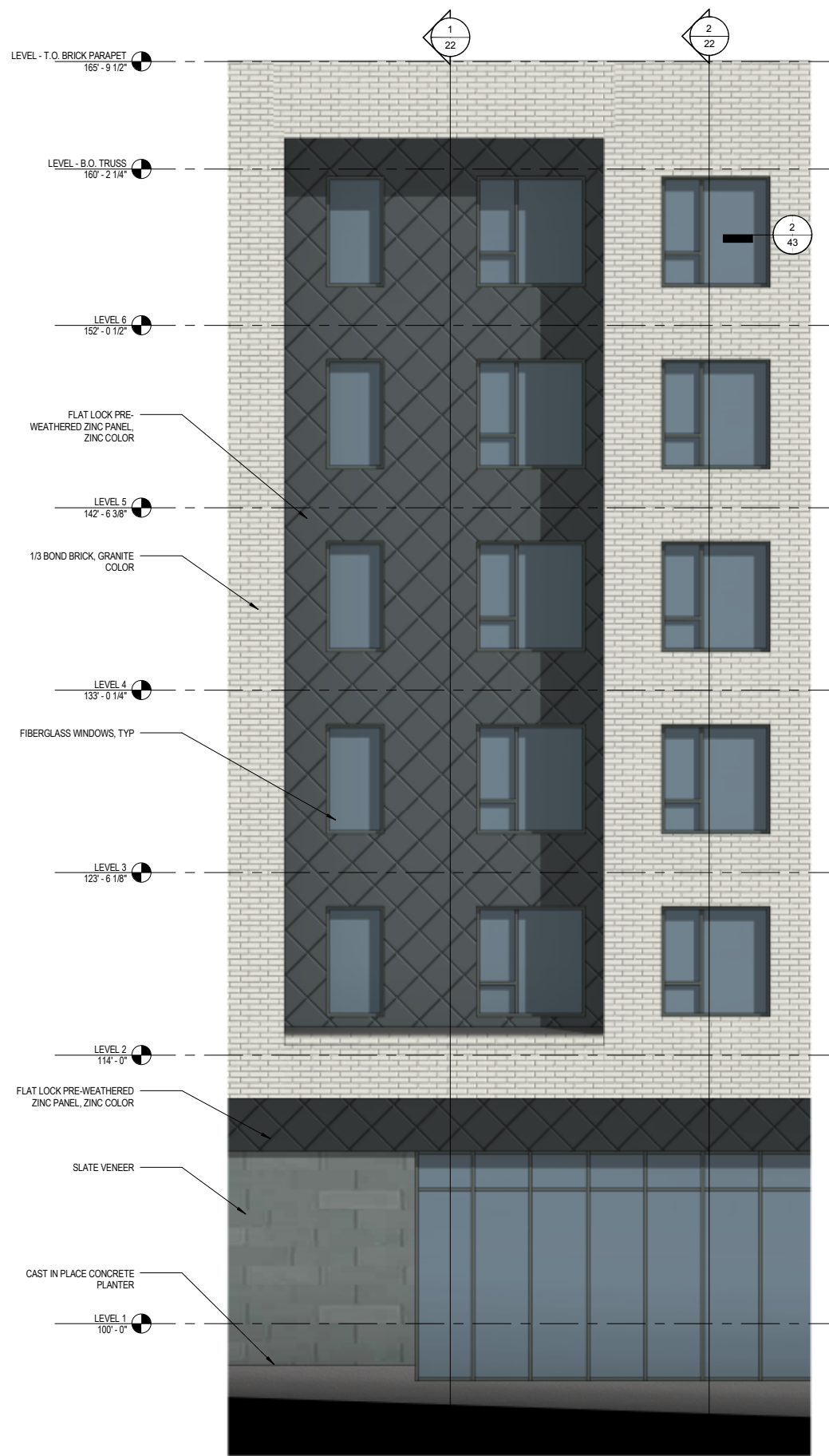

TYPICAL RECESSED BAY ENLARGED 3
1/8" = 1'-0"

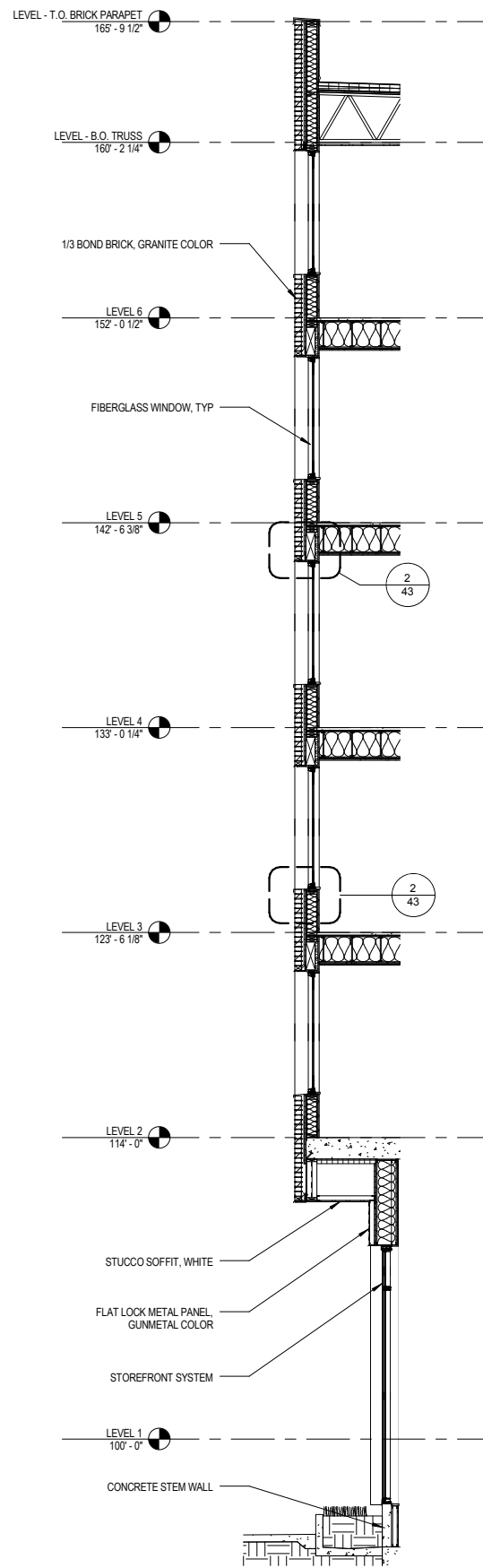

SECTION @ BRICK 2
1/8" = 1'-0"

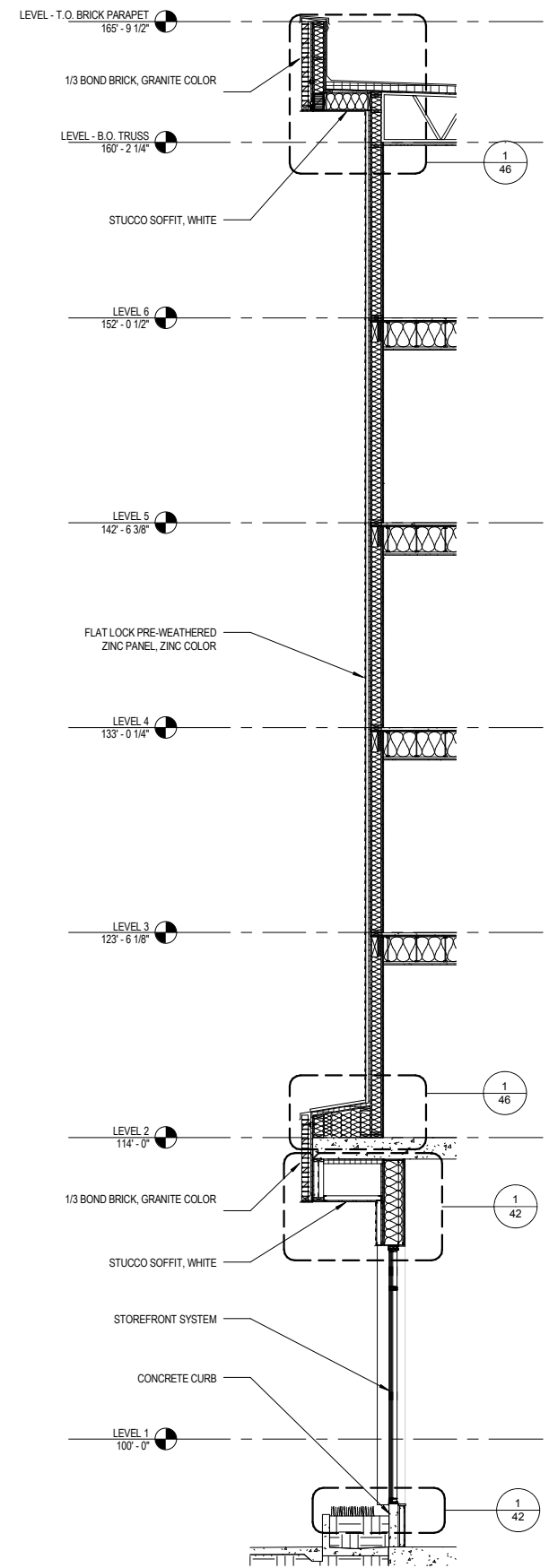

SECTION @ RECESS 1
1/8" = 1'-0"

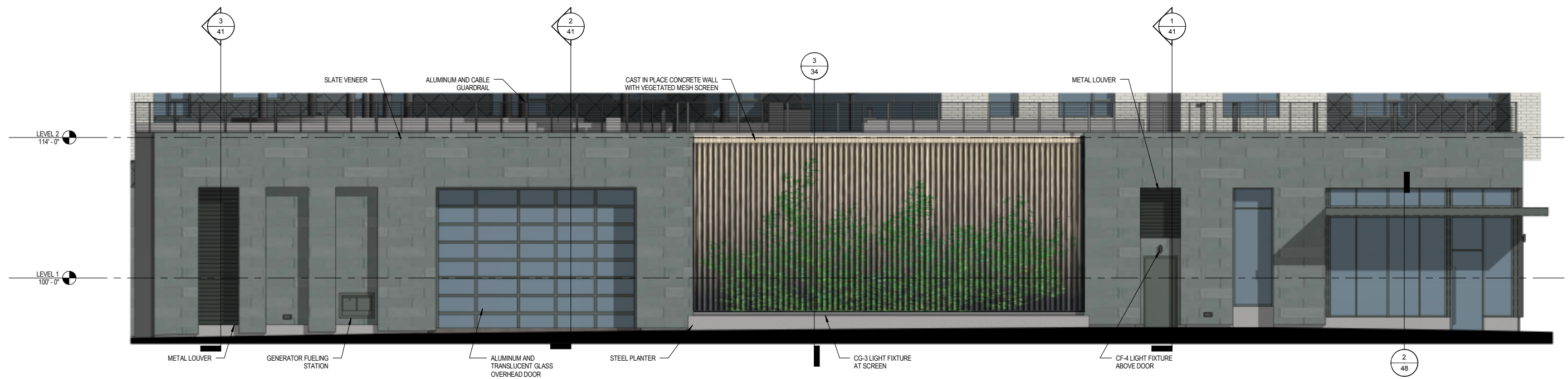

PLANTER WALL ELEVATION 1
 3/32" = 1'-0"







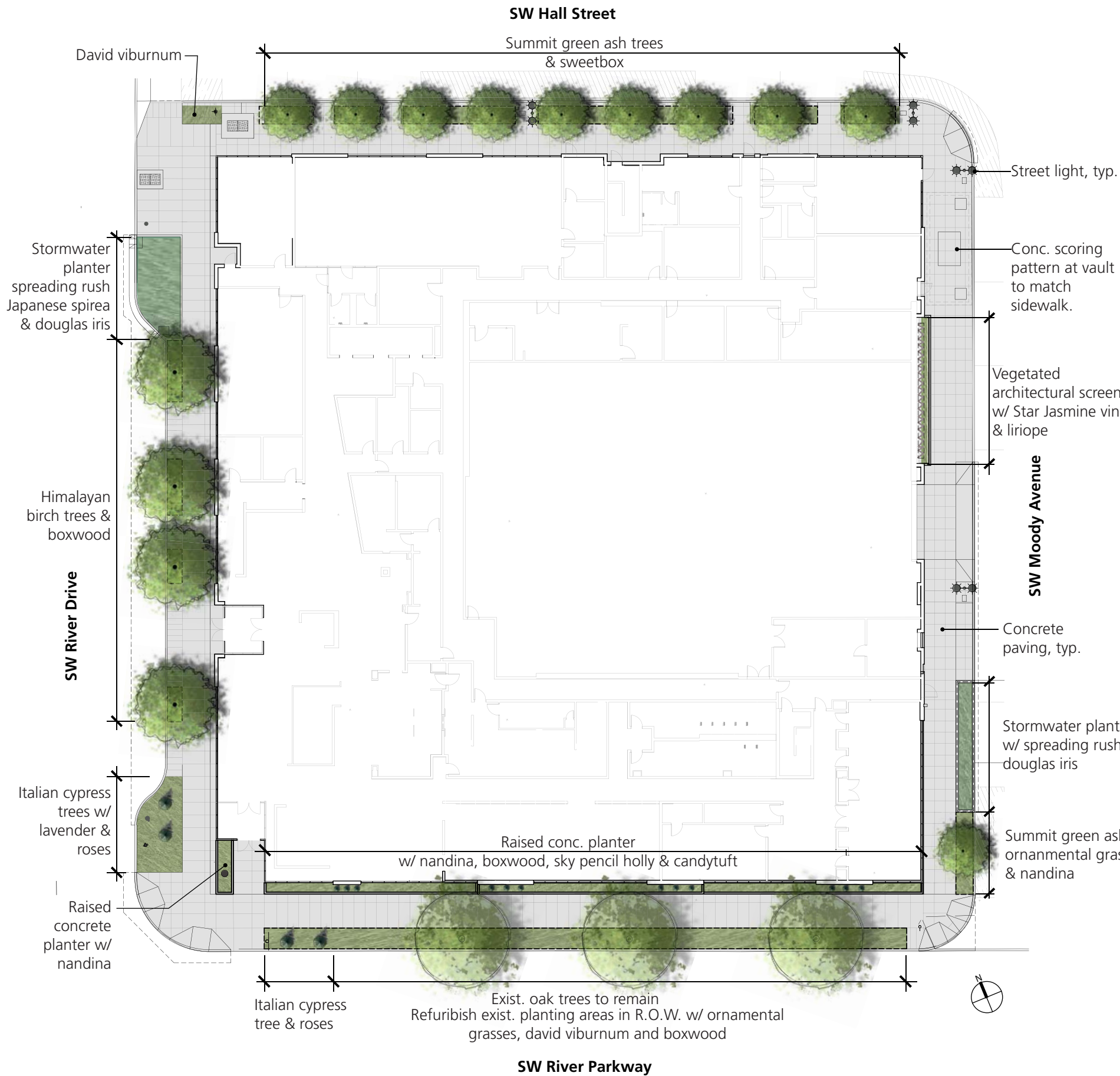

SE River Drive



SW Entry



SE River Parkway



SW Moody



SW Hall



Architectural screen



Stormwater planter

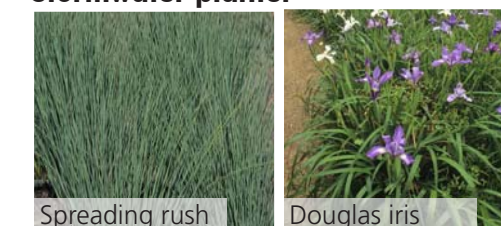



Italian cypress tree

Concrete raised planter, stepped, typ.

Exist. tree to remain & refurbished planting area (plants proposed in R.O.W. not shown for clarity), typ.

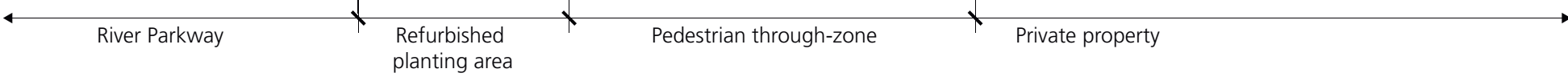
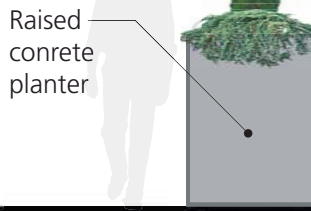
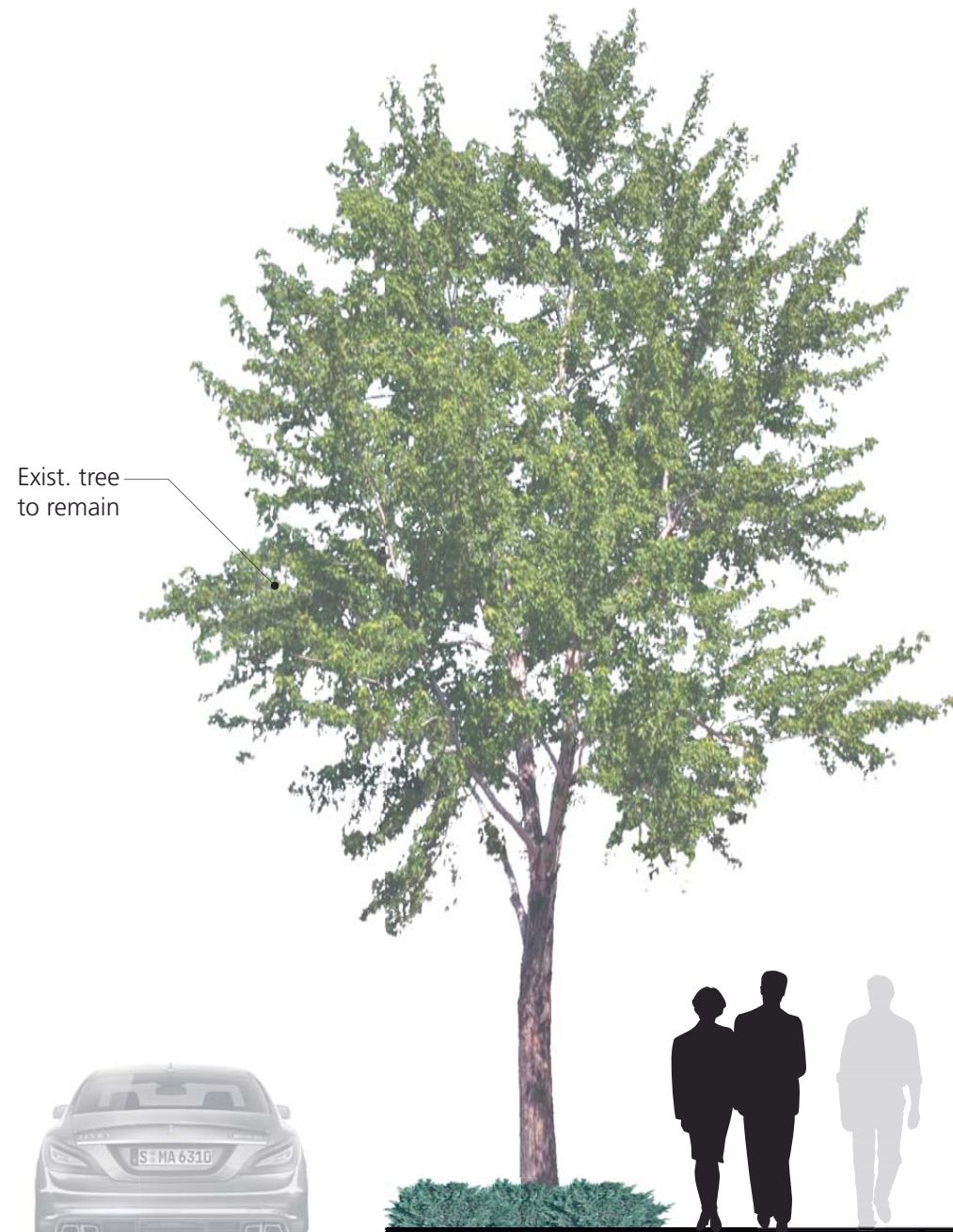



Architectural screen
& Star jasmine vine
in steel planter

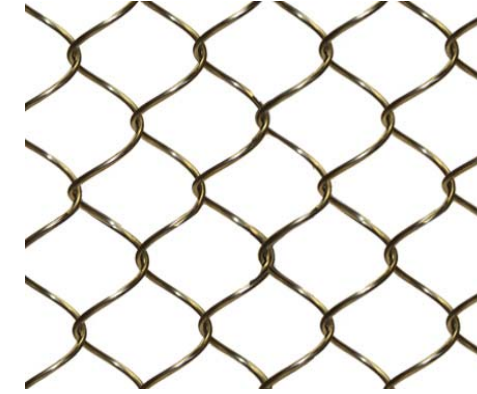
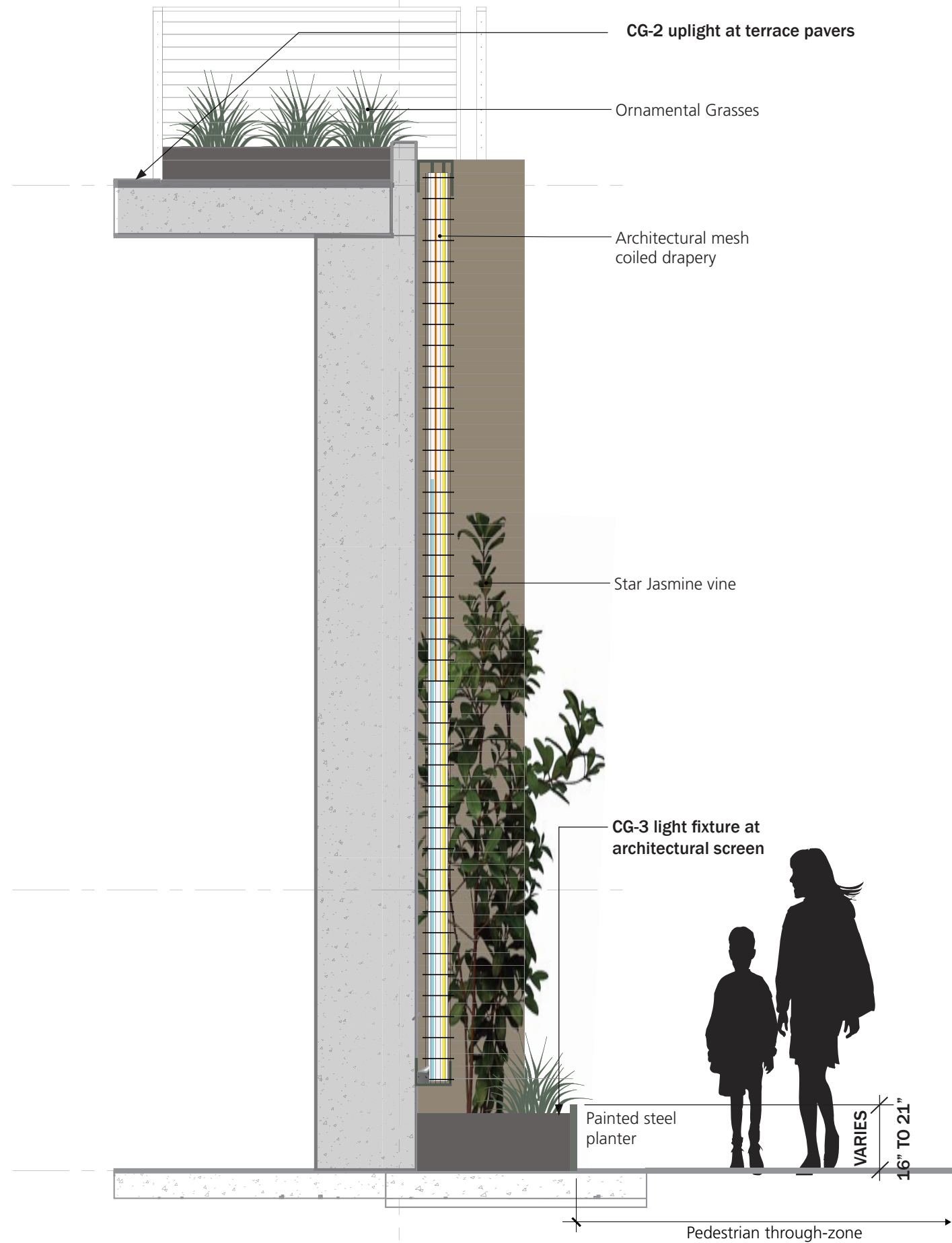

COILED WIRE MESH

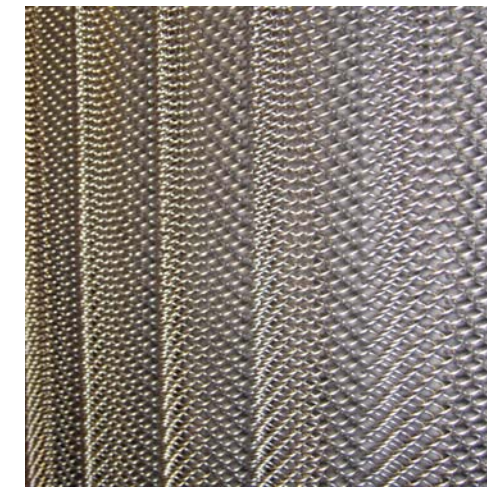

CURVING COILED WIRE MESH

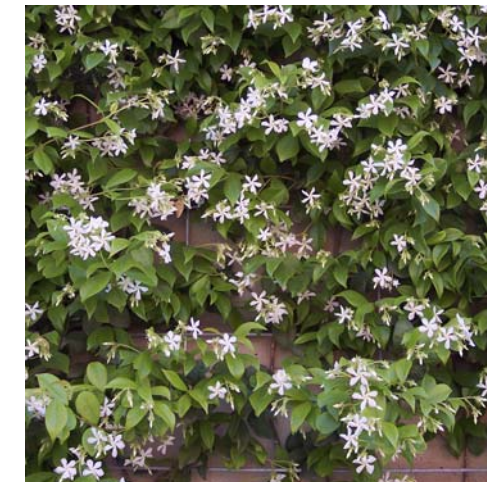

STAR JASMINE VINE





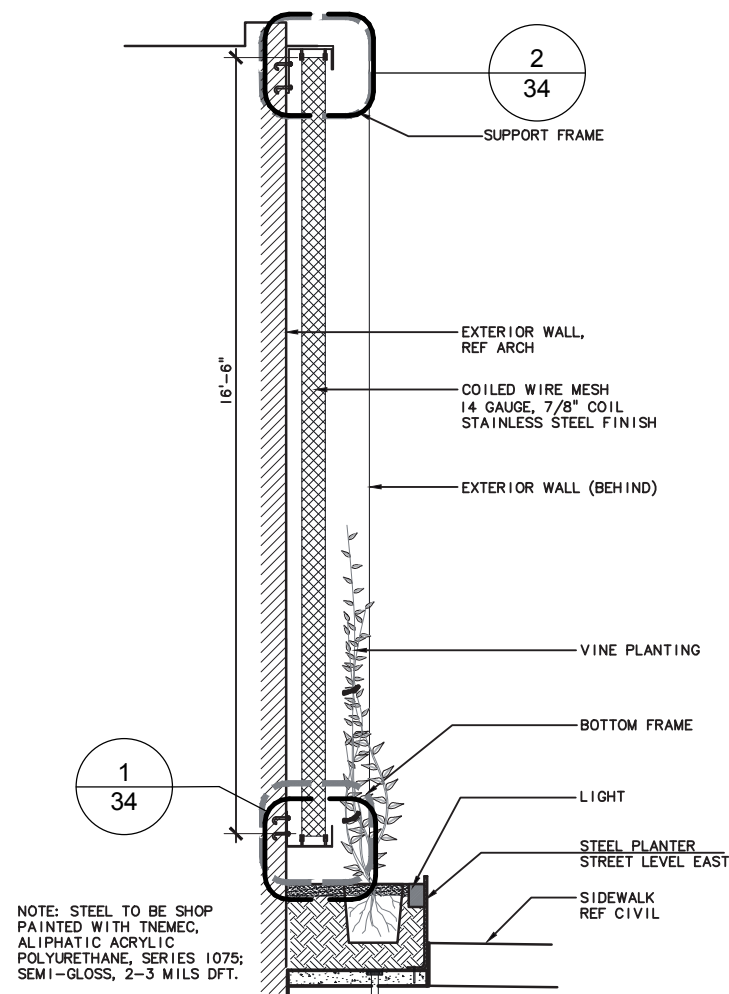

SCREEN WALL

1/4" = 1'-0"

3

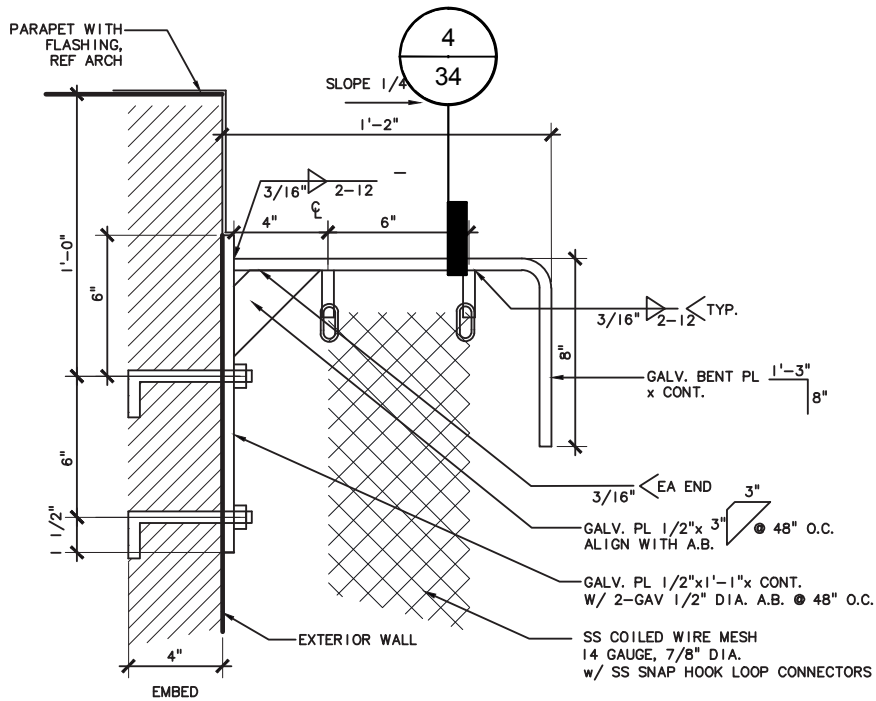

SCREEN @ HEAD

1 1/2" = 1'-0"

2

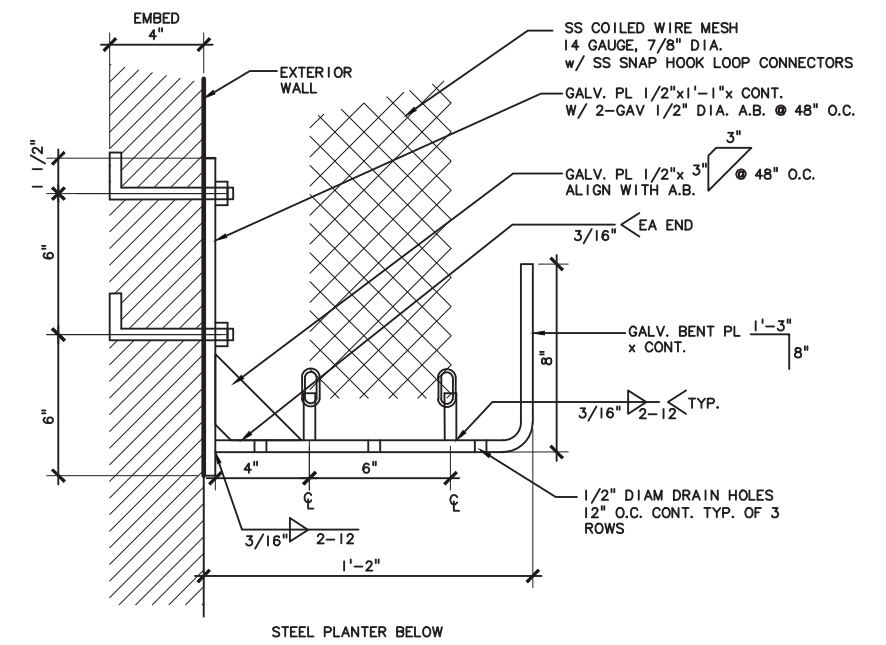

SCREEN @ BASE

1 1/2" = 1'-0"

1

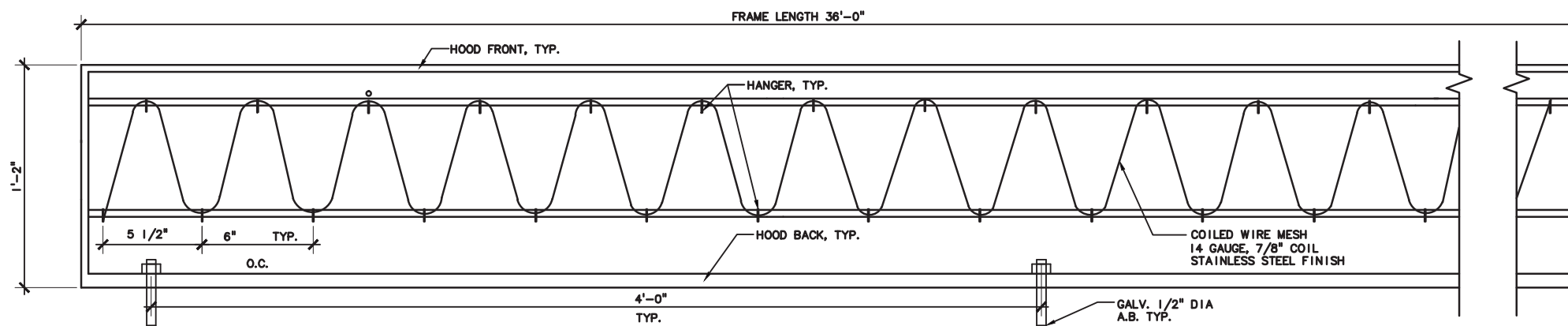

SCREEN PLAN DETAIL

1 1/2" = 1'-0"

5

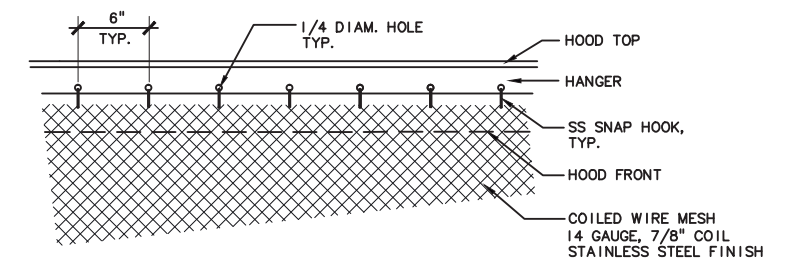

SCREEN HANGERS

3/4" = 1'-0"

4







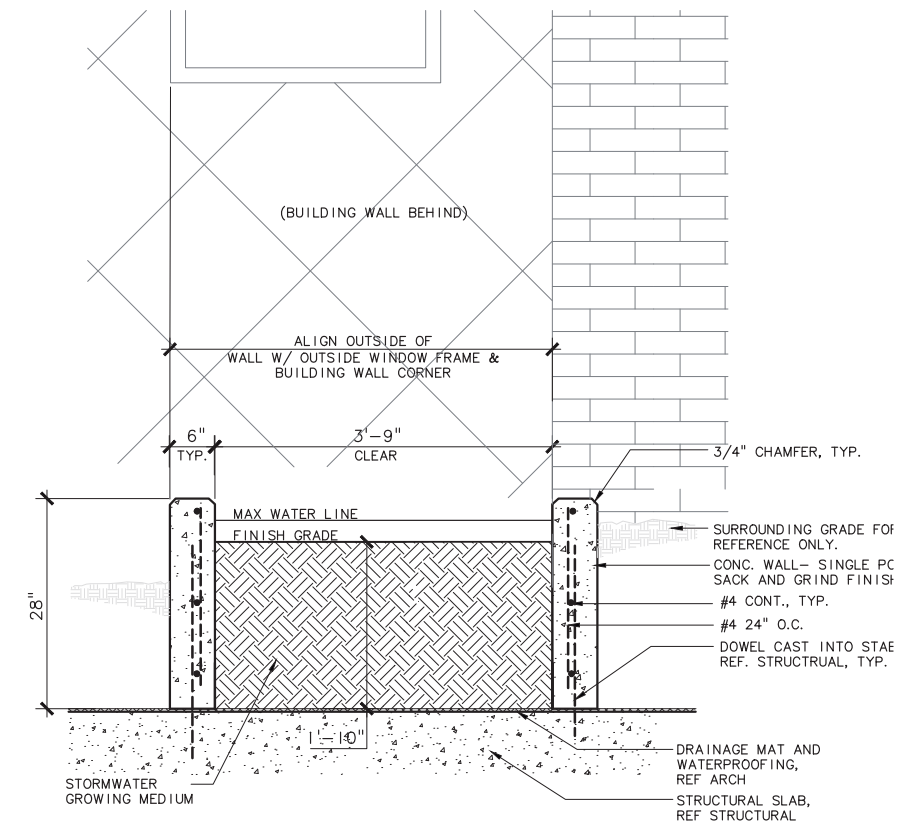
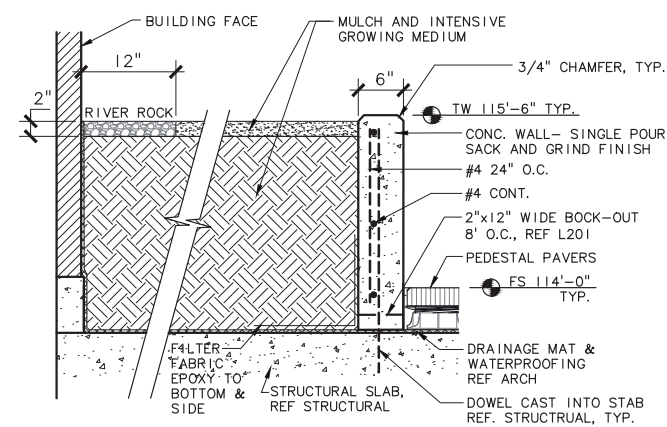
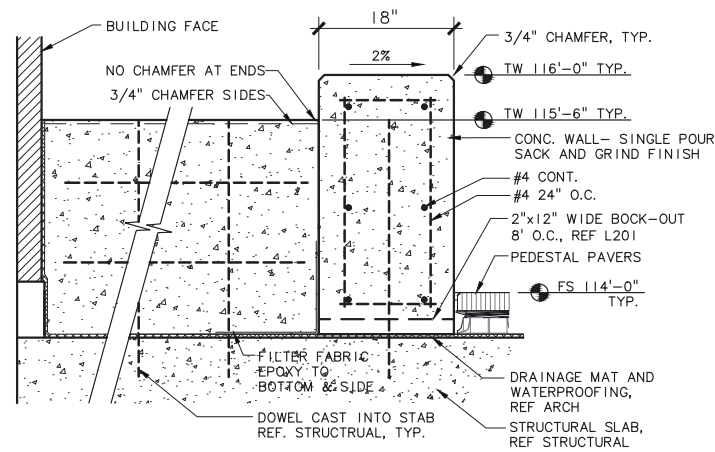

TERRACE SEAT WALL

1/2" = 1'-0"

3

TERRACE PLANTER WALL

1/2" = 1'-0"

2

TERRACE STORMWATER

1/2" = 1'-0"

1

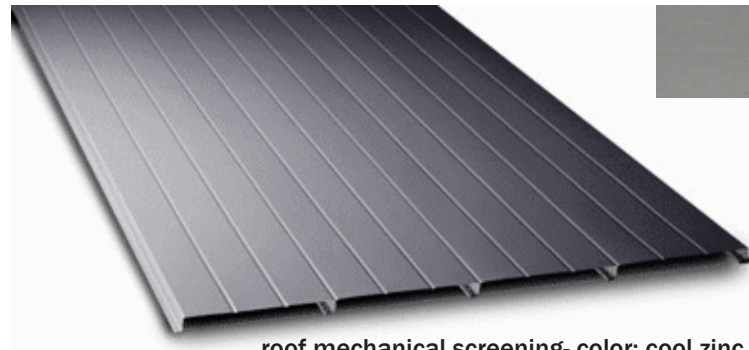

roof mechanical screening- color: cool zinc



aluminum & glass overhead door - mullion color: slate grey
glazing: translucent glass

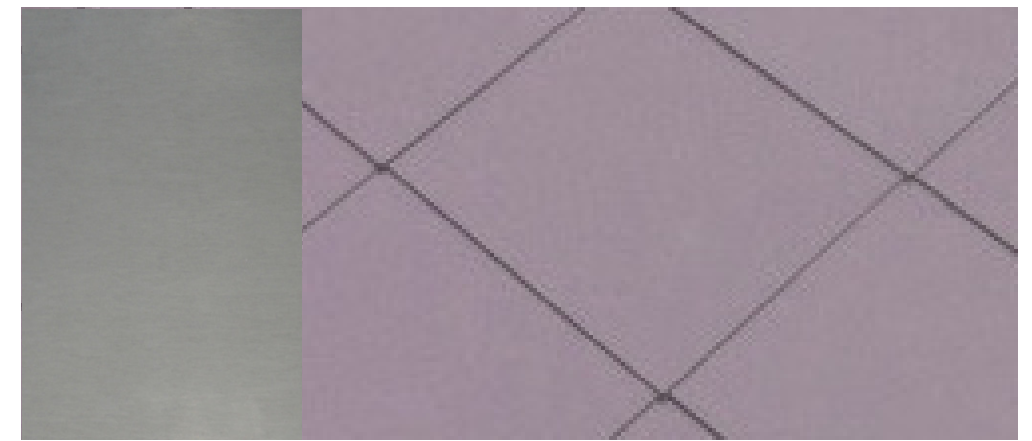

flat-lock metal panel - color: preweathered zinc



painted aluminum canopy - color: slate grey @ retail
white @ hotel entrance



painted aluminum storefront - color: slate grey



norman size brick 1/3 running bond



fiberglass window - color: slate grey

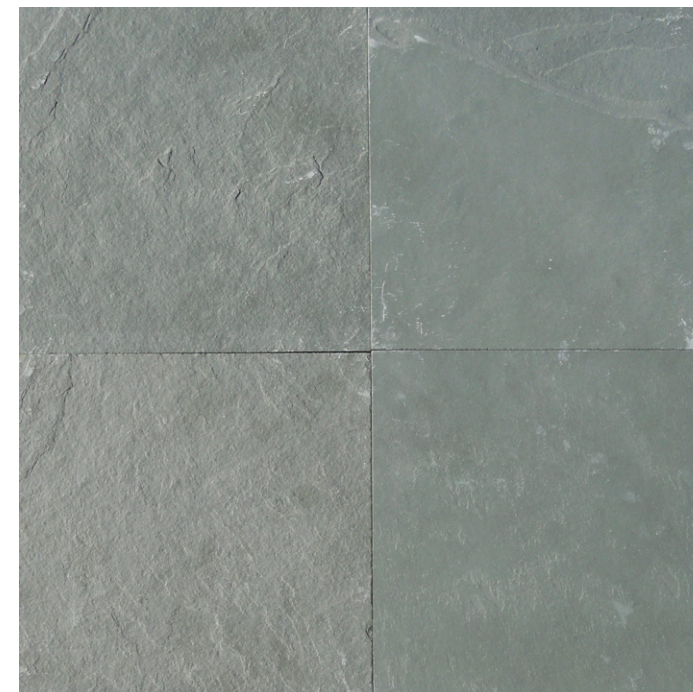

slate - Brazilian green



anodized aluminium cable rail



cast in place concrete

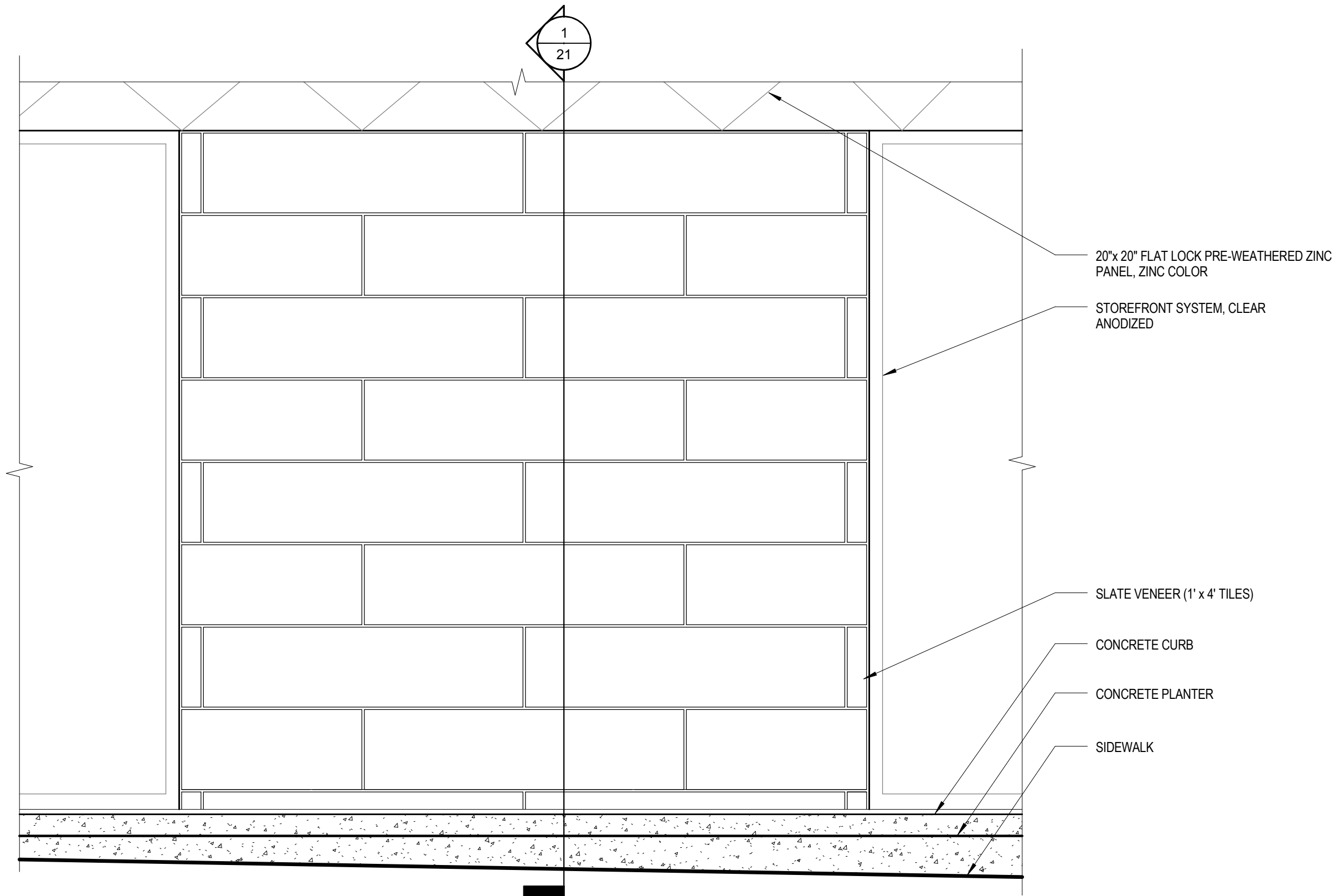

ENLARGED SLATE VENEER 1
 3/4" = 1'-0"

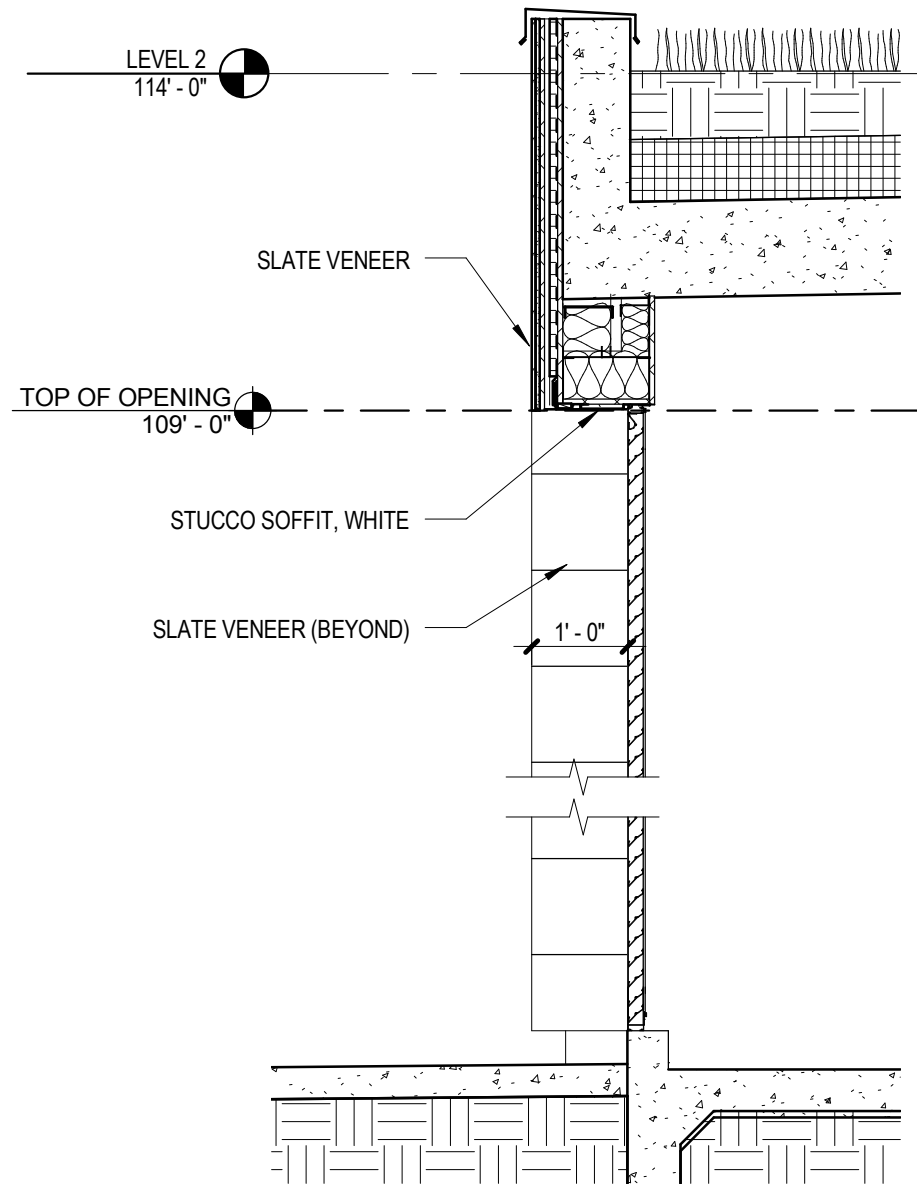

SECTION @ LOUVER

1/2" = 1'-0"

3

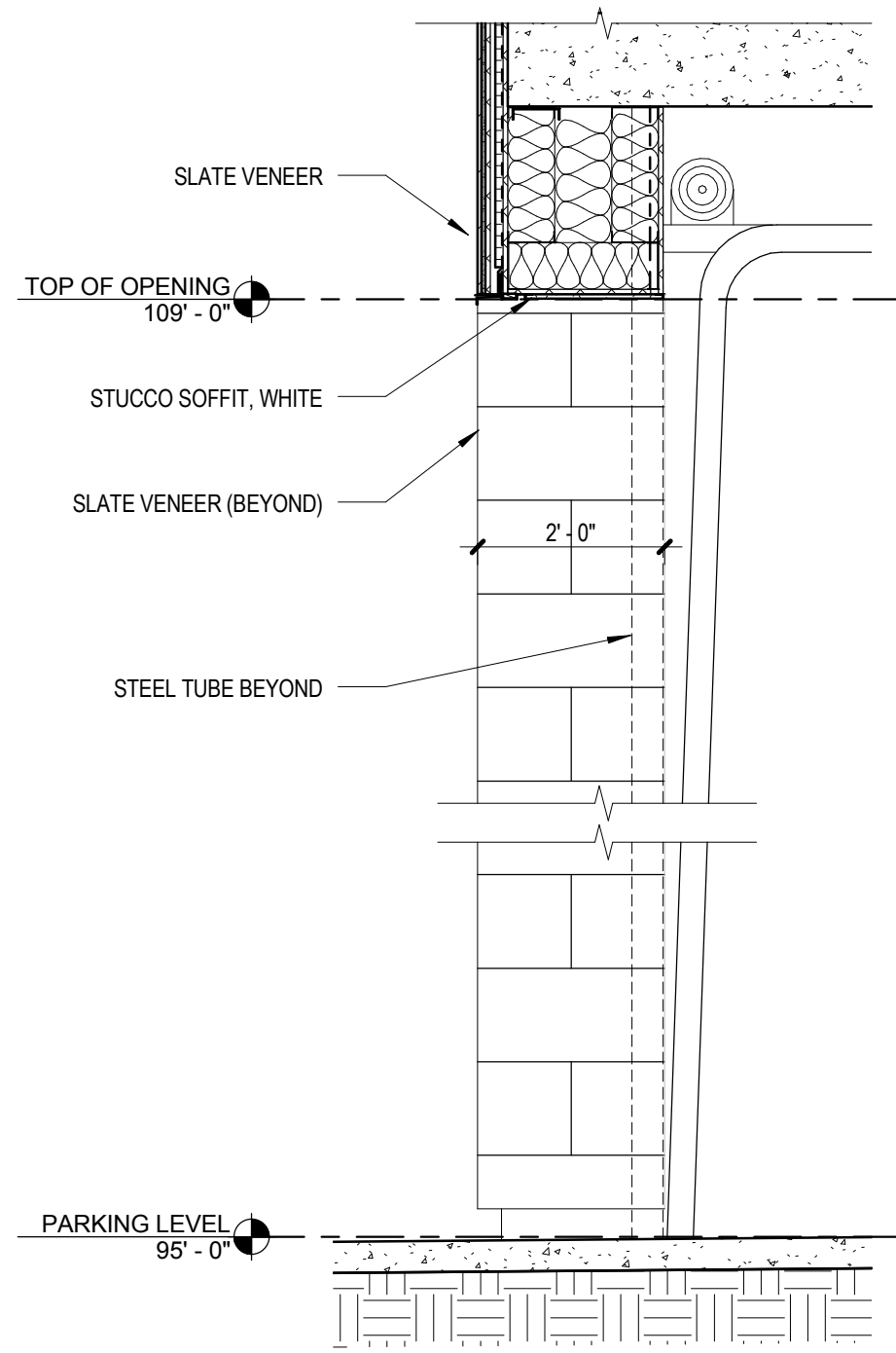

SECTION @ GARAGE ENTRY

1/2" = 1'-0"

2

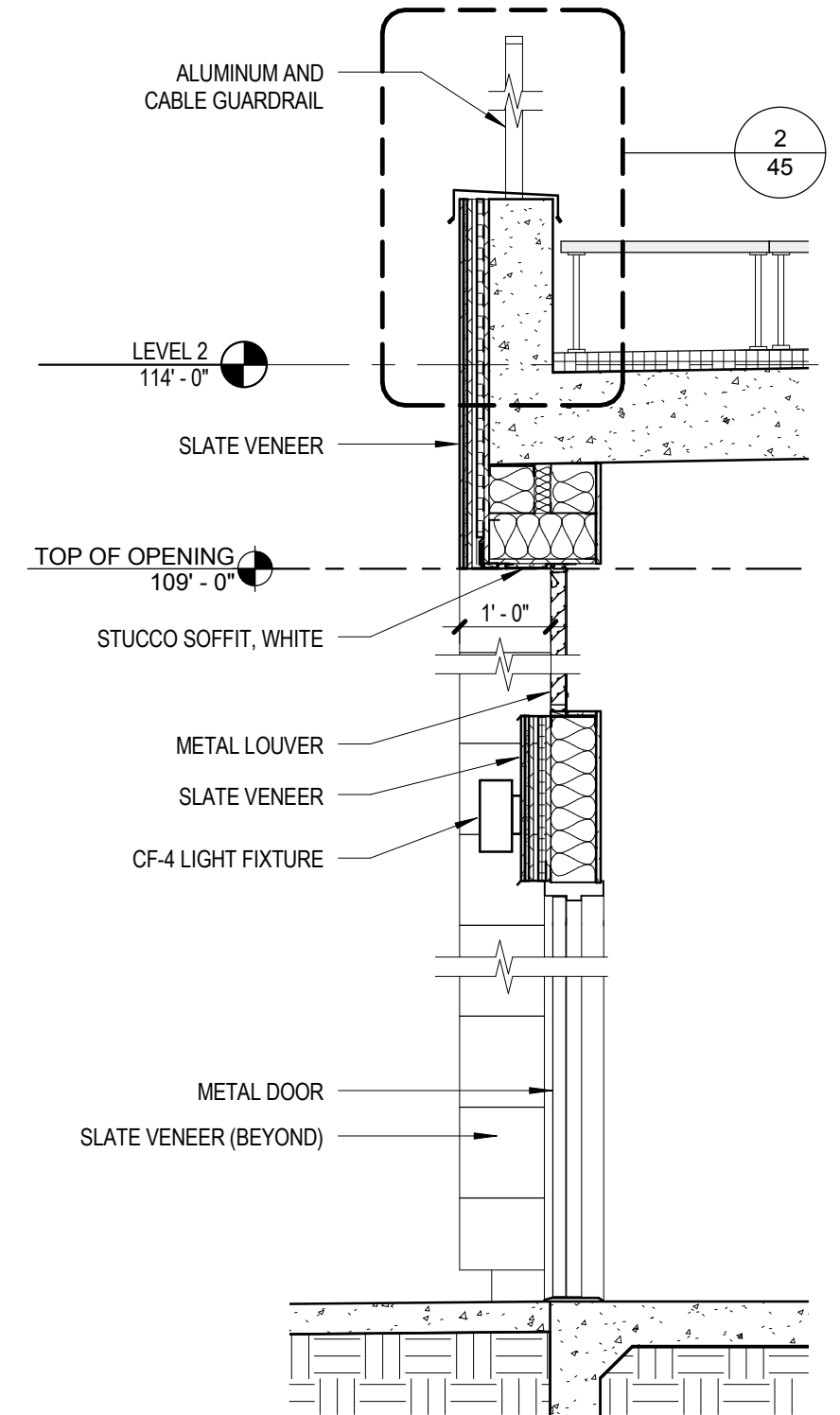

SECTION @ LOUVER

1/2" = 1'-0"

1

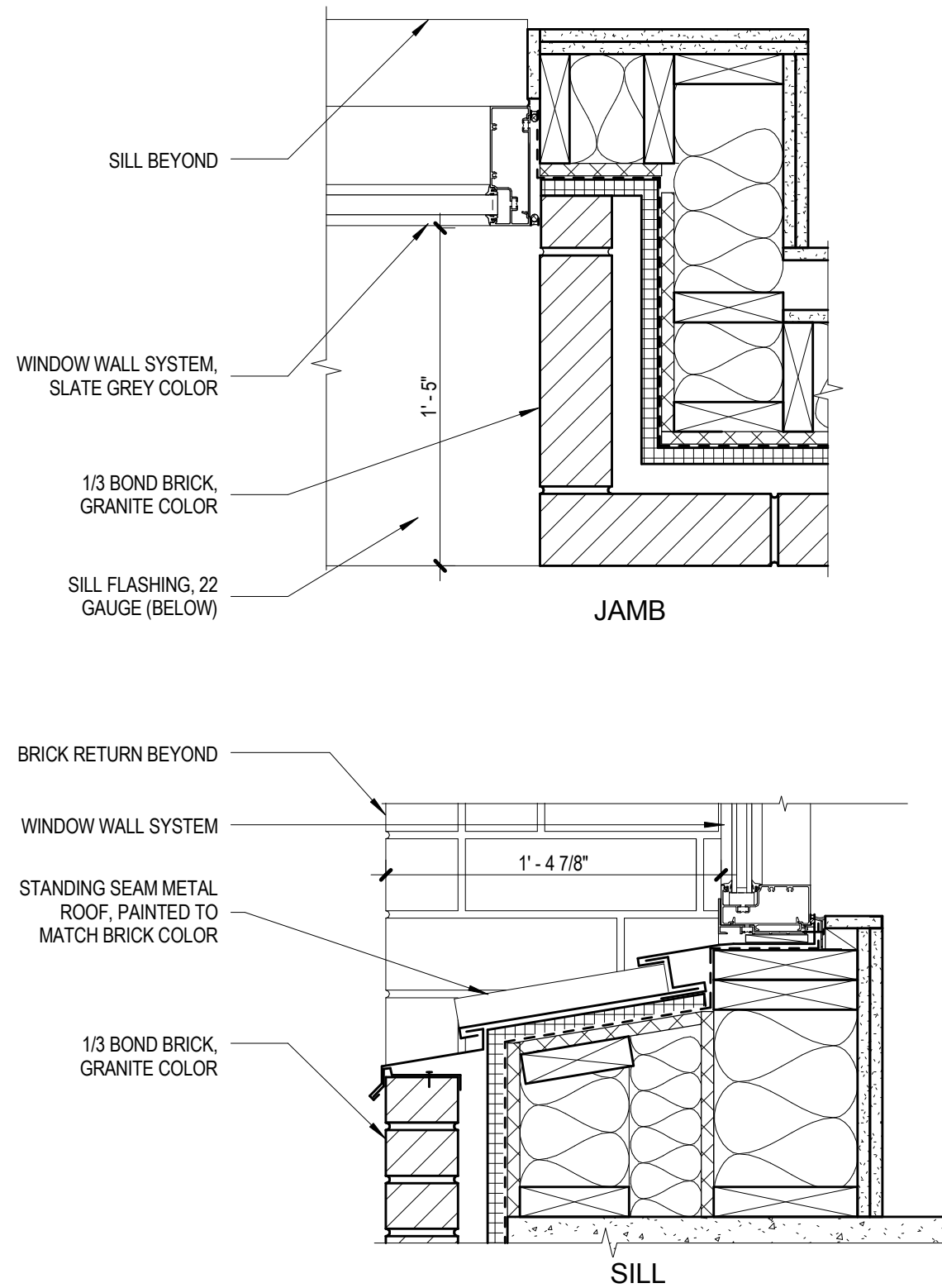

WINDOW WALL SYSTEM DETAILS

1 1/2" = 1'-0"

2

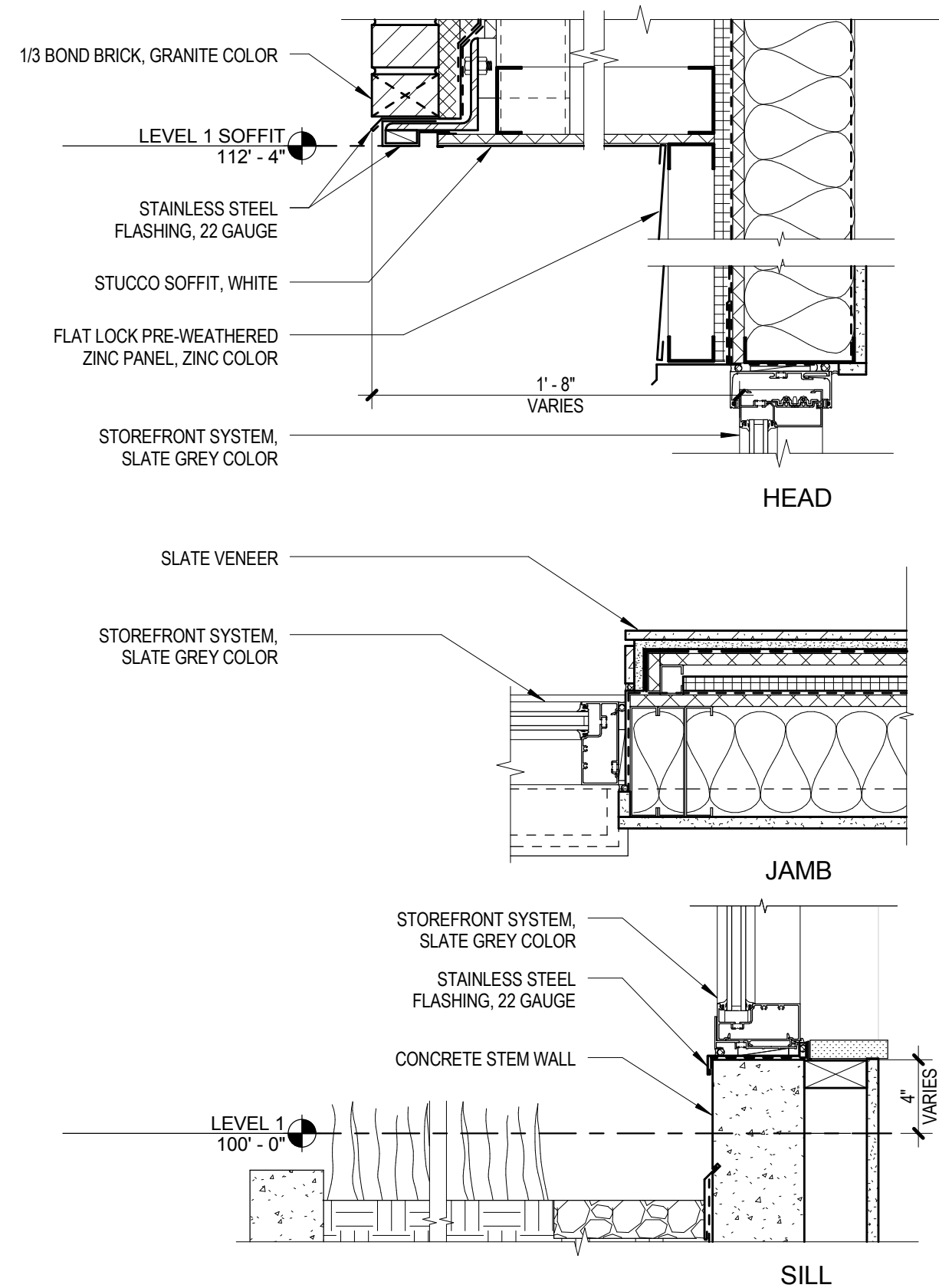

STOREFRONT DETAILS

1 1/2" = 1'-0"

1

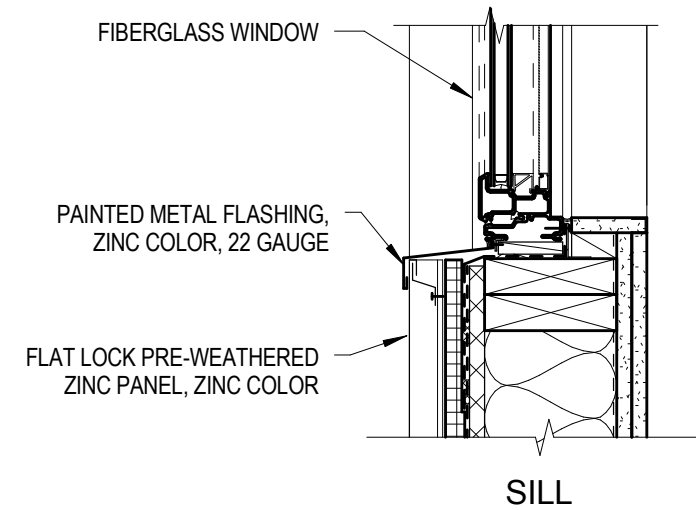
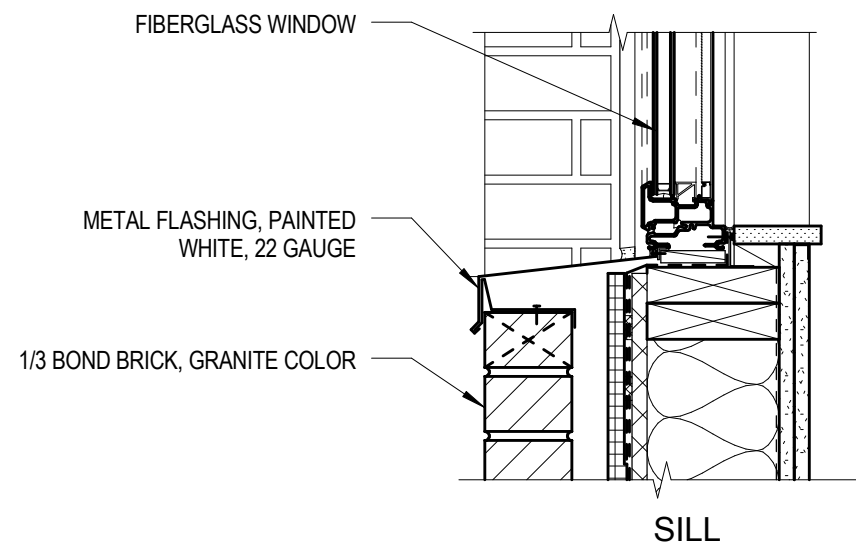
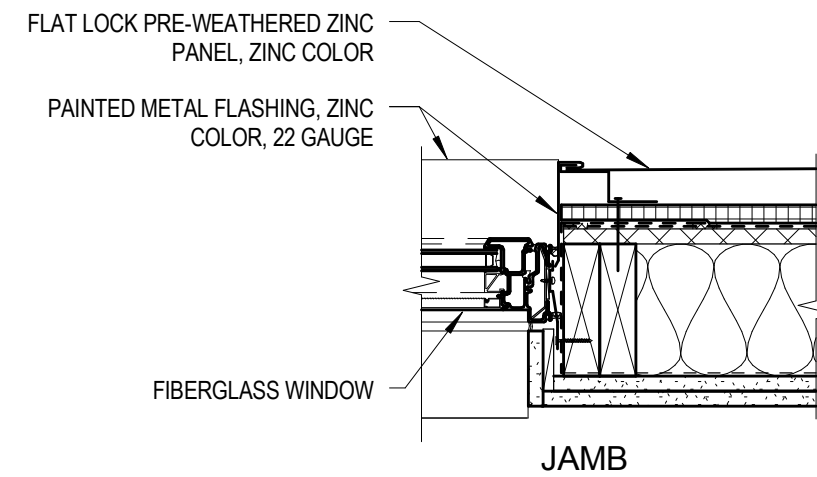
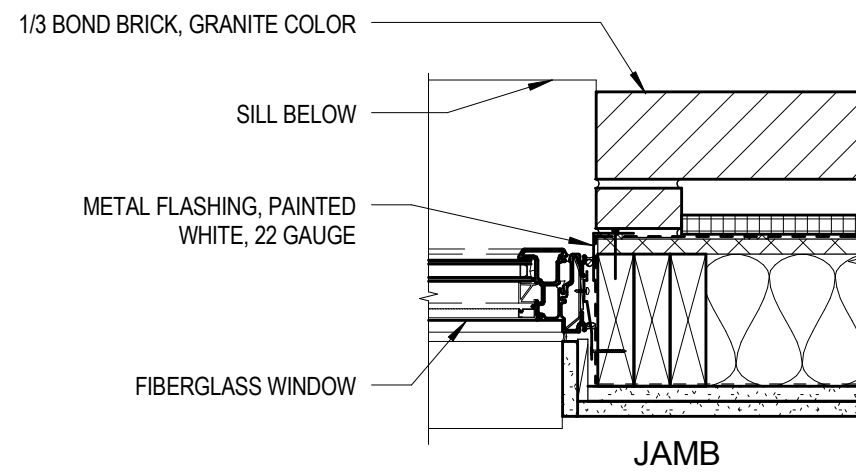
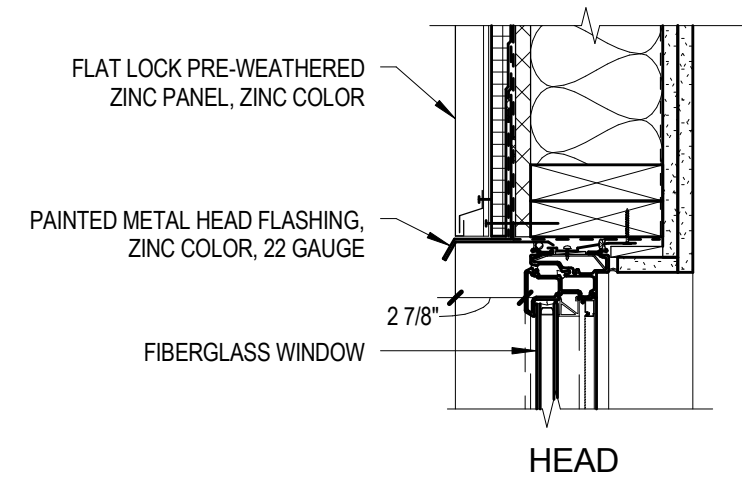
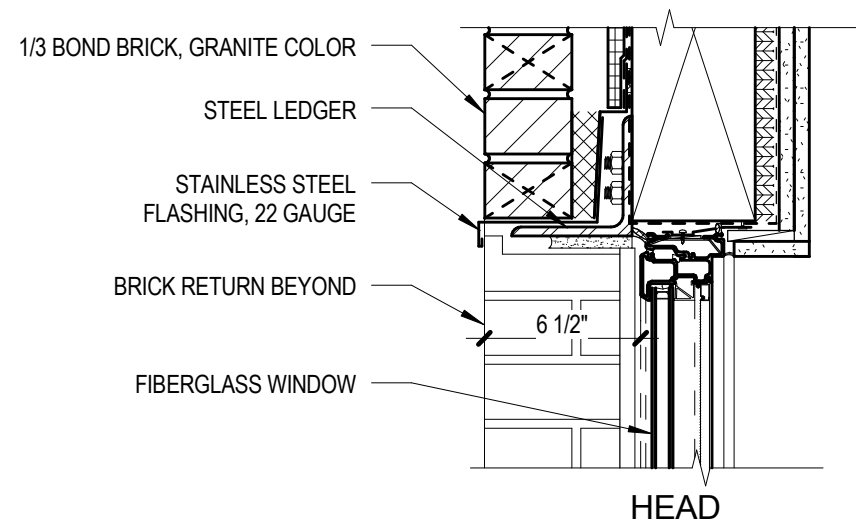

WINDOW @ BRICK 2
 1 1/2" = 1'-0"

WINDOW @ METAL PANEL 1
 1 1/2" = 1'-0"

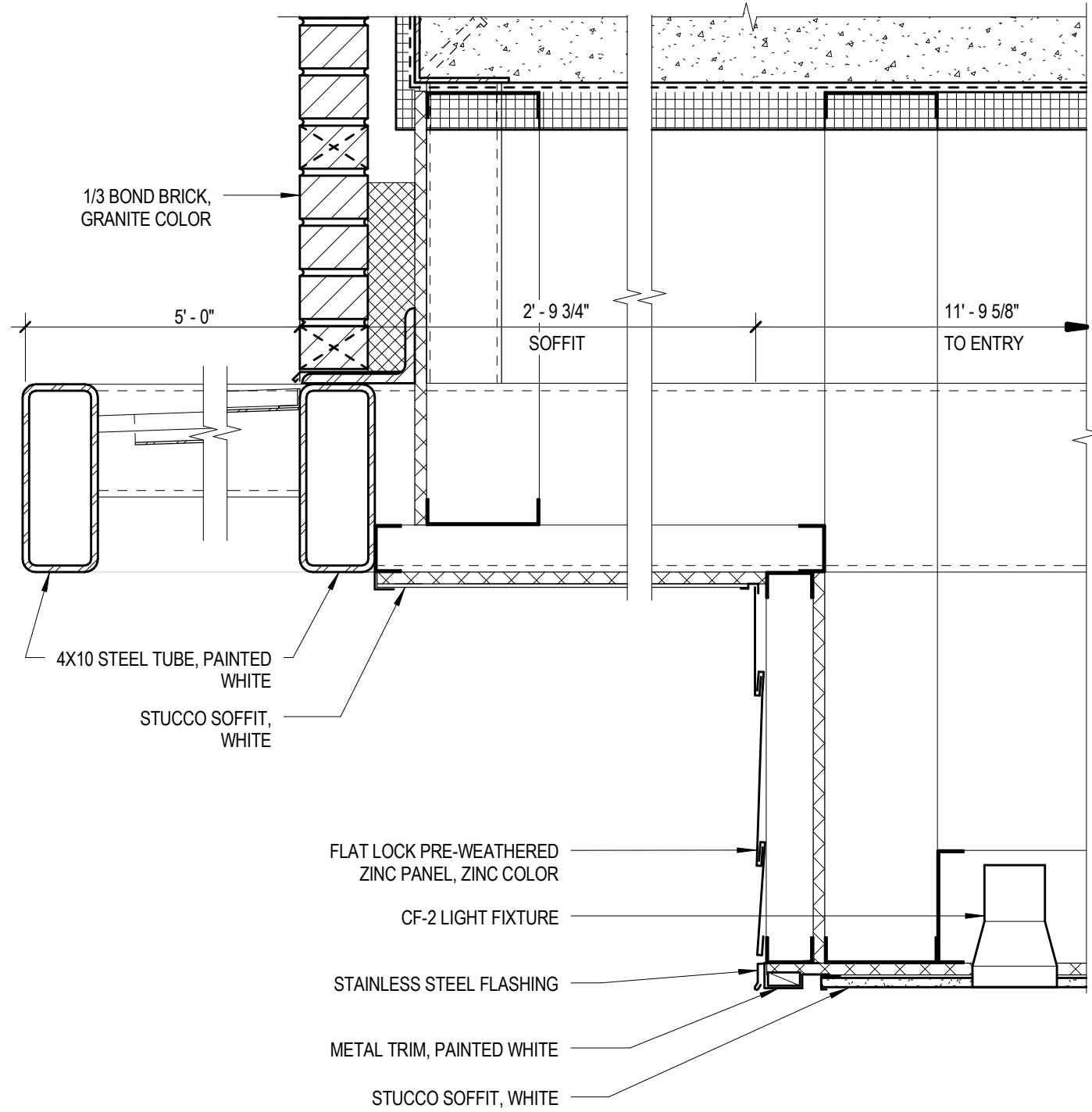

ENTRY CANOPY ②
1 1/2" = 1'-0"

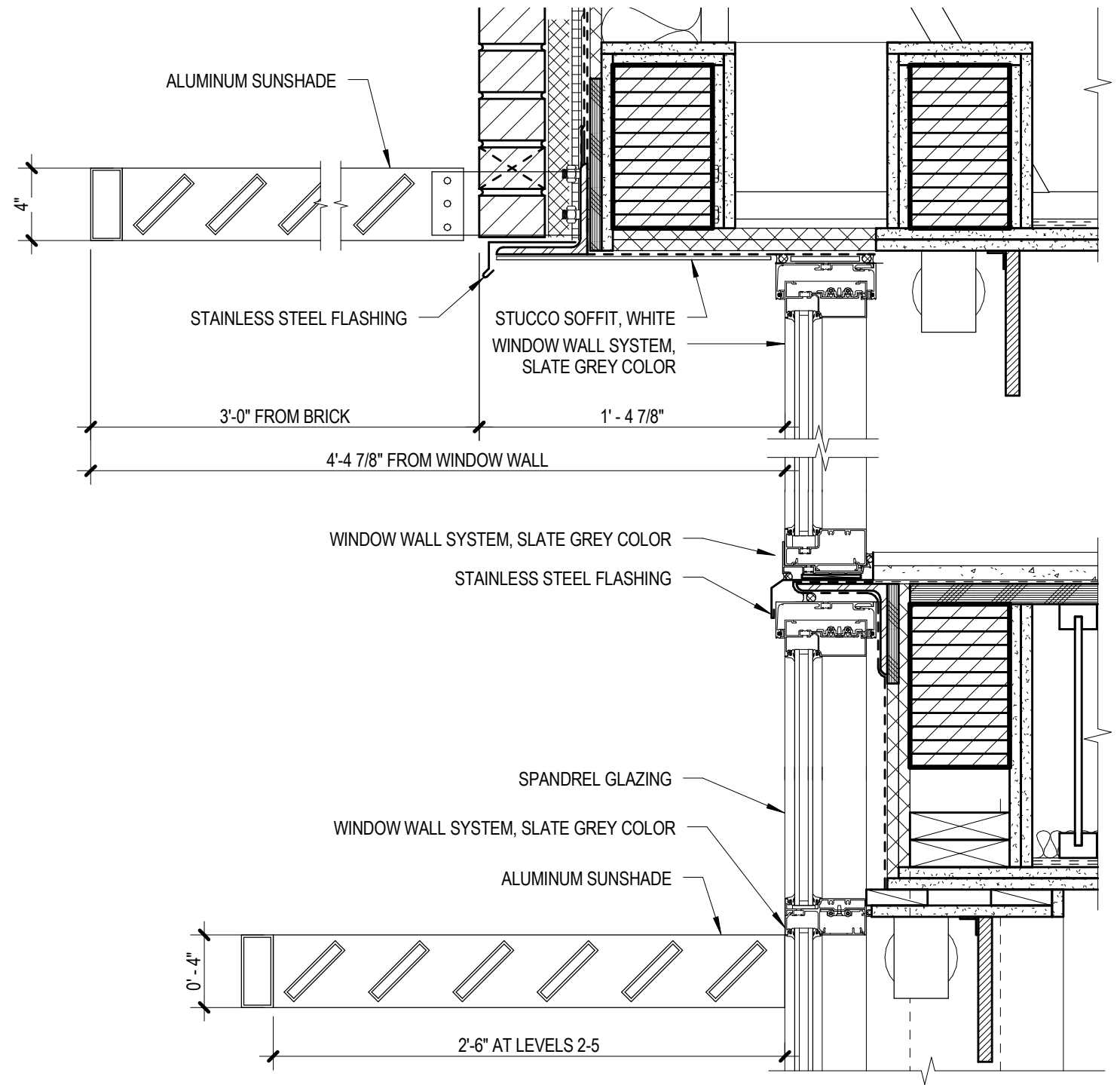

CANOPY @ WINDOW WALL ①
1 1/2" = 1'-0"

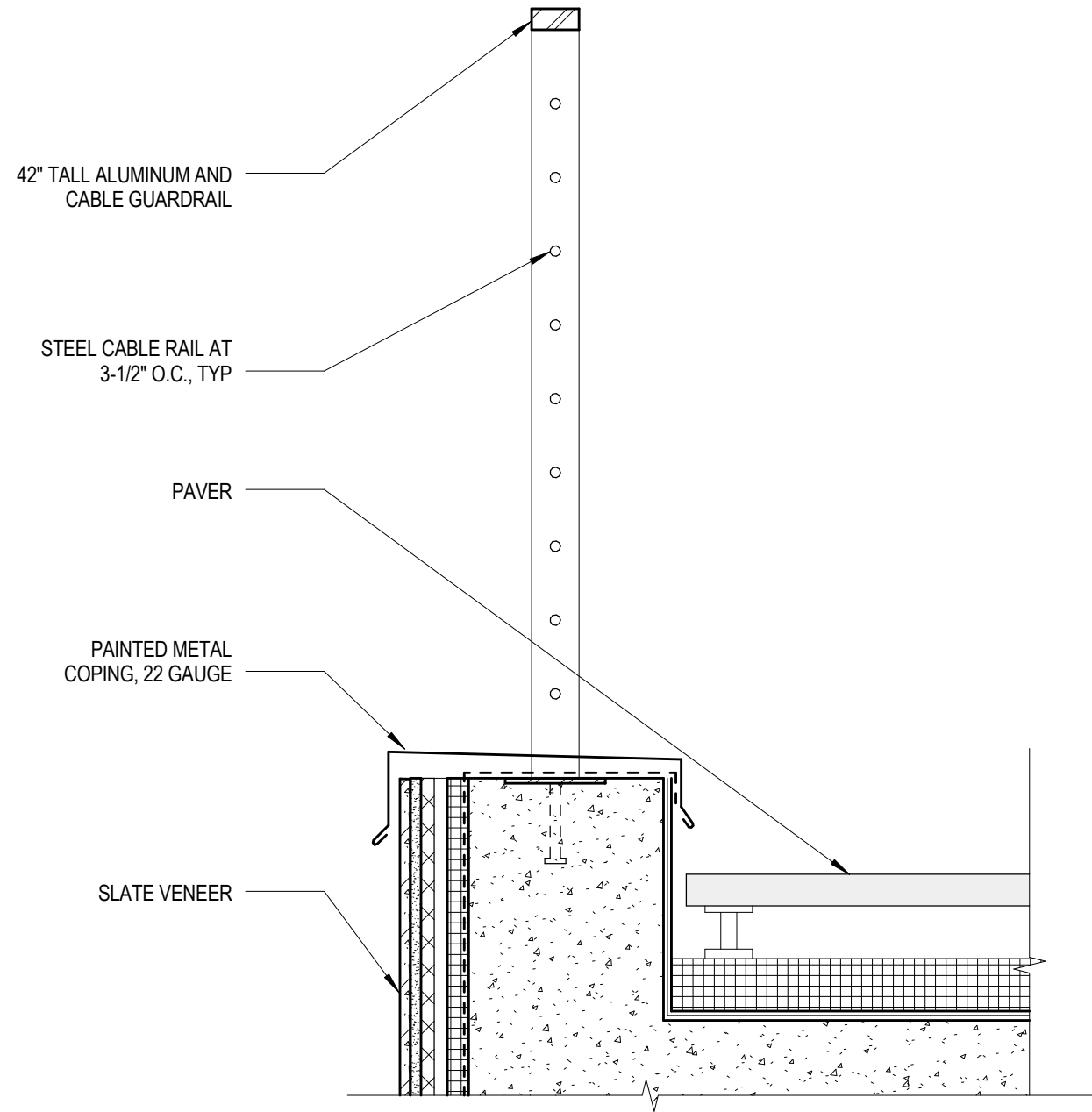

GUARDRAIL AT TERRACE ROOF 2
 1 1/2" = 1'-0"

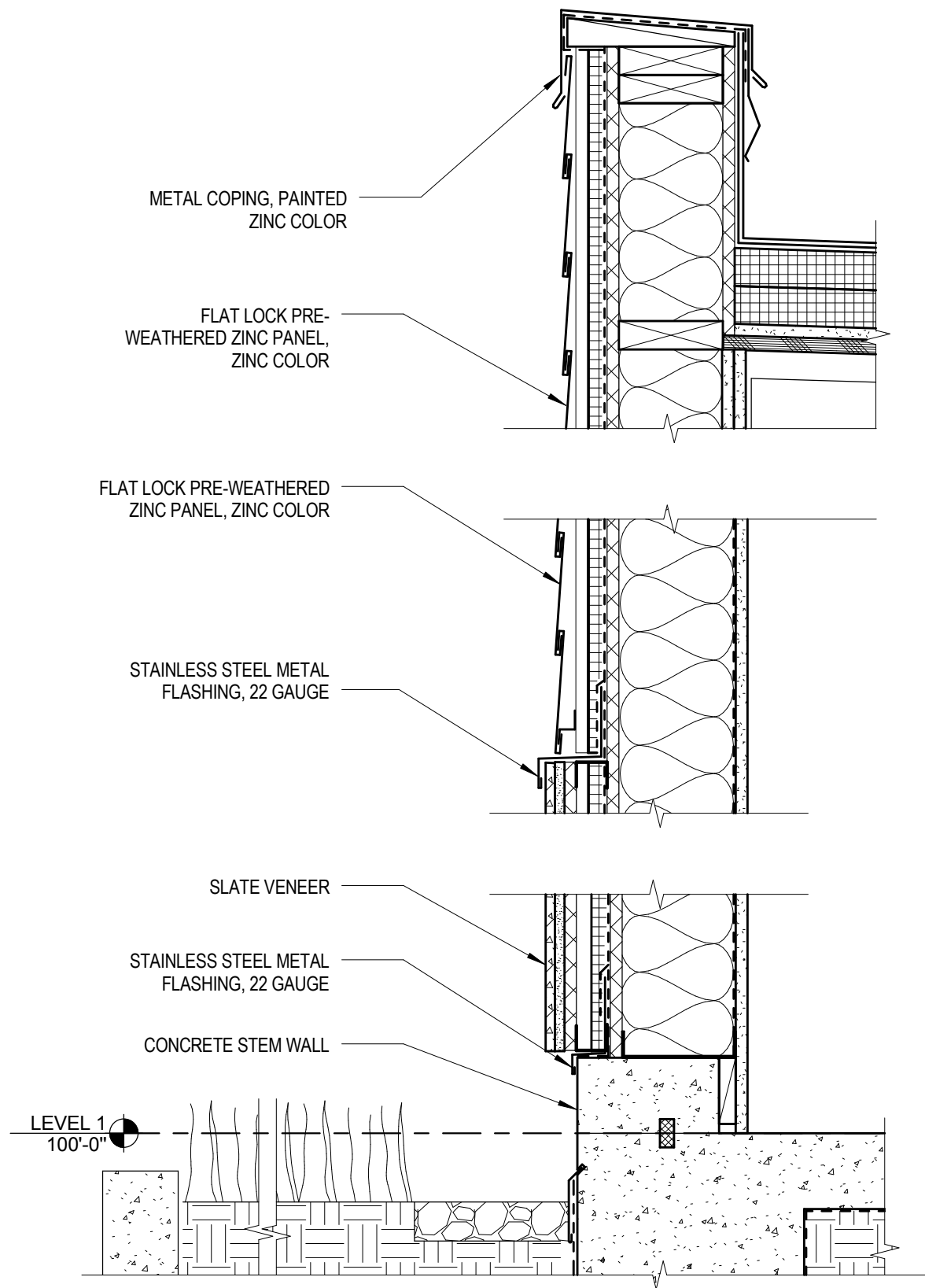

METAL PANEL SLATE TRANSITION 1
 1 1/2" = 1'-0"

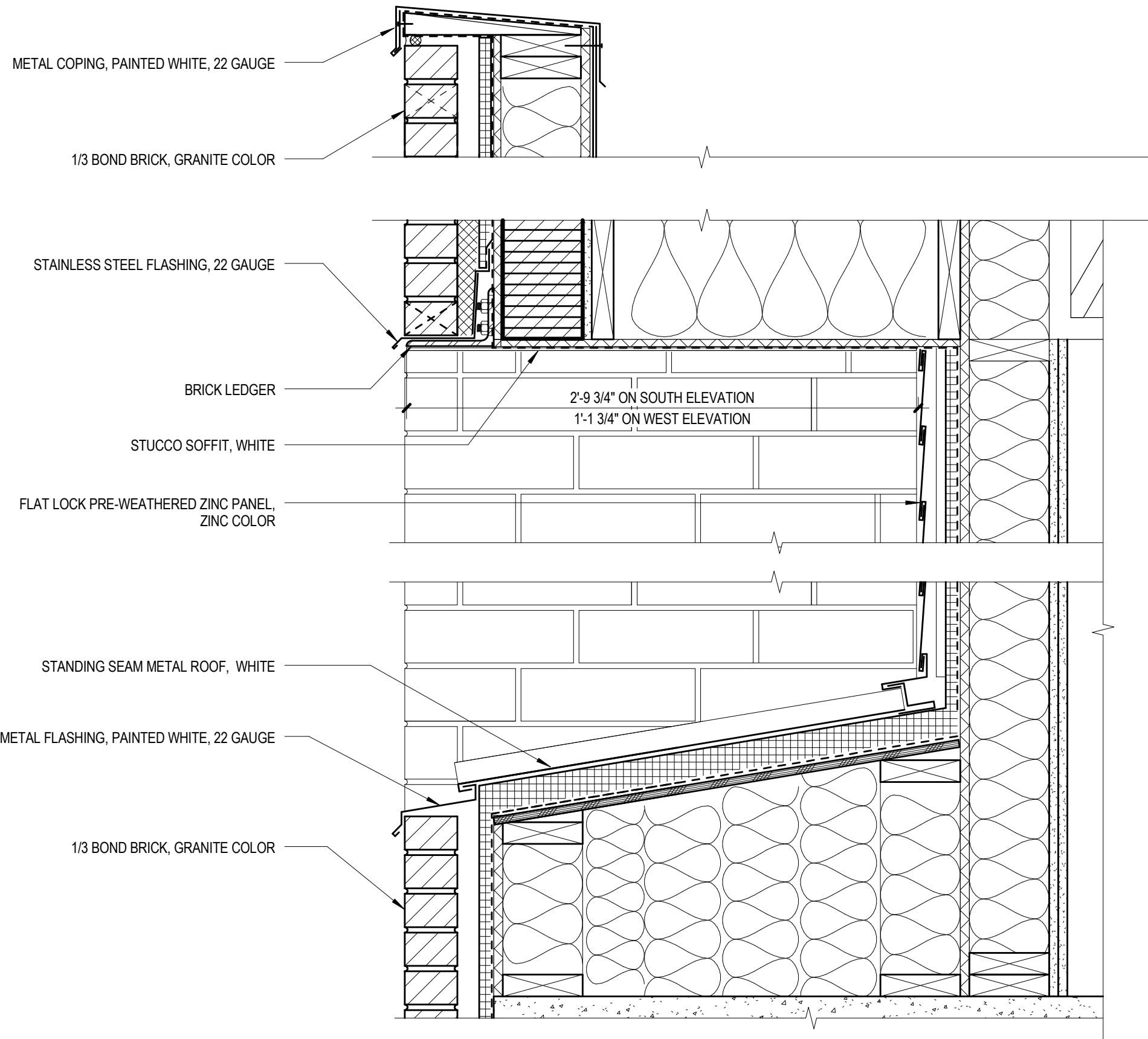

FLAT LOCK PANEL RECESS

1 1/2" = 1'-0"

1

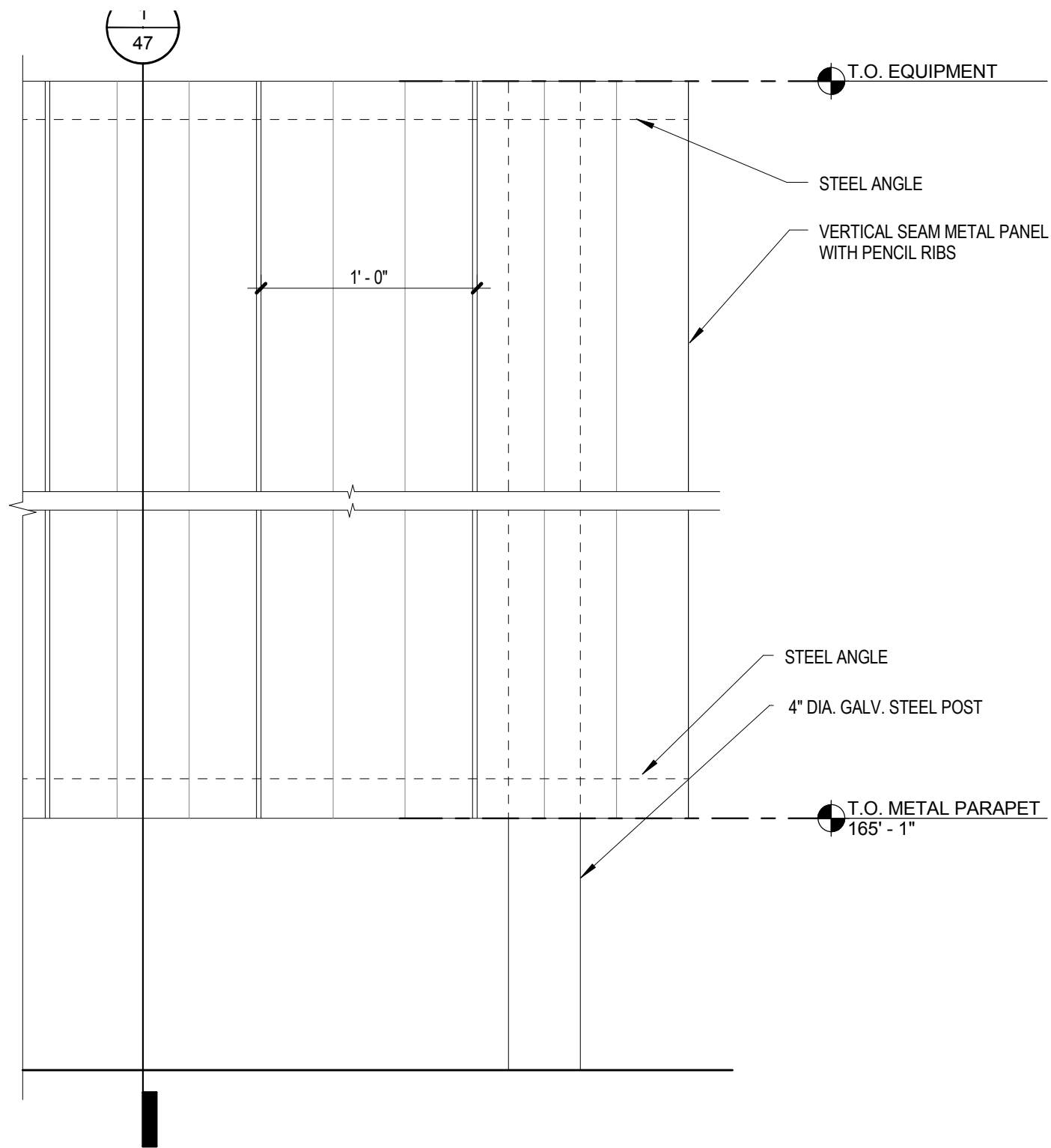

ROOF SCREEN ELEVATION

1 1/2" = 1'-0"

2

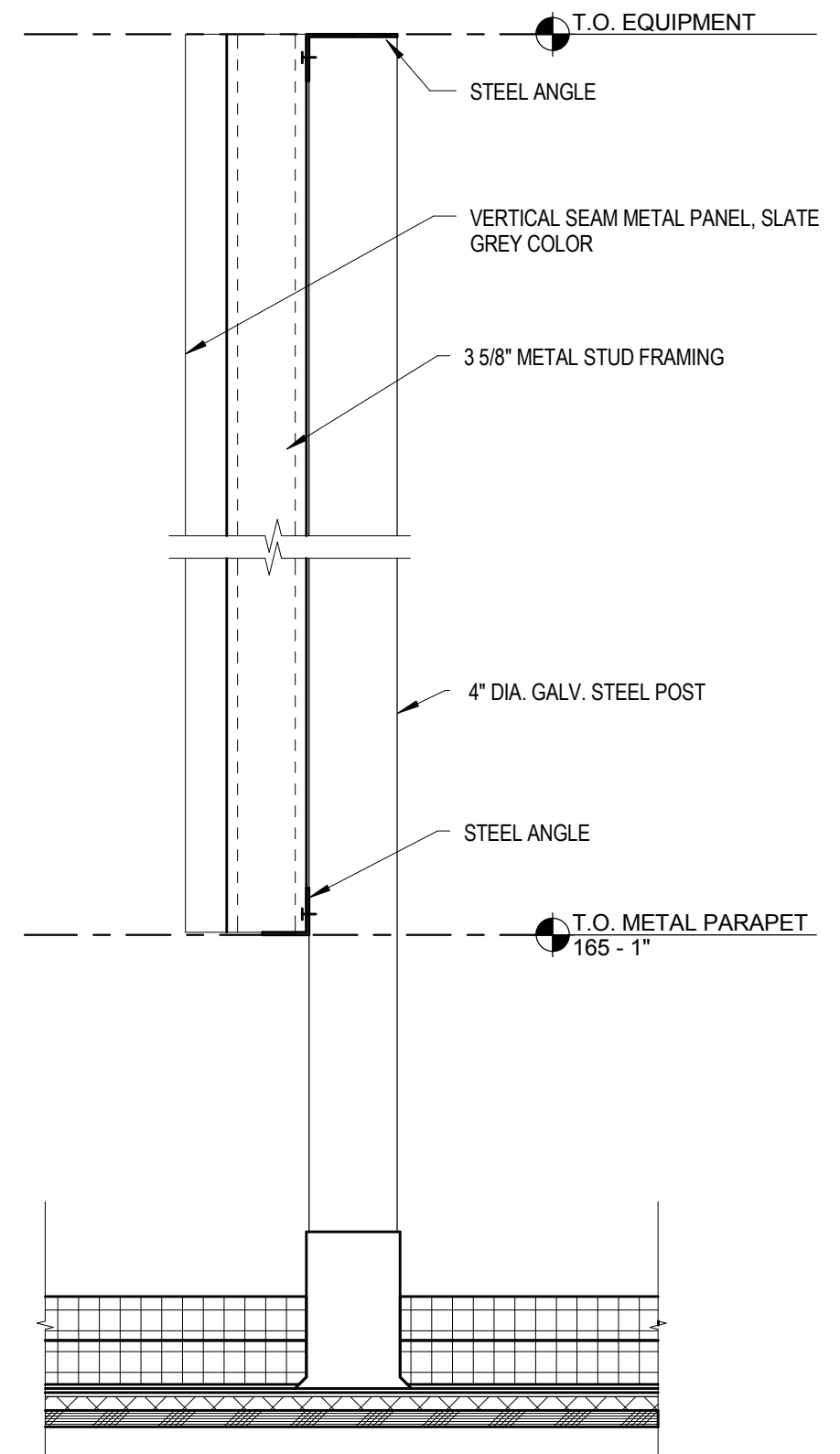

SECTION @ ROOF SCREEN

1 1/2" = 1'-0"

1

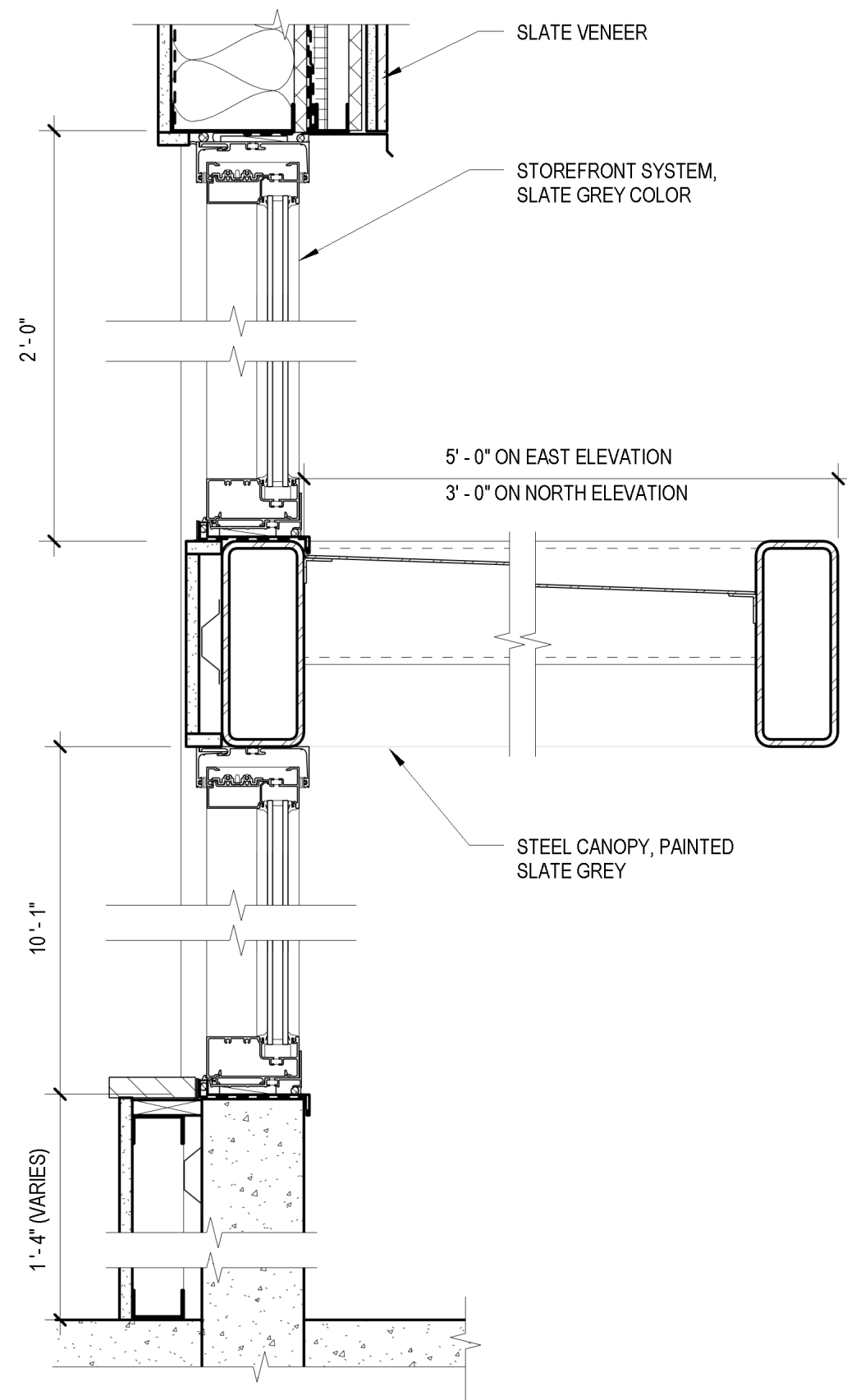

CANOPY @ RETAIL

1 1/2" = 1'-0"

2

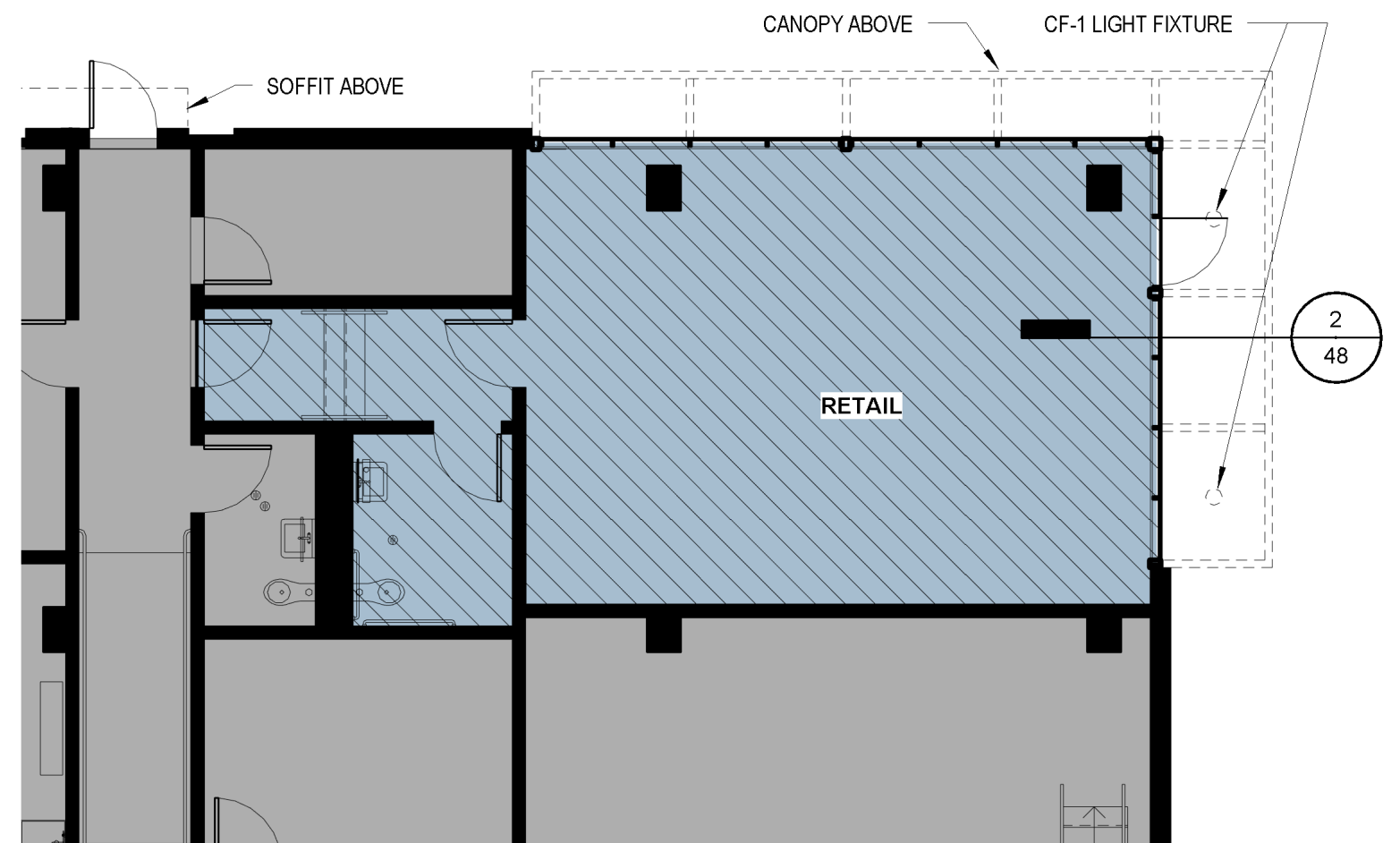

RETAIL AREA 763 SF*
*147 SF SUPPORT AREA

LEVEL 1 RETAIL

1/8" = 1'-0"



1



KEYNOTES - EXTERIOR ELEVATIONS

- 1 NORMAN SIZE BRICK, 1/3 RUNNING BOND
- 2 FLAT LOCK METAL PANEL SYSTEM
- 3 SLATE VENEER
- 4 STOREFRONT GLAZING SYSTEM
- 5 WINDOW WALL GLAZING SYSTEM
- 6 PAINTED ALUMINUM TUBE AND METAL PANEL CANOPY
- 7 STUCCO REVEAL
- 8 CONCRETE CURB
- 9 SUNSHADE
- 10 VERTICAL SEAM METAL PANEL MECHANICAL SCREENING
- 11 ALL GLASS ENTRY DOOR, AUTOMATIC SWING
- 12 VEGETATED SCREEN WALL, SEE LANDSCAPE
- 13 PARKING GARAGE GLAZED RIGID ROLLING DOOR
- 14 SCUPPER AND DOWNSPOUT
- 15 LOUVER
- 16 HOSE BIB
- 17 PLANTER WALL
- 18 STEEL CABLE/ALUMINUM GUARDRAIL
- 19 CONTROL JOINT
- 20 GENERATOR REMOTE FUEL FILL PORT
- 21 GAS METER

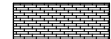
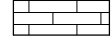
LEGEND - EXTERIOR ELEVATIONS

-  FLAT LOCK METAL PANEL
-  BRICK
-  SLATE VENEER
-  CONCRETE

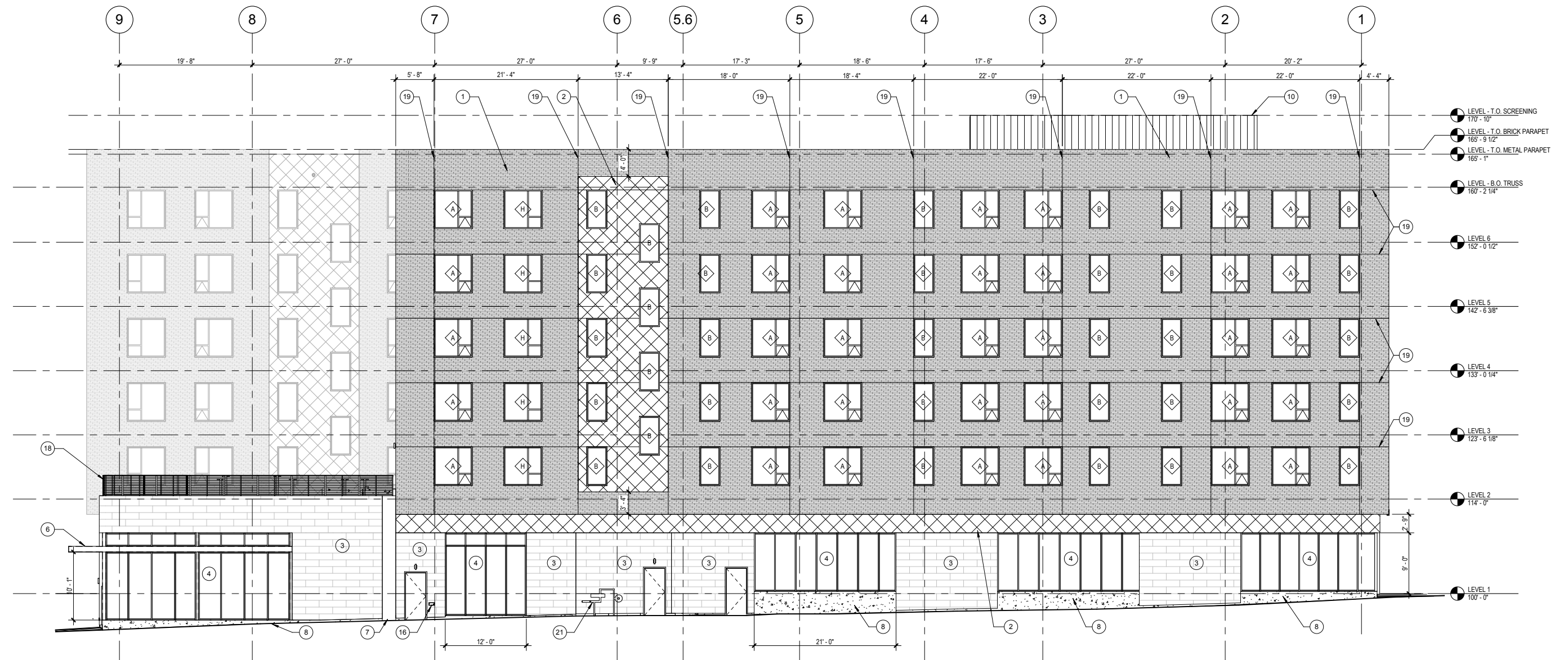





NORTH ELEVATION 2
1/8" = 1'-0"

KEYNOTES - EXTERIOR ELEVATIONS

- 1 NORMAN SIZE BRICK, 1/3 RUNNING BOND
- 2 FLAT LOCK METAL PANEL SYSTEM
- 3 SLATE VENEER
- 4 STOREFRONT GLAZING SYSTEM
- 5 WINDOW WALL GLAZING SYSTEM
- 6 PAINTED ALUMINUM TUBE AND METAL PANEL CANOPY
- 7 STUCCO REVEAL
- 8 CONCRETE CURB
- 9 SUNSHADE
- 10 VERTICAL SEAM METAL PANEL MECHANICAL SCREENING
- 11 ALL GLASS ENTRY DOOR, AUTOMATIC SWING
- 12 VEGETATED SCREEN WALL, SEE LANDSCAPE
- 13 PARKING GARAGE GLAZED RIGID ROLLING DOOR
- 14 SCUPPER AND DOWNSPOUT
- 15 LOUVER
- 16 HOSE BIB
- 17 PLANTER WALL
- 18 STEEL CABLE/ALUMINUM GUARDRAIL
- 19 CONTROL JOINT
- 20 GENERATOR REMOTE FUEL FILL PORT
- 21 GAS METER

LEGEND - EXTERIOR ELEVATIONS

-  FLAT LOCK METAL PANEL
-  BRICK
-  SLATE VENEER
-  CONCRETE

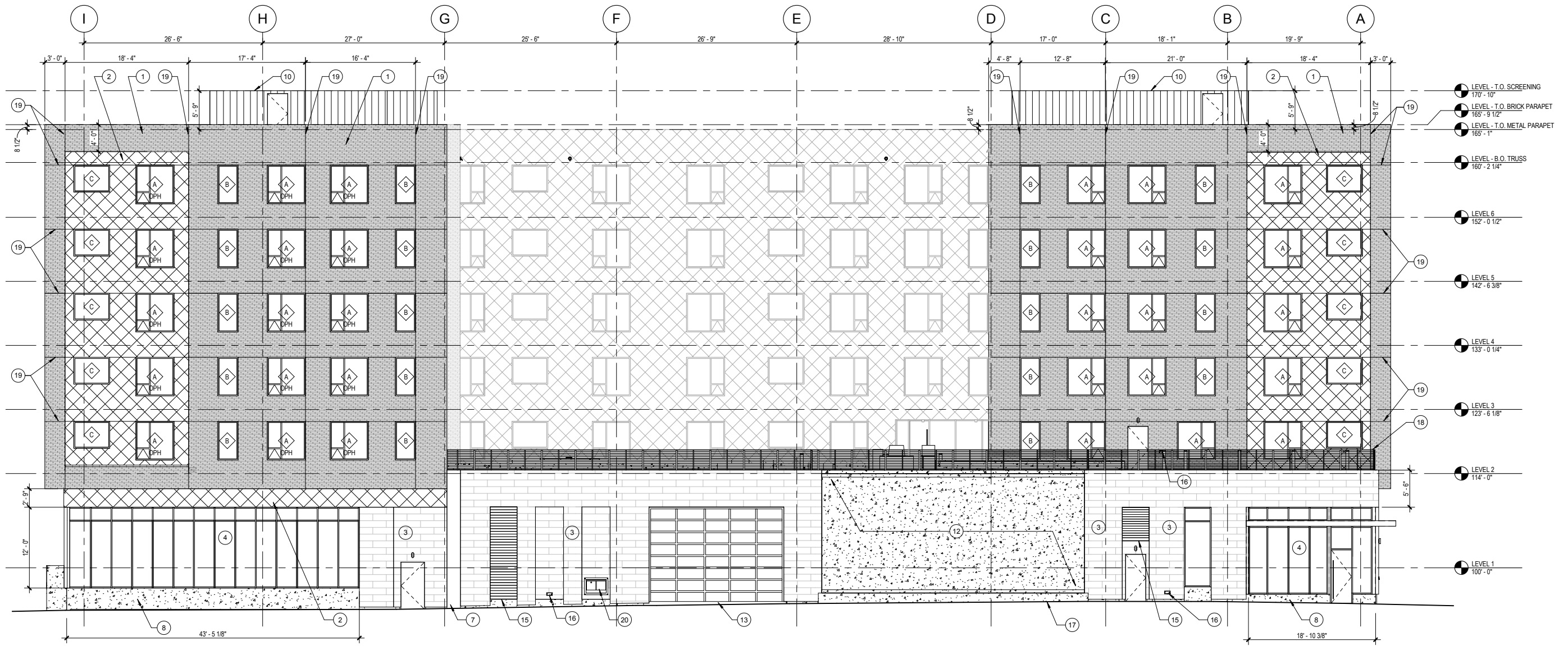





EAST ELEVATION 1
1/8" = 1'-0"

KEYNOTES - EXTERIOR ELEVATIONS

- 1 NORMAN SIZE BRICK, 1/3 RUNNING BOND
- 2 FLAT LOCK METAL PANEL SYSTEM
- 3 SLATE VENEER
- 4 STOREFRONT GLAZING SYSTEM
- 5 WINDOW WALL GLAZING SYSTEM
- 6 PAINTED ALUMINUM TUBE AND METAL PANEL CANOPY
- 7 STUCCO REVEAL
- 8 CONCRETE CURB
- 9 SUNSHADE
- 10 VERTICAL SEAM METAL PANEL MECHANICAL SCREENING
- 11 ALL GLASS ENTRY DOOR, AUTOMATIC SWING
- 12 VEGETATED SCREEN WALL, SEE LANDSCAPE
- 13 PARKING GARAGE GLAZED RIGID ROLLING DOOR
- 14 SCUPPER AND DOWNSPOUT
- 15 LOUVER
- 16 HOSE BIB
- 17 PLANTER WALL
- 18 STEEL CABLE/ALUMINUM GUARDRAIL
- 19 CONTROL JOINT
- 20 GENERATOR REMOTE FUEL FILL PORT
- 21 GAS METER

LEGEND - EXTERIOR ELEVATIONS

-  FLAT LOCK METAL PANEL
-  BRICK
-  SLATE VENEER
-  CONCRETE

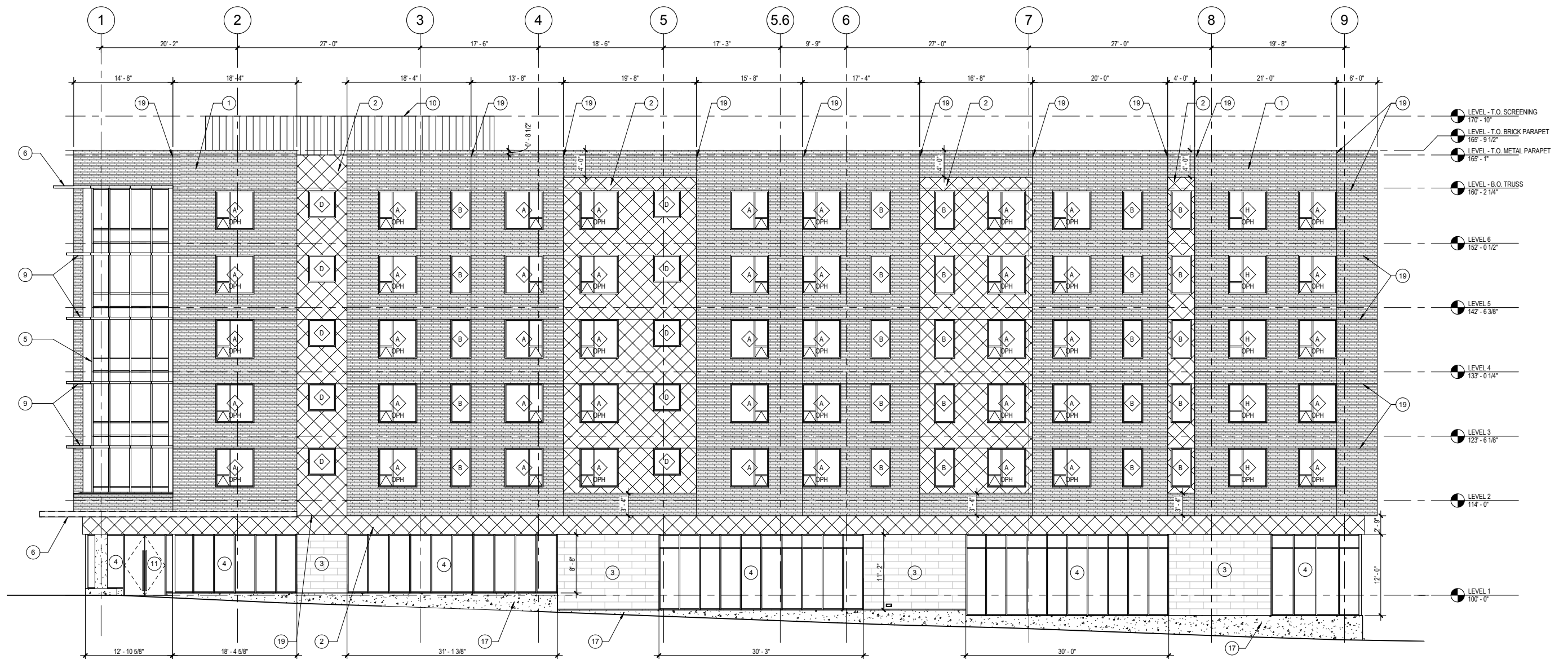



SOUTH ELEVATION 2
1/8" = 1'-0"

KEYNOTES - EXTERIOR ELEVATIONS

- 1 NORMAN SIZE BRICK, 1/3 RUNNING BOND
- 2 FLAT LOCK METAL PANEL SYSTEM
- 3 SLATE VENEER
- 4 STOREFRONT GLAZING SYSTEM
- 5 WINDOW WALL GLAZING SYSTEM
- 6 PAINTED ALUMINUM TUBE AND METAL PANEL CANOPY
- 7 STUCCO REVEAL
- 8 CONCRETE CURB
- 9 SUNSHADE
- 10 VERTICAL SEAM METAL PANEL MECHANICAL SCREENING
- 11 ALL GLASS ENTRY DOOR, AUTOMATIC SWING
- 12 VEGETATED SCREEN WALL, SEE LANDSCAPE
- 13 PARKING GARAGE GLAZED RIGID ROLLING DOOR
- 14 SCUPPER AND DOWNSPOUT
- 15 LOUVER
- 16 HOSE BIB
- 17 PLANTER WALL
- 18 STEEL CABLE/ALUMINUM GUARDRAIL
- 19 CONTROL JOINT
- 20 GENERATOR REMOTE FUEL FILL PORT
- 21 GAS METER

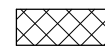
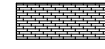
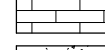
LEGEND - EXTERIOR ELEVATIONS

-  FLAT LOCK METAL PANEL
-  BRICK
-  SLATE VENEER
-  CONCRETE

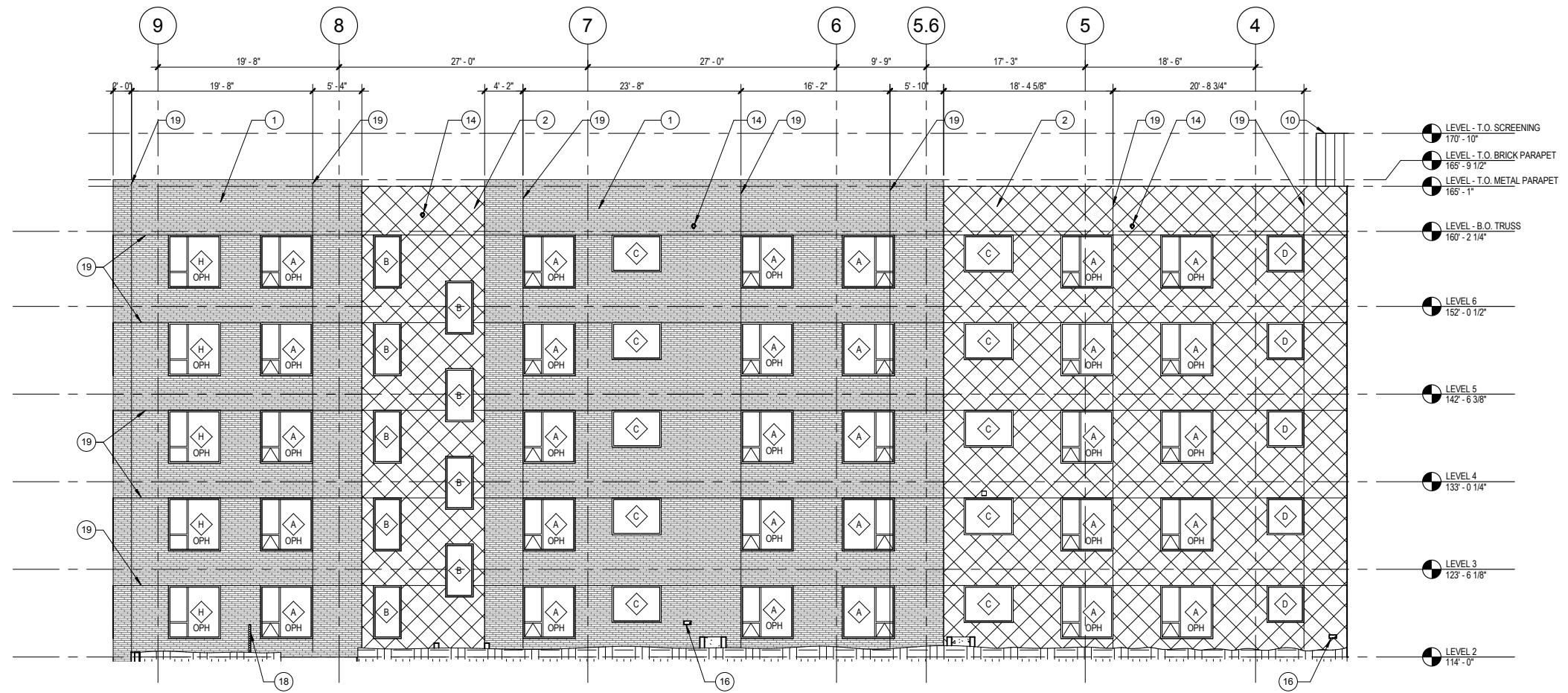





NORTH COURTYARD ELEVATION 1
1/8" = 1'-0"

KEYNOTES - EXTERIOR ELEVATIONS

- 1 NORMAN SIZE BRICK, 1/3 RUNNING BOND
- 2 FLAT LOCK METAL PANEL SYSTEM
- 3 SLATE VENEER
- 4 STOREFRONT GLAZING SYSTEM
- 5 WINDOW WALL GLAZING SYSTEM
- 6 PAINTED ALUMINUM TUBE AND METAL PANEL CANOPY
- 7 STUCCO REVEAL
- 8 CONCRETE CURB
- 9 SUNSHADE
- 10 VERTICAL SEAM METAL PANEL MECHANICAL SCREENING
- 11 ALL GLASS ENTRY DOOR, AUTOMATIC SWING
- 12 VEGETATED SCREEN WALL, SEE LANDSCAPE
- 13 PARKING GARAGE GLAZED RIGID ROLLING DOOR
- 14 SCUPPER AND DOWNSPOUT
- 15 LOUVER
- 16 HOSE BIB
- 17 PLANTER WALL
- 18 STEEL CABLE/ALUMINUM GUARDRAIL
- 19 CONTROL JOINT
- 20 GENERATOR REMOTE FUEL FILL PORT
- 21 GAS METER

LEGEND - EXTERIOR ELEVATIONS

-  FLAT LOCK METAL PANEL
-  BRICK
-  SLATE VENEER
-  CONCRETE

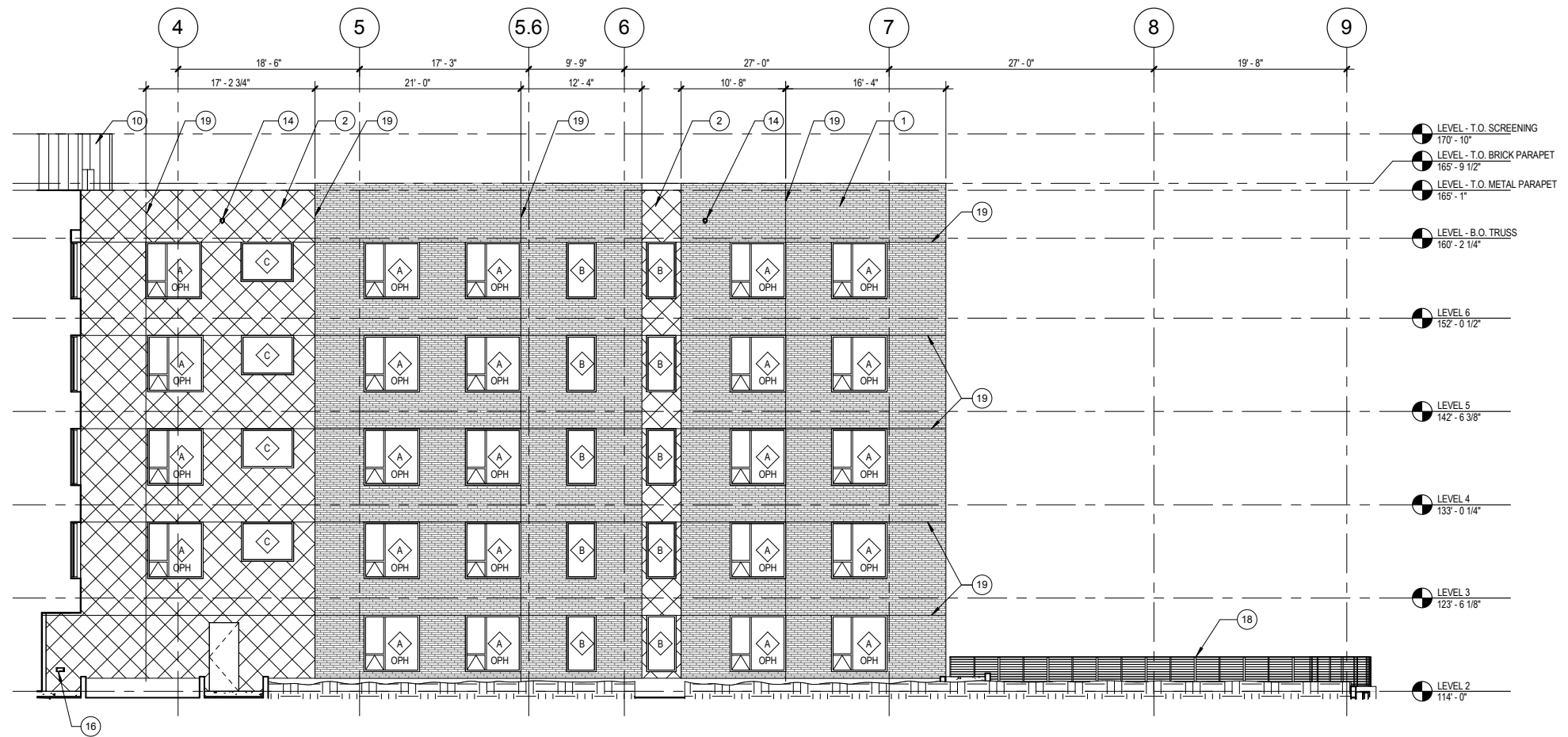





SOUTH COURTYARD ELEVATION 3
1/8" = 1'-0"

KEYNOTES - EXTERIOR ELEVATIONS

- 1 NORMAN SIZE BRICK, 1/3 RUNNING BOND
- 2 FLAT LOCK METAL PANEL SYSTEM
- 3 SLATE VENEER
- 4 STOREFRONT GLAZING SYSTEM
- 5 WINDOW WALL GLAZING SYSTEM
- 6 PAINTED ALUMINUM TUBE AND METAL PANEL CANOPY
- 7 STUCCO REVEAL
- 8 CONCRETE CURB
- 9 SUNSHADE
- 10 VERTICAL SEAM METAL PANEL MECHANICAL SCREENING
- 11 ALL GLASS ENTRY DOOR, AUTOMATIC SWING
- 12 VEGETATED SCREEN WALL, SEE LANDSCAPE
- 13 PARKING GARAGE GLAZED RIGID ROLLING DOOR
- 14 SCUPPER AND DOWNSPOUT
- 15 LOUVER
- 16 HOSE BIB
- 17 PLANTER WALL
- 18 STEEL CABLE/ALUMINUM GUARDRAIL
- 19 CONTROL JOINT
- 20 GENERATOR REMOTE FUEL FILL PORT
- 21 GAS METER

LEGEND - EXTERIOR ELEVATIONS





-  FLAT LOCK METAL PANEL
-  BRICK
-  SLATE VENEER
-  CONCRETE



KEYNOTES - EXTERIOR ELEVATIONS

- 1 NORMAN SIZE BRICK, 1/3 RUNNING BOND
- 2 FLAT LOCK METAL PANEL SYSTEM
- 3 SLATE VENEER
- 4 STOREFRONT GLAZING SYSTEM
- 5 WINDOW WALL GLAZING SYSTEM
- 6 PAINTED ALUMINUM TUBE AND METAL PANEL CANOPY
- 7 STUCCO REVEAL
- 8 CONCRETE CURB
- 9 SUNSHADE
- 10 VERTICAL SEAM METAL PANEL MECHANICAL SCREENING
- 11 ALL GLASS ENTRY DOOR, AUTOMATIC SWING
- 12 VEGETATED SCREEN WALL, SEE LANDSCAPE
- 13 PARKING GARAGE GLAZED RIGID ROLLING DOOR
- 14 SCUPPER AND DOWNSPOUT
- 15 LOUVER
- 16 HOSE BIB
- 17 PLANTER WALL
- 18 STEEL CABLE/ALUMINUM GUARDRAIL
- 19 CONTROL JOINT
- 20 GENERATOR REMOTE FUEL FILL PORT
- 21 GAS METER

LEGEND - EXTERIOR ELEVATIONS

-  FLAT LOCK METAL PANEL
-  BRICK
-  SLATE VENEER
-  CONCRETE