



CITY OF
PORTLAND, OREGON
 BUREAU OF DEVELOPMENT SERVICES
 1900 SW 4th Ave., Suite 5000
 Portland, OR 97201



FACILITY PERMIT

14-185397-000-00-FA

Site Address: 5840 NE HASSALO ST

Issued: 7/17/14

SP-Fire Sprinklers:3490877 3490877:BIP-070:Banfield PK

PROJECT INFORMATION		Occ. Group	Const. Type
Fire Sprinklers	Alteration		
Project Description: extension of fire sprinkler system to protect future manufacturing warehouse and office--- 2 sets of plans			

APPLICANT	WYATT FIRE PROTECTION INC	Phone (503) 684-2928
PROPERTY OWNER	PACIFIC REALTY ASSOCIATES	Phone
CONTRACTOR	No Contractor	Phone

Project Details		Project Details	
Building/Mechanical Inspector	BURRISS	Code Edition (Year)	2010 OSSC
Electrical Inspector	HARTFIEL	Energy Code Edition	2010 Oregon Energy
Fire Marshal	RANDALLJ	Folder Name	Fire Sprinklers
Plumbing Inspector	SISKJ	Project Reference Number	FPPCONV
Zoning - Property (1)	R5(R1),R5(RH),EG2		

Permit Final 08/14/14

FOR INSPECTION CONTACT Randall, Jerry at 503-823-3802

Jerry Randall
 Fire & Life Plans Examiner
 1900 SW 4th Ave.
 Portland, Or 97201
 Ph: (503) 823-3802 Fax: (503) 823-7425

This permit expires if, at any time, 180 days pass without an approved inspection. If you are not able to obtain an inspection approval within 180 days, you may request a one-time only extension of 180 days by calling 503-823-5996.

BEFORE YOU DIG

ATTENTION: Oregon law requires you to follow rules adopted by the Oregon Utility Notification Center. Those rules are set forth in OAR 952-001-0010 through OAR 952-001-0090. You may obtain copies of the rules by calling the center. (Note: the telephone number for the Oregon Utility Notification Center is 1-800-332-2344).

CITY CONTACT

E-Mail:

Phone:

Fax: (503) 823-7425

INSPECTION REQUEST PHONE NUMBERS

TDD: (503) 823-6868

IVR Inspection Request Number:

Contact your inspector directly for inspection requests.



18



**Portland Fire & Rescue
Facilities Permit
Application for Permit to Install Sprinkler System
1900 SW 4th Avenue, Portland, OR 97201
Phone: 503.823.3712**

VALUATION OF WORK: \$ 12,750

DATE: 7/10/14

**PLANS MUST BE SUBMITTED TO THE FIRE PREVENTION DIVISION
AND APPROVED BEFORE INSTALLATION.**

Location:

Building Name: Banfield Industrial Park D Occupied as: _____

Address: 5600 NE Hassalo St Portland, OR Zip 97213

Suite # Building D Levels (#) _____ 00-176709 FC

Installation	Sprinkler	Sprinkler Type	Supply	Standpipe
Addition <input checked="" type="checkbox"/>	Complete <input checked="" type="checkbox"/>	Wet <input checked="" type="checkbox"/>	Underground Only <input type="checkbox"/>	Wet <input type="checkbox"/>
Alteration <input checked="" type="checkbox"/>	Partial <input type="checkbox"/>	Dry <input type="checkbox"/>	Sprinkler Only <input checked="" type="checkbox"/>	Dry <input type="checkbox"/>
New <input type="checkbox"/>	Basement <input type="checkbox"/>	Preaction <input type="checkbox"/>	Underground with Hydrants <input type="checkbox"/>	Combination <input type="checkbox"/>
Remove <input type="checkbox"/>	Exit way <input type="checkbox"/>	Deluge <input type="checkbox"/>	Sprinkler with Hydrants <input type="checkbox"/>	
Repair <input type="checkbox"/>	Hood/Vent <input type="checkbox"/>	Anti-freeze <input type="checkbox"/>		
	Spray Booth <input type="checkbox"/>			

Light Hazard Ordinary Hazard 1 2 Extra Hazard 1 2 ESRF ELO High Piled Storage

Total Work Area _____ sq ft Total No. of Heads 132 Sprinkler Area 100 sq ft
 Building Size 56405 sq ft No. of Standpipes _____ Orifice Size 1/2 3/4 inches
 No. of Stories 1 Density 0.3 gpm/sq ft "K" Factor 5.6/8.0
 No. of Systems _____ Design Area 2000 sq ft Temp. Rating 155/286 F

Description of Work: Extension of fine sprinkler system to protect future manufacturing/warehouse and office

Installing Company Information:

Applicant Name: Ashley Payne
 Company Name: Wyatt Fire Protection
 Address: 9095 SW Burnham St
 City, State, Zip: Tigard, OR 97223
 Phone/Fax: 503-684-2928

Owner Information:

Name: PacTrust
 Phone/Fax: _____
 Mail permit to: Ashley Payne
 Address: _____
 City, State, Zip: _____

Ashley Payne
 NAME OF APPLICANT
Jerry Randall
 NAME OF INSPECTOR

Ashley Payne
 SIGNATURE
Jerry Randall
 SIGNATURE

7/10/14
 DATE
7/17/14
 DATE

14-185397 FA

Facilities Permit

Sprinkler/Underground Permit Submittal Requirements

Scope: Fire permits for work associated with a Facility Permit Project. Fees will be billed monthly.

1. Permit Application, including related facilities project permit number.
2. Two sets of plans. Plans need to be of a quality clear enough to microfilm. Name of project, job address, and the engineers/architect's name designing the system must be on all sheets.
3. Specification sheets of all equipment in the system.
4. Hydraulically-designed fire sprinkler systems –
 - Portland Water Bureau flow test sheets. All systems must be designed using 80% of the normal maximum static pressure.
 - Hydraulic calculations necessary to verify design details.
5. Underground systems –
 - All necessary features relating to the scope of the permit application, including fire department connection, back flow prevention, thrust restraints, etc.
6. Any relevant appeal information.

Note: To install sprinkler systems and underground sprinkler water supply piping, the installer is required to have

a Certificate of Fitness issued by Portland Fire & Rescue.

For questions, please call 503-823-3712.

Submit plans to: Facilities Program
Bureau of Development Services
1900 SW 4th Ave – 5th Floor
Portland, OR 97201

HYDRAULIC CALCULATIONS
for

Job Information

Project Name : *BANFIELD IND. PARK BLDG. D*
Contract No. : _____ City: *PORTLAND*
Project Location: *5600 NE HASSALO* Date: 5/5/2014

Contractor Information

Name of Contractor: *WYATT FIRE PROTECTION*
Address: *9095 SW - BURNHAM* City: *TILGARD*
Phone Number: *503 684-2928* E-mail: _____
Name of Designer: *BRUCE PEARSON*
Authority Having Jurisdiction: *CITY OF PORTLAND FMD*

Design

Remote Area Name	DesignArea_1
Remote Area Location	
Occupancy Classification	
Density (gpm/ft ²)	0.3
Area of Application (ft ²)	2000
Coverage per Sprinkler (ft ²)	100
Number of Calculated Sprinklers	20
In-Rack Demand (gpm)	0
Special Heads	
Hose Streams (gpm)	1000
Total Water Required (incl. Hose Streams) (gpm)	1616.8
Required Pressure at Source (psi)	53.4
Type of System	Wet
Volume - Entire System (gal)	1625.5 gal

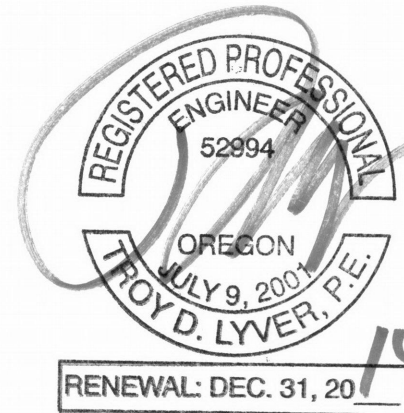

14-185397 FA

Water Supply Information

Date: 4/30/14
Location: 910 NE 57th Avenue
Source: Portland Public Water

Notes

Diagram for Design Area : DesignArea_1

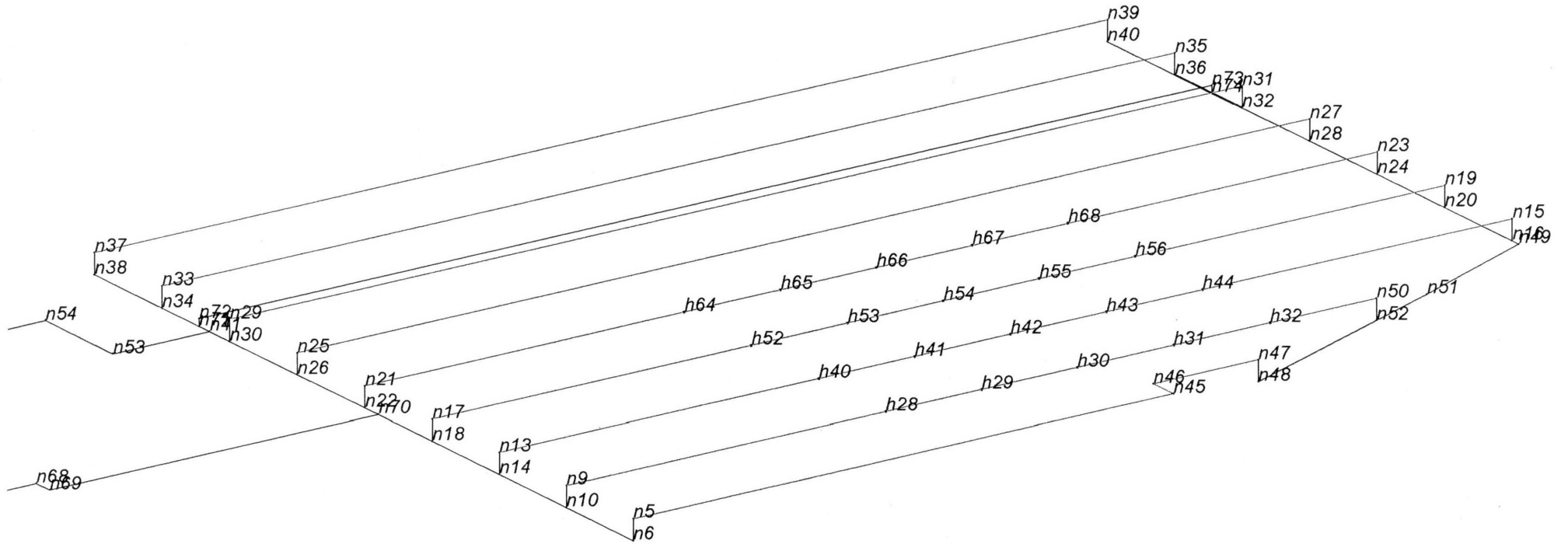

ob :

Node Labels: Node Reference
Pipe Labels: Off

Diagram for Design Area : DesignArea_1

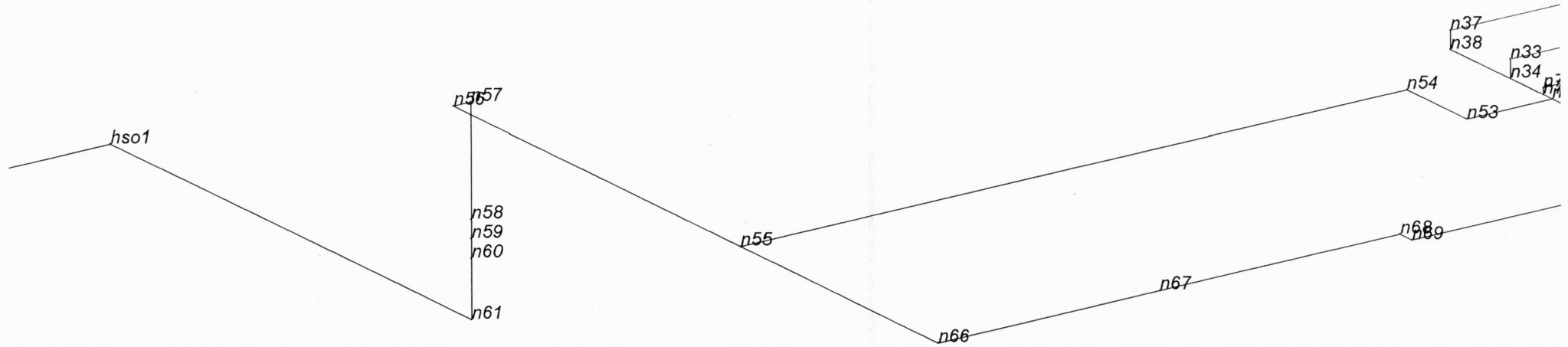

ob :

Node Labels: Node Reference
Pipe Labels: Off

Diagram for Design Area : DesignArea_1

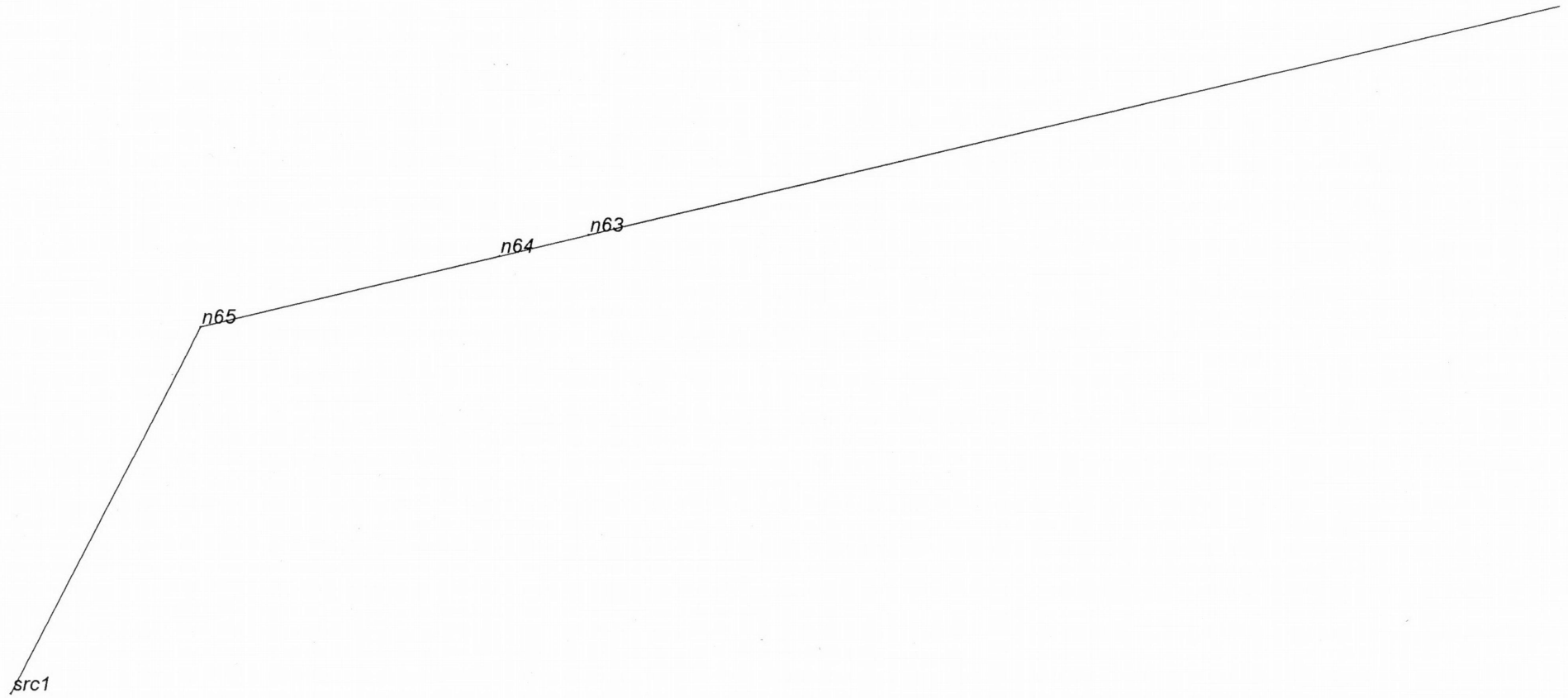

Job :

Hydraulic Analysis for : DesignArea_1

Calculation Info

Calculation Mode	Demand
Hydraulic Model	Hazen-Williams
Fluid Name	Water @ 60F (15.6C)
Fluid Weight, (lb/ft ³)	N/A for Hazen-Williams calculation.
Fluid Dynamic Viscosity, (lb·s/ft ²)	N/A for Hazen-Williams calculation.

Water Supply Parameters

Supply 1 : src1

Flow (gpm)	Pressure (psi)
0	71
2500	49

Hoses

Inside Hose Flow / Standpipe Demand (gpm)	0
Outside Hose Flow (gpm)	500
Additional Outside Hose Flow (gpm)	500
Other (custom defined) Hose Flow (gpm)	0

Total Hose Flow (gpm)	1000

Sprinklers

Ovehead Sprinkler Flow (gpm)	616.8
InRack Sprinkler Flow (gpm)	0
Other (custom defined) Sprinkler Flow (gpm)	0

Total Sprinkler Flow (gpm)	616.8

Other

Required Margin of Safety (psi)	0
Base of Riser - Pressure (psi)	53.4
Base of Riser - Flow (gpm)	1116.8
Demand w/o System Pump(s)	N/A

Hydraulic Analysis for : DesignArea_1

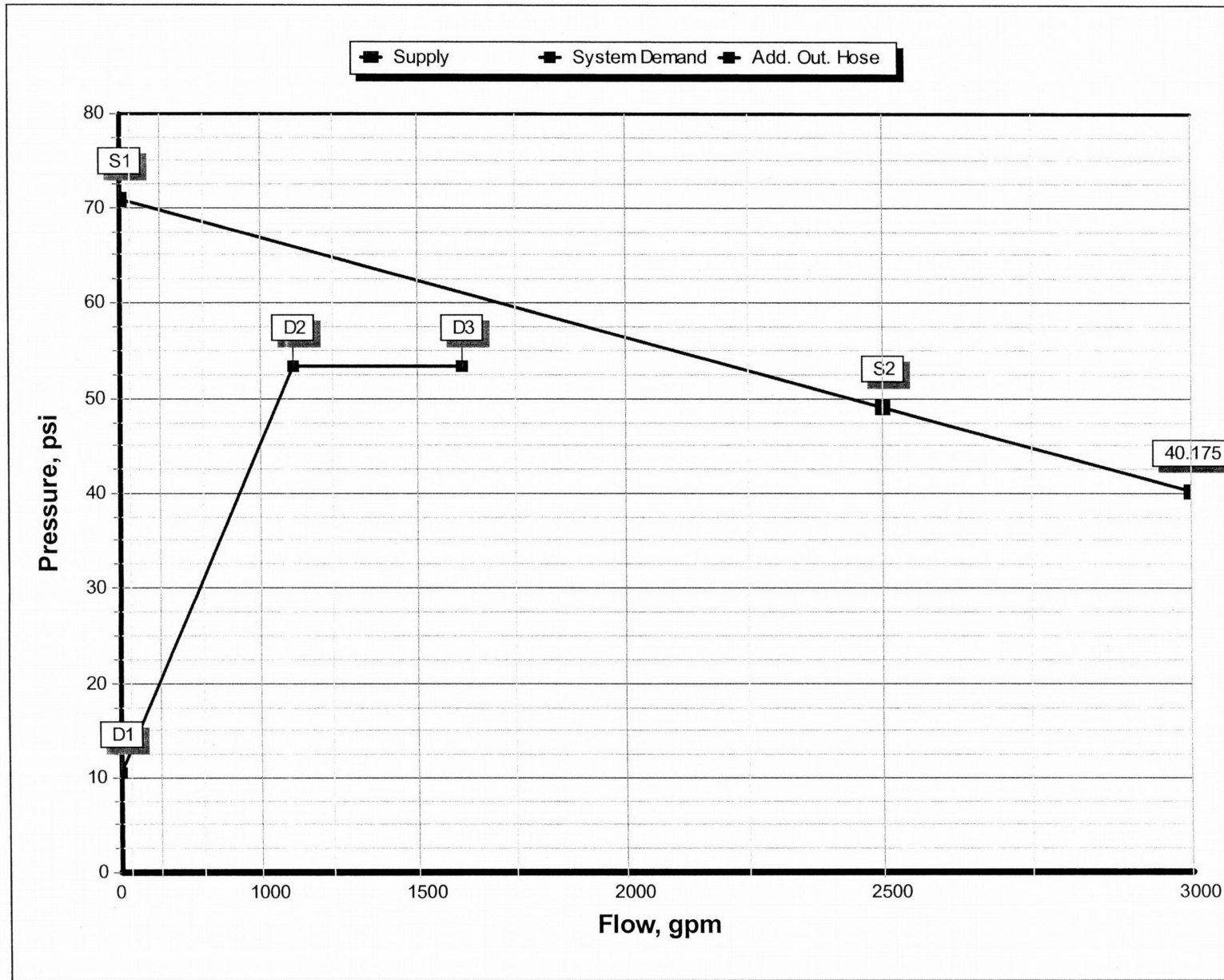

Job :

Hydraulic Analysis for : DesignArea_1

Graph Labels

Label	Description	Values	
		Flow (gpm)	Pressure (psi)
S1	Supply point #1 - Static	0	71
S2	Supply point #2 - Residual	2500	49
D1	Elevation Pressure	0	10.5
D2	System Demand	1116.8	53.4
D3	System Demand + Add.Out.Hose	1616.8	53.4

Curve Intersections & Safety Margins

Curve Name	Intersection		Safety Margin	
	Pressure (psi)	Flow (gpm)	Pressure (psi)	@ Flow (gpm)
Supply	64.7	1267.6	7.8	1616.8

Open Heads

Head Ref.	Head Type	Coverage	K-Factor	Required			Calculated		
				Density	Flow	Pressure	Density	Flow	Pressure
		(ft ²)	(gpm/psi ^{1/2})	(gpm/ft ²)	(gpm)	(psi)	(gpm/ft ²)	(gpm)	(psi)
h28	Overhead Sprinkler	100	8	0.3	30	14.1	0.323	32.3	16.3
h29	Overhead Sprinkler	100	8	0.3	30	14.1	0.315	31.5	15.5
h30	Overhead Sprinkler	100	8	0.3	30	14.1	0.313	31.3	15.3
h31	Overhead Sprinkler	100	8	0.3	30	14.1	0.314	31.4	15.4
h32	Overhead Sprinkler	100	8	0.3	30	14.1	0.319	31.9	15.9
h40	Overhead Sprinkler	100	8	0.3	30	14.1	0.313	31.3	15.3
h41	Overhead Sprinkler	100	8	0.3	30	14.1	0.303	30.3	14.3
h42	Overhead Sprinkler	100	8	0.3	30	14.1	0.3	30	14.1
h43	Overhead Sprinkler	100	8	0.3	30	14.1	0.3	30	14.1
h44	Overhead Sprinkler	100	8	0.3	30	14.1	0.303	30.3	14.4
h52	Overhead Sprinkler	100	8	0.3	30	14.1	0.314	31.4	15.4
h53	Overhead Sprinkler	100	8	0.3	30	14.1	0.304	30.4	14.4
h54	Overhead Sprinkler	100	8	0.3	30	14.1	0.301	30.1	14.2

h55	Overhead Sprinkler	100	8	0.3	30	14.1	0.301	30.1	14.2
h56	Overhead Sprinkler	100	8	0.3	30	14.1	0.304	30.4	14.5
h64	Overhead Sprinkler	100	8	0.3	30	14.1	0.317	31.7	15.7
h65	Overhead Sprinkler	100	8	0.3	30	14.1	0.307	30.7	14.7
h66	Overhead Sprinkler	100	8	0.3	30	14.1	0.304	30.4	14.5
h67	Overhead Sprinkler	100	8	0.3	30	14.1	0.304	30.4	14.5
h68	Overhead Sprinkler	100	8	0.3	30	14.1	0.308	30.8	14.8

Node Data

Node#	Elev	Hgroup	Tot. Pres.	Discharge	K-Fact.	Req. Discharge	Req. Pres.
	ft		psi	gpm	gpm/psi ^{1/2}	gpm	psi
n5	21.25	NODE	25.4				
n6	19.25	NODE	26.9				
h28	21.25	HEAD	16.3	32.3	8	30	14.1
h29	21.25	HEAD	15.5	31.5	8	30	14.1
h30	21.25	HEAD	15.3	31.3	8	30	14.1
h31	21.25	HEAD	15.4	31.4	8	30	14.1
h32	21.25	HEAD	15.9	31.9	8	30	14.1
n9	21.25	NODE	23.8				
n10	19.25	NODE	26.9				
h40	21.25	HEAD	15.3	31.3	8	30	14.1
h41	21.25	HEAD	14.3	30.3	8	30	14.1
h42	21.25	HEAD	14.1	30	8	30	14.1
h43	21.25	HEAD	14.1	30	8	30	14.1
h44	21.25	HEAD	14.4	30.3	8	30	14.1
n13	21.25	NODE	23.6				
n14	19.25	NODE	27				
n15	21.25	NODE	18.7				
n16	19.25	NODE	20.8				
h52	21.25	HEAD	15.4	31.4	8	30	14.1
h53	21.25	HEAD	14.4	30.4	8	30	14.1
h54	21.25	HEAD	14.2	30.1	8	30	14.1
h55	21.25	HEAD	14.2	30.1	8	30	14.1
h56	21.25	HEAD	14.5	30.4	8	30	14.1
n17	21.25	NODE	23.7				
n18	19.25	NODE	27.1				
n19	21.25	NODE	18.9				
n20	19.25	NODE	21				
h64	21.25	HEAD	15.7	31.7	8	30	14.1
h65	21.25	HEAD	14.7	30.7	8	30	14.1
h66	21.25	HEAD	14.5	30.4	8	30	14.1
h67	21.25	HEAD	14.5	30.4	8	30	14.1
h68	21.25	HEAD	14.8	30.8	8	30	14.1
n21	21.25	NODE	23.9				
n22	19.25	NODE	27.3				
n23	21.25	NODE	19.4				
n24	19.25	NODE	21.6				
n25	21.25	NODE	26.1				
n26	19.25	NODE	27.4				
n27	21.25	NODE	22.6				
n28	19.25	NODE	22.8				
n29	21.25	NODE	26.3				
n30	19.25	NODE	27.5				
n31	21.25	NODE	23.4				
n32	19.25	NODE	23.6				

Node Data

Node#	Elev	Hgroup	Tot. Pres.	Discharge	K-Fact.	Req. Discharge	Req. Pres.
	ft		psi	gpm	gpm/psi ^{1/2}	gpm	psi
n33	21.25	NODE	26.6				
n34	19.25	NODE	27.8				
n35	21.25	NODE	23.7				
n36	19.25	NODE	24				
n37	21.25	NODE	26.7				
n38	19.25	NODE	27.8				
n39	21.25	NODE	23.5				
n40	19.25	NODE	24				
n41	19.25	NODE	27.9				
n53	19.25	NODE	28.8				
n45	21.25	NODE	21.8				
n46	21.25	NODE	21.3				
n47	21.25	NODE	20.4				
n48	19.25	NODE	20.8				
n49	19.25	NODE	20.8				
n50	21.25	NODE	18.1				
n51	19.25	NODE	20.7				
n52	19.25	NODE	20.6				
n54	19.25	NODE	29.6				
n55	19.25	NODE	33.3				
n56	19.25	NODE	35.5				
n57	19.25	NODE	36.7				
n58	7.25	NODE	42.1				
n59	5.25	NODE	43.3				
n60	3.25	NODE	44.2				
n61	-3	NODE	47.1				
hso1	-3	HOSE	47.6	500		500	
n63	-3	NODE	49.6				
n64	-3	NODE	53.1				
n65	-3	NODE	53.2				
src1	-3	SUPPLY	53.4	-1116.8			
n66	19.25	NODE	33.2				
n67	19.25	NODE	32.2				
n68	19.25	NODE	30.5				
n69	19.25	NODE	30				
n70	19.25	NODE	27.3				
n71	19.25	NODE	27.8				
n72	19.96	NODE	27				
n73	19.96	NODE	24.2				
n74	19.25	NODE	23.9				

PIPE INFORMATION

Node 1 Node 2	Elev 1 Elev 2	K-Factor 1 K-Factor 2	Flow added(q)* Total flow (Q)	Nominal ID Actual ID	Fittings quantity x (name) = length	L F T	C Factor Pf per ft	total (Pt) elev (Pe) frict (Pf)	NOTES
	(ft)	(gpm/psi ^{1/2})	(gpm)	(in)	(ft)	(ft)	(psi)	(psi)	
h42 h41	21.25 21.25	8 8	30 29.3	1.5 1.68		10 0 10	120 0.0265	14.1 0 0.3	
h41 h40	21.25 21.25	8 8	30.3 59.6	1.5 1.68		10 0 10	120 0.0987	14.3 0 1	
h40 n13	21.25 21.25	8	31.3 90.9	1.5 1.68	1x(us.90)=4.92	33.25 4.92 38.17	120 0.2159	15.3 0 8.2	
n13 n14	21.25 19.25		0 90.9	1.5 1.68	1x(us.Tee-Br)=9.84	2 9.84 11.84	120 0.2159	23.6 0.9 2.6	
n14 n18	19.25 19.25		131.1 221.9	4 4.26		10 0 10	120 0.0121	27 0 0.1	
n18 n70	19.25 19.25		90.9 312.8	4 4.26		8 0 8	120 0.0229	27.1 0 0.2	
n70 n69	19.25 19.25		-94.9 217.9	3 3.26	1x(us.90)=9.41 1x(us.Tee-Br)=20.16	34 29.57 63.57	120 0.0432	27.3 0 2.7	
n69 n68	19.25 19.25		0 217.9	3 3.26	1x(us.90)=9.41	2 9.41 11.41	120 0.0432	30 0 0.5	
n68 n67	19.25 19.25		0 217.9	3 3.068	1x(coupling)=1	28 1 29	120 0.0581	30.5 0 1.7	
n67 n66	19.25 19.25		0 217.9	3.5 3.548	1x(us.90)=8	26 8 34	120 0.0286	32.2 0 1	
n66 n55	19.25 19.25		0 217.9	5 5.047		33 0 33	120 0.0051	33.2 0 0.2	
n55 n56	19.25 19.25		398.9 616.8	5 5.047	1x(us.90)=12	48 12 60	120 0.0353	33.3 0 2.1	
n56 n57	19.25 19.25		0 616.8	4 4.026	1x(us.90)=10	2 10 12	120 0.1062	35.5 0 1.3	
n57 n58	19.25 7.25		0 616.8	6 6.065	1x(coupling)=1	12 1 13	120 0.0144	36.7 5.2 0.2	
n58 n59	7.25 5.25		0 616.8	6 0		2 0 2	0 0.1551	42.1 0.9 0.3	AV-1 Check
n59 n60	5.25 3.25		0 616.8	6 0		2 0 2	0 0.0063	43.3 0.9 0.0	Gate A2360
n60 n61	3.25 -3		0 616.8	6 6.4	1x(us.90)=24.19	6.25 24.19 30.44	140 0.0084	44.2 2.7 0.3	
n61 hso1	-3 -3		0 616.8	6 6.4		60 0 60	140 0.0084	47.1 0 0.5	

PIPE INFORMATION

Node 1 Node 2	Elev 1 Elev 2	K-Factor 1 K-Factor 2	Flow added (q)* Total flow (Q)	Nominal ID Actual ID	Fittings quantity x (name) = length	L F T	C Factor Pf per ft	total (Pt) elev (Pe) frict (Pf)	NOTES
	(ft)	(gpm/psi ^{1/2})	(gpm)	(in)	(ft)	(ft)	(psi)	(psi)	
hso1 n63	-3 -3		500 1116.8	8 8.55	1x(coupling)=3.52	320 3.52 323.52	140 0.0061	47.6 0 2	
n63 n64	-3 -3		0 1116.8	8 0		3 0 3	0 1.1456	49.6 0 3.4	Ames2000SS
n64 n65	-3 -3		0 1116.8	8 8.55	1x(us.45)=15.85	10 15.85 25.85	140 0.0061	53.1 0 0.2	
n65 src1	-3 -3		0 1116.8	8 8.55		30 0 30	140 0.0061	53.2 0 0.2	
h42 h43	21.25 21.25	8 8	30 0.7	1.5 1.68		10 0 10	120 0.0000	14.1 0 0	
h43 h44	21.25 21.25	8 8	30 30.7	1.5 1.68		10 0 10	120 0.029	14.1 0 0.3	
h44 n15	21.25 21.25	8	30.3 61	1.5 1.68	1x(us.Tee-Br)=9.84	32.08 9.84 41.92	120 0.1033	14.4 0 4.3	
n15 n16	21.25 19.25		0 61	1.5 1.68	1x(us.Tee-Br)=9.84	2 9.84 11.84	120 0.1033	18.7 0.9 1.2	
n16 n20	19.25 19.25		27.3 88.3	2.5 2.635		10 0 10	120 0.0229	20.8 0 0.2	
n20 n24	19.25 19.25		61.6 149.9	2.5 2.635		10 0 10	120 0.061	21 0 0.6	
n24 n28	19.25 19.25		63.4 213.3	2.5 2.635		10 0 10	120 0.1171	21.6 0 1.2	
n28 n32	19.25 19.25		-32.4 180.9	2.5 2.635		10 0 10	120 0.0863	22.8 0 0.9	
n32 n74	19.25 19.25		-29.4 151.5	2.5 2.635		4.5 0 4.5	120 0.0621	23.6 0 0.3	
n74 n73	19.25 19.96		-59.7 91.8	2.5 2.635	1x(us.90)=8.24 1x(us.Tee-Br)=16.47	0.71 24.71 25.42	120 0.0246	23.9 -0.3 0.6	
n73 n72	19.96 19.96		0 91.8	2.5 2.635	1x(us.90)=8.24	105.33 8.24 113.57	120 0.0246	24.2 0 2.8	
n72 n71	19.96 19.25		0 91.8	2.5 2.635	1x(us.Tee-Br)=16.47	0.71 16.47 17.18	120 0.0246	27 0.3 0.4	
n71 n41	19.25 19.25		59.7 151.5	4 4.26	1x(us.Tee-Br)=26.33	1.5 26.33 27.83	120 0.006	27.8 0 0.2	
n41 n53	19.25 19.25		247.4 398.9	4 4.26	1x(us.90)=13.17	10 13.17 23.17	120 0.036	27.9 0 0.8	

PIPE INFORMATION

Node 1 Node 2	Elev 1 Elev 2	K-Factor 1 K-Factor 2	Flow added (q)* Total flow (Q)	Nominal ID Actual ID	Fittings quantity x (name) = length	L F T	C Factor Pf per ft	total (Pt) elev (Pe) frict (Pf)	NOTES
	(ft)	(gpm/psi ^{1/2})	(gpm)	(in)	(ft)	(ft)	(psi)	(psi)	
n53 n54	19.25 19.25		0 398.9	4 4.26	1x(us.90)=13.17	10 13.17 23.17	120 0.036	28.8 0 0.8	
n54 n55	19.25 19.25		0 398.9	4 4.26	1x(us.Tee-Br)=26.33	78 26.33 104.33	120 0.036	29.6 0 3.8	
h54 h53	21.25 21.25	8 8	30.1 29.1	1.5 1.68		10 0 10	120 0.0262	14.2 0 0.3	
h53 h52	21.25 21.25	8 8	30.4 59.5	1.5 1.68		10 0 10	120 0.0985	14.4 0 1	
h52 n17	21.25 21.25	8	31.4 90.9	1.5 1.68	1x(us.90)=4.92	33.25 4.92 38.17	120 0.216	15.4 0 8.2	
n17 n18	21.25 19.25		0 90.9	1.5 1.68	1x(us.Tee-Br)=9.84	2 9.84 11.84	120 0.216	23.7 0.9 2.6	
h54 h55	21.25 21.25	8 8	30.1 1.1	1.5 1.68		10 0 10	120 0.0001	14.2 0 0	
h55 h56	21.25 21.25	8 8	30.1 31.2	1.5 1.68		10 0 10	120 0.0298	14.2 0 0.3	
h56 n19	21.25 21.25	8	30.4 61.6	1.5 1.68	1x(us.Tee-Br)=9.84	32.08 9.84 41.92	120 0.1052	14.5 0 4.4	
n19 n20	21.25 19.25		0 61.6	1.5 1.68	1x(us.Tee-Br)=9.84	2 9.84 11.84	120 0.1052	18.9 0.9 1.2	
h66 h65	21.25 21.25	8 8	30.4 28.2	1.5 1.68		10 0 10	120 0.0248	14.5 0 0.2	
h65 h64	21.25 21.25	8 8	30.7 58.9	1.5 1.68		10 0 10	120 0.0968	14.7 0 1	
h64 n21	21.25 21.25	8	31.7 90.6	1.5 1.68	1x(us.90)=4.92	33.25 4.92 38.17	120 0.2148	15.7 0 8.2	
n21 n22	21.25 19.25		0 90.6	1.5 1.68	1x(us.Tee-Br)=9.84	2 9.84 11.84	120 0.2148	23.9 0.9 2.5	
n22 n26	19.25 19.25		94.9 185.6	4 4.26		10 0 10	120 0.0087	27.3 0 0.1	
n26 n30	19.25 19.25		32.4 217.9	4 4.26		10 0 10	120 0.0117	27.4 0 0.1	
n30 n41	19.25 19.25		29.4 247.4	4 4.26	1x(us.Tee-Br)=26.33	3 26.33 29.33	120 0.0149	27.5 0 0.4	
h66 h67	21.25 21.25	8 8	30.4 2.2	1.5 1.68		10 0 10	120 0.0002	14.5 0 0	

PIPE INFORMATION

Node 1 Node 2	Elev 1 Elev 2	K-Factor 1 K-Factor 2	Flow added(q)* Total flow (Q)	Nominal ID Actual ID	Fittings quantity x (name) = length	L F T	C Factor Pf per ft	total (Pt) elev (Pe) frict (Pf)	NOTES
	(ft)	(gpm/psi ^{1/2})	(gpm)	(in)	(ft)	(ft)	(psi)	(psi)	
h67 h68	21.25 21.25	8 8	30.4 32.6	1.5 1.68		10 0 10	120 0.0323	14.5 0 0.3	
h68 n23	21.25 21.25	8	30.8 63.4	1.5 1.68	1x(us.Tee-Br)=9.84	32.08 9.84 41.92	120 0.1107	14.8 0 4.6	
n23 n24	21.25 19.25		0 63.4	1.5 1.68	1x(us.Tee-Br)=9.84	2 9.84 11.84	120 0.1107	19.4 0.9 1.3	
h30 h29	21.25 21.25	8 8	31.3 22.2	1.5 1.68		10 0 10	120 0.0159	15.3 0 0.2	
h29 h28	21.25 21.25	8 8	31.5 53.7	1.5 1.68		10 0 10	120 0.0815	15.5 0 0.8	
h28 n9	21.25 21.25	8	32.3 86	1.5 1.68	1x(us.90)=4.92	33.25 4.92 38.17	120 0.195	16.3 0 7.4	
n9 n10	21.25 19.25		0 86	1.5 1.68	1x(us.Tee-Br)=9.84	2 9.84 11.84	120 0.195	23.8 0.9 2.3	
n10 n14	19.25 19.25		45.1 131.1	4 4.26		10 0 10	120 0.0046	26.9 0 0.0	
h30 h31	21.25 21.25	8 8	31.3 9.1	1.5 1.68		10 0 10	120 0.0031	15.3 0 0.0	
h31 h32	21.25 21.25	8 8	31.4 40.5	1.5 1.68		10 0 10	120 0.0483	15.4 0 0.5	
h32 n50	21.25 21.25	8	31.9 72.3	1.5 1.68	1x(us.90)=4.92	11 4.92 15.92	120 0.1415	15.9 0 2.3	
n50 n52	21.25 19.25		0 72.3	1.5 1.68	1x(us.Tee-Br)=9.84	2 9.84 11.84	120 0.1415	18.1 0.9 1.7	
n52 n48	19.25 19.25		-27.3 45.1	2.5 2.635	1x(us.90)=8.24	18.5 8.24 26.73	120 0.0066	20.6 0 0.2	
n48 n47	19.25 21.25		0 45.1	1.5 1.68	1x(us.90)=4.92	2 4.92 6.92	120 0.0589	20.8 -0.9 0.4	
n47 n46	21.25 21.25		0 45.1	1.5 1.68	1x(us.90)=4.92	10.89 4.92 15.81	120 0.0589	20.4 0 0.9	
n46 n45	21.25 21.25		0 45.1	1.5 1.68	1x(us.90)=4.92	3 4.92 7.92	120 0.0589	21.3 0 0.5	
n45 n5	21.25 21.25		0 45.1	1.5 1.68	1x(us.90)=4.92	56.25 4.92 61.17	120 0.0589	21.8 0 3.6	
n5 n6	21.25 19.25		0 45.1	1.5 1.68	1x(us.Tee-Br)=9.84	2 9.84 11.84	120 0.0589	25.4 0.9 0.7	

PIPE INFORMATION

Node 1 Node 2	Elev 1 Elev 2	K-Factor 1 K-Factor 2	Flow added(q)* Total flow (Q)	Nominal ID Actual ID	Fittings quantity x (name) = length	L F T	C Factor Pf per ft	total (Pt) elev (Pe) frict (Pf)	NOTES
	(ft)	(gpm/psi ^{1/2})	(gpm)	(in)	(ft)	(ft)	(psi)	(psi)	
n6 n10	19.25 19.25		0 45.1	4 4.26		10 0 10	120 0.0006	26.9 0 0	
n70 n22	19.25 19.25		0 94.9	4 4.26		2 0 2	120 0.0025	27.3 0 0	
n28 n27	19.25 21.25		0 32.4	1.5 1.68	2x(us.Tee-Br)=19.68	2 19.68 21.68	120 0.0319	22.8 -0.9 0.7	
n27 n25	21.25 21.25		0 32.4	1.5 1.68	1x(us.90)=4.92	105.33 4.92 110.25	120 0.0319	22.6 0 3.5	
n25 n26	21.25 19.25		0 32.4	1.5 1.68	1x(us.Tee-Br)=9.84	2 9.84 11.84	120 0.0319	26.1 0.9 0.4	
n32 n31	19.25 21.25		0 29.4	1.5 1.68	2x(us.Tee-Br)=19.68	2 19.68 21.68	120 0.0268	23.6 -0.9 0.6	
n31 n29	21.25 21.25		0 29.4	1.5 1.68	1x(us.90)=4.92	105.33 4.92 110.25	120 0.0268	23.4 0 3	
n29 n30	21.25 19.25		0 29.4	1.5 1.68	1x(us.Tee-Br)=9.84	2 9.84 11.84	120 0.0268	26.3 0.9 0.3	
n74 n36	19.25 19.25		0 59.7	2.5 2.635		5.5 0 5.5	120 0.0111	23.9 0 0.1	
n36 n40	19.25 19.25		-29.1 30.6	2.5 2.635	1x(us.90)=8.24	10 8.24 18.24	120 0.0032	24 0 0.1	
n40 n39	19.25 21.25		0 30.6	1.5 1.68	1x(us.Tee-Br)=9.84	2 9.84 11.84	120 0.0287	24 -0.9 0.3	
n39 n37	21.25 21.25		0 30.6	1.5 1.68	1x(us.90)=4.92	105.33 4.92 110.25	120 0.0287	23.5 0 3.2	
n37 n38	21.25 19.25		0 30.6	1.5 1.68	1x(us.90)=4.92	2 4.92 6.92	120 0.0287	26.7 0.9 0.2	
n38 n34	19.25 19.25		0 30.6	4 4.26		10 0 10	120 0.0003	27.8 0 0	
n34 n71	19.25 19.25		29.1 59.7	4 4.26		5.5 0 5.5	120 0.0011	27.8 0 0	
n52 n51	19.25 19.25		0 27.3	2.5 2.635	1x(us.Tee-Br)=16.47	7.92 16.47 24.39	120 0.0026	20.6 0 0.1	
n51 n49	19.25 19.25		0 27.3	2.5 2.635	1x(us.90)=8.24	14.99 8.24 23.23	120 0.0026	20.7 0 0.1	
n49 n16	19.25 19.25		0 27.3	2.5 2.635		1 0 1	120 0.0026	20.8 0 0	

Job name:

Sheet number: _____

PIPE INFORMATION

Node 1 Node 2	Elev 1 Elev 2	K-Factor 1 K-Factor 2	Flow added (q)* Total flow (Q)	Nominal ID Actual ID	Fittings quantity x (name) = length	L F T	C Factor Pf per ft	total (Pt) elev (Pe) frict (Pf)	NOTES
	(ft)	(gpm/psi ^{1/2})	(gpm)	(in)	(ft)	(ft)	(psi)	(psi)	
n36 n35	19.25 21.25		0 29.1	1.5 1.68	2x(us.Tee-Br)=19.68	2 19.68 21.68	120 0.0262	24 -0.9 0.6	
n35 n33	21.25 21.25		0 29.1	1.5 1.68	1x(us.90)=4.92	105.33 4.92 110.25	120 0.0262	23.7 0 2.9	
n33 n34	21.25 19.25		0 29.1	1.5 1.68	1x(us.Tee-Br)=9.84	2 9.84 11.84	120 0.0262	26.6 0.9 0.3	

* Discharge shown for flowing nodes only

Portland Water Bureau

TO:	Null	FROM:	Jamie Wilde
COMPANY:	Null		Portland Water Bureau
FAX:	Null	PHONE:	503-823-9083
PHONE:	Null	DATE:	4/30/2014
EMAIL:	Null	# PAGES:	0

Fire Flow Availability Estimate

A hydrant flow test was not available or could not be completed at the requested location. This is an estimated flow obtained using a hydraulic

Simulation for the 8-inch main at NE 57th Avenue & Hassalo Street.

Simulation ID Number:	1178
Assumed fire service location:	910 NE 57th Avenue
Map Number (quartersection):	2936
Pressure Zone:	TABOR 411
Main size:	8 inch
Assumed fire service elevation:	207 feet
Maximum Static Hydraulic Grade Line:	411 feet
Maximum Static Pressure:	88 psi
STATIC PRESSURE to use for design: (80% of the nominal max static pressure)	71 psi
ESTIMATED FLOW:	2500 gpm
ESTIMATED RESIDUAL PRESSURE: (in the system, with the simulated flow)	49 psi

NOTE: The Water Bureau reserves the right to make future operational changes that may affect flow available at this location. The reported flow is available in the main before any service pipe, backflow prevention device, or meter. Less flow may be available through a hydrant at the given residual pressure.

Subject: Fire Flow Request - 5600 NE Hassalo St.
From: Kristina Zook (k.zook@wyattfire.com)
To: sunriver97707@yahoo.com;
Date: Wednesday, April 30, 2014 3:51 PM

Hi Bruce,

Attached is the flow info from Portland for the 5600 NE Hassalo St. The information is also listed below.

Thank you,

Kristina Zook
Wyatt Fire Protection

STATIC PRESSURE to use for design: 71 psi
(80% of the nominal max static pressure)
ESTIMATED FLOW: 2500 gpm
ESTIMATED RESIDUAL PRESSURE: 49 psi
(in the system, with the simulated flow)

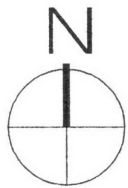
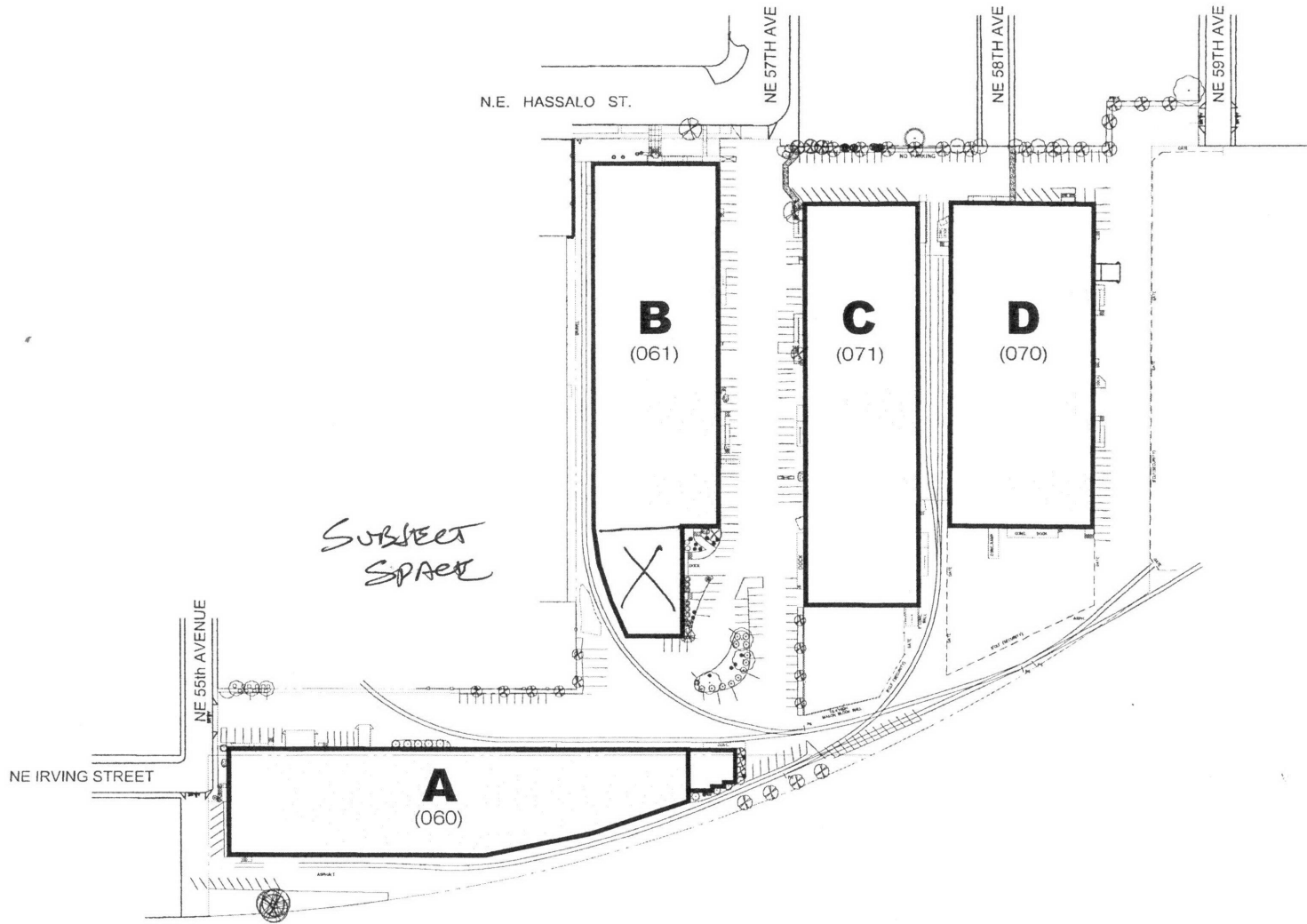

SCALE 1" = 200'

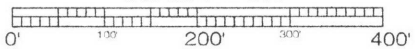

A FACTRUST PROPERTY

BANFIELD INDUSTRIAL PARK
 PORTLAND, OR 97213

4/1/10



Series 2000SE

Double Check Valve Assemblies

Sizes: 6" and 8" (150 and 200mm)

Features

- Short lay length makes retrofit easy
- Patented cam-check valve provides low headloss
- Stainless steel body is half the weight of competitive designs reducing installation and shipping costs
- Stainless steel body provides long term corrosion protection and maximum strength
- Easy maintenance via top mounted single access cover
- No special tools required for servicing
- Compact construction for smaller valve vaults and enclosures

Available Models

Suffix:

- NRS - non-rising stem resilient seated gate valves
- OSY - UL/FM outside stem and yoke resilient seated gate valves
- LG - without shutoff valves

Materials

All internal metal parts: 300 Series stainless steel

Main valve body: 300 Series stainless steel

Check assembly: Noryl®

Flange dimension in accordance with AWWA Class D

Noryl® is a registered trademark of General Electric Company.

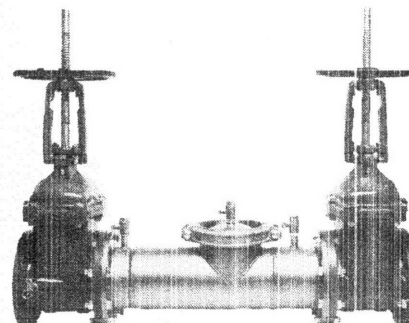

2000SE

Series 2000SE Double Check Valve Assemblies are designed to prevent the reverse flow of polluted water from entering the potable water supply. These models can be applied, where approved by the local authority having jurisdiction, on non health hazard installations.

The Series 2000SE consists of two independently operating cam-check valves located between two resilient seated shutoffs with four ball valve type test cocks.

Specifications

The Double Check Valve Assembly shall consist of two positive seating cam-check valves located between two resilient seated shutoffs with four ball valve type test cocks. The main valve body shall be manufactured from 300 Series stainless steel to provide corrosion resistance. The cam-check valves shall be of thermoplastic construction with stainless steel hinge pins, cam arm and cam bearing. The cam-check valves shall utilize a single torsion spring design to minimize pressure drop through the assembly. The check valves shall be modular and shall seal to the main valve body by the use of an O-ring. There shall be no brass or bronze parts used within the check valve assembly. The cam-check valve seats shall be of molded thermoplastic construction. The use of seat screws as a retention method is prohibited. All internal parts shall be accessible through a single cover on the valve assembly. The valve cover shall be held in place through the use of a single grooved style two-bolt coupling. The assembly shall be an Ames Company Series 2000SE.

Job Name _____ Contractor _____

Job Location _____ Approval _____

Engineer _____ Contractor's P.O. No. _____

Approval _____ Representative _____

Ames product specifications in U.S. customary units and metric are approximate and are provided for reference only. For precise measurements, please contact Ames Technical Service. Ames reserves the right to change or modify product design, construction, specifications, or materials without prior notice and without incurring any obligation to make such changes and modifications on Ames products previously or subsequently sold.

www.amesfirewater.com

Pressure — Temperature

Temperature Range: 33°F – 110°F (5°C – 43°C)
 Maximum Working Pressure: 175psi (12.06 bars)

Approvals



Standards

AWWA C510-92

IMPORTANT: Inquire with governing authorities for local installation requirements.

Dimensions – Weights

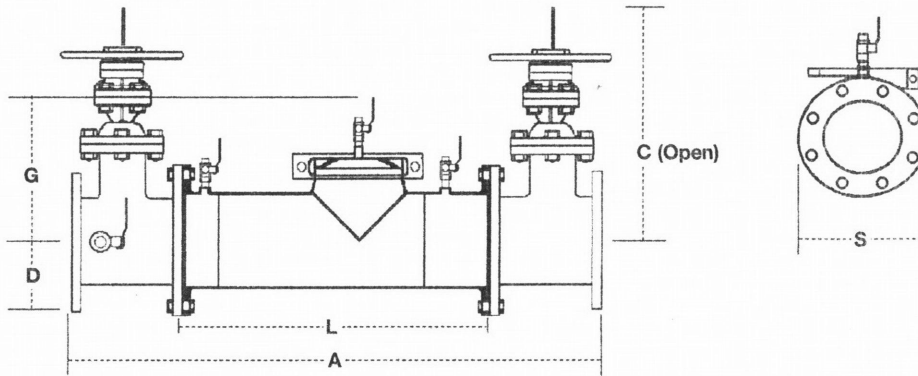

SIZE	DIMENSIONS							WEIGHT	
	A	C (OSY)	C(NRS)	D	G	L	S	w/Gates	w/o Gates
in. mm	in. mm	in. mm	in. mm	in. mm	in. mm	in. mm	in. mm	lb. kg	lb. kg
6 150	41½ 1054	30¾ 765	16 406	5½ 140	11½ 283	20 508	11 279	328 149	58 26
8 200	52½ 1334	37¾ 959	19½ 506	6¾ 171	17½ 445	29½ 749	13½ 343	540 245	120 54

Capacities

*UL Rated **UL Tested

Series 2000SE flow curves as tested by Underwriters (including shutoffs)

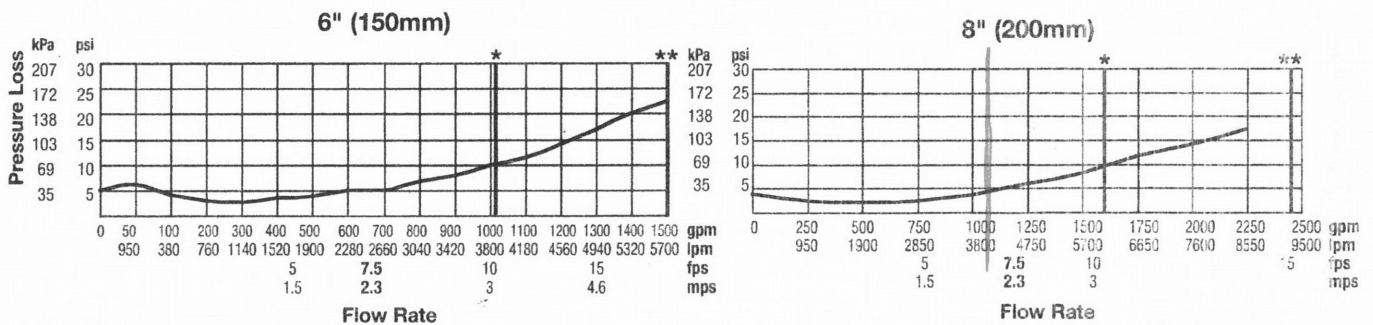

www.amesfirewater.com



1427 North Market Blvd. • Suite #9 • Sacramento, CA 95834 • Phone: 916-928-0123 • Fax: 916-928-9333

ES-A-2000SE 0508

©Ames Co. 2005

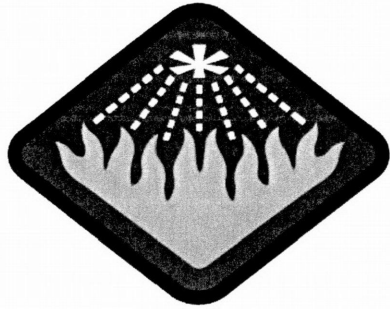

WYATT

FIRE PROTECTION, INC.

9095 S.W. Burnham

Tigard, OR 97223

**BANFIELD INDUSTRIAL
PARK**

BUILDING D

5600 NE HASSALO DRIVE

PORTLAND, OREGON

**FIRE PROTECTION
EQUIPMENT SUBMITTAL**

14-185 397 FA

Series TY-FRB – 2.8, 4.2, 5.6, and 8.0 K-Factor Upright, Pendent, and Recessed Pendent Sprinklers Quick Response, Standard Coverage

General Description

The TYCO Series TY-FRB, 2.8, 4.2, 5.6, and 8.0 K-factor, Upright, Pendent, and Recessed Pendent Sprinklers described in this data sheet are quick response, standard coverage, decorative 3 mm glass bulb-type spray sprinklers designed for use in light or ordinary hazard, commercial occupancies such as banks, hotels, and shopping malls.

The recessed version of the Series TY-FRB Pendent Sprinkler, where applicable, is intended for use in areas with a finished ceiling. This recessed pendent sprinkler uses one of the following:

- A two-piece Style 10 (1/2 inch NPT) or Style 40 (3/4 inch NPT) Recessed Escutcheon with 1/2 inch (12,7 mm) of recessed adjustment or up to 3/4 inch (19,1 mm) of total adjustment from the flush pendent position, or a
- A two-piece Style 20 (1/2 inch NPT) or Style 30 (3/4 inch NPT) Recessed Escutcheon with 1/4 inch (6,4 mm) of recessed adjustment or up to 1/2 inch (12,7 mm) of total adjustment from the flush pendent position.

The adjustment provided by the Recessed Escutcheon reduces the accuracy to which the fixed pipe drops to the sprinklers must be cut.

Corrosion-resistant coatings, where applicable, are utilized to extend the life of copper alloy sprinklers beyond that which would otherwise be obtained when exposed to corrosive atmo-

spheres. Although corrosion-resistant coated sprinklers have passed the standard corrosion tests of the applicable approval agencies, the testing is not representative of all possible corrosive atmospheres. Consequently, it is recommended that the end user be consulted with respect to the suitability of these coatings for any given corrosive environment. The effects of ambient temperature, concentration of chemicals, and gas/chemical velocity, should be considered, as a minimum, along with the corrosive nature of the chemical to which the sprinklers will be exposed.

An intermediate level of the Series TY-FRB Pendent Sprinklers is detailed in Technical Data Sheet TFP356, and Sprinkler Guards are detailed in Technical Data Sheet TFP780.

NOTICE

The Series TY-FRB, 2.8, 4.2, 5.6, and 8.0 K-factor, Upright, Pendent, and Recessed Pendent Sprinklers described herein must be installed and maintained in compliance with this document and with the applicable standards of the National Fire Protection Association, in addition to the standards of any authorities having jurisdiction. Failure to do so may impair the performance of these devices.

The owner is responsible for maintaining their fire protection system and devices in proper operating condition. The installing contractor or sprinkler manufacturer should be contacted with any questions.

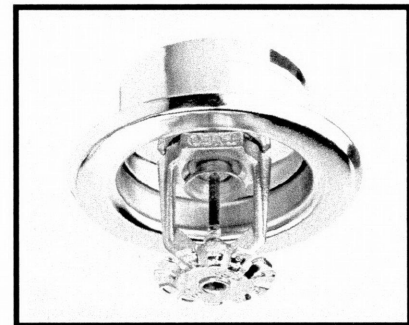
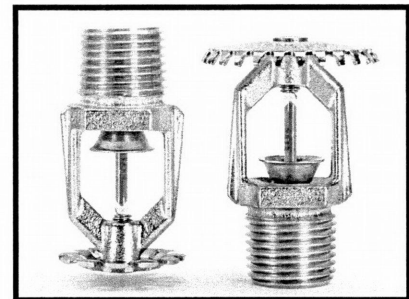

Sprinkler Identification Number (SIN)

TY1131:	Upright	2.8K, 1/2" NPT
TY1231:	Pendent	2.8K, 1/2" NPT
TY2131:	Upright	4.2K, 1/2" NPT
TY2231:	Pendent	4.2K, 1/2" NPT
TY3131:	Upright	5.6K, 1/2" NPT
TY3231:	Pendent	5.6K, 1/2" NPT
TY4131:	Upright	8.0K, 3/4" NPT
TY4231:	Pendent	8.0K, 3/4" NPT
TY4831:	Upright	8.0K, 1/2" NPT
TY4931:	Pendent	8.0K, 1/2" NPT

IMPORTANT

Always refer to Technical Data Sheet TFP700 for the "INSTALLER WARNING" that provides cautions with respect to handling and installation of sprinkler systems and components. Improper handling and installation can permanently damage a sprinkler system or its components and cause the sprinkler to fail to operate in a fire situation or cause it to operate prematurely.

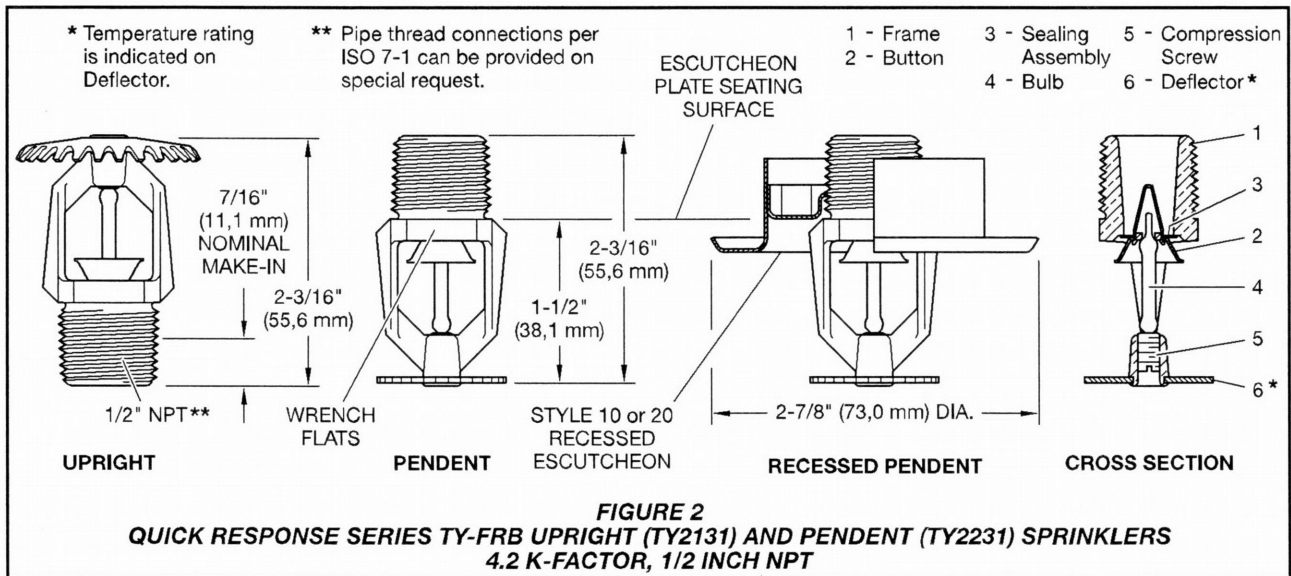
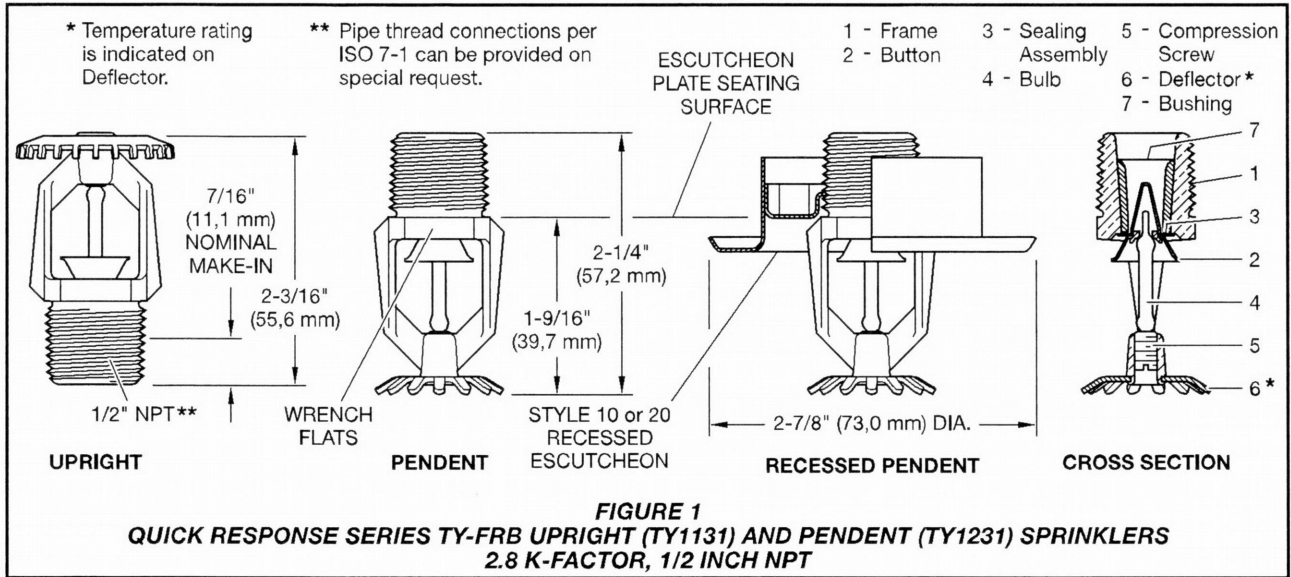

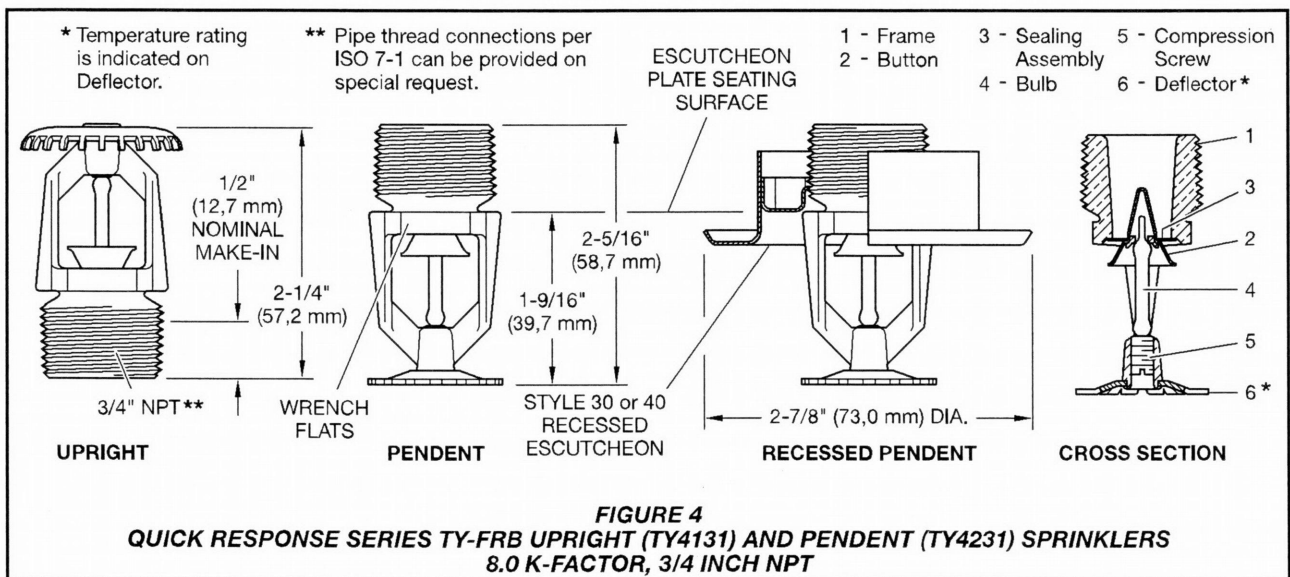
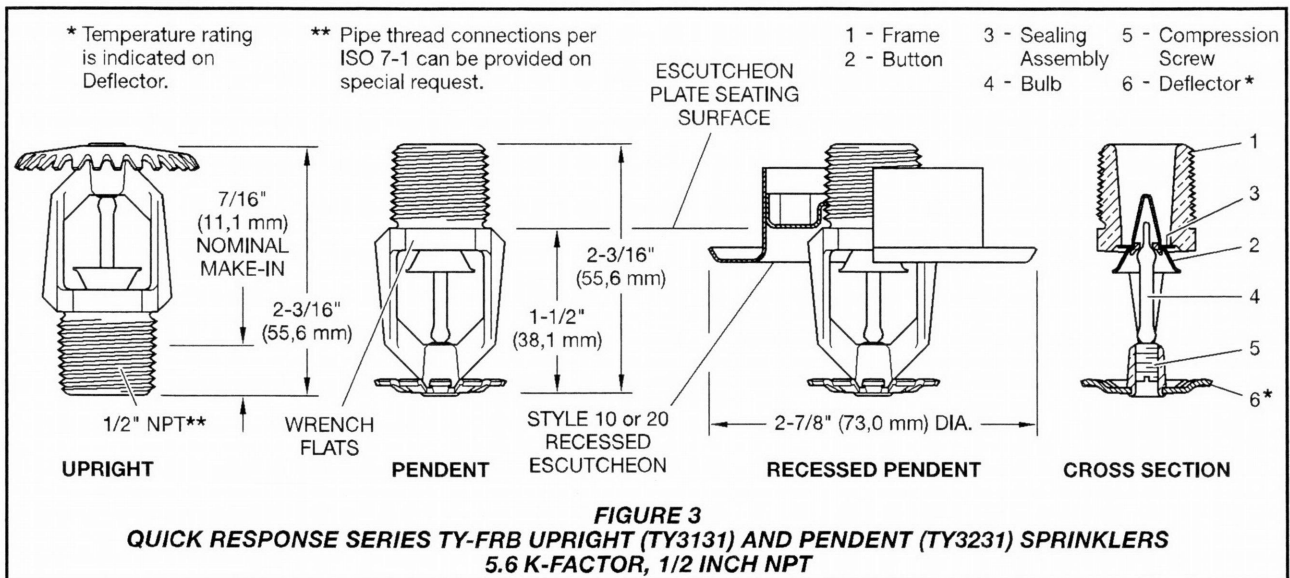

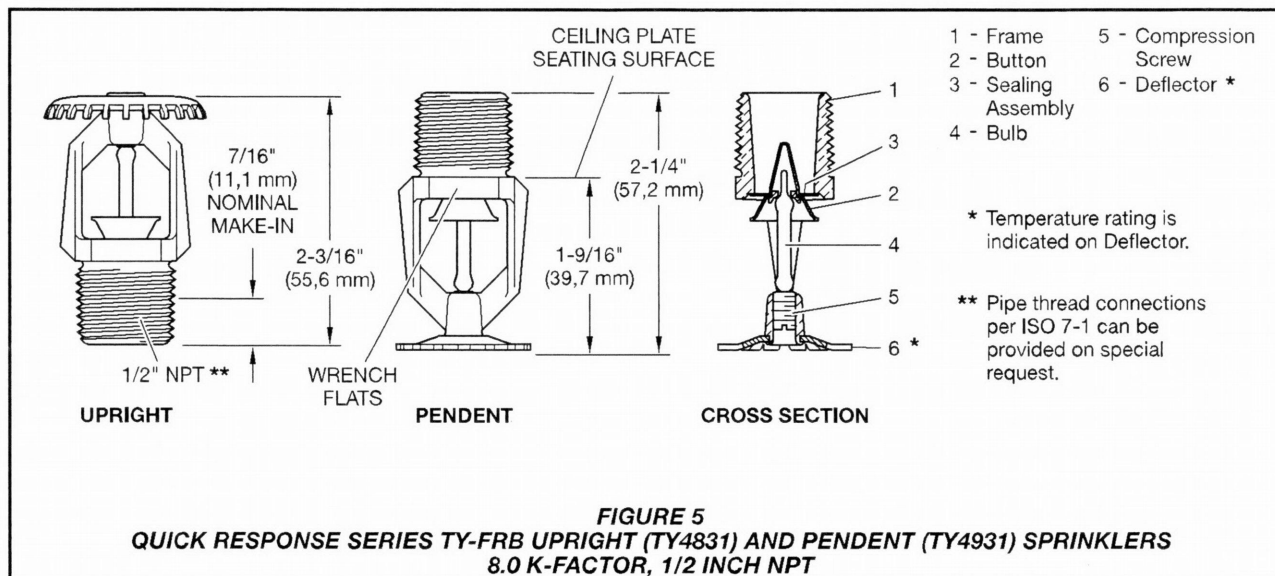

Technical Data

Approvals

UL and C-UL Listed
FM, LPCB, and NYC Approved
Refer to Table A and B for complete approval information including corrosion-resistant status.

Maximum Working Pressure

Refer to Table C.

Discharge Coefficient

K=2.8 GPM/psi^{1/2} (40,3 LPM/bar^{1/2})
K=4.2 GPM/psi^{1/2} (60,5 LPM/bar^{1/2})
K=5.6 GPM/psi^{1/2} (80,6 LPM/bar^{1/2})
K=8.0 GPM/psi^{1/2} (115,2 LPM/bar^{1/2})

Temperature Rating

Refer to Table A and B.

Finishes

Sprinkler: Refer to Table D. Recessed Escutcheon: White Coated, Chrome Plated, or Brass Plated.

Physical Characteristics

Frame Bronze
Button Brass/Copper
Sealing Assembly. Beryllium Nickel w/TEFLON
Bulb Glass
Compression Screw. Bronze
Deflector. Copper/Bronze
Bushing (K=2.8) Bronze

Operation

The glass bulb contains a fluid that expands when exposed to heat. When the rated temperature is reached, the fluid expands sufficiently to shatter the glass bulb, allowing the sprinkler to activate and water to flow.

Design Criteria

The TYCO Series TY-FRB, 2.8, 4.2, 5.6, and 8.0 K-factor, Upright, Pendent, and Recessed Pendent Sprinklers are intended for fire protection systems designed in accordance with the standard installation rules recognized by the applicable Listing or Approval agency (such as, UL Listing is based on the requirements of NFPA 13, and FM Approval is based on the requirements of FM's Loss Prevention Data Sheets). Only the Style 10, 20, 30, or 40 Recessed Escutcheon, as applicable, is to be used for recessed pendent installations.

Installation

The TYCO Series TY-FRB, 2.8, 4.2, 5.6, and 8.0 K-factor, Upright, Pendent, and Recessed Pendent Sprinklers must be installed in accordance with this section.

General Instructions

Do not install any bulb-type sprinkler if the bulb is cracked or there is a loss of liquid from the bulb. With the sprinkler held horizontally, a small air bubble should be present. The diameter of the air bubble is approximately 1/16 inch (1,6 mm) for the 135°F (57°C) and 3/32 inch (2,4 mm) for the 286°F (141°C) temperature ratings.

A leak-tight 1/2 inch NPT sprinkler joint should be obtained by applying a minimum to maximum torque of 7 to 14 ft.-lbs. (9,5 to 19,0 Nm). A leak tight 3/4 inch NPT sprinkler joint should be obtained with a torque of 10 to 20 ft.-lbs. (13,4 to 26,8 Nm). Higher levels of

torque can distort the sprinkler Inlet with consequent leakage or impairment of the sprinkler.

Do not attempt to compensate for insufficient adjustment in the Escutcheon Plate by under- or over-tightening the sprinkler. Re-adjust the position of the sprinkler fitting to suit.

Series TY-FRB Upright and Pendent Sprinklers

The Series TY-FRB Pendent and Upright Sprinklers must be installed in accordance with the following instructions.

Step 1. Install Pendent sprinklers in the pendent position. Install upright sprinklers in the upright position.

Step 2. With pipe-thread sealant applied to the pipe threads, hand-tighten the sprinkler into the sprinkler fitting.

Step 3. Tighten the sprinkler into the sprinkler fitting using only the W-Type 6 Sprinkler Wrench (Figure 14). With reference to Figures 1 through 5, apply the W-Type 6 Sprinkler Wrench to the sprinkler wrench flats.

Series TY-FRB Recessed Pendent Sprinklers

The Series TY-FRB Recessed Pendent Sprinklers must be installed in accordance with the following instructions.

Step A. After installing the Style 10, 20, 30, or 40 Mounting Plate, as applicable, over the sprinkler threads and with pipe-thread sealant applied to the pipe threads, hand-tighten the sprinkler into the sprinkler fitting.

Step B. Tighten the sprinkler into the sprinkler fitting using only the W-Type 7 Recessed Sprinkler Wrench (Figure

K FACTOR	TYPE	TEMPERATURE	SPRINKLER FINISH (See Note 5)			
			BULB LIQUID COLOR	NATURAL BRASS	CHROME PLATED	SIGNAL*** WHITE
2.8 1/2" NPT	PENDENT (TY1231) and UPRIGHT (TY1131)	135°F (57°C)	Orange		1, 2, 3, 4	
		155°F (68°C)	Red			
		175°F (79°C)	Yellow			
		200°F (93°C)	Green			
		286°F (141°C)	Blue			
	RECESSED PENDENT (TY1231)* Figure 6	135°F (57°C)	Orange			
		155°F (68°C)	Red			
		175°F (79°C)	Yellow			
		200°F (93°C)	Green			
	RECESSED PENDENT (TY1231)** Figure 7	135°F (57°C)	Orange			
		155°F (68°C)	Red			
		175°F (79°C)	Yellow			
200°F (93°C)		Green				
4.2 1/2" NPT	PENDENT (TY2231) and UPRIGHT (TY2131)	135°F (57°C)	Orange		1, 2	
		155°F (68°C)	Red			
		175°F (79°C)	Yellow			
		200°F (93°C)	Green			
		286°F (141°C)	Blue			
	RECESSED PENDENT (TY2231)* Figure 8	135°F (57°C)	Orange			
		155°F (68°C)	Red			
		175°F (79°C)	Yellow			
		200°F (93°C)	Green			
	RECESSED PENDENT (TY2231)** Figure 9	135°F (57°C)	Orange			
		155°F (68°C)	Red			
		175°F (79°C)	Yellow			
200°F (93°C)		Green				

NOTES:

1. Listed by Underwriters Laboratories, Inc., (UL) as Quick Response Sprinklers.
2. Listed by Underwriters Laboratories, Inc., for use in Canada (C-UL) as Quick Response Sprinklers.
3. Approved by Factory Mutual Research Corporation (FM) as Quick Response Sprinklers.
4. Approved by the City of New York under MEA 354-01-E.
5. Where Polyester Coated Sprinklers are noted to be UL and C-UL Listed, the sprinklers are UL and C-UL Listed as Corrosion-Resistant Sprinklers.

* Installed with Style 10 (1/2" NPT) or Style 40 (3/4" NPT) 3/4" Total Adjustment Recessed Escutcheon, as applicable.

** Installed with Style 20 (1/2" NPT) or Style 30 (3/4" NPT) 1/2" Total Adjustment Recessed Escutcheon, as applicable.

*** Frame and Deflector only. Listings and approvals apply to color (Special Order).

N/A: Not Available

**TABLE A
LABORATORY LISTINGS AND APPROVALS FOR
2.8 AND 4.2 K-FACTOR SPRINKLERS**

15). With reference to Figures 1 to 4, apply the W-Type 7 Recessed Sprinkler Wrench to the sprinkler wrench flats.

Step C. After ceiling installation and finishing, slide on the Style 10, 20, 30, or 40 Closure over the Series TY-FRB Sprinkler and push the Closure over the Mounting Plate until its flange comes in contact with the ceiling.

K FACTOR	TYPE	TEMPERATURE	SPRINKLER FINISH (See Note 8)				
			BULB LIQUID COLOR	NATURAL BRASS	CHROME PLATED	SIGNAL*** WHITE	LEAD COATED
5.6 1/2" NPT	PENDENT (TY3231) and UPRIGHT (TY3131)	135°F (57°C)	Orange		1, 2, 3, 4, 5, 6, 7		1, 2, 3, 5
		155°F (68°C)	Red				
		175°F (79°C)	Yellow				
		200°F (93°C)	Green				
		286°F (141°C)	Blue				
	RECESSED PENDENT (TY3231)* Figure 10	135°F (57°C)	Orange		1, 2, 4, 5		N/A
		155°F (68°C)	Red				
		175°F (79°C)	Yellow				
		200°F (93°C)	Green				
	RECESSED PENDENT (TY3231)** Figure 11	135°F (57°C)	Orange		1, 2, 3, 4, 5		N/A
		155°F (68°C)	Red				
		175°F (79°C)	Yellow				
200°F (93°C)		Green					
8.0 3/4" NPT	PENDENT (TY4231) and UPRIGHT (TY4131)	135°F (57°C)	Orange		1, 2, 3, 4, 5, 6, 7		1, 2, 5
		155°F (68°C)	Red				
		175°F (79°C)	Yellow				
		200°F (93°C)	Green				
		286°F (141°C)	Blue				
	RECESSED PENDENT (TY4231)* Figure 12	135°F (57°C)	Orange		1, 2, 5		N/A
		155°F (68°C)	Red				
		175°F (79°C)	Yellow				
		200°F (93°C)	Green				
	RECESSED PENDENT (TY4231)** Figure 13	135°F (57°C)	Orange		1, 2, 3, 5		N/A
		155°F (68°C)	Red				
		175°F (79°C)	Yellow				
200°F (93°C)		Green					
8.0 1/2" NPT	PENDENT (TY4931) and UPRIGHT (TY4831)	135°F (57°C)	Orange		1, 2, 4, 5, 6		1, 2, 5
		155°F (68°C)	Red				
		175°F (79°C)	Yellow				
		200°F (93°C)	Green				
		286°F (141°C)	Blue				

NOTES:

1. Listed by Underwriters Laboratories, Inc., (UL) as Quick Response Sprinklers.
2. Listed by Underwriters Laboratories, Inc., for use in Canada (C-UL) as Quick Response Sprinklers.
3. Approved by Factory Mutual Research Corporation (FM) as Quick Response Sprinklers.
4. Approved by the Loss Prevention Certification Board (LPCB Ref. No. 007k/04) as Quick Response Sprinklers. However, LPCB does not rate the thermal sensitivity of recessed sprinklers.
5. Approved by the City of New York under MEA 354-01-E.
6. VdS Approved (For details, contact Tyco Fire Suppression & Building Products, Enschede, Netherlands, Tel. 31-53-428-4444/Fax 31-53-428-3377).
7. Approved by the Loss Prevention Certification Board (LPCB Ref. No. 094a/06) as Quick Response Sprinklers.
8. Where Polyester Coated and Lead-Coated Sprinklers are noted to be UL and C-UL Listed, the sprinklers are UL and C-UL Listed as Corrosion-Resistant Sprinklers. Where Lead-Coated Sprinklers are noted to be FM Approved, the sprinklers are FM Approved as a Corrosion-Resistant Sprinklers.

* Installed with Style 10 (1/2" NPT) or Style 40 (3/4" NPT) 3/4" Total Adjustment Recessed Escutcheon, as applicable.

** Installed with Style 20 (1/2" NPT) or Style 30 (3/4" NPT) 1/2" Total Adjustment Recessed Escutcheon, as applicable.

*** Frame and Deflector only. Listings and approvals apply to color (Special Order).

N/A: Not Available

**TABLE B
LABORATORY LISTINGS AND APPROVALS FOR
5.6 AND 8.0 K-FACTOR SPRINKLERS**

K FACTOR	TYPE	SPRINKLER FINISH			
		NATURAL BRASS	CHROME PLATED	SIGNAL WHITE	LEAD COATED
2.8 1/2" NPT	PENDENT (TY1231) and UPRIGHT (TY1131)	175 PSI (12,1 BAR)			N/A
	RECESSED PENDENT (TY1231)				
4.2 1/2" NPT	PENDENT (TY2231) and UPRIGHT (TY2131)	175 PSI (12,1 BAR)			N/A
	RECESSED PENDENT (TY2231)				
5.6 1/2" NPT	PENDENT (TY3231) and UPRIGHT (TY3131)	250 PSI (17,2 BAR) OR 175 PSI (12,1 BAR) (SEE NOTE 1)			175 PSI (12,1 BAR)
	RECESSED PENDENT (TY3231)				N/A
8.0 3/4" NPT	PENDENT (TY4231) and UPRIGHT (TY4131)	175 PSI (12,1 BAR)			175 PSI (12,1 BAR)
	RECESSED PENDENT (TY4231)				N/A
8.0 1/2" NPT	PENDENT (TY4931) and UPRIGHT (TY4831)	175 PSI (12,1 BAR)			175 PSI (12,1 BAR)

NOTES:
1. The maximum working pressure of 250 psi (17,2 bar) only applies to the Listing by Underwriters Laboratories Inc. (UL); the Listing by Underwriters Laboratories, Inc. for use in Canada (C-UL); and, the Approval by the City of New York.

TABLE C
MAXIMUM WORKING PRESSURE

Care and Maintenance

The TYCO Series TY-FRB must be maintained and serviced in accordance with this section.

Before closing a fire protection system main control valve for maintenance work on the fire protection system that it controls, obtain permission to shut down the affected fire protection systems from the proper authorities and notify all personnel who may be affected by this action.

Absence of the outer piece of an escutcheon, which is used to cover a clearance hole, can delay sprinkler operation in a fire situation.

Sprinklers which are found to be leaking or exhibiting visible signs of corrosion must be replaced.

Automatic sprinklers must never be painted, plated, coated, or otherwise altered after leaving the factory. Modified sprinklers must be replaced. Sprinklers that have been exposed to

corrosive products of combustion, but have not operated, should be replaced if they cannot be completely cleaned by wiping the sprinkler with a cloth or by brushing it with a soft bristle brush.

Care must be exercised to avoid damage to the sprinklers - before, during, and after installation. Sprinklers damaged by dropping, striking, wrench twist/slippage, or the like, must be replaced. Also, replace any sprinkler that has a cracked bulb or that has lost liquid from its bulb. (Ref. Installation Section.)

The owner is responsible for the inspection, testing, and maintenance of their fire protection system and devices in compliance with this document, as well as with the applicable standards of the National Fire Protection Association (e.g., NFPA 25), in addition to the standards of any other authorities having jurisdiction. Contact the installing contractor or sprinkler manufacturer regarding any questions.

Automatic sprinkler systems are recommended to be inspected, tested, and maintained by a qualified Inspec-

tion Service in accordance with local requirements and/or national codes.

Care must be exercised to avoid damage to the sprinklers -before, during, and after installation. Sprinklers damaged by dropping, striking, wrench twist/slippage, or the like, must be replaced. Also, replace any sprinkler that has a cracked bulb or that has lost liquid from its bulb. (Ref. Installation Section).

Initial and frequent visual inspections of random samples are recommended for corrosion-resistant sprinklers to verify the integrity of the corrosion-resistant material of construction. Thereafter, annual inspections per NFPA 25 should suffice.

Inspections of corrosion-resistant sprinklers are recommended at close range, instead of from the floor level per NFPA. Inspection at close range can better determine the exact sprinkler condition and the long-term integrity of the corrosion-resistant material, which can be affected by the corrosive conditions present.

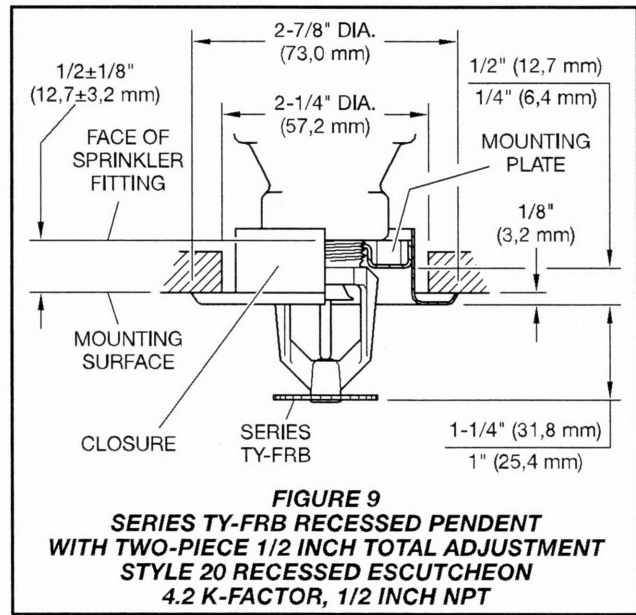
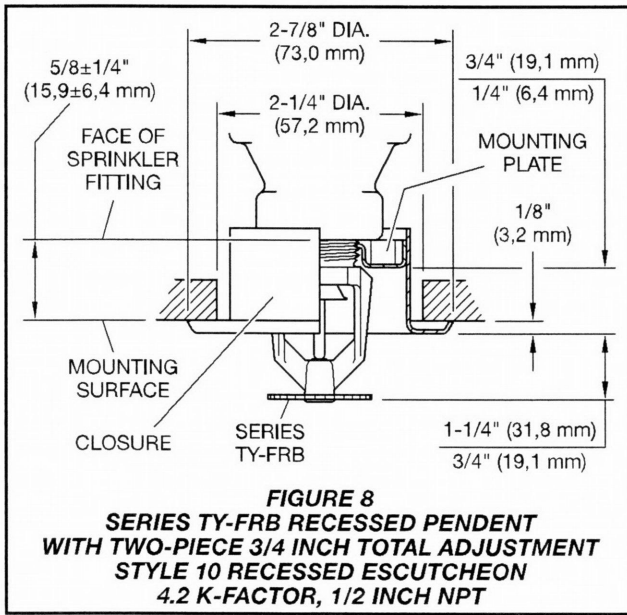
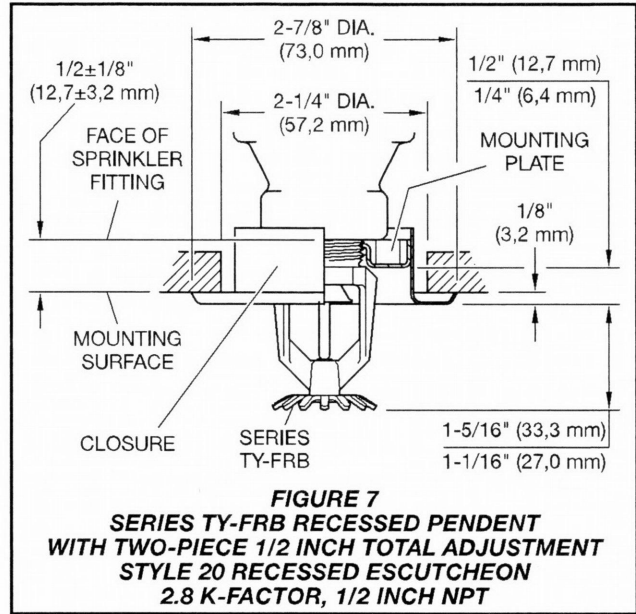
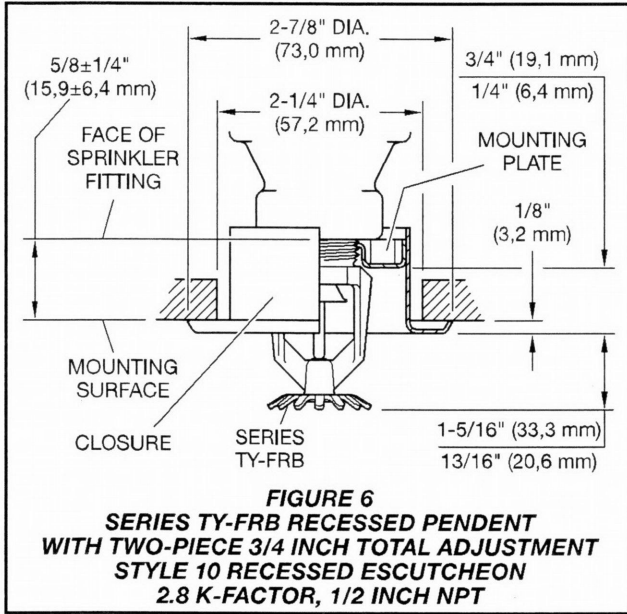

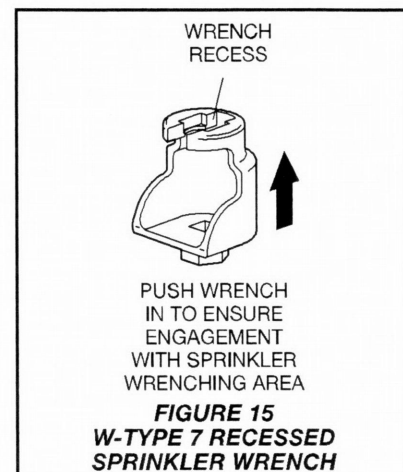
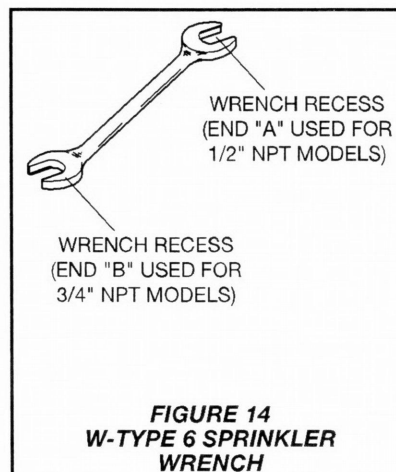
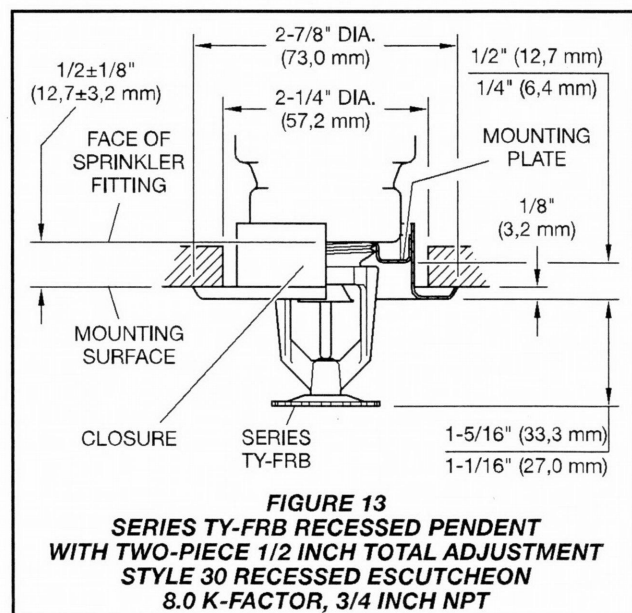
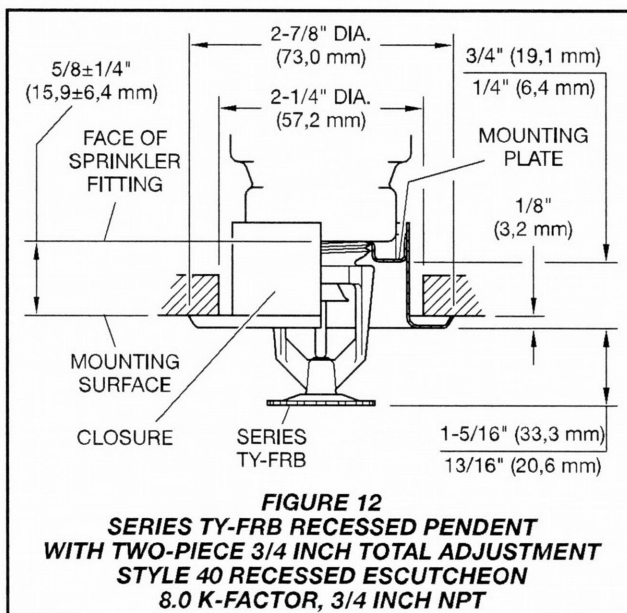
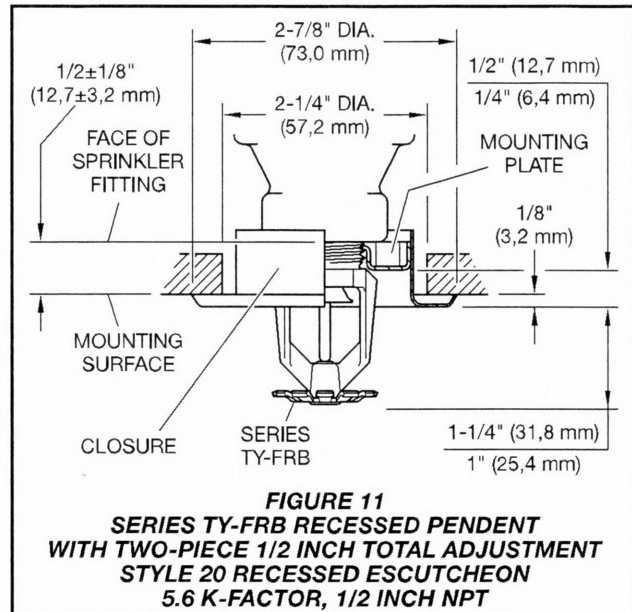
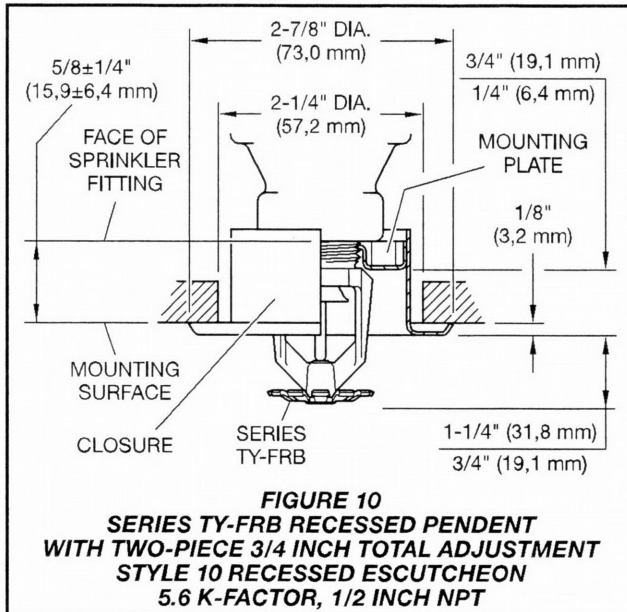

P/N 57 - XXX - X - XXX

		SIN			SPRINKLER FINISH			TEMPERATURE RATINGS
330	2.8K UPRIGHT (1/2"NPT)	TY1131		1	NATURAL BRASS		135	135°F (57°C)
331	2.8K PENDENT (1/2"NPT)	TY1231		3	PURE WHITE (RAL9010)*		155	155°F (68°C)
340	4.2K UPRIGHT (1/2"NPT)	TY2131		4	SIGNAL WHITE (RAL9003)		175	175°F (79°C)
341	4.2K PENDENT (1/2"NPT)	TY2231		5	JET BLACK (RAL9005)**		200	200°F (93°C)
370	5.6K UPRIGHT (1/2"NPT)	TY3131		7	LEAD COATED		286	286°F (141°C)
371	5.6K PENDENT (1/2"NPT)	TY3231		9	CHROME PLATED			
390	8.0K UPRIGHT (3/4"NPT)	TY4131						
391	8.0K PENDENT (3/4"NPT)	TY4231						
360	8.0K UPRIGHT (1/2"NPT)	TY4831*						
361	8.0K PENDENT (1/2"NPT)	TY4931*						

* Eastern Hemisphere sales only.
** Available in only 2.8K, 4.2K, and 8.0K, 155°F (68°C) and 200°F (93°C); requires lead time to manufacture.

TABLE D
SERIES TY-FRB PENDENT AND UPRIGHT SPRINKLERS
PART NUMBER SELECTION

Ordering Procedure

Contact your local distributor for availability. When placing an order, indicate the full product name and Part Number (P/N).

Sprinkler Assemblies with NPT

Thread Connections

Specify: Series TY-FRB (Specify SIN), (specify K-factor), (specify Pendent or Upright) Sprinkler (specify) temperature rating, (specify) finish or coating, P/N (specify from Table D)

Recessed Escutcheon:

Specify: Style (10, 20, 30, or 40) Recessed Escutcheon with (specify*) finish, P/N (specify*)

Sprinkler Wrench

Specify: W-Type 6 Sprinkler Wrench, P/N 56-000-6-387

Specify: W-Type 7 Sprinkler Wrench, P/N 56-850-4-001

* Refer to Technical Data Sheet TFP770

Series TY-L — 5.6 K-factor Horizontal Sidewall Sprinklers Standard Response, Standard Coverage

General Description

The Series TY-L, 5.6 K-factor, Horizontal Sidewall Sprinklers are standard response - standard coverage, solder type spray sprinklers designed for use in light and ordinary hazard, commercial occupancies such as banks, hotels, shopping malls, offices, etc. They are designed for installation along a wall or the side of a beam and just beneath a smooth ceiling. Horizontal sidewall sprinklers are commonly used instead of pendent or upright sprinklers due to aesthetics or building construction considerations where piping across the ceiling is not desirable.

Corrosion resistant coatings, where applicable, are utilized to extend the life of copper alloy sprinklers beyond that which would otherwise be obtained when exposed to corrosive atmospheres. Although corrosion resistant coated sprinklers have passed the standard corrosion tests of the applicable approval agencies, the testing is not representative of all possible corrosive atmospheres. Consequently, it is recommended that the end user be consulted with respect to the suitability of these coatings for any given corrosive environment. The effects of ambient temperature, concentration of chemicals, and gas/chemical velocity,

IMPORTANT

Always refer to Technical Data Sheet TFP700 for the "INSTALLER WARNING" that provides cautions with respect to handling and installation of sprinkler systems and components. Improper handling and installation can permanently damage a sprinkler system or its components and cause the sprinkler to fail to operate in a fire situation or cause it to operate prematurely.

should be considered, as a minimum, along with the corrosive nature of the chemical to which the sprinklers will be exposed.

WARNINGS

The Series TY-L Sprinklers described herein must be installed and maintained in compliance with this document, as well as with the applicable standards of the National Fire Protection Association, in addition to the standards of any other authorities having jurisdiction. Failure to do so may impair the performance of these devices.

The owner is responsible for maintaining their fire protection system and devices in proper operating condition. The installing contractor or sprinkler manufacturer should be contacted with any questions.

Model/Sprinkler Identification Numbers

TY3311 - HSW 5.6K, 1/2" NPT

TY3311 is a redesignation for S1803 and G3113.

Technical Data

Approvals

UL and C-UL Listed.
FM Approved.
(Refer to Table A for complete approval information.)

Maximum Working Pressure

175 psi (12,1 bar)

Discharge Coefficient

K = 5.6 GPM/psi^{1/2} (80,6 LPM/bar^{1/2})

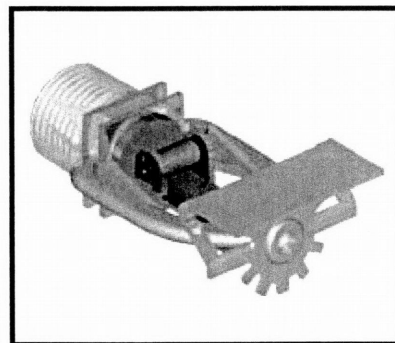

Temperature Ratings

Refer to Table A

Finishes

Sprinkler: Refer to Table A

Physical Characteristics

Frame	Brass
Sealing Button	Bronze w/Teflon†
Ejection Spring	Stainless Steel
Fusible Element	Solder, Copper
	Stainless Steel
Strut	Monel
Hook	Bronze/Monel
Deflector	Bronze

† DuPont Registered Trademark

Operation

A copper tube sealed by two stainless steel balls holds a fusible alloy. When the rated temperature is reached, the alloy melts, the balls are forced toward each other releasing the tension mechanism, allowing the sprinkler to operate.

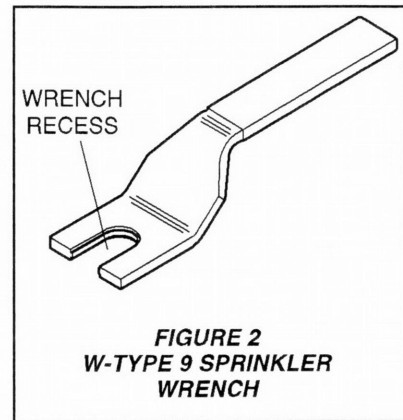
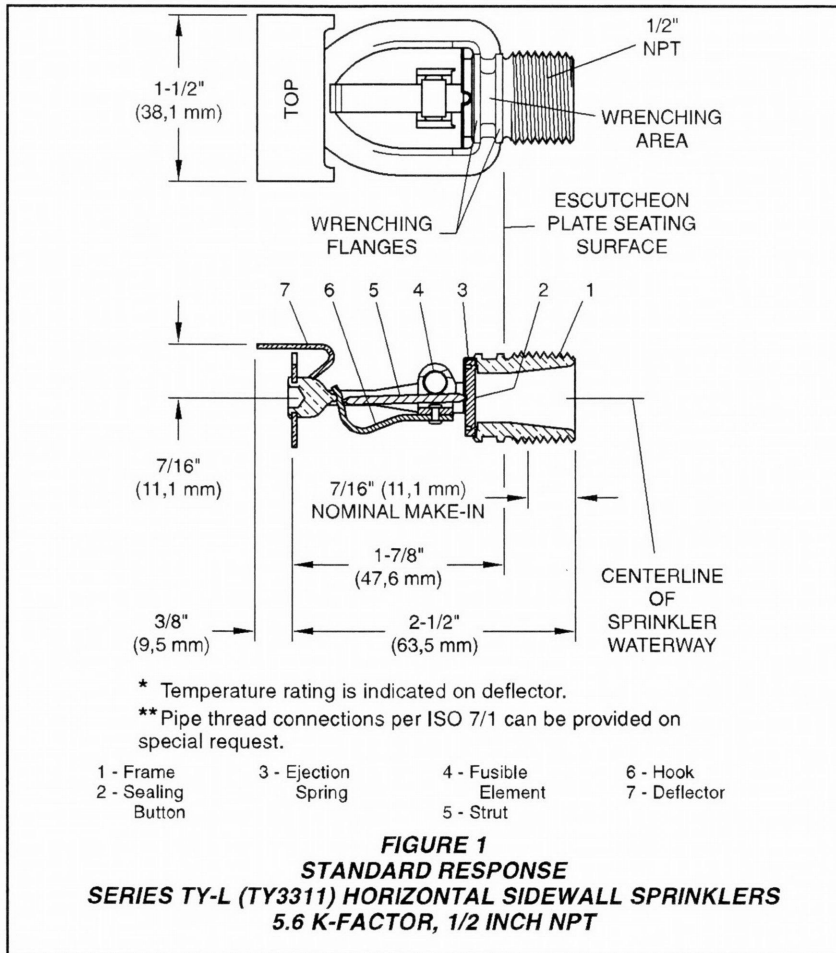

lel to the ceiling and perpendicular to the back wall surface. The word "TOP" on the deflector must face upwards toward the ceiling.

Step 2. After installing an escutcheon (as applicable) over the sprinkler pipe threads and with pipe thread sealant applied to the pipe threads, hand tighten the sprinkler into the sprinkler fitting.

Step 3. Tighten the sprinkler into the sprinkler fitting using only the W-Type 9 Sprinkler Wrench (Ref. Figure 2), except that an 8 or 10 inch adjustable Crescent wrench is to be used for wax coated sprinklers. With reference to Figure 1, the W-Type 9 Sprinkler Wrench is to be applied to the wrench area, or as applicable, the adjustable Crescent wrench is to be applied to the wrenching flanges.

When installing wax coated sprinklers with the adjustable Crescent wrench, additional care needs to be exercised to prevent damage to the wax coating on the sprinkler wrench flats or frame arms and, consequently, exposure of bare metal to the corrosive environment. The jaws of the wrench should be opened sufficiently wide to pass over the wrench flats without damaging the wax coating. Before wrench tightening the sprinkler, the jaws of the wrench are to be adjusted to just contact the sprinkler wrench flats. After wrench tightening the sprinkler, loosen the wrench jaws before removing the wrench.

After installation, the sprinkler wrench flats and frame arms must be inspected and the wax coating retouched (repaired) whenever the coating has been damaged and bare metal is exposed. The wax coating on the wrench flats can be retouched by gently applying a heated 1/8 inch diameter steel rod to the areas of wax that have

Design Criteria

The 5.6 K-factor, Series TY-L Horizontal Sidewall Sprinklers are intended for fire protection systems designed in accordance with the standard installation rules recognized by the applicable Listing or Approval agency (e.g., UL Listing is based on NFPA 13 requirements). The Series TY-L Horizontal Sidewall Sprinkler must be installed with a deflector to ceiling distance of 4 to 6 inches (100 to 150 mm). To meet this requirement the centerline of the sprinkler waterway must be located 4-5/16 to 6-5/16 inches (110 to 160 mm) below the ceiling. Installation of the Series TY-L Horizontal Sidewall Sprinklers in recessed escutcheons will void all manufacturer's warranties, as well as possibly void the sprinkler's Approvals and/or Listings.

Installation

The Series TY-L Sprinklers must be installed in accordance with the following instructions:

NOTES

A leak tight 1/2 inch NPT sprinkler joint should be obtained with a torque of 7 to 14 ft.lbs. (9,5 to 19,0 Nm). A maximum of 21 ft. lbs. (28,5 Nm) of torque may be used to install sprinklers with 1/2 NPT connections. Higher levels of torque may distort the sprinkler inlet and cause leakage or impairment of the sprinkler.

Do not attempt to make-up for insufficient adjustment in the escutcheon plate by under- or over-tightening the sprinkler. Readjust the position of the sprinkler fitting to suit.

The **Series TY-L Horizontal Sidewall Sprinklers** must be installed in accordance with the following instructions.

Step 1. The Series TY-L Horizontal Sidewall Sprinklers must be installed with their centerline of waterway paral-

K	TYPE	TEMP. RATING	FRAME COLOR CODE	SPRINKLER FINISH				
				NATURAL BRASS	CHROME PLATED	LEAD COATED	WAX COATED	WAX OVER LEAD COATED
5.6 1/2" NPT	HORIZONTAL SIDEWALL (TY3311)	165°F/74°C	Unpainted	1, 2, 3			1, 2	N/A
		212°F/100°C	White					
		280°F/138°C	Blue					

NOTES:

- Listed by Underwriters Laboratories, Inc. (UL) for Light or Ordinary Hazard Occupancies.
 - Listed by Underwriters Laboratories, Inc. for use in Canada (C-UL) for Light or Ordinary Hazard Occupancies.
 - Approved by Factory Mutual Research Corporation (FM) for Light Hazard Occupancies.
- N/A: Not Available.

TABLE A
LABORATORY LISTINGS AND APPROVALS

been damaged, to smooth it back over areas where bare metal is exposed.

NOTES

Only retouching of the wax coating applied to the wrench flats and frame arms is permitted, and the retouching is to be performed only at the time of the initial sprinkler installation.

The steel rod should be heated only to the point at which it can begin to melt the wax, and appropriate precautions need to be taken, when handling the heated rod, in order to prevent the installer from being burned.

If attempts to retouch the wax coating with complete coverage are unsuccessful, additional wax can be ordered in the form of a wax stick (the end of which is color coded). Only the correct color coded wax is to be used, and retouching of wrench flats and frame arms is only permitted at the time of initial sprinkler installation. With the steel rod heated as previously described, touch the rod to the area requiring additional wax with the rod angled downward, and then touch the wax stick to the rod approximately one-half inch away from the area requiring retouching. The wax will melt and run down onto the sprinkler.

Care and Maintenance

The Series TY-L Sprinklers must be maintained and serviced in accordance with the following instructions:

NOTES

Before closing a fire protection system main control valve for maintenance work on the fire protection system that it controls, permission to shut down the affected fire protection system must be

obtained from the proper authorities and all personnel who may be affected by this action must be notified.

Absence of an escutcheon, which is used to cover a clearance hole, may delay the time to sprinkler operation in a fire situation.

Sprinklers that are found to be leaking or exhibiting visible signs of corrosion must be replaced.

Automatic sprinklers must never be painted, plated, coated or otherwise altered after leaving the factory. Modified or over-heated sprinklers must be replaced.

Care must be exercised to avoid damage to the sprinklers - before, during, and after installation. Sprinklers damaged by dropping, striking, wrench twist/slippage, or the like, must be replaced.

Frequent visual inspections are recommended to be initially performed for corrosion resistant coated sprinklers, after the installation has been completed, to verify the integrity of the corrosion resistant coating. Thereafter, annual inspections per NFPA 25 should suffice; however, instead of inspecting from the floor level, a random sampling of close-up visual inspections should be made, so as to better determine the exact sprinkler condition and the long term integrity of the corrosion resistant coating, as it may be affected by the corrosive conditions present.

The owner is responsible for the inspection, testing, and maintenance of their fire protection system and devices in compliance with this document, as well as with the applicable standards of the National Fire Protection Association (e.g., NFPA 25), in addition to the standards of any other

authorities having jurisdiction. The installing contractor or sprinkler manufacturer should be contacted relative to any questions.

It is recommended that automatic sprinkler systems be inspected, tested, and maintained by a qualified Inspection Service in accordance with local requirements and/or national codes.

Limited Warranty

Products manufactured by Tyco Fire Products are warranted solely to the original Buyer for ten (10) years against defects in material and workmanship when paid for and properly installed and maintained under normal use and service. This warranty will expire ten (10) years from date of shipment by Tyco Fire Products. No warranty is given for products or components manufactured by companies not affiliated by ownership with Tyco Fire Products or for products and components which have been subject to misuse, improper installation, corrosion, or which have not been installed, maintained, modified or repaired in accordance with applicable Standards of the National Fire Protection Association, and/or the standards of any other Authorities Having Jurisdiction. Materials found by Tyco Fire Products to be defective shall be either repaired or replaced, at Tyco Fire Products' sole option. Tyco Fire Products neither assumes, nor authorizes any person to assume for it, any other obligation in connection with the sale of products or parts of products. Tyco Fire Products shall not be responsible for sprinkler system design errors or inaccurate or

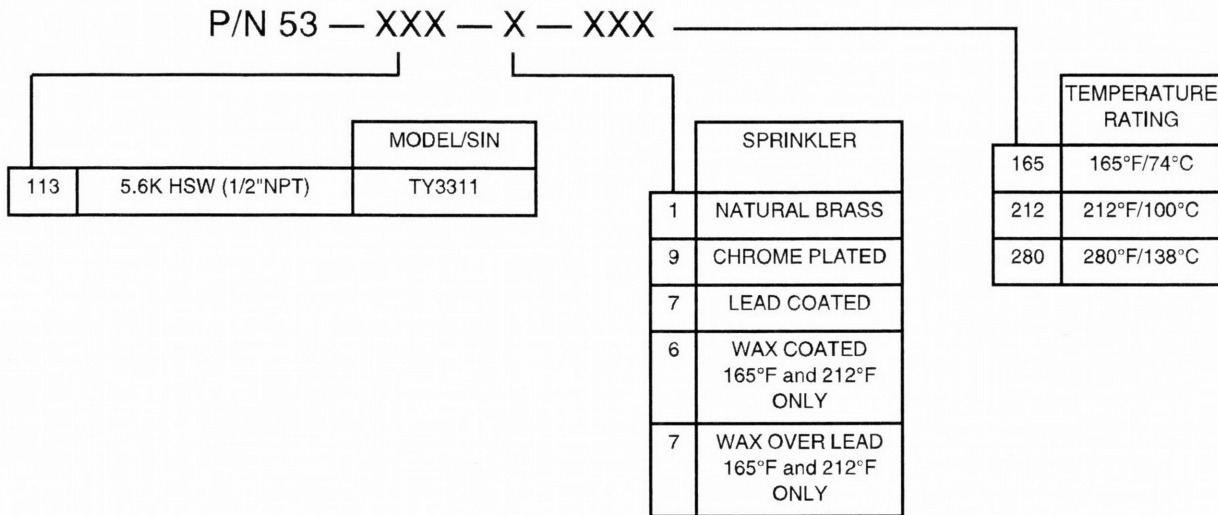

TABLE B
PART NUMBER SELECTION
SERIES TY-L HORIZONTAL SIDEWALL SPRINKLERS

incomplete information supplied by Buyer or Buyer's representatives.

IN NO EVENT SHALL TYCO FIRE PRODUCTS BE LIABLE, IN CONTRACT, TORT, STRICT LIABILITY OR UNDER ANY OTHER LEGAL THEORY, FOR INCIDENTAL, INDIRECT, SPECIAL OR CONSEQUENTIAL DAMAGES, INCLUDING BUT NOT LIMITED TO LABOR CHARGES, REGARDLESS OF WHETHER TYCO FIRE PRODUCTS WAS INFORMED ABOUT THE POSSIBILITY OF SUCH DAMAGES, AND IN NO EVENT SHALL TYCO FIRE PRODUCTS' LIABILITY EXCEED AN AMOUNT EQUAL TO THE SALES PRICE.

THE FOREGOING WARRANTY IS MADE IN LIEU OF ANY AND ALL OTHER WARRANTIES EXPRESS OR IMPLIED, INCLUDING WARRANTIES OF MERCHANTABILITY AND FITNESS FOR A PARTICULAR PURPOSE.

Ordering Procedure

When placing an order, indicate the full product name. Refer to the Price List for complete listing of Part Numbers.

Contact your local distributor for availability.

Sprinkler Assemblies with NPT Thread Connections:

Specify: (Specify Model/SIN), Standard Response, (specify K-factor), (specify temperature rating), Series TY-L Horizontal Sidewall Sprinkler with (specify type of finish), P/N (specify from Table B).

Sprinkler Wrench:

Specify: W-Type 9 Sprinkler Wrench, P/N 56-000-1-849.

Wax Sticks: (for retouching wrench damaged wax coating)

Specify: (Specify color) color coded Wax Stick for retouching (specify temperature rating) temperature rated Series TY-L Sprinklers, P/N (specify).

Red for 165°F P/N 56-065-1-155
Blue for 212°F and
280°F P/N 56-065-1-286

NOTES

Each wax stick is suitable for retouching up to twenty-five sprinklers.

The wax used for 280°F sprinklers is the same as for 212°F sprinklers, and, therefore, the 280°F sprinkler is limited to the same maximum ceiling temperature as the 212°F sprinkler (i.e., 150°F).

Dyna-Flow[®] – M-COAT[®]

Submittal Data Sheet

High Strength Steel Pipe

Dyna-Flow[®] – M-Coat[®] pipe is the “original” high-strength lightwall sprinkler pipe. Dyna-Flow – M-Coat has outstanding hydraulic capabilities and is recognized as the most popular alternative to Schedule-10 pipe. Lightweight, easy to cut and easy to handle for installation. Dyna-Flow – M-Coat is a valuable addition to any fire protection system.

Additional Benefits

Lightweight and easy to install, resulting in more efficient use of your freight and labor dollars. Provides stability needed to comply with standard hanger spacing (15 ft O.C.) per NFPA. Available in standard lengths for your convenience, or can be ordered in custom lengths upon approval. Fast cutting and welding, as well as easy roll grooving and end preparation. Available in Factory roll grooved form for quicker shop turnaround. Clean, durable mill coating provides longer “shelf life” and acts as an excellent primer for custom paint applications.

Superior Hydraulics

With an inside diameter of up to 11% larger than Schedule 40 and up to 7% larger than Schedule 10, Dyna-Flow – M-Coat pipe hydraulics are exceptional. Larger I.D.s enable Dyna-Flow – M-Coat, and related components, to be down-sized within the system, thus increasing the potential for job cost savings. For complete Hazen-Williams charts, refer to “Dyna-Flow Hydraulic Data Tables.”

Coatings & Fabrication

Dyna-Flow – M-Coat products are coated externally with an environmentally approved and specially formulated modified-acrylic or water-based coating. This durable, exterior black coating is paintable and acts as an excellent primer that is resistant to weathering and U.V. degradation from outdoor storage. Metallurgical properties provide excellent fabrication characteristics for end prep finishes, welding and roll grooving. No special process or equipment is needed for fabrication and installation.

The internal surface of all black Fire Sprinkler pipe up to 4.5000” in diameter shall be coated with Allied Tube & Conduit’s “M-Coat” ID Coating.

American Made

Manufactured at one of 3 U.S. Facilities and is available through distributors in the USA, Canada, Mexico, and Latin America.

Dyna-Flow – M-COAT Specifications				
NPS	Nominal I.D.	Wt.	Wt. (H2O Filled)	CRR
In; mm	In; mm	Lbs/Ft; kg/m	Lbs/Ft; kg/m	Unthreaded
1”	1.191	0.830	1.31	2.41
25	30.3	1.2	1.95	–
1¼”	1.536	1.059	1.87	1.55
32	39.0	1.6	2.78	–
1½”	1.728	1.667	2.71	3.44
40	43.9	2.5	4.03	–
2”	2.203	2.104	3.79	2.78
50	56.0	3.1	5.64	–
2½”	2.703	2.564	5.10	1.60
65	68.7	3.8	7.59	–
3”	3.314	3.387	7.18	1.48
75	84.2	5.0	10.69	–
4”	4.310	4.473	10.86	1.00



Specifications & Approvals

Dyna-Flow – M-Coat pipe is manufactured to meet ASTM A 795, Type E Grade A, and are in compliance with NFPA-13 and NFPA-14. All sizes of Dyna Flow are UL Listed, FM Approved and ULC Listed.

Dyna-Flow – M-Coat is UL/ULC Listed for use with roll grooved, plain-end couplings, and welded joints for wet, dry, pre-action and deluge systems. It is FM Approved for roll grooved, plain-ended, and welded joints for wet systems. Refer to appropriate documentation for up-to-date listing and approval information.

Project:	Sprinkler Contractor:	Date:
Engineer:	Specification Reference:	System Type:
Locations:	Comments:	



Customer Service: (800) 882-5543 Fax: (800) 659-7730

www.alliedtube-sprinkler.com

• 16100 S Lathrop Ave
Harvey, IL 60426

• 11350 Norcom Rd.
Philadelphia, PA 19154

• 2525 N 27th Ave.
Phoenix, AZ 85009

FireLock EZ® Rigid Coupling

Style 009N



PATENTED

Approvals/Listings:



See Victaulic Publication 10.01 for more details.

Product Description:

The FireLock EZ Style 009N Installation-Ready™ Rigid Coupling is for use in the fire protection market. The coupling's unique design eliminates loose parts, promotes consistent installation and provides substantial gains in productivity.

IMPORTANT

FireLock EZ Style 009N couplings are recommended for use ONLY on fire protection systems.

Material Specifications:

Housing:

Ductile iron conforming to ASTM A-536, grade 65-45-12. Ductile iron conforming to ASTM A-395, grade 65-45-15, is available upon special request.

Housing Coating:

- Orange enamel (North America, Asia Pacific)
- Red enamel (Europe)
- Optional: Hot dipped galvanized

Gasket:

Grade "E" EPDM (Type A)

FireLock EZ products have been Listed by Underwriters Laboratories Inc., Underwriters Laboratories of Canada Limited, and Approved by Factory Mutual Research for wet and dry (oil free air) sprinkler services within the rated working pressure.

Bolts/Nuts:

Zinc electroplated carbon steel, trackhead meeting the physical and chemical requirements of ASTM A-449 and physical requirements of ASTM A-183.

Job/Owner

System No.	
Location	

Contractor

Submitted By	
Date	

Engineer

Spec Section	
Paragraph	
Approved	
Date	



Listings/Approvals ¹

The information provided below is based on the latest listing and approval data at the time of publication. Listings/Approvals are subject to change and/or additions by the approvals agencies. Contact Victaulic for performance on other pipe and the latest listings and approvals.

Nominal Size	cULus			FM			Vds	LPCB
	Sch. 5 psi kPa	Sch. 10 psi kPa	Sch. 40 psi kPa	Sch. 5 psi kPa	Sch. 10 psi kPa	Sch. 40 psi kPa		
1 ¼ 32	232 1600	365 2517	365 2517	175 1205	363 2502	363 2502	365 2517	365 2517
1 ½ 40	232 1600	365 2517	365 2517	175 1205	363 2502	363 2502	365 2517	365 2517
2 50	363 2502	365 2517	365 2517	175 1205	363 2502	363 2502	365 2517	365 2517
2 ½ 65	N/A	365 2517	365 2517	175 1205	363 2502	363 2502	365 2517	365 2517
76.1 mm	N/A	365 ² 2517	N/A	N/A	363 ³ 2502	N/A	365 2517	365 2517
3 80	N/A	365 2517	365 2517	175 1205	363 2502	363 2502	365 2517	365 2517
4 100	N/A	365 2517	365 2517	175 1205	363 2502	363 2502	365 2517	365 2517
108.0 mm	N/A	N/A	N/A	N/A	363 2502	363 2502	N/A	N/A
5 125	N/A	290 2000	365 2517	N/A	363 2502	363 2502	N/A	N/A
133.0 mm	Refer to Submittal 10.61							
139.7 mm	Refer to Submittal 10.61							
165.1 mm	Refer to Submittal 10.61							
6 150	N/A	290 2000	365 2517	N/A	363 2502	363 2502	N/A	N/A
8 200	N/A	290 2000	365 2517	N/A	363 2502	363 2502	N/A	N/A

1 Listed/Approved for wet and dry pipe systems (> -40°F/-40°C) for continuous use in freezing conditions, use of silicone gaskets is recommended. Please refer to the Victaulic Installation Manual (I-009N/009H) for details concerning when supplemental lubrication is required.

2 cULus listed for DIN 2458 2.6 mm pipe wall.

3 FM approved for BS 1387 Medium 3.6 mm pipe wall.

Speciality Pipe

Pipe	Size	Pressure Rating		Pipe	Size	Pressure Rating		Pipe	Size	Pressure Rating	
		cULus psi kPa	FM psi kPa			cULus psi kPa	FM psi kPa			cULus psi kPa	FM psi kPa
BLT	1 ¼ – 2	300 2068	365 2517	EZT	1 ¼ – 2	300 2068	365 2517	MT	1 ¼ – 2	300 2068	365 2517
DF	1 ¼ – 4	300 2068	365 2517	FF	1 ¼ – 4	300 2068	365 2517	MLT	1 ¼ – 2	N/A	365 2517
DT	1 ¼ – 2	300 2068	365 2517	FLF	1 ¼ – 4	N/A	365 2517	ST	1 ¼ – 2	N/A	365 2517
EF	1 ¼ – 4	175 1206	175 1206	FLT	1 ¼ – 2	N/A	365 2517	STF	1 ¼ – 4	N/A	365 2517
EL	1 ¼ – 2	300 2068	365 2517	FLTL	1 ¼ – 2	N/A	365 2517	TF	2 ¼ – 4	N/A	365 2517
ET40	1 ¼ – 2	300 2068	365 2517	GL	1 ¼ – 2	300 2068	365 2517	WLS	1 ¼ – 2	300 2068	365 2517
EZF	3 – 4	300 2068	365 2517	MF	1 ¼ – 4	300 2068	365 2517	WST	1 ¼ – 2	N/A	365 2517
								XL	1 ¼ – 2	300 2068	365 2517

Style 009N Dimensions:

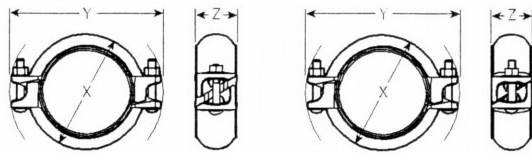

Style 009N Pre-Assembled
(Push On Condition)

Style 009N Joint Assembled

Nominal Size	Actual Outside Diameter	Maximum Working Pressure ¹	Maximum End Load ¹	Allow. Pipe End Separation ²	Bolt/Nut ³	Dimensions					Approx. Weight Each
						Pre-assembled (Push On Condition)		Joint Assembled			
						X	Y	X	Y	Z	
1 1/4 32	1.660 42.4	365 2517	790 3514	0.10 2.54	2 - 3/8 x 2 M - 10 x 2	3.10 79	4.90 124	2.70 69	4.90 124	1.92 49	1.4 0.7
1 1/2 40	1.900 48.3	365 2517	1035 4604	0.10 2.54	2 - 3/8 x 2 M - 10 x 2	3.30 84	5.10 129	3.00 76	5.10 129	1.92 49	1.5 0.7
2 50	2.375 60.3	365 2517	1616 7193	0.12 3.05	2 - 3/8 x 2 M - 10 x 2	3.90 99	5.60 142	3.50 89	5.60 142	1.95 50	1.9 0.9
2 1/2 65	2.875 73.0	365 2517	2370 10542	0.12 3.05	2 - 3/8 x 2 1/2 M - 10 x 2 1/2	4.50 114	6.10 155	4.00 102	6.10 155	1.95 50	2.1 1.0
76.1 mm	3.000 76.1	365 2517	2580 11476	0.12 3.05	2 - 3/8 x 2 1/2 M - 10 x 2 1/2	4.56 115.7	6.00 152.5	4.05 102.8	6.06 153.9	1.94 49.2	2.1 1.0
3 80	3.500 88.9	365 2517	3512 15622	0.12 3.05	2 - 3/8 x 2 1/2 M - 10 x 2 1/2	5.10 129	6.70 170	4.60 117	6.70 170	1.95 50	2.3 1.0
4 100	4.500 114.3	365 2517	5805 25822	0.17 4.32	2 - 3/8 x 2 1/2 M - 10 x 2 1/2	5.95 151	7.80 199	5.54 141	7.47 190	2.14 55	2.9 1.3
108.0 mm	4.250 108.0	365 2517	5175 23020	0.17 4.318	2 - 3/8 x 2 1/2	5.56 141	7.39 1.88	5.28 134	7.36 187	2.14 54	3.1 1.4
5 125	5.563 141.3	365 2000	5178 23033	0.17 4.318	2 - 1/2 x 3	7.19 183	9.25 235	6.7 170	9.11 231	2.19 56	5.0 2.3
133.0 mm	Refer to Submittal 10.61										
139.7 mm	Refer to Submittal 10.61										
165.1 mm	Refer to Submittal 10.61										
6 150	6.625 168.3	365 2000	9997 44469	0.17 4.318	2 - 1/2 x 3 1/4	8.32 211	10.29 261	7.82 199	10.13 257	2.17 55	6.0 2.7
8 200	8.625 219.1	365 1620	13730 61074	0.17 4.318	2 - 3/8 x 4	10.89 277	13.31 338	10.22 260	13.1 333	2.5 64	11.4 5.2

- Working Pressure and End Load are total, from all internal and external loads, based on standard weight (ANSI) steel pipe, standard roll or cut grooved in accordance with Victaulic specifications. See page 1 of this document for Listed/Approved ratings on other pipe. WARNING: FOR ONE TIME FIELD TEST ONLY, the Maximum Joint Working Pressure may be increased to 1 1/2 times the figures shown in the chart on page 1, specific to pipe schedule and size.
- The allowable pipe separation dimension shown is for system layout purposes only. FireLock EZ couplings are considered rigid connections and will not accommodate expansion or contraction of the piping system.
- Number of bolts required equals number of housing segments.

General Notes:

NOTE: When assembling FireLock EZ couplings onto end caps, take additional care to make certain the end cap is fully seated against the gasket end stop. For FireLock EZ Style 009N couplings, use FireLock No. 006 end caps containing the "EZ" marking on the inside face or No. 60 end caps containing the "QV EZ" marking on the inside face. Non-Victaulic end cap products shall not be used with Style 009N couplings. IMPORTANT: Gaskets intended for the Style 009 or Style 009V couplings cannot be used with the Style 009N coupling. There is no interchanging of gaskets or housings between coupling styles.

Use Of Flushseal Gaskets For Dry Pipe Systems

NOTE: FireLock EZ couplings are supplied with FireLock EZ Grade "E" Type A gaskets. These gaskets include an integral pipe stop, that once installed provides the similar benefits as a FlushSeal gasket for dry pipe systems. It should be noted that standard Victaulic FlushSeal gaskets are not compatible and cannot be used with the FireLock EZ couplings.

Installation

Reference should always be made to the I-100 Victaulic Field Installation Handbook for the product you are installing. Handbooks are included with each shipment of Victaulic products for complete installation and assembly data, and are available in PDF format on our website at www.victaulic.com.

Warranty

Refer to the Warranty section of the current Price List or contact Victaulic for details.

Note

This product shall be manufactured by Victaulic or to Victaulic specifications. All products to be installed in accordance with current Victaulic installation/assembly instructions. Victaulic reserves the right to change product specifications, designs and standard equipment without notice and without incurring obligations.

Trademarks

Victaulic, FireLock EZ, and Installation-Ready are registered trademarks of Victaulic Company.

Victaulic® Grooved End Fittings

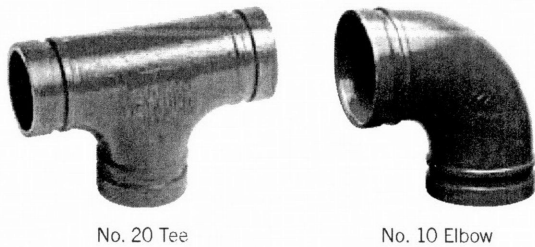

No. 20 Tee

No. 10 Elbow

Fittings are provided in various materials including ductile iron, steel or segmentally welded steel depending on styles and size. Fittings are painted orange enamel with a galvanized finish available as an option, contact Victaulic for details.

Victaulic fittings are designed specifically for use in grooved piping systems. Fittings are provided grooved or with shoulders conforming to standard steel pipe outside diameters. When connecting wafer or lug-type butterfly valves directly to Victaulic fittings with 741 or 743 Vic-Flange® adapters, check disc clearance dimensions with I.D. dimension of fitting.

Certifications/Listings



When supplied as "hot dip galvanized" the following fittings are UL Classified in accordance with ANSI/NSF 61 and for use on cold +86°F/+30°C potable water service and ANSI/NSF 372: No. 10 90° Elbow, No. 11 45° Elbow, No. 12 22 1/2° Elbow, No. 13 11 1/4° Elbow, No. 100 90° Long Radius Elbow, No. 110 45° Long Radius Elbow, No. 20 Tee, No. 25 Tee with Grooved Branch, No. 30 45° Lateral, No. 60 Cap, No. 50 Concentric Reducers, No. 51 Eccentric Reducers.

Note: The following Victaulic fittings are VdS approved: No.10 90° Elbow, No.11 45° Elbow, No.20 Tee and No.60 Cap.

Note: The following Victaulic fittings are LPCB approved: No.10 90° Elbow, No.11 45° Elbow, No.12 22 1/2° Elbow, No.13 11 1/4° Elbow, No.30 45° Lateral, No.30-R Reducing Lateral, No.100 Long Radius Elbow, No.110 Long Radius Elbow, No.20 Tee, No.35 Cross, No.60 Cap, No.25 Reducing Tee, No.33 True Wye, No.50 Concentric Reducer, No.51 Eccentric Reducer and No.29M Tee with Threaded Branch.

Product Description

Victaulic offers a broad line of fittings in sizes through 60"/1500mm in a variety of straight and reducing styles. Most standard fittings are cast of durable ductile iron to precise tolerances. Victaulic standard fittings pressure ratings conform to the ratings of Victaulic Style 77 couplings.

All fittings are supplied with grooves or shoulders to permit fast installation without field preparation. The grooved design permits flexibility for easy alignment. *These fittings are not intended for use with Victaulic couplings for plain end pipe (refer to publication 14.04 for fittings available for plain end applications).*

Job/Owner

System No.	
Location	

Contractor

Submitted By	
Date	

Engineer

Spec Section	
Paragraph	
Approved	
Date	



Material Specifications

Fitting: (specify choice)

Standard: Ductile iron conforming to ASTM A-536, Grade 65-45-12.

Optional: Segmentally welded steel as shown under nipples

Nipples: (specify choice)

$\frac{3}{4}$ – 4"/20 – 100 mm: Carbon steel, Schedule 40, conforming to ASTM A-53, Type F

5 – 6"/125 – 150 mm: Carbon steel, Schedule 40, conforming to ASTM A-53, Type E or S, Gr. B

8 – 12"/200 – 300 mm: Carbon steel, Schedule 30 or 40, conforming to ASTM A-53, Type E or S, Gr. B

Flanged Adapter Nipples: (specify choice)

Class 125 Flange: Cast iron conforming to ANSI B-16.1

Class 150 Flange: Carbon steel conforming to ANSI B-16.5, raised or flat face

Class 300 Flange: Carbon steel conforming to ANSI B-16.5, raised or flat face

Fitting Coating: (specify choice)

Standard: Orange enamel.

Optional: Hot dip galvanized and others. Some fittings supplied electroplated as standard – see product specifications.

Flanged Adapter Nipple Coating: (specify choice)

Standard: None (Unfinished)

Optional: Orange enamel, hot dip galvanized and others.

Flow Data

(Frictional Resistance)

The chart expresses the frictional resistance of various Victaulic fittings as equivalent feet of straight pipe. Fittings not listed can be estimated from the data given, for example, a 22½° elbow is approximately one-half the resistance of a 45° elbow. Values of mid-sizes can be interpolated.

Size		Dimensions					
Nominal Size inches mm	Actual Outside Diameter inches mm	90° Elbows		45° Elbows		Tees	
		No. 10 Std. Radius feet meters	No. 100 1 ½ D Long Radius feet meters	No. 11 Std. Radius feet meters	No. 110 1 ½ D Long Radius feet meters	Branch feet meters	Run feet meters
1	1.315	1.7	—	0.8	—	4.2	1.7
25	33.7	0.5	—	0.2	—	1.3	0.5
2	2.375	3.5	2.5	1.8	1.1	8.5	3.5
50	60.3	1.1	0.8	0.5	0.3	2.6	1.1
76.1 mm	3.000	4.3	—	2.1	—	10.8	4.3
	76.1	1.3	—	0.7	—	3.3	1.3
3	3.500	5.0	3.8	2.6	1.6	13.0	5.0
80	88.9	1.5	1.2	0.8	0.5	4.0	1.5
108.0 mm	4.250	6.4	—	3.2	—	15.3	6.4
	108.0	2.0	—	0.9	—	4.7	2.0
4	4.500	6.8	5.0	3.4	2.1	16.0	6.8
100	114.3	2.1	1.5	1.0	0.6	4.9	2.1
133.0 mm	5.250	8.1	—	4.1	—	20.0	8.1
	133.0	2.5	—	1.2	—	6.2	2.5
139.7 mm	5.500	8.5	—	4.2	—	21.0	8.5
	139.7	2.6	—	1.3	—	6.4	2.6
5	5.563	8.5	—	4.2	—	21.0	8.5
125	141.3	2.6	—	1.3	—	6.4	2.6
159.0 mm	6.250	9.4	—	4.9	—	25.0	9.6
	159.0	2.9	—	1.5	—	7.6	2.9
165.1 mm	6.500	9.6	—	5.0	—	25.0	10.0
	165.1	2.9	—	1.5	—	7.6	3.0
6	6.625	10.0	7.5	5.0	3.0	25.0	10.0
150	168.3	3.0	2.3	1.5	0.9	7.6	3.0
8	8.625	13.0	9.8	6.5	4.0	33.0	13.0
200	219.1	4.0	3.0	2.0	1.2	10.1	4.0
10	10.750	17.0	12.0	8.3	5.0	41.0	17.0
250	273.0	5.2	3.7	2.5	1.5	12.5	5.2
12	12.750	20.0	14.5	10.0	6.0	50.0	20.0
300	323.9	6.1	4.4	3.0	1.8	15.2	6.1
14	14.000	24.5 ¹	15.8	18.5 ¹	11.0	70.0	23.0
350	355.6	7.5	4.8	5.6	3.4	21.3	7.0
16	16.000	28.0 ¹	18.0	21.0 ¹	13.0	80.0	27.0
400	406.4	8.5	5.5	6.4	4.0	24.4	8.2
18	18.000	31.0 ¹	20.0	23.5 ¹	14.0	90.0	30.0
450	457.0	9.5	6.1	7.2	4.3	27.4	9.1
20	20.000	34.0 ¹	22.5	25.5 ¹	16.0	100.0	33.0
800	508.0	10.4	6.9	7.8	4.9	30.5	10.1
24	24.000	42.0 ¹	27.0	29.5 ¹	19.0	120.0	40.0
600	610.0	12.8	8.2	9.0	5.8	36.6	12.2

AGS fittings available up to 60"/1500 mm. Contact Victaulic for details.



¹ Fitting flow data for 14-24"/350-600 mm size No. 10 and No. 11 Elbows is based on fittings for Style 07 and 77 couplings. For flow data on AGS fittings (No. W10 and No. W11 Elbows), refer to publication 20.05.

Dimensions

Elbows

No. 10 90° Elbow

No. 11 45° Elbow

No. 12 22 ½° Elbow

No. 13 11 ¼° Elbow

No. 100 90° Long Radius Elbow

No. 101 90° Long Radius Elbow

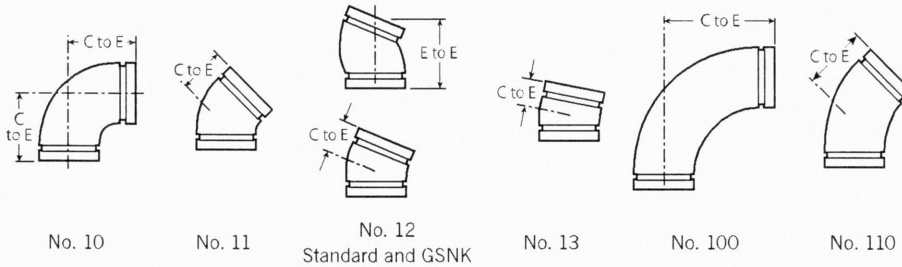

Size		No. 10 90° Elbow		No. 11 45° Elbow		No. 12 22½° Elbow		No. 13 11¼° Elbow		No. 100 90° Long Radius Elbow		No. 110 45° Long Radius Elbow	
Nominal Size	Actual Outside Diameter	C to E	Approx. Wgt. Each	C to E	Approx. Wgt. Each	C to E	Approx. Wgt. Each	C to E	Approx. Wgt. Each	C to E	Approx. Wgt. Each	C to E	Approx. Wgt. Each
inches	inches	inches	lbs.	inches	lbs.	inches	lbs.	inches	lbs.	inches	lbs.	inches	lbs.
mm	mm	mm	kg	mm	kg	mm	kg	mm	kg	mm	kg	mm	kg
¾	1.050	2.25	0.5	1.50	0.5	1.63 (sw)	—	1.38 (sw)	—	2.50 (sw)	0.4	1.88 (sw)	0.3
20	26.9	57	0.2	38	0.2	41	—	35	—	64	0.2	48	0.1
1	1.315	2.25	0.6	1.75	0.6	3.25 ²	0.6	1.38 (sw)	0.3	2.88 (sw)	0.6	2.25 (sw)	0.5
25	33.7	57	0.3	44	0.3	83	0.3	35	0.1	73	0.3	57	0.2
1 ¼	1.660	2.75	1.0	1.75	0.9	1.75	0.8	1.38 (sw)	0.5	3.25 (sw)	1.1	2.38 (sw)	0.7
32	42.4	70	0.5	44	0.4	44	0.4	35	0.2	83	0.5	60	0.3
1 ½	1.900	2.75	1.2	1.75	0.9	1.75	0.8	1.38 (sw)	0.5	3.63 (sw)	2.2	2.50 (sw)	1.3
40	48.3	70	0.5	44	0.4	44	0.4	35	0.2	92	1.0	64	0.6
2	2.375	3.25	1.8	2.00	1.3	3.75 ²	1.4	1.38	1.0	4.38	2.5	2.75	1.8
50	60.3	83	0.8	51	0.6	95	0.6	35	0.5	111	1.1	70	0.8
2 ½	2.875	3.75	3.2	2.25	2.2	4.00 ²	2.3	1.50	1.1	5.13	3.4	3.00	2.8
65	73.0	95	1.5	57	1.0	102	1.0	38	0.5	130	1.5	76	1.3
76.1 mm	3.000	3.75	3.7	2.25	3.4	2.25	—	1.50	—	—	—	—	—
	76.1	95	1.7	57	1.5	57	—	38	—	—	—	—	—
3	3.500	4.25	4.5	2.50	3.1	4.50 ²	3.1	1.50	2.1	5.88	6.0	3.38	4.9
80	88.9	108	2.0	64	1.4	114	1.4	38	1.0	149	2.7	86	2.2
3 ½	4.000	4.50	5.6	2.75	4.3	2.50 (sw)	4.0	1.75 (sw)	2.7	—	—	—	—
90	101.6	114	2.5	70	2.0	64	1.8	44	1.2	—	—	—	—
4	4.500	5.00	7.1	3.00	5.6	2.88	5.6	1.75	3.6	7.50	12.3	4.00	7.3
100	114.3	127	3.2	76	2.5	73	2.5	44	1.6	191	5.6	102	3.3
108.0 mm	4.250	5.00	11.0	3.00	5.6	—	—	—	—	—	—	—	—
	108.0	127	5.0	76	2.5	—	—	—	—	—	—	—	—
4 ½	5.000	5.25 (sw)	10.0	3.13 (sw)	6.0	3.50 (sw)	6.6	1.88 (sw)	4.2	—	—	—	—
120	127.0	133	4.5	79	2.7	89	3.0	48	1.9	—	—	—	—
5	5.563	5.50	11.7	3.25	8.3	2.88 (sw)	7.8	2.00 (sw)	5.0	9.25 (sw)	18.0	4.88 (sw)	14.8
125	141.3	140	5.3	83	3.8	73	3.5	51	2.2	235	8.2	124	6.7
133.0 mm	5.250	5.50	11.7	3.25	8.3	—	—	—	—	—	—	—	—
	133.0	140	5.3	83	3.8	—	—	—	—	—	—	—	—
139.7 mm	5.500	5.50	11.7	3.25	8.3	2.88	—	2.00	—	—	—	—	—
	139.7	140	5.3	83	3.8	73	—	51	—	—	—	—	—
6	6.625	6.50	17.2	3.50	10.8	6.25 ²	12.2	2.00	7.0	10.75	30.4	5.50	17.4
150	168.3	165	7.8	89	4.9	159	5.5	51	3.2	273	13.8	140	7.9

2 Gooseneck design, end-to-end dimension fittings in this size, contact your nearest Victaulic sales representative.

3 For 14/350 mm and larger roll grooved systems, Victaulic offers the Advanced Groove System (AGS). For pricing and availability of cut groove fittings in this size, contact your nearest Victaulic sales representative.

4 Chinese standard sizes

Tees, Crosses and True Wyes

No. 20 Tee

No. 35 Cross

No. 33 True Wye

No. 29M Tee with Threaded Branch

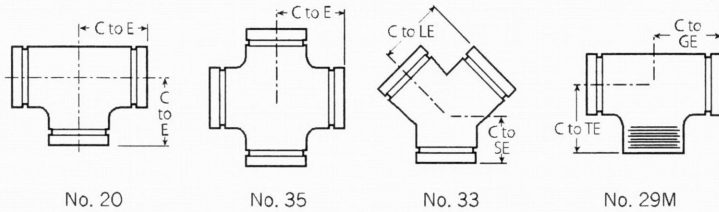

Size		No. 20 Tee			No. 35 Cross (sw)		No. 33 True Wye (sw)			No. 29M Tee with Threaded Branch		
Nominal Size	Actual Outside Diameter	C to E	Approx. Weight Each	C to E	Approx. Weight Each	C to LE	C to SE	Approx. Weight Each	C to GE	C to TE	Approx. Weight Each	
inches mm	inches mm	inches mm	lbs. kg	inches mm	lbs. kg	inches mm	inches mm	lbs. kg	inches mm	inches mm	lbs. kg	
3/4 20	1.050 26.9	2.25 57	0.6 0.3	2.25 57	0.9 0.4	2.25 57	2.00 51	0.7 0.3	2.25 57	2.25 (sw) 57	0.6 0.3	
1 25	1.315 33.7	2.25 57	1.0 0.5	2.25 57	1.3 0.6	2.25 57	2.25 57	1.1 0.5	2.25 57	2.25 57	1.0 0.5	
1 1/4 32	1.660 42.4	2.75 70	1.5 0.7	2.75 70	2.1 1.0	2.75 70	2.50 64	1.5 0.7	2.75 70	2.75 70	1.5 0.7	
1 1/2 40	1.900 48.3	2.75 70	2.0 0.9	2.75 70	2.5 1.1	2.75 70	2.75 70	1.8 0.8	2.75 70	2.75 70	2.0 0.9	
2 50	2.375 60.3	3.25 83	3.0 1.4	3.25 83	3.8 1.7	3.25 83	2.75 70	2.5 1.1	3.25 83	4.25 108	3.0 1.4	
2 1/2 65	2.875 73.0	3.75 95	4.3 2.0	3.75 95	6.1 2.8	3.75 95	3.00 76	4.3 2.0	3.75 95	3.75 95	4.3 2.0	
76.1 mm	3.000 76.1	3.75 95	5.2 2.4	—	—	—	—	—	3.75 95	3.75 (sw) 95	5.2 2.4	
3 80	3.500 88.9	4.25 108	6.8 3.0	4.25 108	10.5 4.8	4.25 108	3.25 83	6.1 2.8	4.25 108	6.00 152	6.8 3.1	
3 1/2 90	4.000 101.6	4.50 (sw) 114	7.9 3.6	4.50 114	11.5 5.2	4.50 114	3.50 89	9.6 4.4	4.50 114	4.50 (sw) 114	7.9 3.6	
108.0 mm	4.250 108.0	5.00 127	15.5 7.0	—	—	—	—	—	5.00 127	5.00 (sw) 127	15.5 7.0	
4 100	4.500 114.3	5.00 127	11.9 5.4	5.00 127	15.8 7.2	5.00 127	3.75 95	9.8 4.4	5.00 127	7.25 184	11.9 5.4	
4 1/2 120	5.000 127.0	5.25 (sw) 133	15.0 6.8	5.25 133	18.5 8.4	—	—	—	5.25 133	5.25 (sw) 133	15.0 6.8	
133.0 mm	5.250 133.0	5.50 140	17.8 8.1	—	—	—	—	—	5.50 140	5.50 (sw) 140	17.8 8.1	
139.7 mm	5.500 139.7	5.50 140	17.8 8.1	—	—	—	—	—	5.50 140	5.50 (sw) 140	17.8 8.1	
5 125	5.563 141.3	5.50 140	17.8 8.1	5.50 140	20.0 9.1	5.50 140	4.00 102	15.0 6.8	5.50 140	5.50 (sw) 140	17.8 8.1	
159.0 mm	6.250 159.0	6.50 165	27.1 12.3	—	—	—	—	—	6.50 165	6.50 (sw) 165	27.1 12.3	
165.1 mm	6.500 165.1	6.50 165	22.0 10.0	6.50 165	28.0 12.7	—	—	—	6.50 165	6.50 (sw) 165	22.0 10.0	

6 For 14/350 mm and larger roll grooved systems, Victaulic offers the Advanced Groove System (AGS). For pricing and availability of cut groove fittings in this size, contact your nearest Victaulic sales representative.

7 Chinese standard sizes

Reducing Tee

No. 25 Grooved Branch

No. 29T Threaded Branch

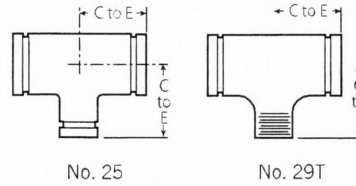
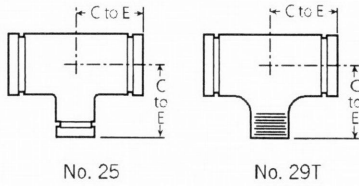

Size			No. 25 Std.	No. 29T w/ Thd. Branch	Approx. Weight Each		
Nominal Size inches mm			C to E inches mm	C to E inches mm	lbs. kg		
1 25	x	1 25	x	3/4 20	2.25 (sw) 57	2.25 (sw) 57	1.0 0.5
					2.75 (sw) 70	2.75 (sw) 70	1.3 0.6
					2.75 (sw) 70	2.75 (sw) 70	1.5 0.7
1 1/2 40	x	1 1/2 40	x	3/4 20	2.75 (sw) 70	2.75 (sw) 70	1.5 0.7
					2.75 (sw) 70	2.75 (sw) 70	1.5 0.7
					2.75 (sw) 70	2.75 (sw) 70	1.5 0.7
2 50	x	2 50	x	3/4 20	3.25 (sw) 83	3.25 (sw) 83	2.5 1.1
					3.25 (sw) 83	3.25 (sw) 83	2.7 1.2
					3.25 (sw) 83	3.25 (sw) 83	1.8 0.8
2 1/2 65	x	2 1/2 65	x	3/4 20	3.75 (sw) 95	3.75 (sw) 95	3.9 1.8
					3.75 (sw) 95	3.75 (sw) 95	3.8 1.7
					3.75 (sw) 95	3.75 (sw) 95	4.2 1.9
3 80	x	3 80	x	3/4 20	4.25 (sw) 108	4.25 (sw) 108	5.7 2.6
					4.25 (sw) 108	4.25 (sw) 108	6.1 2.8
					4.25 (sw) 108	4.25 (sw) 108	8.0 3.6
3 80	x	3 80	x	1 1/4 32	4.25 (sw) 108	4.25 (sw) 108	6.5 2.9
					4.25 (sw) 108	4.25 (sw) 108	6.2 2.8
					4.25 (sw) 108	4.25 (sw) 108	6.4 2.9

8 For 14/350 mm and larger roll grooved systems, Victaulic offers the Advanced Groove System (AGS). For pricing and availability of cut groove fittings in this size, contact your nearest Victaulic sales representative.

9 Cast fitting available. Contact Victaulic for details.

Size			No. 25 Std.	No. 29T w/ Thd. Branch	Approx. Weight Each						
Nominal Size inches mm			C to E inches mm	C to E inches mm	lbs. kg						
4 100	x	4 100	x	3/4 20	5.00 (sw) 127	5.00 (sw) 127	8.0 3.6				
				1 25	5.00 (sw) 127	5.00 (sw) 127	7.8 3.5				
				1 1/4 32	5.00 (sw) 127	5.00 (sw) 127	9.6 4.4				
				1 1/2 40	5.00 (sw) 127	5.00 (sw) 127	10.2 4.6				
				2 50	5.00 (sw) 127	5.00 (sw) 127	11.2 5.1				
				2 1/2 65	5.00 (sw) 127	5.00 (sw) 127	11.4 5.2				
				3 80	5.00 (sw) 127	5.00 (sw) 127	11.6 5.3				
				5 125	x	5 125	x	1 25	5.50 (sw) 140	5.50 (sw) 140	14.0 6.4
				1 1/2 40				5.50 (sw) 140	5.50 (sw) 140	14.3 6.5	
				2 50				5.50 (sw) 140	5.50 (sw) 140	14.5 6.6	
2 1/2 65	5.50 (sw) 140	5.50 (sw) 140	15.2 6.9								
3 80	5.50 (sw) 140	5.50 (sw) 140	16.6 7.5								
4 100	5.50 (sw) 140	5.50 (sw) 140	16.7 7.6								
6 150	x	6 150	x	1 25				6.50 (sw) 165	6.50 (sw) 165	23.0 10.4	
1 1/2 40				6.50 (sw) 165				6.50 (sw) 165	24.0 10.9		
2 50				6.50 (sw) 165				6.50 (sw) 165	21.6 9.8		
2 1/2 65				6.50 (sw) 165				6.50 (sw) 165	21.4 11.7		
3 80				6.50 (sw) 165	6.50 (sw) 165	26.5 12.0					
4 100				6.50 (sw) 165	6.50 (sw) 165	25.0 11.3					
5 125				6.50 (sw) 165	6.50 (sw) 165	23.2 10.5					
6 1/2 165.1				x	6 1/2 165.1	x	3 80	6.50 (sw) 165	6.50 (sw) 165	24.0 10.9	
4 100							6.50 (sw) 165	6.50 (sw) 165	25.0 11.3		
5 125							6.50 (sw) 165	6.50 (sw) 165	23.2 10.5		

8 For 14/350 mm and larger roll grooved systems, Victaulic offers the Advanced Groove System (AGS). For pricing and availability of cut groove fittings in this size, contact your nearest Victaulic sales representative.

9 Cast fitting available. Contact Victaulic for details.

**Cap
No. 60**



No. 60



No. 60

Size		No. 60 Cap	
Nominal Size	Actual Outside Diameter	"T" Thickness	Approx. Weight Each
inches mm	inches mm	inches mm	lbs. kg
¾	1.050	0.88	0.2
20	26.9	22	0.1
1	1.315	0.88	0.3
25	33.7	22	0.1
1¼	1.660	0.88	0.3
32	42.4	22	0.1
1½	1.900	0.88	0.5
40	48.3	22	0.2
2	2.375	0.88	0.6
50	60.3	22	0.3
2½	2.875	0.88	1.0
65	73.0	22	0.5
76.1 mm	3.000	0.88	1.2
	76.1	22	0.5
3	3.500	0.88	1.2
80	88.9	22	0.5
3½	4.000	0.88	2.5
90	101.6	22	1.1
108.0 mm	4.250	1.00	2.3
	108.0	25	1.0
4	4.500	1.00	2.5
100	114.3	25	1.1
133.0 mm	5.250	1.00	4.5
	133.0	25	2.0
139.7 mm	5.500	1.00	4.5
	139.7	25	2.0
5	5.563	1.00	4.6
125	141.3	25	2.1

13 For 14/350 mm and larger roll grooved systems, Victaulic offers the Advanced Groove System (AGS). For pricing and availability of cut groove fittings in this size, contact your nearest Victaulic sales representative.

Size		No. 60 Cap	
Nominal Size	Actual Outside Diameter	"T" Thickness	Approx. Weight Each
inches mm	inches mm	inches mm	lbs. kg
159.0 mm	6.250 159.0	1.00 25	6.8 3.1
165.1 mm	6.500 165.1	1.00 25	7.3 3.3
6	6.625 168.3	1.00 25	6.1 2.8
8	8.625 219.1	1.19 30	13.1 5.9
10	10.750 273.0	1.25 32	21.0 9.5
12	12.750 323.9	1.25 32	35.6 16.2
14 ¹³	14.000 355.6	9.50 (s) 241	+
16 ¹³	16.000 406.4	10.00 (s) 254	+
18 ¹³	18.000 457.0	11.00 (s) 279	+
20 ¹³	20.000 508.0	12.00 (s) 305	+
24 ¹³	24.000 610.0	13.50 (s) 343	+
14 – 60 350 – 1500	For AGS fitting information, see publication 20.05 		

13 For 14/350 mm and larger roll grooved systems, Victaulic offers the Advanced Groove System (AGS). For pricing and availability of cut groove fittings in this size, contact your nearest Victaulic sales representative.

General Notes

No. 60 cap is not suitable for use in vacuum service with Style 72 or 750 couplings. No. 61 bull plugs should be used.

Note: All fittings are ductile iron unless otherwise noted with an (sw) or (s).

(s) = Carbon Steel Direct Roll Groove (DGR)

(sw) = Carbon Steel Segmentally Welded

+ Contact Victaulic for details.

Mechanical-T® Bolted Branch Outlets



STYLES 920 AND 920N

Victaulic Mechanical-T® Outlet provides a direct branch connection at any location a hole can be cut in pipe. The hole is cut oversize to receive a “holefinder” locating collar which secures the outlet in position permanently. A pressure responsive gasket seals on the pipe O.D.

Cross-type connections can be achieved by utilizing two upper housings of the same style and size, with the same or differing branch size connections. NOTE: Style 920 and Style 920N housings cannot be mated to each other to achieve a cross connection.

Style 920 and Style 920N Mechanical-T outlets are available with grooved or female threaded outlet. Specify choice on order. Units are supplied painted with plated bolts. Galvanized housings are available, supplied with plated bolts.

All sizes of Style 920 and 920N are rated at 500 psi/3450 kPa working pressure on Schedule 10 and 40 carbon steel pipe. They may also be used on high density polyethylene or polybutylene (HDPE) pipe. Pressure ratings on HDPE are dependent on the pipe rating. Contact Victaulic for ratings on other pipe. **Style 920 and 920N are not recommended for use on PVC plastic pipe.**

Standard piping practices dictate that the Mechanical-T Styles 920 and 920N must be installed so that the main and branch connections are a true 90° angle when permanently attached to the pipeline surface.

Additionally, the Vic-Tap II® hole cutting tool, which allows for hole cutting capabilities on pressurized systems, utilizes the Style 920 Mechanical-T in conjunction with the Series 726 Vic-Ball Valve to create the Style 931 Vic-Tap II Mechanical-T unit. See page 8 for further information.

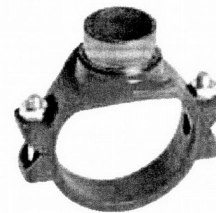

STYLES 920 AND 920N

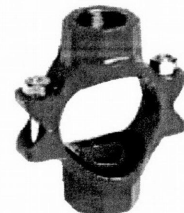

STYLE 920 CROSS

PATENTED

MATERIAL SPECIFICATIONS

Housing/Coating: Ductile iron conforming to ASTM A-536, grade 65-45-12, with orange enamel coating. Ductile iron conforming to ASTM A-395, grade 65-45-15, is available upon special request.

- **Optional:** Hot dipped galvanized

Gasket: (Specify choice*)

- **Grade “E” EPDM**
EPDM (Green color code). Temperature range -30°F to +230°F/-34°C to +110°C. Recommended for cold and hot water service within the specified temperature range plus a variety of dilute acids, oil-free air and many chemical services. UL Classified in accordance with ANSI/NSF 61 for cold +86°F/+30°C and hot +180°F/+82°C. NOT RECOMMENDED FOR PETROLEUM SERVICES.
- **Grade “T” nitrile**
Nitrile (Orange color code). Temperature range -20°F to +180°F/-29°C to +82°C. Recommended for petroleum products, air with oil vapors, vegetable and mineral oils within the specified temperature range. Not recommended for hot water services over +150°F/+66°C or for hot dry air over +140°F/+60°C.

*Services listed are General Service Recommendations only. It should be noted that there are services for which these gaskets are not recommended. Reference should always be made to the latest Victaulic Gasket Selection Guide for specific gasket service recommendations and for a listing of services which are not recommended.

Bolts/Nuts: Heat-treated plated carbon steel, trackhead meeting the physical and chemical requirements of ASTM A-449 and physical requirements of ASTM A-183.

JOB/OWNER

System No. _____
Location _____

CONTRACTOR

Submitted By _____
Date _____

ENGINEER

Spec Sect _____ Para _____
Approved _____
Date _____

Mechanical-T[®] Bolted Branch Outlets

STYLES 920 AND 920N

DIMENSIONS

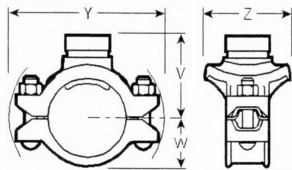

GROOVED OUTLET

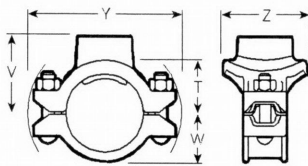

FEMALE THREADED OUTLET

- Provides a direct branch connection at any location where a hole can be cut in the pipe
- A pressure responsive gasket provides the seal
- Request Publication 11.03 for Mechanical-T cross assemblies
- Pressure rated up to 500 psi/3450 kPa on steel pipe; also available for use with HDPE pipe
- Sizes from 2 × ½/50 × 15 mm through 8 × 4/200 × 100 mm

Size Run × Branch Nominal Size Inches mm	Style No. 920 or 920N	Max. Work Pressure@ psi kPa	Dimensions							Approx. Weight Each			
			Hole Diameter +0.13 -0.00 Inches mm	T** Inches mm	V † # Thd. Inches mm	V ‡ Grv. Inches mm	W Inches mm	Y Inches mm	Z Inches mm	Female Thd. Lbs. kg	Grv. Lbs. kg		
2 50	× ½ (a) □ 15	920N	500 3450	1.50 38.1	2.00 51	2.53 64	—	1.61 41	5.35 136	2.75 70	3.1 1.5	—	
		920N	500 3450	1.50 38.1	1.97 50	2.53 64	—	1.61 41	5.35 136	2.75 70	3.1 1.5	—	
	1 (a) □ 25	920N	500 3450	1.50 38.1	1.85 47	2.53 64	—	1.61 41	5.35 136	2.75 70	3.0 1.4	—	
		920N	500 3450	1.75 44.5	2.05 52	2.75 70	3.00 76	1.61 41	5.35 136	3.00 76	3.5 1.7	3.2 1.5	
	1 ½ (a) † □ 40	920N	500 3450	1.75 44.5	2.03 52	2.75 70	3.12 79	1.61 41	5.35 136	3.25 83	3.6 1.7	3.2 1.5	
		920N	500 3450	1.50 38.1	2.21 56	2.74 70	—	1.82 46	5.64 143	2.75 70	3.0 1.4	—	
2 ½ 65	× ½ (a) § □ 15	920N	500 3450	1.50 38.1	2.18 55	2.74 70	—	1.82 46	5.64 143	2.75 70	3.0 1.4	—	
		920N	500 3450	1.50 38.1	2.06 52	2.74 70	—	1.82 46	5.64 143	2.75 70	2.9 1.4	—	
	1 (a) § □ 25	920N	500 3450	1.50 38.1	2.06 52	2.74 70	—	1.82 46	5.64 143	2.75 70	2.9 1.4	—	
		920N	500 3450	1.75 44.5	2.30 58	3.00 76	3.25 83	1.82 46	6.29 160	3.00 76	3.5 1.7	3.2 1.5	
	1 ¼ † (a) □ 32	920N	500 3450	2.00 50.8	2.28 58	3.00 76	3.25 83	1.82 46	6.26 159	3.25 83	3.6 1.7	3.3 1.6	
		920N	500 3450	1.50 38.1	2.22 56	2.75 70	—	2.25 57	6.46 164	3.18 81	3.9 1.8	—	
76.1	× ¾ (a) □ 20	920N	300 2065	1.50 38.1	2.19 56	2.75 70	—	2.25 57	6.46 164	3.18 81	3.9 1.8	—	
		920N	300 2065	1.50 38.1	2.07 53	2.75 70	—	2.25 57	6.46 164	3.18 81	3.8 1.7	—	
	1 (a) □ 25	920N	500 3450	1.75 44.5	2.30 58	3.00 76	3.31 84	1.92 49	6.29 160	3.00 76	3.5 1.6	3.2 1.5	
		920N	500 3450	2.00 50.8	2.28 58	3.00 76	3.31 84	1.92 49	6.29 160	3.25 83	3.5 1.6	3.3 1.5	
	1 ½ (a) □ 40	920N	500 3450	1.50 38.1	2.52 64	3.05 78	—	2.28 58	6.15 156	2.75 70	3.4 1.6	—	
		920N	500 3450	1.50 38.1	2.38 61	3.06 78	—	2.28 58	6.15 156	2.75 70	3.3 1.6	—	
3 80	× 1 (a) □ 25	920N	500 3450	1.75 44.5	2.55 65	3.25 83	3.56 90	2.28 58	6.15 156	3.00 76	3.8 1.8	3.7 1.8	
		920N	500 3450	2.00 50.8	2.78 71	3.50 89	3.56 90	2.28 58	6.15 156	3.25 83	4.1 1.9	3.8 1.8	
	1 ¼ (a) † □ 32 (b)	920N	500 3450	2.50 63.5	2.75 70	3.50 89	3.56 90	2.28 58	6.75 172	3.88 99	4.9 2.3	4.6 2.1	
		920N	500 3450	2.50 63.5	3.00 76	—	3.75 95	2.44 62	6.72 171	3.88 99	—	3.8 1.8	
	3 ½ 90	× 2 50	920N	500 3450	2.50 63.5	3.00 76	—	3.75 95	2.44 62	6.72 171	3.88 99	—	3.8 1.8

TABLE CONTINUED ON PG. 3

IMPORTANT NOTES:

Style 920 and Style 920N housings cannot be mated to one another to achieve cross connections.

** Center of run to engaged pipe end, female threaded outlet only (dimensions approximate).

† Available with grooved or female threaded outlet. Specify choice on order.

‡ Center of run to end of fitting.

Female threaded outlets are available to NPT and BSPT specifications.

@ See page 7 for Fire Protection approvals and pressure ratings.

(a) British Standard female pipe threaded outlet is available as listed. Specify "BSPT" clearly on order.

(b) For 76.1 mm threaded outlet, specify 2 ½" BSPT clearly on order.

§ Vds approved for fire protection services

□ LPCB approved for fire protection services

∅ Approved for use in China by Tianjin Approvals Company.

Mechanical-T® Bolted Branch Outlets

STYLES 920 AND 920N

DIMENSIONS

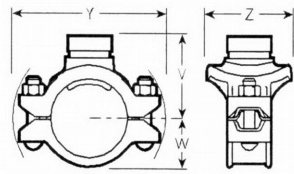

GROOVED OUTLET

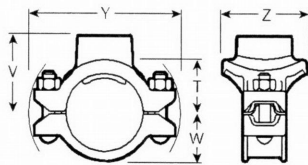

FEMALE THREADED OUTLET

- Provides a direct branch connection at any location where a hole can be cut in the pipe
- A pressure responsive gasket provides the seal
- Request Publication 11.03 for Mechanical-T cross assemblies
- Pressure rated up to 500 psi/3450 kPa on steel pipe; also available for use with HDPE pipe
- Sizes from 2 x 1/2"/50 x 15 mm through 8 x 4"/200 x 100 mm

Size Run x Branch Nominal Size Inches mm	Style No. 920 or 920N	Max. Work Pressure@ psi kPa	Dimensions							Approx. Weight Each		
			Hole Diameter +0.13 -0.00 Inches mm	T** Inches mm	V ‡ # Thd. Inches mm	V ‡ Grv. Inches mm	W Inches mm	Y Inches mm	Z Inches mm	Female Thd. Lbs. kg	Grv. Lbs. kg	
TABLE CONTINUED FROM PAGE 2												
4 100	1/2 (a) □	920N	500	1.50	3.03	3.56	—	2.69	7.01	2.75	3.7	—
			3450	38.1	77	90	—	68	178	70	1.8	—
	3/4 (a) □	920N	500	1.50	3.00	3.56	—	2.69	7.01	2.75	3.7	—
			3450	38.1	76	90	—	68	178	70	1.8	—
	1 (a) □	920N	500	1.50	2.88	3.56	—	2.69	7.01	2.75	3.6	—
			3450	38.1	73	90	—	68	178	70	1.8	—
	1 1/4 (a) †	920N	500	1.75	3.08	3.78	4.00	2.69	7.01	3.00	4.0	3.6
			3450	44.5	78	96	102	68	178	76	1.9	1.8
	1 1/2 (a) †	920N	500	2.00	3.28	4.00	4.00	2.69	7.01	3.25	4.2	3.9
			3450	50.8	83	102	102	68	178	83	2.0	1.9
2 (a) †	920N	500	2.50	3.25	4.00	4.00	2.69	7.01	3.88	5.0	4.6	
		3450	63.5	83	102	102	68	178	99	2.3	2.1	
2 1/2 (a) †	920	500	2.75	2.88	4.00	4.00	2.69	7.34	4.63	5.8	5.0	
		3450	69.9	73	102	102	68	186	118	2.6	2.3	
76.1 mm	920	500	2.75	2.88	4.00	4.00	2.69	7.34	4.63	—	6.4	
		3450	69.9	73	—	102	68	186	118	—	2.9	
3 (a) †	920	500	3.50	3.31	4.50	4.12	2.69	7.73	5.12	8.4	6.4	
		3450	88.9	84	114	105	68	196	130	3.8	2.9	
108.0	1 1/4 (a) □	920N	500	1.75	3.08	3.78	—	2.63	7.64	3.05	5.0	—
			3450	44.5	78	96	—	67	194	78	2.3	—
	1 1/2 (a) □	920N	500	2.00	3.28	4.00	—	2.63	7.64	3.25	5.0	—
			3450	50.8	83	102	—	67	194	83	2.3	—
	2 (a) †	920N	500	2.50	3.25	4.00	—	2.63	7.64	4.00	4.0	—
			3450	63.5	83	102	—	67	194	102	1.9	—
	76.1 mm	920	500	2.75	2.88	4.00	4.00	2.63	7.64	4.29	8.0	7.8
			3450	69.9	73	102	102	67	194	109	3.6	3.5
	3 (a) †	920	500	3.50	3.31	4.50	4.50	2.63	7.63	4.88	6.8	6.5
			3450	88.9	84	114	114	67	194	124	3.1	3.0
5 125	1 1/2 (a) †	920	500	2.00	4.03	4.75	4.75	3.16	9.70	3.69	7.4	7.6
			3450	50.8	102	121	121	80	246	94	3.4	3.4
	2 (a) †	920	500	2.50	4.00	4.75	4.75	3.16	9.70	4.38	8.2	8.0
			3450	63.5	102	121	121	80	246	111	3.7	3.6
	2 1/2 (a) †	920	500	2.75	3.63	4.75	4.75	3.16	9.70	4.63	8.3	7.9
			3450	69.9	92	121	121	80	246	118	3.8	3.6
76.1 mm □	920	500	2.75	3.75	—	4.75	3.16	9.70	4.63	—	8.0	
		3450	69.9	95	—	121	80	246	118	—	3.6	
3 (a) †	920	500	3.50	3.81	5.00	4.63	3.16	9.70	5.31	8.4	8.8	
		3450	88.9	97	127	118	80	246	135	3.8	4.0	
133.0	920N	500	2.50	3.75	4.50	—	3.17	8.00	3.88	8.0	—	
		3450	63.5	95	114	—	81	203	99	3.6	—	
3 80	920	500	3.50	3.81	5.00	—	3.00	9.46	5.31	8.0	—	
		3450	88.9	97	127	—	76	240	135	3.6	—	

TABLE CONTINUED ON PG. 4

IMPORTANT NOTES:

Style 920 and Style 920N housings cannot be mated to one another to achieve cross connections.

** Center of run to engaged pipe end, female threaded outlet only (dimensions approximate).

† Available with grooved or female threaded outlet. Specify choice on order.

‡ Center of run to end of fitting.

Female threaded outlets are available to NPT and BSPT specifications.

@ See page 7 for Fire Protection approvals and pressure ratings.

(a) British Standard female pipe threaded outlet is available as listed. Specify "BSPT" clearly on order.

(b) For 76.1 mm threaded outlet, specify 2 1/2" BSPT clearly on order.

§ Vds approved for fire protection services

□ LPCB approved for fire protection services

○ Approved for use in China by Tianjin Approvals Company.

Mechanical-T[®] Bolted Branch Outlets

STYLES 920 AND 920N

DIMENSIONS

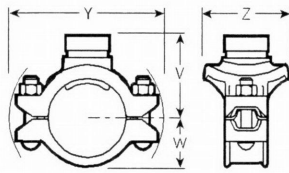

GROOVED OUTLET

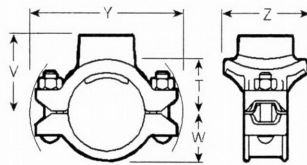

FEMALE THREADED OUTLET

- Provides a direct branch connection at any location where a hole can be cut in the pipe
- A pressure responsive gasket provides the seal
- Request Publication 11.03 for Mechanical-T cross assemblies
- Pressure rated up to 500 psi/3450 kPa on steel pipe; also available for use with HDPE pipe
- Sizes from 2 × ½"/50 × 15 mm through 8 × 4"/200 × 100 mm

IMPORTANT NOTES:

Style 920 and Style 920N housings cannot be mated to one another to achieve cross connections.

Size Run × Branch Nominal Size Inches mm	Style No. 920 or 920N	Max. Work Pressure@ psi kPa	Dimensions							Approx. Weight Each		
			Hole Diameter +0.13 -0.00 Inches mm	T** Inches mm	V ‡ # Thd. Inches mm	V ‡ Grv. Inches mm	W Inches mm	Y Inches mm	Z Inches mm	Female Thd. Lbs. kg	Grv. Lbs. kg	
TABLE CONTINUED FROM PAGE 3												
139.7 ×	1 ½ † 40	920N	500	2.00	3.78	4.50	—	3.30	8.23	3.25	7.0	—
		920	3450	50.8	96	114	—	84	209	83	3.2	—
6	2 † 50	920N	500	2.50	3.75	4.50	—	3.30	8.23	3.88	9.0	—
		920	3450	63.5	95	114	—	84	209	99	4.1	—
150 ×	1 ¼ (a) 32 (b)	920N	500	1.75	4.43	5.13	5.13	3.79	9.15	3.25	5.1	4.8
		920	3450	44.5	112	130	130	96	232	83	2.3	2.2
	1 ½ (a) † 40 (b)	920N	500	2.00	4.40	5.13	5.13	3.79	9.15	3.25	5.4	5.1
		920	3450	50.8	112	130	130	96	232	83	2.4	2.3
	2 (a) † 50	920N	500	2.50	4.38	5.13	5.13	3.79	9.15	3.88	6.0	5.6
		920	3450	63.5	111	130	130	96	232	99	2.7	2.5
	2 ½ 65	920	500	2.75	4.01	5.13	5.12	3.69	10.51	4.63	8.3	7.6
		920	3450	69.9	110	130	130	94	267	118	3.8	3.4
	76.1 mm ‡	920	500	2.75	4.15	—	5.21	3.69	10.51	4.63	—	8.4
		920	3450	69.9	105	—	132	94	267	118	—	3.8
	3 (a) † 80	920	500	3.50	4.31	5.50	5.13	3.69	10.51	5.31	9.9	8.4
		920	3450	88.9	110	140	130	94	267	135	4.5	3.8
	4 (a) † 100	920	500	4.50	3.81	5.75	5.38	3.69	10.51	6.25	10.1	10.1
		920	3450	114.3	97	146	137	94	267	159	4.6	4.6
TABLE CONTINUED ON PG. 5												
159.0 ×	1 ½ (a) 40	920N	500	2.00	4.41	5.13	—	3.63	9.40	3.25	7.8	—
		920	3450	50.8	112	130	—	92	239	83	3.5	—
	2 (a) 50	920N	500	2.50	4.38	5.13	—	3.63	9.40	3.88	8.0	—
		920	3450	63.5	111	130	—	92	239	99	3.6	—
	76.1 mm	920	500	2.75	4.38	5.50	5.13	3.63	9.40	4.63	9.5	9.5
		920	3450	69.9	111	140	130	92	239	118	4.3	4.3
	3 80	920	500	3.50	4.31	5.50	5.13	3.63	9.40	5.31	8.1	14.0
		920	3450	88.9	110	140	130	92	239	135	3.7	6.4
	108.0 mm	920	500	4.50	4.45	—	5.38	3.63	9.40	6.12	—	10.0
		920	3450	114.3	113	—	137	92	239	155	—	4.5
	4 100	920	500	4.50	3.81	5.75	—	3.63	9.40	6.25	18.0	—
		920	3450	114.3	96.80	146	—	92	239	159	8.2	—

** Center of run to engaged pipe end, female threaded outlet only (dimensions approximate).

† Available with grooved or female threaded outlet. Specify choice on order.

‡ Center of run to end of fitting.

Female threaded outlets are available to NPT and BSPT specifications.

@ See page 7 for Fire Protection approvals and pressure ratings.

(a) British Standard female pipe threaded outlet is available as listed. Specify "BSPT" clearly on order.

(b) For 76.1 mm threaded outlet, specify 2 ½" BSPT clearly on order.

§ Vds approved for fire protection services

⊞ LPCB approved for fire protection services

∅ Approved for use in China by Tianjin Approvals Company.

Mechanical-T[®] Bolted Branch Outlets

STYLES 920 AND 920N

DIMENSIONS

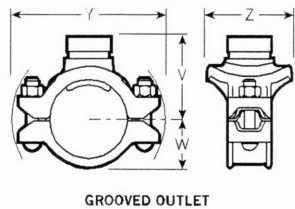

GROOVED OUTLET

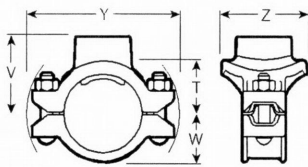

FEMALE THREADED OUTLET

- Provides a direct branch connection at any location where a hole can be cut in the pipe
- A pressure responsive gasket provides the seal
- Request Publication 11.03 for Mechanical-T cross assemblies
- Pressure rated up to 500 psi/3450 kPa on steel pipe; also available for use with HDPE pipe
- Sizes from 2 × 1/2"/50 × 15 mm through 8 × 4"/200 × 100 mm

Size Run × Branch Nominal Size Inches mm	Style No.	Max. Work Pressure@ psi kPa	Dimensions							Approx. Weight Each		
			Hole Diameter +0.13 -0.00 Inches mm	T** Inches mm	V ‡ # Thd. Inches mm	V ‡ Grv. Inches mm	W Inches mm	Y Inches mm	Z Inches mm	Female Thd. Lbs. kg	Grv. Lbs. kg	
TABLE CONTINUED FROM PAGE 4												
165.1 ×	1	920N	500	1.50	3.88	4.56	—	3.79	9.34	2.75	8.0	—
	25		3450	38.1	99	116	—	96	237	70	3.6	—
	1 1/4 □	920N	500	1.75	4.43	5.13	—	3.79	9.34	3.25	8.4	—
	32		3450	44.5	113	130	—	96	237	83	3.8	—
1 1/2 (a) † □	40	920N	500	2.00	4.41	5.13	5.13	3.79	9.34	3.25	8.4	5.4
			3450	50.8	112	130	130	96	237	83	3.8	2.4
2 (a) †	50	920N	500	2.50	4.38	5.13	5.13	3.79	9.34	3.88	8.5	6.0
			3450	63.5	111	130	130	96	237	99	3.9	2.7
76.1 mm		920	500	2.75	4.01	5.13	5.21	3.63	10.51	4.63	8.6	7.6
			3450	69.9	110	130	132	92	267	118	3.9	3.4
3 (a) † ∅	80	920	500	3.50	4.31	5.50	5.13	3.63	10.51	5.31	10.2	8.4
			3450	88.9	110	140	130	92	267	135	4.6	3.8
4 (a) † □	100	920	500	4.50	3.81	5.75	5.38	3.63	10.51	6.25	10.5	8.4
			3450	114.3	97	146	137	92	267	159	4.8	3.8
8 ×	2 (a) †	920	500	2.75	5.44	6.19	6.25	4.81	12.42	4.50	11.6	11.6
	50		3450	69.9	138	157	159	122	316	114	5.3	5.3
	2 1/2 (a) †	920	500	2.75	5.07	6.19	6.19	4.81	12.42	4.50	11.6	11.6
	65		3450	69.9	129	157	157	122	316	114	5.3	5.3
76.1 mm □		920	500	2.75	5.25	—	6.25	4.81	12.42	4.56	—	11.6
			3450	69.9	133	—	159	122	316	116	—	5.3
3 (a) † □	80	920	500	3.50	5.31	6.50	6.50	4.81	12.42	5.31	12.6	11.6
			3450	88.9	135	165	165	122	316	135	5.7	5.3
4 (a) † □	100	920	500	4.50	4.81	6.75	6.38	4.81	12.42	6.25	15.3	12.5
			3450	114.3	122	171	162	122	316	159	6.9	5.7

** Center of run to engaged pipe end, female threaded outlet only (dimensions approximate).

† Available with grooved or female threaded outlet. Specify choice on order.

‡ Center of run to end of fitting.

Female threaded outlets are available to NPT and BSPT specifications.

@ See page 7 for Fire Protection approvals and pressure ratings.

(a) British Standard female pipe threaded outlet is available as listed. Specify "BSPT" clearly on order.

(b) For 76.1 mm threaded outlet, specify 2 1/2" BSPT clearly on order.

§ Vds approved for fire protection services

□ LPCB approved for fire protection services

∅ Approved for use in China by Tianjin Approvals Company.

IMPORTANT NOTES:

Style 920 and Style 920N housings cannot be mated to each other to achieve cross connections.

Mechanical-T[®] Bolted Branch Outlets

STYLES 920 AND 920N

FLOW DATA

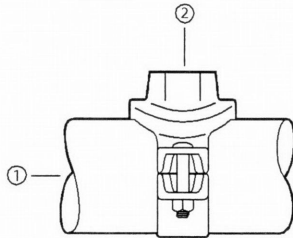

Exaggerated for clarity

Flow test data has shown that the total head loss between point (1) and (2) for the Style 920, 920N and 929 Mechanical-T[®] fittings can best be expressed in terms of the pressure difference across the inlet and branch. The pressure difference can be obtained from the relationship below.

C_v and K_v Values

Values for flow of water at +60°F/+16°C are shown in the table below.

Formulas for C_v, K_v Values:

$$\Delta P = \frac{Q^2}{C_v^2}$$

$$Q = C_v \times \sqrt{\Delta P}$$

Where:

Q = Flow (GPM)

ΔP = Pressure Drop (psi)

C_v = Flow Coefficient

$$\Delta P = \frac{Q^2}{K_v}$$

$$Q = K_v \times \sqrt{\Delta P}$$

Where:

Q = Flow (m³/h)

ΔP = Pressure Drop (bar)

K_v = Flow Coefficient

OUTLET SIZE		Equivalent Length of Outlet Size Schedule 40 Carbon Steel Pipe (per UL 213, Sec. 16) (C = 120)† FT		C _v /K _v Values	
NOMINAL DIAMETER In/mm	ACTUAL O.D. In/mm	GROOVED	THREADED	GROOVED	THREADED
½	0.840	-	2	-	11
15	21.3	-	-	-	9.4
¾	1.050	-	4	-	16
20	26.7	-	-	-	13.7
1	1.315	-	8	-	21
25	33.7	-	-	-	1.8
1 ¼	1.660	5 ½	6	50	48
32	42.7	-	-	42.9	41.1
1 ½	1.900	11	11	53	53
40	98.3	-	-	45.4	45.4
2	2.375	9	10 ½	112	104
50	60.3	-	-	96	89.1
2 ½	2.875	20	12 ½	119	150
65	73.0	-	-	102	128.5
76.1 mm	3.000	16*	-	161	-
	76.1	-	-	138.1	-
3	3.500	14	15 ½	249	237
80	88.9	-	-	213.4	203.1
4	4.500	20	22	421	401
100	114.3	-	-	360.8	343.6

† Hazen-Williams coefficient of friction is 120.

* Pipe with a wall thickness of 0.165in/4.2mm.

Mechanical-T® Bolted Branch Outlets

STYLES 920 AND 920N

FIRE PROTECTION APPROVALS AND PRESSURE RATINGS

The information provided below is based on the latest listing and approval data at the time of publication. Listings/Approvals are subject to change and/or additions by the approvals agencies. Contact Victaulic for performance on other pipe and the latest listings and approvals.

Run Size		Outlet Size	Pipe	Approval Agency Rated Working Pressures – psi/kPa					
Nominal Size Inches/mm	Actual Outside Diameter Inches/mm	Inches/mm	Schedule	UL	ULC	FM	LPCB	Vds	
								(Style 920)	(Style 920N)
2 1/2 - 6 65 - 150	2.875 - 6.625 73.0 - 168.3	All	10, 40	400	400	400	290	232	362
				2755	2755	2755	1999	1599	2496
2 1/2 - 4 65 - 100	2.875 - 4.500 73.0 - 114.3	All	DF	300	300	300	290	232	362
				2065	2065	2065	1999	1599	2496
2 1/2 - 4 65 - 100	2.875 - 4.500 73.0 - 114.3	All	SF	300	300	300	290	232	362
				2065	2065	2065	1999	1599	2496
6 150	6.625 168.3	3, 4	10	300	300	250	290	232	362
				2065	2065	1724	1999	1599	2496
6 150	6.625 168.3	3, 4	30, 40	300	300	300	290	232	362
				2065	2065	2065	1999	1599	2496
8 200	8.625 219.1	2 1/2	10, 40	400	—	—	—	145	—
				2755	—	—	—	1000	—
8 200	8.625 219.1	3, 4	10	300	—	250	—	145	—
				2065	—	1724	—	1000	—
8 200	8.625 219.1	3, 4	30, 40	300	—	300	—	145	—
				2065	—	2065	—	1000	—

NOTES:

- 10 refers to Listed/Approved Schedule 10 steel sprinkler pipe.
- 40 refers to Listed/Approved Schedule 40 steel sprinkler pipe.
- DF refers to Listed/Approved Dyna-Flow steel sprinkler pipe manufactured by American Tube Company.
- SF refers to Listed/Approved Super-Flo steel sprinkler pipe manufactured by Allied Tube and Conduit Corporation.

VIC-TAP II HOLE CUTTING TOOL FOR 4 - 8"/100 - 200 MM CARBON STEEL PIPE

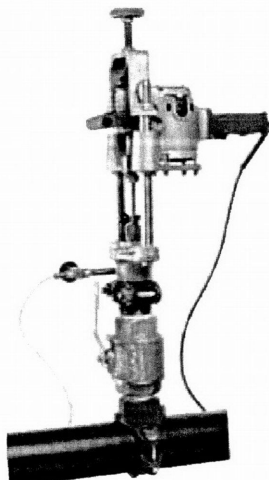

The Vic-Tap II hole cutting tool is designed for use with the Style 931 Vic-Tap II Mechanical-T unit, which is a combination of the Style 920 Mechanical-T and Series 726 Vic-Ball Valve. The Vic-Tap II is capable of tapping into carbon steel pipe systems under pressures up to 500 psi/3450 kPa.

The Style 931 Vic-Tap II Mechanical-T unit is a full port ball valve which can be mounted on 4"/100 mm, 5"/125 mm, 6"/150 mm and 8"/200 mm diameter pipe. The Style 931 comes with a 2 1/2"/65 mm grooved outlet.

The drill motor is an electric motor with ground fault circuit interrupter (GFCI) in accordance with safety codes.

For more information, refer to publication 24.01.

Mechanical-T[®] Bolted Branch Outlets

STYLES 920 AND 920N

INSTALLATION

Reference should always be made to the I-100 Victaulic Field Installation Handbook for the product you are installing. Handbooks are included with each shipment of Victaulic products for complete installation and assembly data, and are available in PDF format on our website at www.victaulic.com.

WARRANTY

Refer to the Warranty section of the current Price List or contact Victaulic for details.

NOTE

This product shall be manufactured by Victaulic or to Victaulic specifications. All products to be installed in accordance with current Victaulic installation/assembly Instructions. Victaulic reserves the right to change product specifications, designs and standard equipment without notice and without incurring obligations.

Dyna-Thread® – M-COAT®

Submittal Data Sheet

➤ Full Line Sch-40 Replacement

Dyna-Thread®–M-Coat® sprinkler pipe represents an engineering advancement for the sprinkler pipe industry. It combines the safety and longevity of traditional Sch-40 pipe with quality and superior hydraulic advantages.

➤ Comparison to Schedule 40

Dyna-Thread®–M-Coat® inside diameter is up to 3.6% larger than Sch-40 giving it superior hydraulics. Also, when used in combination with Dyna-Flow – M-Coat pipe, down sizing often occurs. Dyna-Thread is fully listed and approved UL, ULC, and FM for fire sprinkler applications. The life expectancy of Dyna-Thread – M-Coat and Sch-40 are equal based on the calculated wall thicknesses per UL. The consistent quality of steel used to make Dyna-Thread – M-Coat facilitates smooth threading and lower maintenance costs. The exterior of Dyna-Thread – M-Coat is protected by a clean, durable mill coating for extended shelf life and easy paint application. With its increased strength and lighter weight, Dyna-Thread – M-Coat reduces installation fatigue and is ideal for retro-fit applications. Corrosion Resistance Ratio (CRR) is a UL (Underwriters Laboratory) term for the estimated life expectancy of a pipe joint. This is based on the calculated wall thickness at the base of the first exposed thread, assumed to be the weakest point of the pipe length. Dyna-Thread – M-Coat and Sch-40 have the same calculated wall thicknesses at this point and are both assigned the same CRR of 1.00.

➤ Comparison to L.W.T. Pipe

More wall thickness at the thread (CRR=1.00) gives Dyna-Thread – M-Coat better life expectancy than lightwall threadable pipe joints. Dyna-Thread – M-Coat is approved for standard hanger spacing (15 ft. O.C.), can be used as earthquake sway bracing, and is safe to use as drops. Dyna-Thread – M-Coat is safer to weld on than many zinc coated lightwall threadable pipe products. Dyna-Thread – M-Coat is more widely accepted than lightwall threadable where Sch-40 is specified.

Dyna-Thread – M-COAT Specifications					
NPS In; mm	Nominal I.D. In; mm	Wt. Lbs/Ft; kg/m	Wt. (H2O Filled) Lbs/Ft; kg/m	CRR Unthreaded	CRR Threaded
1"	1.080	1.330	1.75	11.39	1.00
25	27.4	2.0	2.60	–	–
1¼"	1.408	1.870	2.54	9.50	1.00
32	35.8	2.8	3.78	–	–
1½"	1.639	2.290	3.22	9.14	1.00
40	41.6	3.4	4.79	–	–
2"	2.104	3.050	4.57	8.41	1.00
50	53.4	4.5	6.80	–	–



➤ American Made

Manufactured at one of 3 U.S. Facilities and is available through distributors in the USA, Canada, Mexico, and Latin America.

➤ Specifications & Approvals

Dyna-Thread – M-Coat pipe is manufactured to meet: ASTM A 135, Type E Grade A, and is in compliance with NFPA-13. All sizes of Dyna-Thread – M-Coat are rated at 300 psi working pressure. Dyna-Thread – M-Coat is UL and ULC Listed for wet, dry and pre-action sprinkler systems and FM Approved for use in wet systems. Dyna-Thread – M-Coat is approved for all threaded couplings and welded outlets and is suitable for all roll-grooved, and plain-end fittings. (See listing information).

Project: _____

Sprinkler Contractor: _____

Date: _____

Engineer: _____

Specification Reference: _____

System Type: _____

Locations: _____

Comments: _____



Customer Service: (800) 882-5543 Fax: (800) 659-7730

www.alliedtube-sprinkler.com

• 16100 S Lathrop Ave
Harvey, IL 60426

• 11350 Norcom Rd.
Philadelphia, PA 19154

• 2525 N 27th Ave.
Phoenix, AZ 85009

Ductile Iron Threaded Fittings



SMITH-COOPER[®]

INTERNATIONAL

Ductile Iron Threaded Fittings

Specifications

-  branded ductile iron threaded fittings are UL Listed and FM Approved at 500 psi
- Rated to 300 WSP
- Ductile iron castings conform to ASTM A536
- Fitting dimensions conform to ASME B16.3
- Bushings and plugs conform to ASME B16.14
- Fittings are 100% air tested
- NPT threads on all fittings conform to ASME B1.20.1
- Independent lab verification that fittings meet applicable chemical & physical properties
- Manufacturing facilities are ISO 9001:2008 and ISO 14001



Temperature Degrees F	Working Pressure, Nonshock psiG 300# Class Threaded Fittings
-20 to 100	500
150	500
200	480
250	460
300	440
350	420
400	400
450	380
500	360
550	340
600	320
650	300



Ductile Iron Fittings - Class 300 UL/FM

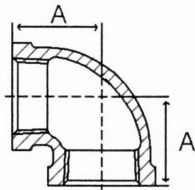

Fig. 35E 3 – 90° Elbow

Size in	Part Number	A in	Packing		Weight lb
			Inner	Master	
1/2	35E 3004	1.13	100	200	0.2
3/4	35E 3006	1.31	70	140	0.3
1	35E 3010	1.50	40	80	0.5
1-1/4	35E 3012	1.75	25	50	0.8
1-1/2	35E 3014	1.94	18	36	1.1
2	35E 3020	2.25	10	20	1.8
2-1/2	35E 3024	2.70	4	8	3.2

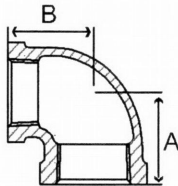

Fig. 35RE3 – 90° Reducing Elbow

Size in	Part Number	A in	B in	Packing		Weight lb
				Inner	Master	
3/4 x 1/2	35RE3006004	1.20	1.22	80	160	0.3
1 x 1/2	35RE3010004	1.26	1.36	70	140	0.4
1 x 3/4	35RE3010006	1.38	1.45	50	100	0.4
1-1/4 x 1/2	35RE3012004	1.34	1.53	35	70	0.5
1-1/4 x 3/4	35RE3012006	1.45	1.63	35	70	0.6
1-1/4 x 1	35RE3012010	1.58	1.67	30	60	0.7
1-1/2 x 1/2	35RE3014004	1.52	1.75	30	60	0.6
1-1/2 x 3/4	35RE3014006	1.52	1.75	25	50	0.7
1-1/2 x 1	35RE3014010	1.65	1.80	20	40	0.8
1-1/2 x 1-1/4	35RE3014012	1.82	1.88	18	36	1.0
2 x 1/2	35RE3020004	1.60	1.97	18	36	1.0
2 x 3/4	35RE3020006	1.60	1.97	18	36	1.0
2 x 1	35RE3020010	1.73	2.02	16	32	1.2
2 x 1-1/4	35RE3020012	1.90	2.10	12	24	1.3
2 x 1-1/2	35RE3020014	2.02	2.16	10	20	1.5
2-1/2 x 1-1/2	35RE3024014	2.16	2.51	6	12	2.2
2-1/2 x 2	35RE3024020	2.39	2.60	6	12	2.5

DUCTILE

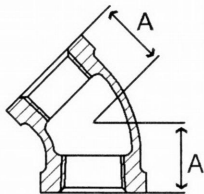

Fig. 35F 3 – 45° Elbow

Size in	Part Number	A in	Packing		Weight lb
			Inner	Master	
1/2	35F 3004	0.88	150	300	0.2
3/4	35F 3006	0.98	80	160	0.3
1	35F 3010	1.13	40	80	0.5
1-1/4	35F 3012	1.29	25	50	0.7
1-1/2	35F 3014	1.44	20	40	1.0
2	35F 3020	1.69	10	20	1.6
2-1/2	35F 3024	1.95	4	8	2.7

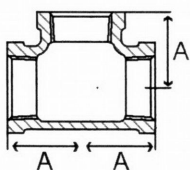

Fig. 35T 3 – Tee

Size in	Part Number	A in	Packing		Weight lb
			Inner	Master	
1/2	35T 3004	1.13	80	160	0.3
3/4	35T 3006	1.31	30	60	0.5
1	35T 3010	1.50	25	50	0.7
1-1/4	35T 3012	1.75	10	20	1.1
1-1/2	35T 3014	1.94	10	20	1.5
2	35T 3020	2.25	6	12	2.4
2-1/2	35T 3024	2.70	4	8	4.3



Ductile Iron Fittings - Class 300 UL/FM



Fig. 35RT3 – Reducing Tee

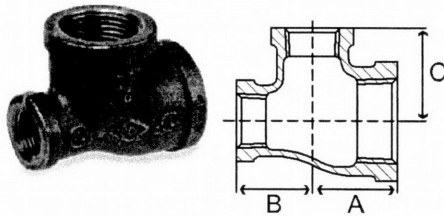

Size in	Part Number	A in	B in	C in	Packing		Weight lb
					Inner	Master	
3/4 x 1/2	35RT3006004	1.20	1.20	1.22	60	120	0.4
1 x 1/2	35RT3010004	1.26	1.26	1.36	30	60	0.6
1 x 1/2 x 1	35RT3010004010	1.50	1.36	1.50	30	60	0.6
1 x 3/4	35RT3010006	1.38	1.38	1.45	25	50	0.6
1 x 3/4 x 3/4	35RT3010006006	1.38	1.31	1.45	35	70	0.6
1 x 3/4 x 1	35RT3010006010	1.50	1.45	1.50	25	50	0.7
1-1/4 x 1/2	35RT3012004	1.34	1.34	1.53	20	40	0.8
1-1/4 x 1/2 x 1-1/4	35RT3012004012	1.75	1.53	1.75	25	50	0.9
1-1/4 x 3/4	35RT3012006	1.45	1.45	1.62	15	30	0.9
1-1/4 x 3/4 x 1-1/4	35RT3012006012	1.75	1.62	1.75	20	40	1.0
1-1/4 x 1	35RT3012010	1.58	1.58	1.67	15	30	1.0
1-1/4 x 1 x 1/2	35RT3012010004	1.34	1.26	1.53	25	50	0.7
1-1/4 x 1 x 3/4	35RT3012010006	1.45	1.38	1.63	20	40	0.8
1-1/4 x 1 x 1	35RT3012010010	1.58	1.50	1.69	20	40	0.9
1-1/4 x 1 x 1-1/4	35RT3012010012	1.75	1.69	1.75	15	30	1.0
1-1/2 x 1/2	35RT3014004	1.41	1.41	1.66	16	32	1.0
1-1/2 x 1/2 x 1-1/4	35RT3014004012	1.81	1.56	1.88	24	48	1.1
1-1/2 x 1/2 x 1-1/2	35RT3014004014	1.94	1.66	1.94	12	24	1.2
1-1/2 x 3/4	35RT3014006	1.52	1.52	1.75	16	32	1.1
1-1/2 x 3/4 x 1-1/4	35RT3014006012	1.94	1.66	1.88	20	40	1.1
1-1/2 x 3/4 x 1-1/2	35RT3014006014	1.94	1.75	1.94	18	36	1.2
1-1/2 x 1	35RT3014010	1.65	1.65	1.80	12	24	1.2
1-1/2 x 1 x 1/2	35RT3014010004	1.44	1.25	1.69	20	40	0.8
1-1/2 x 1 x 3/4	35RT3014010006	1.50	1.44	1.75	16	32	0.9
1-1/2 x 1 x 1	35RT3014010010	1.65	1.50	1.80	16	32	1.0
1-1/2 x 1 x 1-1/4	35RT3014010012	1.82	1.67	1.88	12	24	1.2
1-1/2 x 1 x 1-1/2	35RT3014010014	1.94	1.80	1.94	12	24	1.3
1-1/2 x 1-1/4	35RT3014012	1.82	1.82	1.88	12	24	1.4
1-1/2 x 1-1/4 x 1/2	35RT3014012004	1.41	1.34	1.66	16	32	0.9
1-1/2 x 1-1/4 x 3/4	35RT3014012006	1.52	1.45	1.75	16	32	1.0
1-1/2 x 1-1/4 x 1	35RT3014012010	1.65	1.58	1.80	16	32	1.1
1-1/2 x 1-1/4 x 1-1/4	35RT3014012012	1.82	1.75	1.88	14	28	1.3
1-1/2 x 1-1/4 x 1-1/2	35RT3014012014	1.94	1.88	1.94	14	28	1.4
2 x 1/2	35RT3020004	1.49	1.49	1.88	10	20	1.5
2 x 3/4	35RT3020006	1.60	1.60	1.97	10	20	1.6
2 x 1	35RT3020010	1.73	1.73	2.02	8	16	1.7
2 x 1 x 2	35RT3020010020	2.25	2.02	2.25	8	16	1.9
2 x 1-1/4	35RT3020012	1.90	1.90	2.10	8	16	1.9
2 x 1-1/4 x 2	35RT3020012020	2.25	2.10	2.25	8	16	2.0
2 x 1-1/2	35RT3020014	2.02	2.02	2.16	8	16	2.1
2 x 1-1/2 x 1/2	35RT3020014004	1.49	1.41	1.88	10	20	1.3
2 x 1-1/2 x 3/4	35RT3020014006	1.60	1.52	1.97	10	20	1.4
2 x 1-1/2 x 1	35RT3020014010	1.73	1.65	2.02	8	16	1.5
2 x 1-1/2 x 1-1/4	35RT3020014012	1.90	1.82	2.10	8	16	1.7
2 x 1-1/2 x 1-1/2	35RT3020014014	2.02	1.94	2.16	8	16	1.8

DUCTILE

Fig. 35BT3 – Bull Head Tee

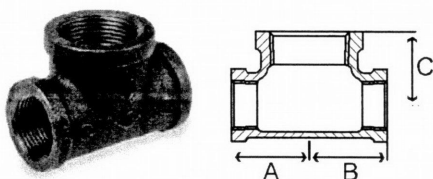

Size in	Part Number	A in	B in	C in	Packing		Weight lb
					Inner	Master	
3/4 x 1	35BT3006010	1.45	1.45	1.37	30	60	0.6
1 x 1-1/4	35BT3010012	1.67	1.67	1.58	20	40	0.9
1 x 1-1/2	35BT3010014	1.80	1.80	1.65	15	30	1.0
1-1/4 x 1 x 1-1/2	35BT3012010014	1.88	1.80	1.82	15	30	1.2
1-1/4 x 1-1/2	35BT3012014	1.88	1.88	1.82	15	30	1.3
1-1/4 x 2	35BT3012020	2.10	2.10	1.90	10	20	1.6
1-1/2 x 1-1/4 x 2	35BT3014012020	2.16	2.10	2.02	10	20	1.8
1-1/2 x 2	35BT3014020	2.16	2.16	2.02	8	16	1.8



Ductile Iron Fittings - Class 300 UL/FM

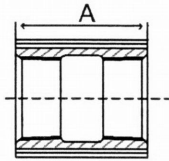
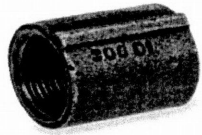

Fig. 35CP3 – Straight Coupling with Ribs

Size in	Part Number	A in	Packing		Weight lb
			Inner	Master	
1/2	35CP3004	1.38	200	400	0.1
3/4	35CP3006	1.63	100	200	0.2
1	35CP3010	1.75	60	120	0.4
1-1/4	35CP3012	2.00	35	70	0.5
1-1/2	35CP3014	2.19	25	50	0.7
2	35CP3020	2.62	15	30	1.2
2-1/2	35CP3024	3.00	9	18	2.2

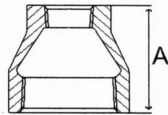

Fig. 35RC3 – Hex Reducing Coupling

Size in	Part Number	A in	Packing		Weight lb
			Inner	Master	
1 x 1/2	35RC3010004	1.69	80	160	0.3
1 x 3/4	35RC3010006	1.69	60	120	0.4
1-1/4 x 3/4	35RC3012006	2.06	40	80	0.6
2 x 1 (not hex)	35RC3020010	2.81	20	40	1.0

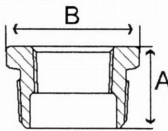

Fig. 35HB3 – Hex Bushing

Size in	Part Number	A in	Packing		Weight lb
			Inner	Master	
1 x 1/2	35HB3010004	1.06	180	360	0.2
1 x 3/4	35HB3010006	1.06	180	360	0.1
1-1/4 x 1	35HB3012010	1.19	90	180	0.2
1-1/2 x 1	35HB3014010	1.25	75	150	0.4
1-1/2 x 1-1/4	35HB3014012	1.25	75	150	0.3
2 x 1	35HB3020010	1.38	40	80	0.6
2 x 1-1/4	35HB3020012	1.38	40	80	0.6
2 x 1-1/2	35HB3020014	1.38	40	80	0.6

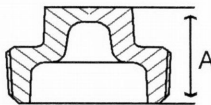

Fig. 35SP3 – Square Head Plug

Size in	Part Number	A in	Packing		Weight lb
			Inner	Master	
1/2	35SP3004	0.94	600	1200	0.07
3/4	35SP3006	1.12	350	700	0.1
1	35SP3010	1.25	200	400	0.1
1-1/4	35SP3012	1.37	100	200	0.3
1-1/2	35SP3014	1.44	80	160	0.4
2	35SP3020	1.50	45	90	0.6

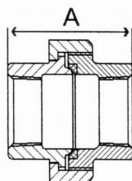
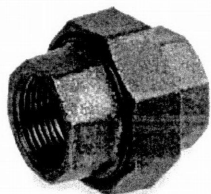

Fig. 35U3 – Union with Brass Seat

Size in	Part Number	A in	Packing		Weight lb
			Inner	Master	
1	35U 3010	2.19	20	40	1.0
1-1/4	35U 3012	2.50	15	30	1.2
1-1/2	35U 3014	2.62	10	20	1.7
2	35U 3020	3.12	6	12	2.4



Ductile Iron Fittings - Class 300 UL/FM

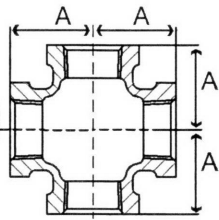

Fig. 35X 3 – Cross

Size in	Part Number	A in	Packing		Weight lb
			Inner	Master	
1	35X 3010	1.50	20	40	0.9
1-1/4	35X 3012	1.75	12	24	1.4
1-1/2	35X 3014	1.94	8	16	1.8
2	35X 3020	2.25	6	12	2.8

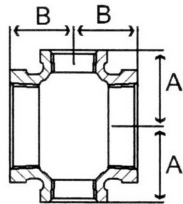

Fig. 35RX3 – Reducing Cross

Size in	Part Number	A in	B in	Packing		Weight lb
				Inner	Master	
1-1/4 x 1	35RX3012010	1.67	1.58	15	30	1.2
1-1/2 x 1	35RX3014010	1.80	1.65	12	24	1.4
2 x 1	35RX3020010	2.02	1.73	8	16	2.0

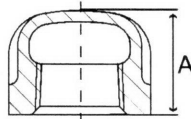

Fig. 35C 3 – Cap

Size in	Part Number	A in	Packing		Weight lb
			Inner	Master	
1/2	35C 3004	0.87	300	600	0.1
3/4	35C 3006	0.97	200	400	0.1
1	35C 3010	1.16	110	220	0.2
1-1/4	35C 3012	1.28	70	140	0.4
1-1/2	35C 3014	1.33	50	100	0.5
2	35C 3020	1.45	25	50	0.8
2-1/2	35C 3024	1.70	18	36	1.6

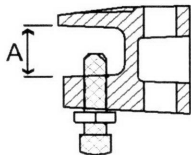

Fig. 35BC3 – Beam Clamp

Size in	Part Number	A in	Packing		Weight lb
			Inner	Master	
3/8	35BC3003	0.75	100	200	0.3
1/2	35BC3004	0.75	80	160	0.5

DUCTILE

Pipe Hangers

Fig. 200 - "Trimline" Adjustable Band Hanger (B-Line Fig. B3170NF)

Fig. 200F - "Trimline" Adjustable Band Hanger with Felt Lining (B-Line Fig. B3170NFF)

Fig. 200C - "Trimline" Adjustable Band Hanger with Plastic Coated (B-Line Fig. B3170NFC)

Fig. 200S - "Trimline" Adjustable Band Hanger with Non-Captured Nut



Size Range:

Fig. 200 - 1/2" (15mm) thru 8" (200mm) pipe

Material: Steel, Pre-Galvanized to G90 specifications

Function: For fire sprinkler and other general piping purposes. Knurled swivel nut design permits hanger adjustment after installation.

Features:

- (1/2" (15mm) thru 2" (50mm)) Flared edges ease installation for all pipe types and protect CPVC plastic pipe from abrasion. Captured design keeps adjusting nut from separating with hanger. Hanger is easily installed around pipe.
- For hanger with non-captured nut order Fig. 200S.
- (2 1/2" (65mm) thru 8" (200mm)) Spring tension on nut holds it securely in hanger before installation. Adjusting nut is easily removed.

Approvals: Underwriters Laboratories listed (1/2" (15mm) thru 8" (200mm)) in the USA (**UL**) and Canada (**cUL**) for steel and CPVC plastic pipe and Factory Mutual Engineering Approved (**FM**) (3/4" (20mm) thru 8" (200mm)). Conforms to Federal Specifications WW-H-171E & A-A-1192A, Type 10 and Manufacturers Standardization Society ANSI/MSS SP-69 & SP-58, Type 10.

Maximum Temperature: 650°F (343°C)

Finish: Pre-Galvanized. Stainless Steel materials will be supplied with (2) hex nuts in place of a knurl nut.

Order By: Figure number and pipe size

Designed to meet or exceed requirements of FM DS 2-0.

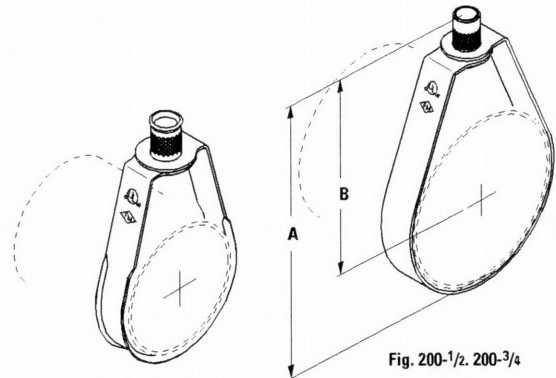

Fig. 200-1 to 200-2

Fig. 200-1/2, 200-3/4
Fig. 200-2 1/2 to 200-8



Fig. 200C

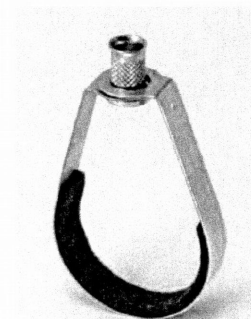

Fig. 200F

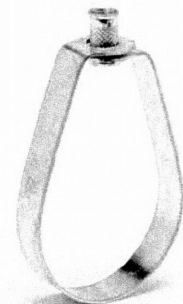

Fig. 200

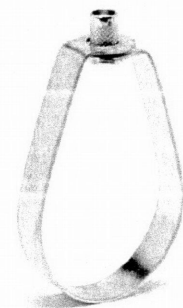

Fig. 200S

Part No.	Pipe Size		Rod Size	A		B		Approx. Wt./100	
	in.	(mm)		in.	(mm)	in.	(mm)	lbs.	(kg)
200-1/2	1/2"	(15)	3/8"-16	3 1/8"	(79.4)	2 5/8"	(66.7)	11	(5.0)
200-3/4	3/4"	(20)	3/8"-16	3 1/8"	(79.4)	2 1/2"	(63.5)	11	(5.0)
200-1	1"	(25)	3/8"-16	3 3/8"	(85.7)	2 5/8"	(66.7)	12	(5.5)
200-1 1/4	1 1/4"	(32)	3/8"-16	3 3/4"	(94.0)	2 7/8"	(73.0)	13	(5.9)
200-1 1/2	1 1/2"	(40)	3/8"-16	3 7/8"	(98.4)	2 7/8"	(73.0)	14	(6.4)
200-2	2"	(50)	3/8"-16	4 1/2"	(114.3)	3"	(76.3)	15	(6.9)
200-2 1/2	2 1/2"	(65)	3/8"-16	5 5/8"	(142.9)	4 1/8"	(104.7)	27	(12.3)
200-3	3"	(75)	3/8"-16	5 7/8"	(149.1)	4"	(101.6)	29	(13.3)
200-3 1/2	3 1/2"	(90)	3/8"-16	7 3/8"	(187.3)	5 1/4"	(133.3)	34	(15.6)
200-4	4"	(100)	3/8"-16	7 3/8"	(187.3)	5"	(127.0)	35	(16.0)
200-5	5"	(125)	1/2"-13	9 1/8"	(231.8)	6 1/4"	(158.7)	66	(30.2)
200-6	6"	(150)	1/2"-13	10 1/8"	(257.2)	6 3/4"	(171.4)	73	(33.4)
200-8	8"	(200)	1/2"-13	13 1/8"	(333.4)	8 3/4"	(222.2)	136	(62.3)

All dimensions in charts and on drawings are in inches. Dimensions shown in parentheses are in millimeters unless otherwise specified.

VERTICAL MOUNT

SAMMYS®

SAMMYS® for Wood *Installs VERTICALLY into the bottom of wood structures easily and quickly!*

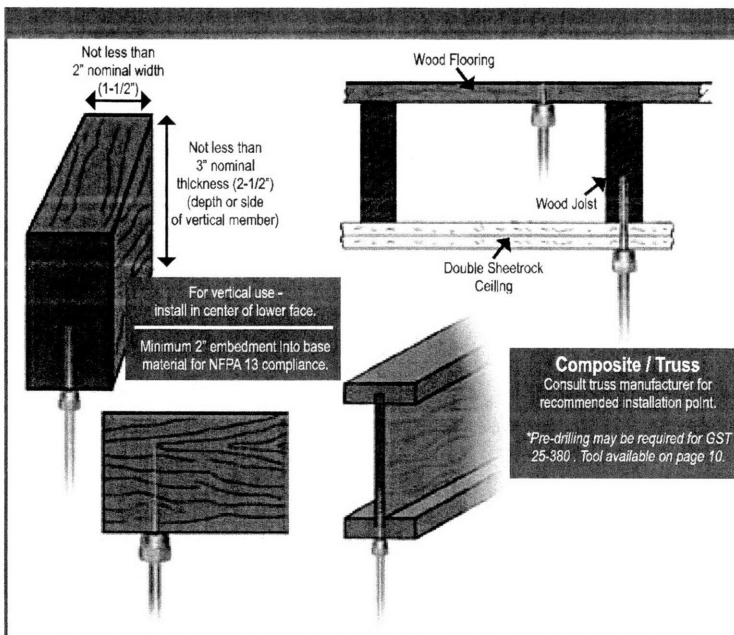

Product Features

- No pre-drilling required.
- Quick to install using the Sammy Nut Driver with an 18V cordless drill/driver.
- Saves time from traditional methods.
- Reduces installation cost.
- Made in the U.S.A.

Approvals	Rod Size	Part Number	Model	Screw Descriptions	Ultimate Pullout (lbs)	UL Test Load (lbs)	FM Test Load (lbs)	Box Qty	Case Qty
	1/4"	8002957	GST 100	1/4 x 1"	210 (7/16" OSB) 670 (3/4" Ply)			25	125
	1/4"	8003957	GST 200	1/4 x 2"	1760 (Fir)			25	125
	1/4"	8004957	GST 300	1/4 x 3"	2060 (Fir)			25	125
	3/8"	8006957	GST .75	1/4 x 3/4"	564 (3/4" Ply)			25	125
	3/8"	8007957	GST 10	1/4 x 1"	210 (7/16" OSB) 670 (3/4" Ply)	300		25	125
	3/8"	8008957	GST 20	1/4 x 2"	1760 (Fir)	850	1475	25	125
	3/8"	8068925	GST 20-SS	1/4 x 2"	1760 (Fir)	850		25	125
	3/8"	8009925	GST 25-380	3/8 x 2-1/2"	2113 (Fir)	1500		25	125
	3/8"	8010957	GST 30	1/4 x 3"	2060 (Fir)	1500	1475	25	125
	3/8"	8069925	GST 30-SS	1/4 x 3"	2060 (Fir)			25	125
	3/8"	8011925	GST 40	1/4 x 4"	2180 (Fir)			25	125
	3/8"	8012925	GST 60	1/4 x 6"	2230 (Fir)			25	125
	1/2"	8013925	GST 2	1/4 x 2"	1760 (Fir)			25	125
	1/2"	8014925	GST 2.5-380	3/8 x 2-1/2"	2113 (Fir)			25	125
	1/2"	8015925	GST 3	1/4 x 3"	2275 (Fir)			25	125
	1/2"	8016925	GST 4	1/4 x 4"	2180 (Fir)			25	125
	1/2"	8017925	GST 6	1/4 x 6"	2230 (Fir)			25	125



#14 Black Nut Driver Part # 8113910



#14 SW Red Nut Driver Part # 8114910

SAMMY Swivel Head® for Wood *Installs VERTICALLY and swivels up to 17° in wood structure*

Product Features

- Eliminates distortion of threaded rod.
- Accommodates up to 3 1/2" x 12 pitch roof.
- Allows 17° deflection from vertical.
- Saves time from traditional methods.
- Reduces installation cost.
- Made in the U.S.A.

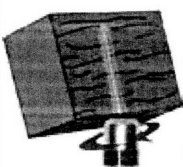

Approvals	Rod Size	Part Number	Model	Screw Descriptions	Ultimate Pullout (lbs)	UL Test Load (lbs)	FM Test Load (lbs)	Min Thickness	Box Qty	Case Qty
	3/8"	8139957	SH-GST 20	1/4 x 2"	1257 (Fir)	1050	1475	25	125	125
	3/8"	8141957	SH-GST 30	1/4 x 3"	1720 (Fir)	1500	1475	25	125	125



#14 Black Nut Driver Part # 8113910

SPECIAL NUT DRIVER SYSTEM: The nut drivers were designed with a unique spin-off feature which provides a fast and safe installation each time. When the face of the driver comes into contact with the material you are installing into, continue drilling until nut driver spins free. Installation is then complete. Warranty requires the use of the appropriate nut driver for installations.



Threaded Accessories

B3205 - Threaded Rod (right-hand threads - both ends) (TOLCO Fig. 103) B3205L - Threaded Rod (right & left hand threads)

Size Range: 3/8"-16 thru 3"-4 rod

Material: Steel

Function: Recommended for use as a hanger support in hanger assemblies. Rod is threaded on both ends with right hand threads of the length shown. Also available with left and right hand threads - specify Fig. B3205L when ordering.

Maximum Temperature: 750°F (399°C)

Finish: Plain. Contact B-Line for alternative finishes and materials.

Order By: Part number, rod size, length and finish

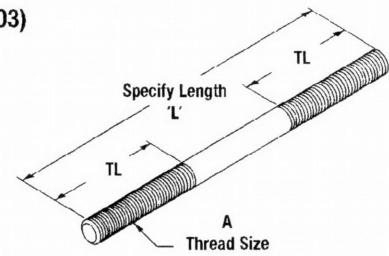

Part No.	Thread Size A	Standard Thread Length TL		Design Load			
		in.	(mm)	650°F (343°C)		750°F (399°C)	
				Lbs.	(kN)	Lbs.	(kN)
B3205-3/8 x 'L'	3/8"-16	2 1/2"	(63.5)	730	(3.25)	572	(2.54)
B3205-1/2 x 'L'	1/2"-13	2 1/2"	(63.5)	1350	(6.00)	1057	(4.70)
B3205-5/8 x 'L'	5/8"-11	2 1/2"	(63.5)	2160	(9.61)	1692	(7.52)
B3205-3/4 x 'L'	3/4"-10	3"	(76.2)	3230	(14.37)	2530	(11.25)
B3205-7/8 x 'L'	7/8"-9	3 1/2"	(88.9)	4480	(19.93)	3508	(15.60)
B3205-1 x 'L'	1"-8	4"	(101.6)	5900	(26.24)	4620	(20.55)
B3205-1 1/8 x 'L'	1 1/8"-7	4 1/2"	(114.3)	7450	(33.14)	5830	(25.93)
B3205-1 1/4 x 'L'	1 1/4"-7	5"	(127.0)	9500	(42.25)	7440	(33.09)
B3205-1 1/2 x 'L'	1 1/2"-6	6"	(152.4)	13800	(61.38)	10807	(48.07)
B3205-1 3/4 x 'L'	1 3/4"-5	7"	(177.8)	18600	(82.73)	14566	(64.79)
B3205-2 x 'L'	2"-4 1/2	8"	(203.2)	24600	(109.42)	19625	(87.29)
B3205-2 1/4 x 'L'	2 1/4"-4 1/2	9"	(228.6)	32300	(143.67)	25295	(112.51)
B3205-2 1/2 x 'L'	2 1/2"-4	10"	(254.0)	39800	(177.03)	31169	(138.64)
B3205-2 3/4 x 'L'	2 3/4"-4	11"	(279.4)	49400	(219.73)	38687	(172.08)
B3205-3 x 'L'	3"-4	12"	(304.8)	60100	(267.32)	47066	(209.35)

ATR - All Threaded Rod 120" (3.05m) Lengths (TOLCO Fig. 100) Fig. 99 - All Threaded Rod Cut To Length

Size Range: 3/8"-16 thru 1 1/2"-6 rod in 120" (3.05m) lengths or cut to length

Material: Steel

Maximum Temperature: 750°F (399°C)

Finish: Plain. Contact B-Line for alternative finishes and materials.

Order By: Part number, rod diameter and finish

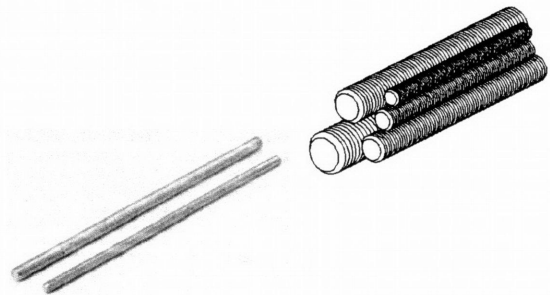

Part No. - Size x Length ATR	Fig.99	Threads Per Inch	Recommended Load		Approx. Wt./100 Ft.	
			Lbs.	(kN)	Lbs.	(kg)
ATR 1/4" x 120	99-1/4" x length	20	240	(1.07)	12	(5.44)
ATR 3/8" x 120	99-3/8" x length	16	730	(3.24)	29	(13.15)
ATR 1/2" x 120	99-1/2" x length	13	1350	(6.00)	53	(24.04)
ATR 5/8" x 120	99-5/8" x length	11	2160	(9.60)	89	(40.37)
ATR 3/4" x 120	99-3/4" x length	10	3230	(14.37)	123	(55.79)
ATR 7/8" x 120	99-7/8" x length	9	4480	(19.93)	170	(77.11)
ATR 1" x 120	99-1" x length	8	5900	(26.24)	225	(102.06)

All dimensions in charts and on drawings are in inches. Dimensions shown in parentheses are in millimeters unless otherwise specified.

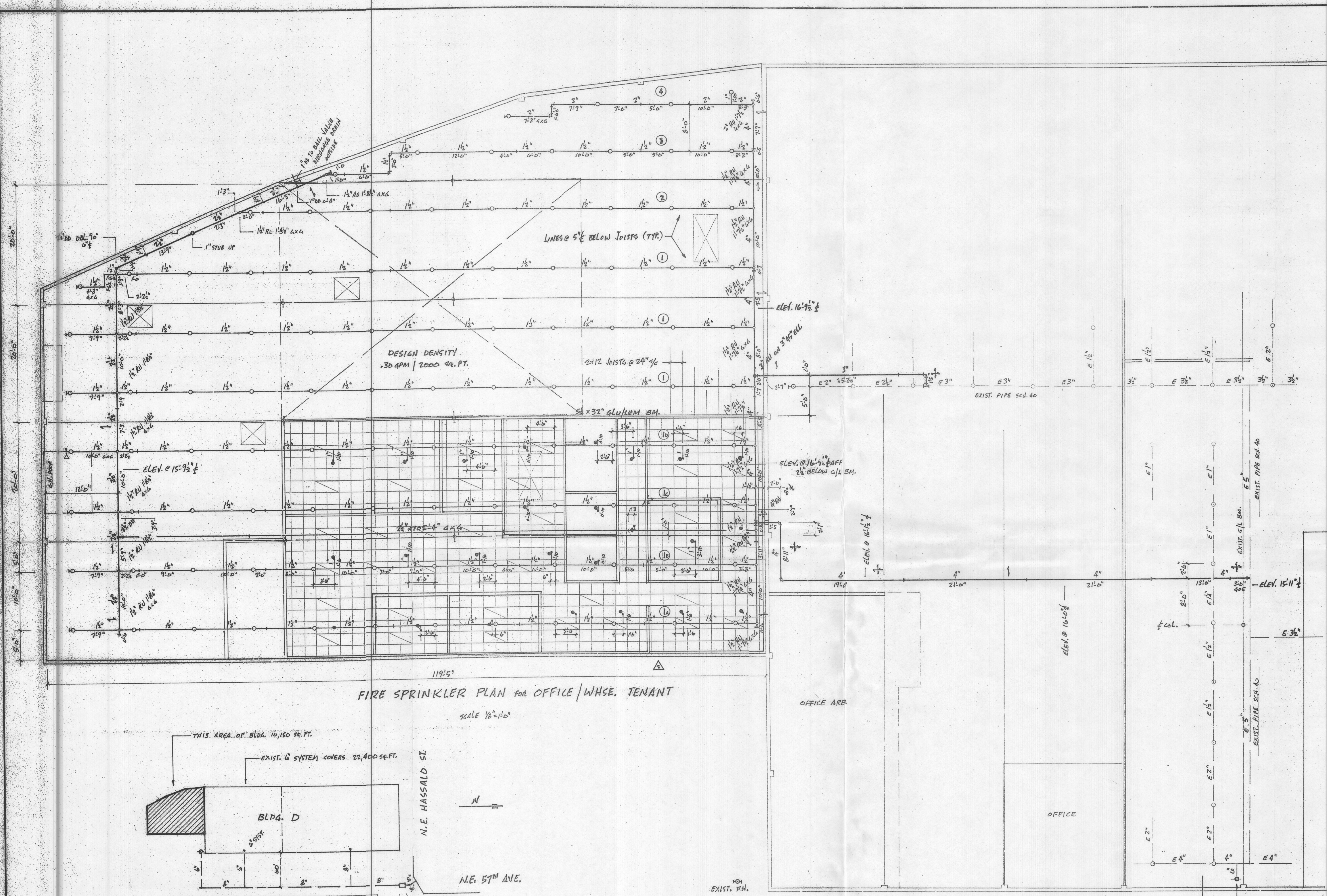

FIRE SPRINKLER PLAN FOR OFFICE/WHSE. TENANT

SCALE 1/8"=1'-0"

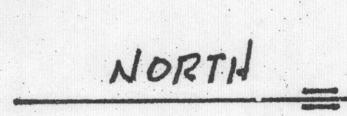

GENERAL NOTES

GENERAL OCCUPANCY IS DRD. HAZ. GR. 2 WITH STORAGE CAPABILITIES ABOVE 12' HIGH. FUTURE OFFICE AREAS WILL COMPLY WITH LIGHT HAZ. STANDARDS. DESIGN DENSITY ALLOWING FOR RACK STORAGE OF CLASS 4 NONENCAPSULATED PRODUCT ON 5'x8' PALLETS UP TO 15' HIGH 1/2' WIDE AISLES, OR CLASS 3 PRODUCT UP TO 18' HIGH.

ALL NEW PIPING IS SCH. 40 STEEL OR UL APPROVED LIGHTWALL FOR FIRE SPRINKLER USE. ALL MATERIAL TO BE NEW & UL APPROVED AND INSTALLED TO COMPLY WITH LATEST ISSUE OF NFPA #13.

APPROVED FOR CONDITIONS SHOWN AND SUBJECT TO FINAL INSPECTION BY FIRE MARSHAL PORTLAND, OREGON

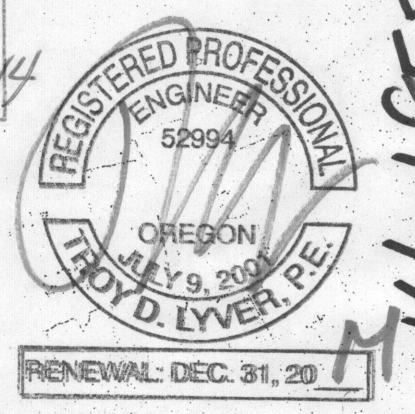

BY: JHP DATE 7-17-14

6" A.L. ALARM CK. VA. 6" D.S. 4" GATE VA.

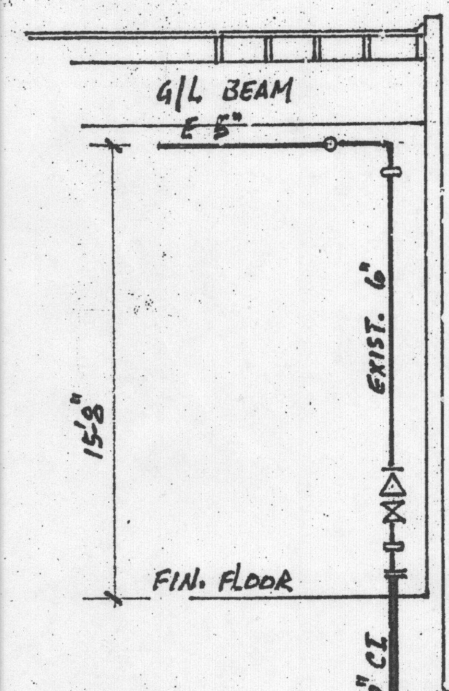

EXIST. VA. RISER DETAIL A

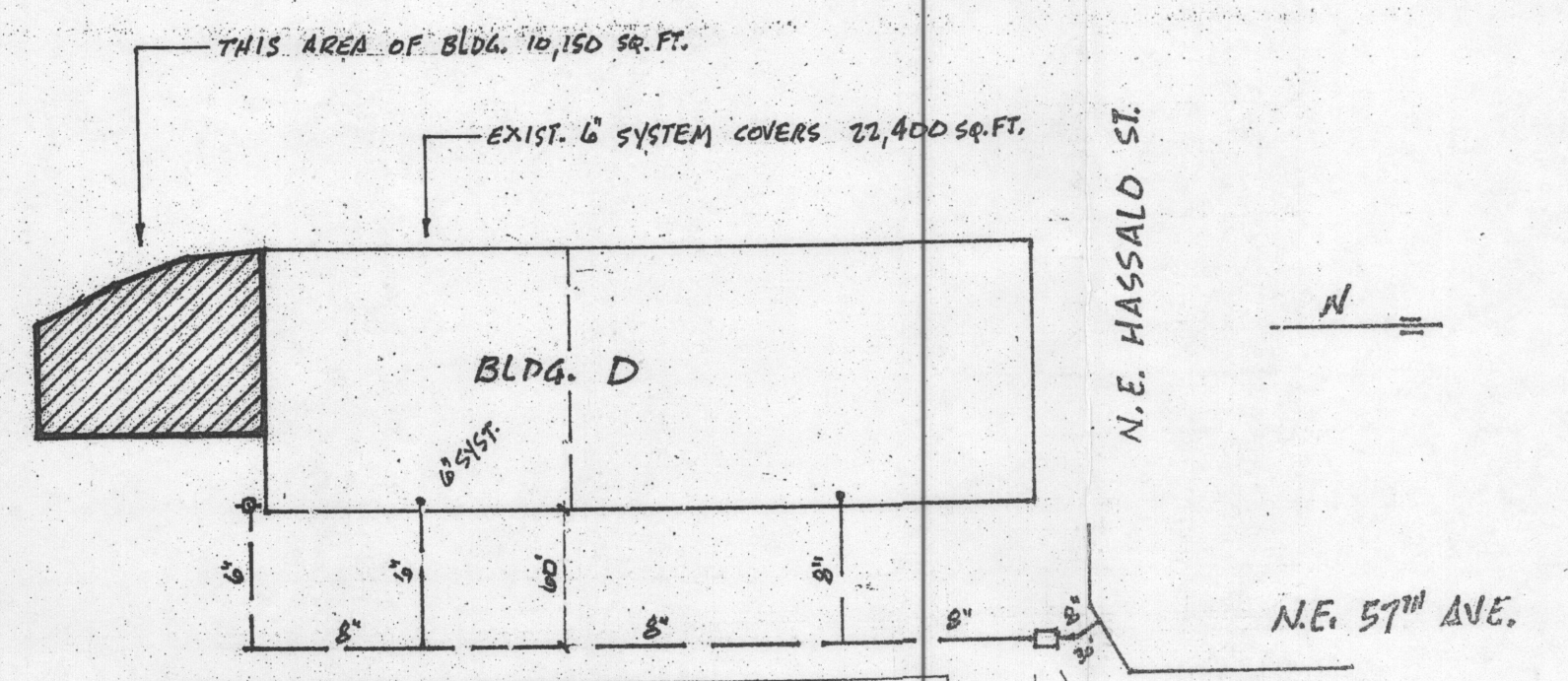

SITE PLAN 1"=100'

WATER FLOW TEST DATA 71 PSI STATIC 49 PSI RESIDUAL @ 2500 GPM FLOWING

DEVICES-					SPRINKLER HEAD SYMBOLS	
SYM.	SPRINKLERS	TYPE	FAC	DEGREE	QTY.	
○	TYCO (TY413) 3/4" K 8.0	UPR.	S.D	25.0	104	○ UPRIGHT ON OUTLET
○	TYCO (TY413) 3/4" K 8.0	UPR.	S.D	25.0	104	○ PENDENT ON 1/2" OUTLET
○	TY4131 3/4" HEAD ON 1 1/2" 2" ED	JPR.	S.D	25.0	1	○ UPRIGHT ON 1" STUBB-UP
○	TYCO 1/2" HORIZONTAL SW. H.	PEND.	S.L	155	2	○ FLUSH SPR. ON 1" DROP
○	TYCO (TY323) 1/2" CWR. RELEASED	PEND.	S.L	155	25	○ DRY PENDENT ON 1" DROP
						○ SIDEWALL ON 1/2" OUTLET
						○ UP & DN AT SAME LOCATION

REVISIONS - LOCATE BY GRD COORDINATES	
1	ADD 2 1/2" MAIN & 3" SECONDARY FEED / GENERAL NOTES 9/B
2	OFFICE AREA T.I.

APPROVALS & INSPECTION	
1	DATE 5/16
2	
3	
4	
5	
6	
7	
8	
9	
10	

CONTRACT WITH		CONTRACT		DATE	
-G.C./OWNER-		ENGINEER	A	5/15/14	SHEET
ADDRESS		B. PEARSON		FP-1	
CITY		FIRE SPRINKLER PLAN BANFIED IND. PARK PTR #61 5600 NE-HASSALD PORTLAND OR			
PHONE					
ARCHITECT					
ADDRESS					
CITY					
PHONE					

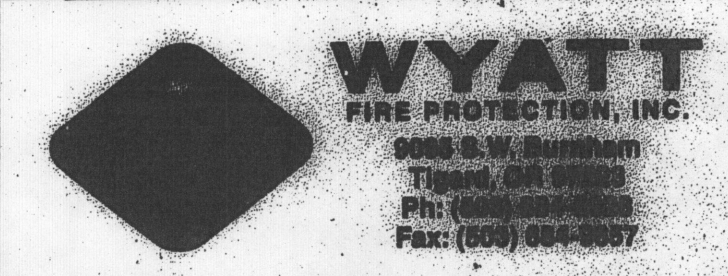

14-185397FA