



MIRACLES CENTRAL DESIGN REVIEW

The Miracles Club



CARLETON HART
ARCHITECTURE



PROJECT GOALS & PROGRAM

PROJECT DEVELOPER:

- MULTI-CULTURAL DEVELOPMENT GROUP, LLC

CO-DEVELOPER & PROPERTY MANAGER:

- GUARDIAN REAL ESTATE SERVICES, LLC

CO-SPONSORS:

- MIRACLES CLUB
- CENTRAL CITY CONCERN
- WORKING TOGETHER TO PROVIDE SUPPORTIVE RECOVERY BASED HOUSING
- 47 UNITS OF AFFORDABLE HOUSING
- COMMUNITY SUPPORT SERVICES
- SIX STORIES - WOOD FRAMING OVER A CONCRETE PODIUM APPROXIMATELY 47,500 SF

DESIGN REVIEW SUMMARY

1. PROJECT REVIEW

2. DESIGN ADVICE SUMMARY & SOLUTIONS

3. MODIFICATION REQUESTS



- VICINITY MAP KEYNOTES**
- ① LEGACY HEALTH CENTER
 - ② OREGON CONVENTION CENTER
 - ③ MODA CENTER
 - ④ MEMORIAL COLISEUM
 - ⑤ CROWN PLAZA PORTLAND - DOWNTOWN CONVENTION CENTER
 - ⑥ HOLY ROSARY CHURCH



VICINITY MAP

MIRACLES CENTRAL



SITE MAP

MIRACLES CENTRAL



SITE FROM NORTH



SITE FROM WEST



SITE FROM SOUTHEAST



SITE FROM SOUTHWEST

SITE PHOTOS

MIRACLES CENTRAL



LOOKING WEST AT 3RD, BETWEEN WASCO & CLACKAMAS



LOOKING NORTHEAST AT 3RD & CLACKAMAS



LOOKING EAST AT 3RD & WASCO



LOOKING NORTHWEST AT 3RD, BETWEEN WASCO & CLACKAMAS

SITE CONTEXT PHOTOS

MIRACLES CENTRAL



LOOKING SOUTHEAST AT 3RD & WASCO



LOOKING NORTHEAST AT 2ND & CLACKAMAS

NEIGHBORHOOD CONTEXT PHOTOS

MIRACLES CENTRAL



LOOKING SOUTHWEST AT 2ND & WASCO



LOOKING WEST AT 2ND, BETWEEN WASCO & CLACKAMAS



LOOKING SOUTH FROM SITE



LOOKING NORTHWEST ACROSS SITE

NEIGHBORHOOD CONTEXT PHOTOS



SITE PLAN

MIRACLES CENTRAL

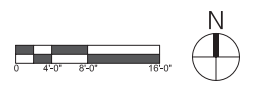



SECOND & FOURTH FLOOR PLAN

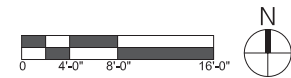

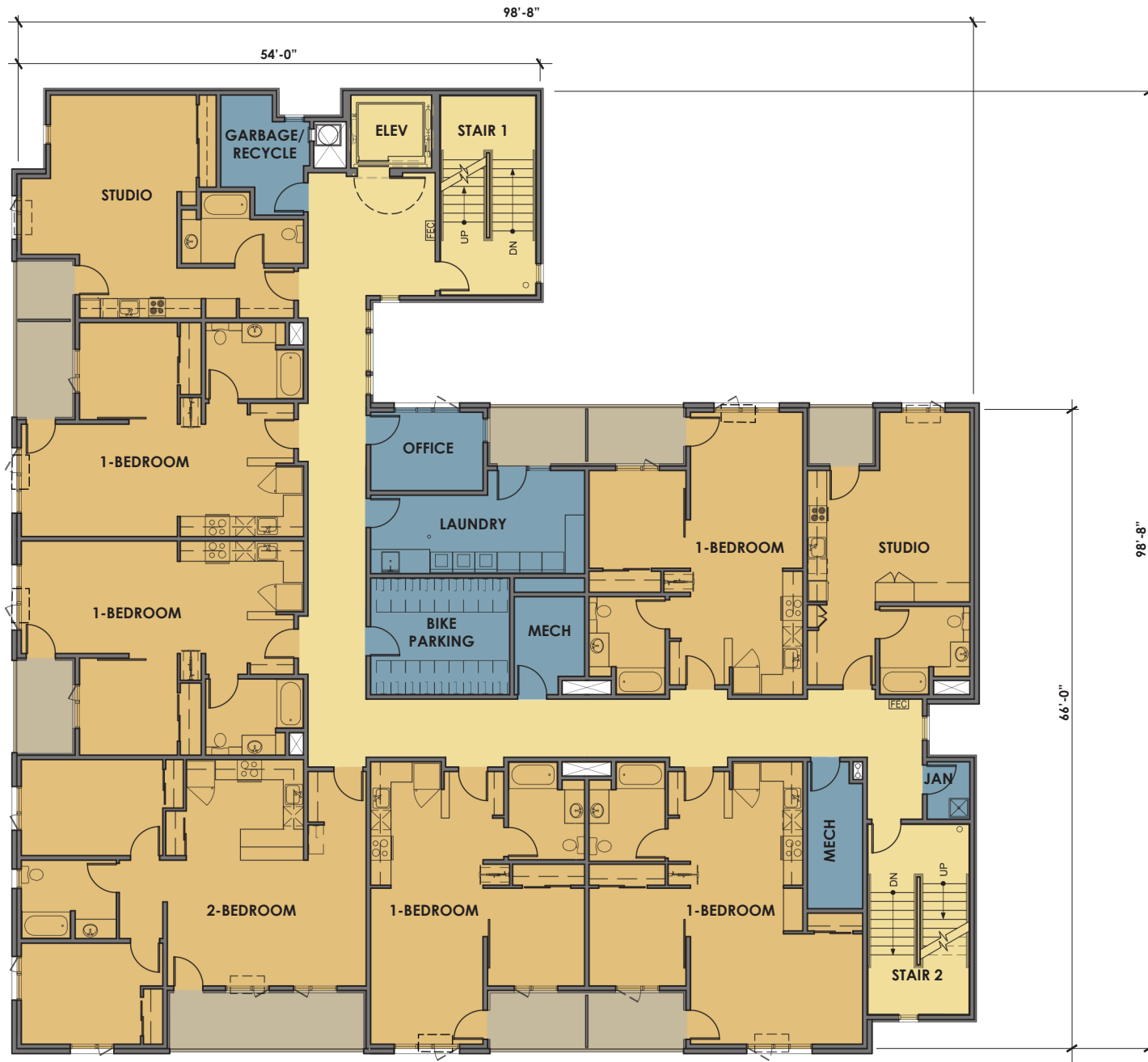

THIRD & FIFTH FLOOR PLAN

MIRACLES CENTRAL

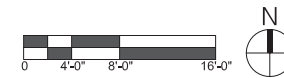



SIXTH FLOOR PLAN

MIRACLES CENTRAL

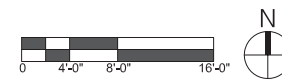

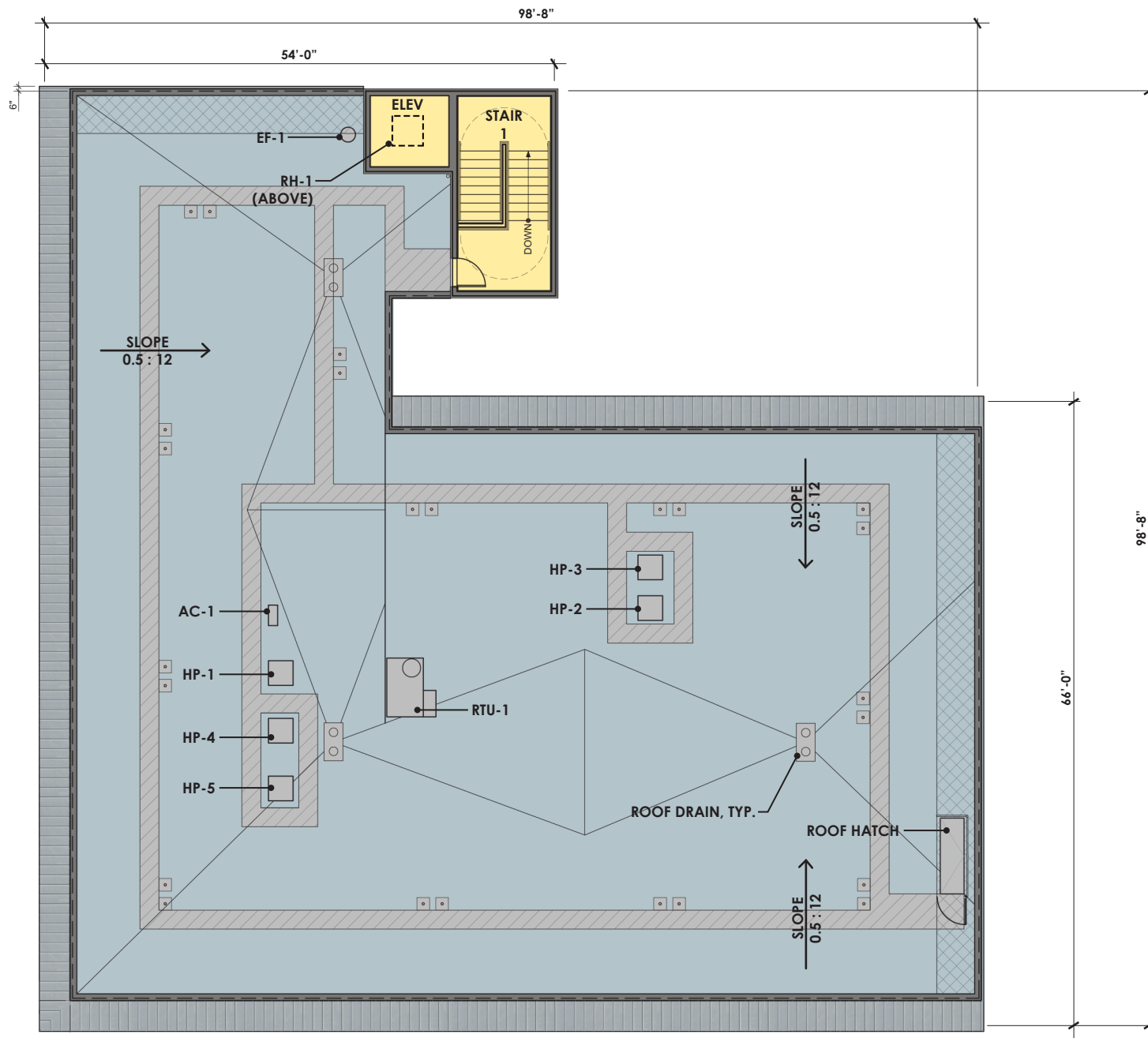

ROOF PLAN

MIRACLES CENTRAL

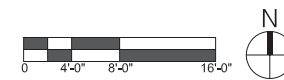

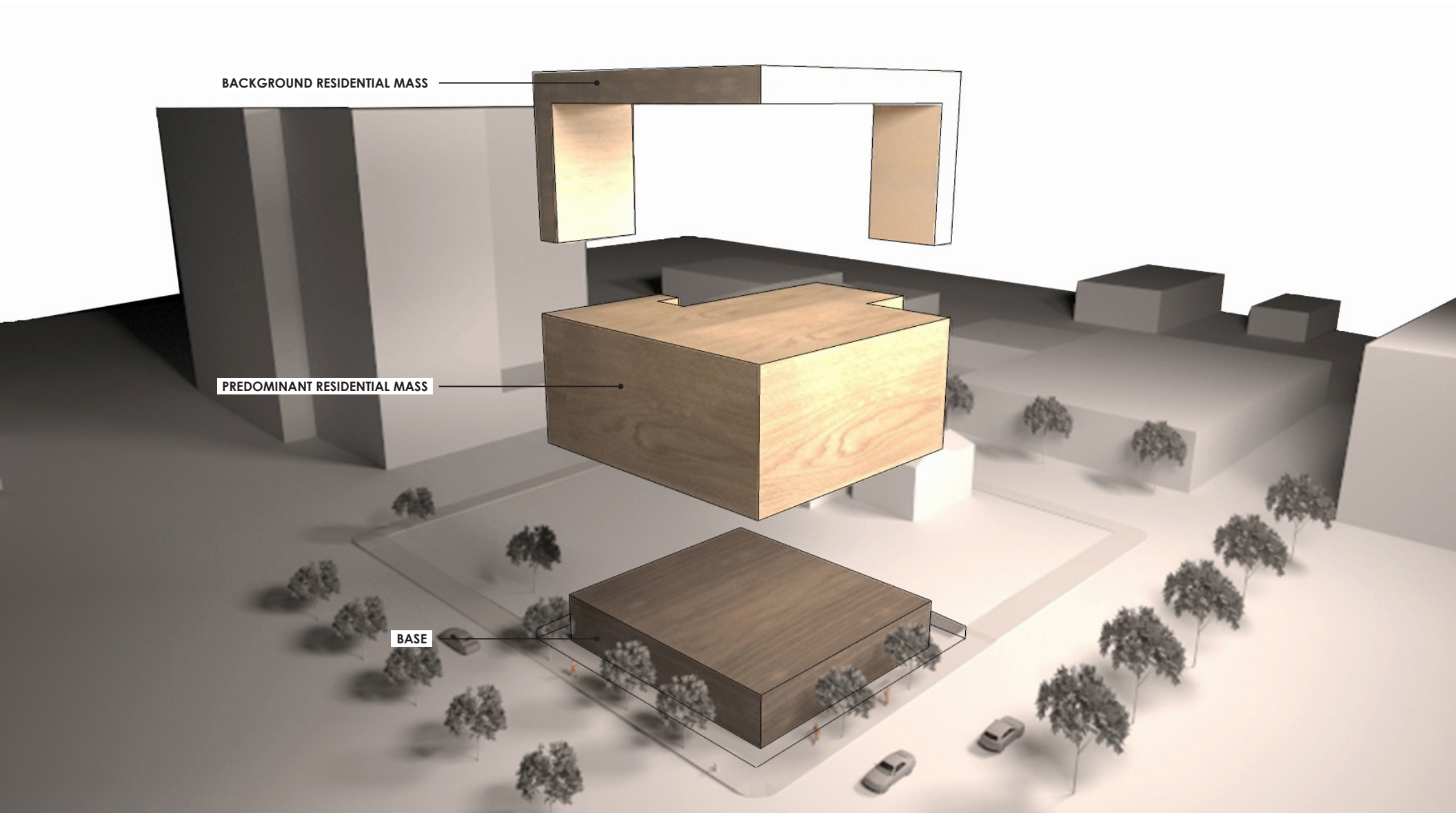

MASSING DIAGRAM

MIRACLES CENTRAL

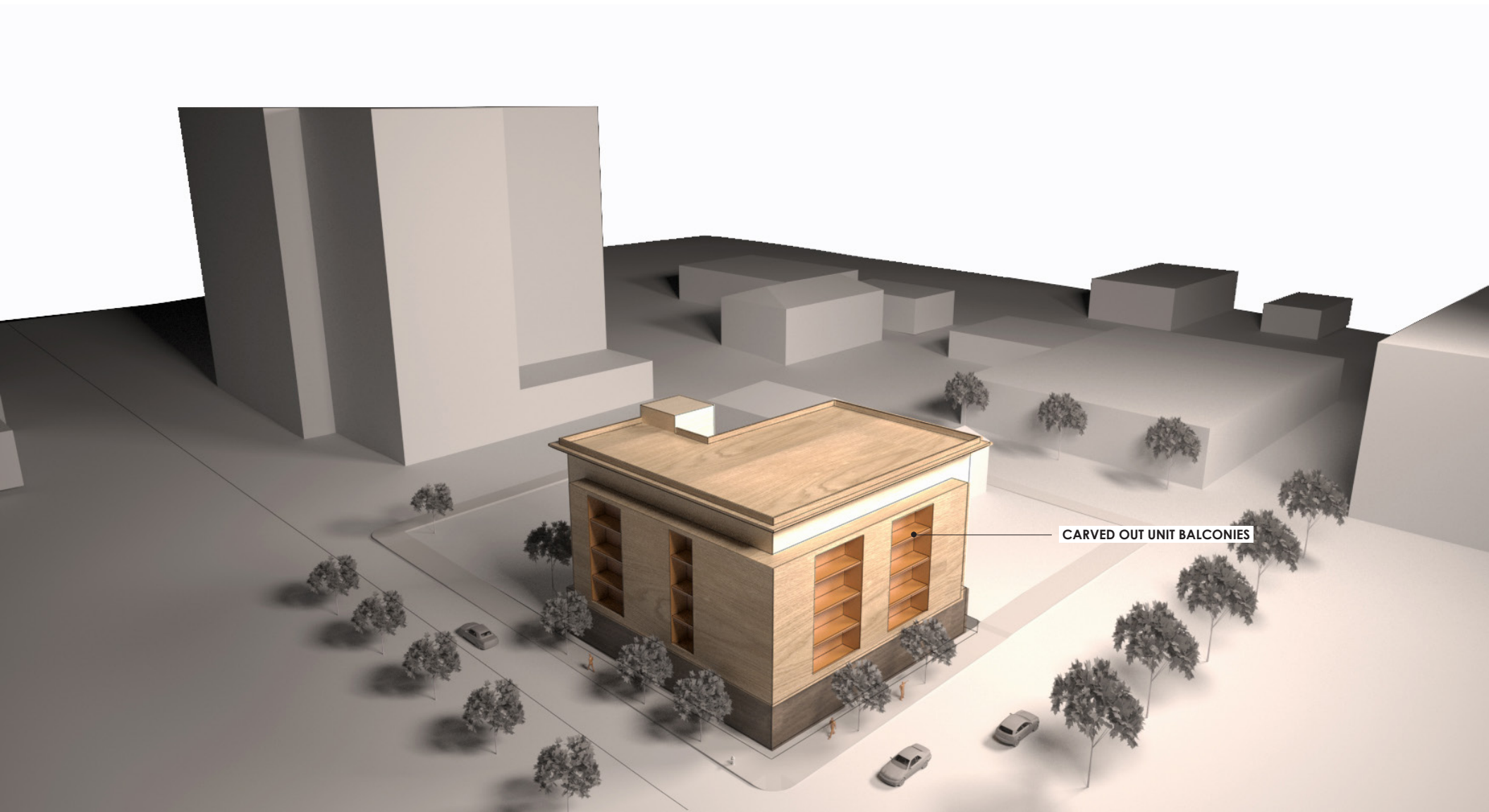

MASSING DIAGRAM

MIRACLES CENTRAL



VIEW FROM SOUTHWEST

MIRACLES CENTRAL



VIEW FROM NORTHWEST

MIRACLES CENTRAL



VIEW FROM SOUTHEAST

MIRACLES CENTRAL



BIRD'S EYE VIEW OF COURTYARD

MIRACLES CENTRAL



REVIEW OF DESIGN COMMENTS

MASSING

- PRIMARY MASSING IS GOOD
- REDUCE BUILDING SETBACK AT NW AND SE CORNERS
- NEED A BETTER TERMINATION OF TOP FLOOR WITH REST OF MASSING
- SIMPLIFY FORM OF TOP FLOOR. FEWER INS/OUTS. MATCH MASSING DIAGRAM
- LOOK INTO LARGER AND MORE REGULAR WINDOW OPENINGS AT SW CORNER
- BUILDING ENTRIES ARE TOO RECESSED AND THERE ARE TOO MANY INS/OUTS



VIEW FROM SOUTHWEST - OLD

MIRACLES CENTRAL



VIEW FROM NORTHWEST - OLD

MIRACLES CENTRAL



VIEW FROM SOUTHEAST - OLD

MIRACLES CENTRAL



GROUND FLOOR PLAN - NEW



GROUND FLOOR PLAN - OLD

GROUND FLOOR PLAN ADJUSTMENTS





SECOND FLOOR PLAN - NEW



SECOND FLOOR PLAN - OLD

TYPICAL FLOOR PLAN ADJUSTMENTS





SIXTH FLOOR PLAN - NEW

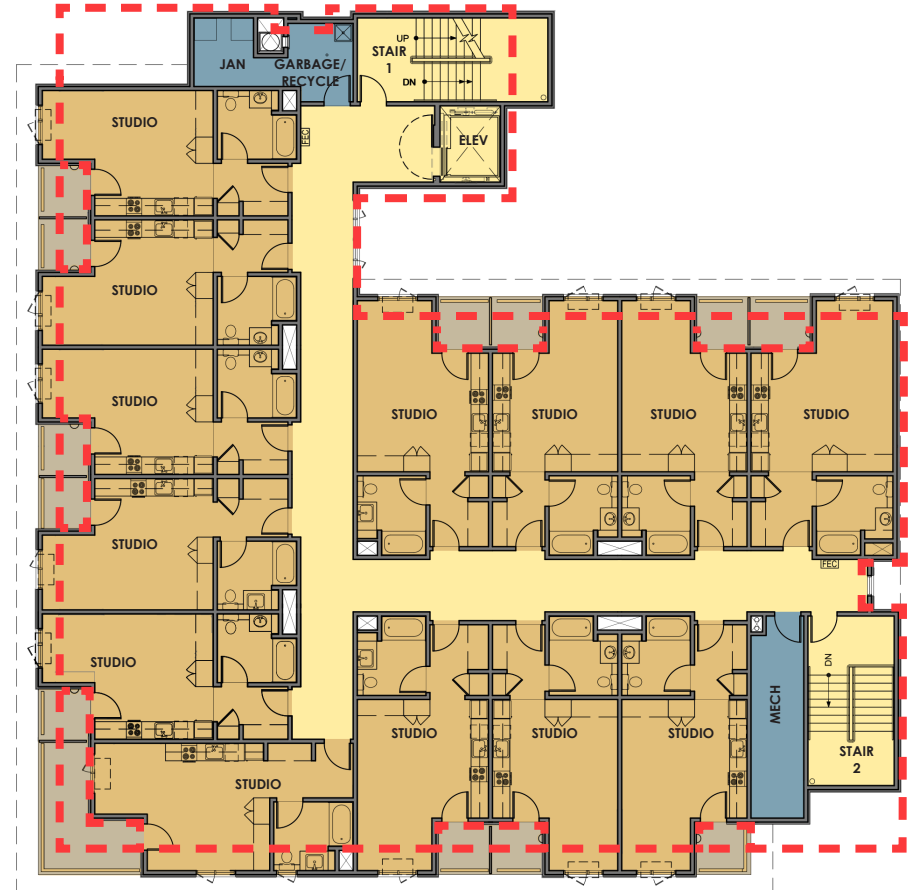

SIXTH FLOOR PLAN - OLD

SIXTH FLOOR PLAN ADJUSTMENTS



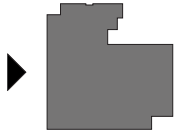

ELEVATION - WEST - OLD

MIRACLES CENTRAL



ELEVATION - WEST - NEW

MIRACLES CENTRAL





ELEVATION - SOUTH - OLD



ELEVATION - SOUTH - NEW

MIRACLES CENTRAL

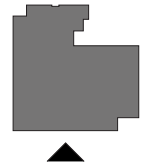

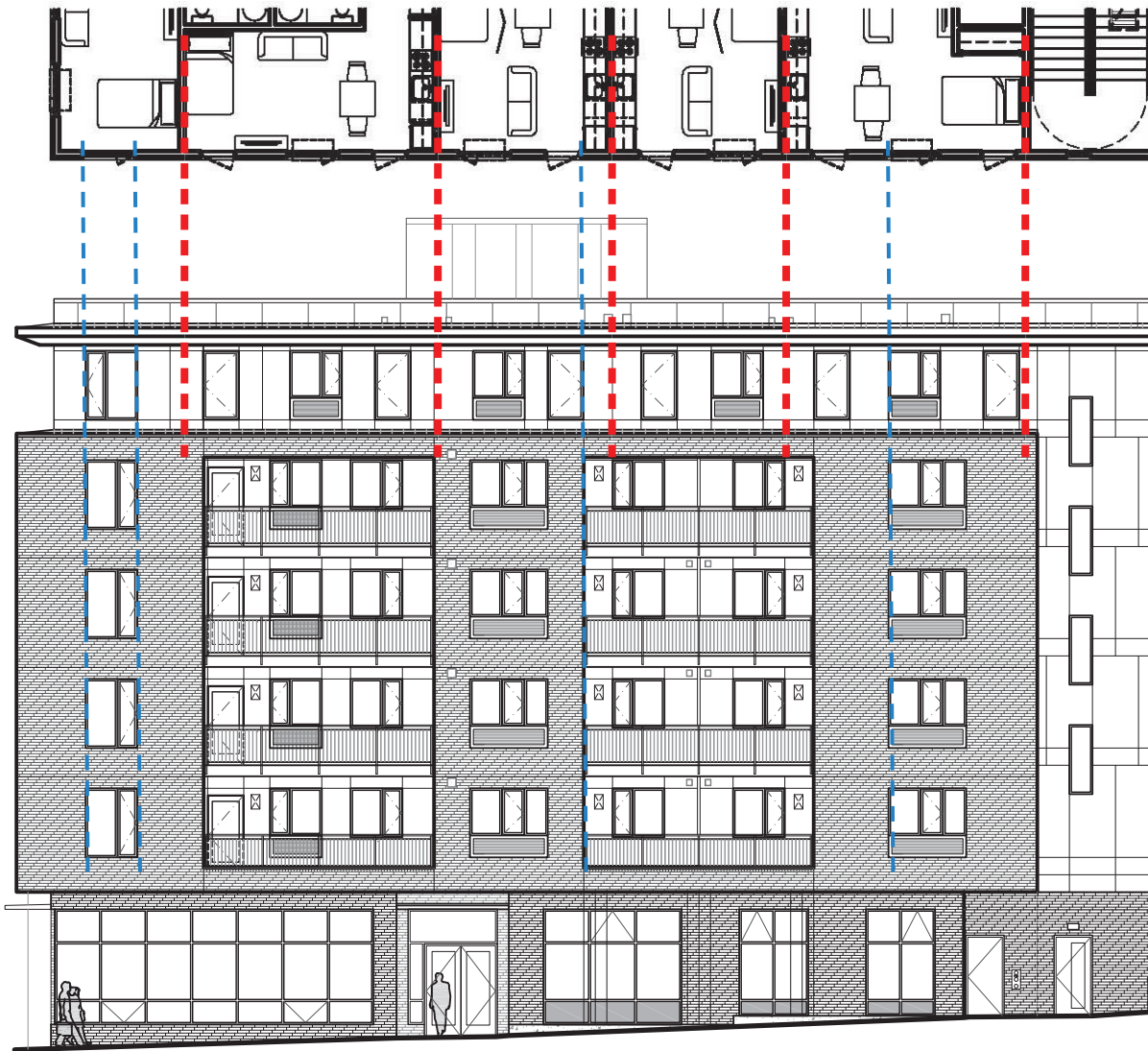

- - - - -
 UNIT DEMISING WALL
- - - - -
 WINDOW ALIGNMENT

SOUTH ELEVATION

WINDOW ALIGNMENT DIAGRAM

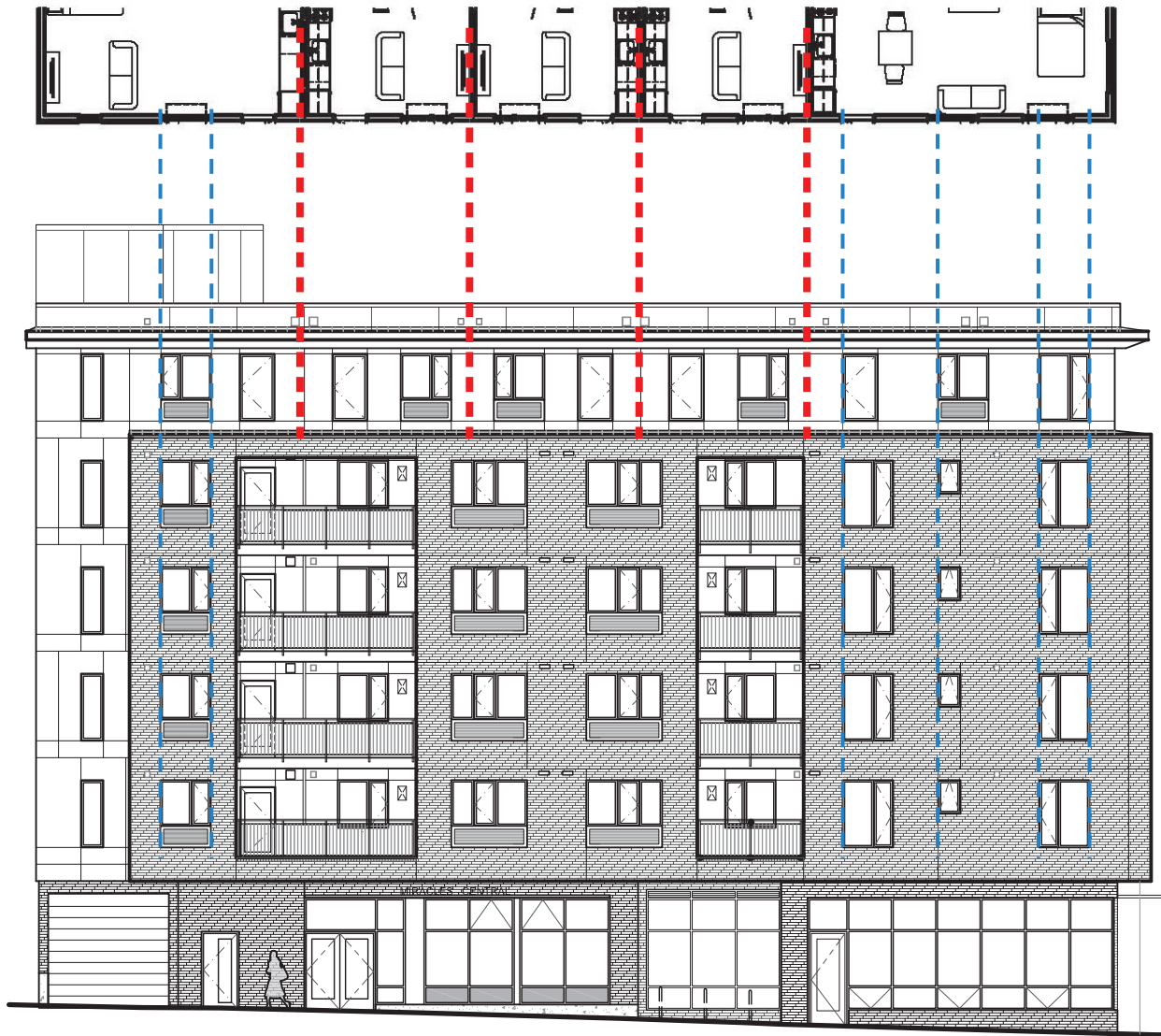

WEST ELEVATION

WINDOW ALIGNMENT DIAGRAM

- - - - -
 UNIT DEMISING WALL
- - - - -
 WINDOW ALIGNMENT

- A** LIGHT NORMAN BRICK
- B** DARK NORMAN BRICK
- C** PAINTED FIBER-CEMENT PANEL SIDING
- D** DARK BROWN VINYL WINDOWS
- E** PTHP WITH ARCHITECTURAL GRILLE
- F** PREFINISHED METAL & PAINTED FIBER-CEMENT PANEL
- G** PAINTED FIBER-CEMENT SOFFIT TO MATCH LIGHT BRICK
- H** PAINTED METAL BALCONY GUARDRAIL
- I** DARK BRONZE ALUMINUM STOREFRONT

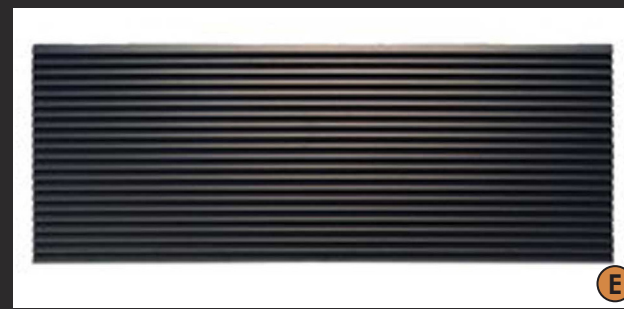
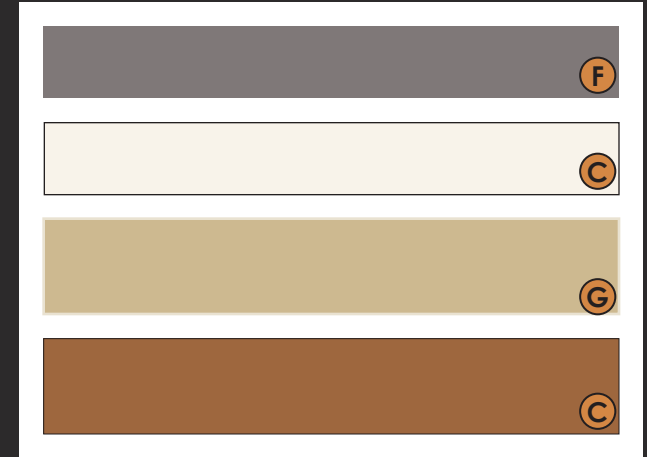

MATERIALS PALETTE

REVIEW OF DESIGN COMMENTS

MATERIALS

- QUIET DOWN STAIR TOWERS
- LAP SIDING IS NOT SUCCESSFUL. USE PANEL SIDING
- SIMPLIFY ENDS OF BUILDING. TOO MANY COLORS AND MATERIALS
- NO CONCRETE AT BASE. MAKE DARK BRICK CONTINUOUS ALONG STREET FACADES
- PROVIDE WINDOWS IN STAIRS



ELEVATION - SOUTH - OLD



UNIT BALCONIES

OMITTED LAP SIDING AT TOP FLOOR AND COMBINED WITH PANEL SIDING OF STAIR TOWERS

ADDED WINDOWS IN STAIRS

63'-0"

10 1/2"

COMMUNITY MEETING ROOM

MENTORING OFFICES

BRICK BASE NOW EXTENDS TO BUILDING EDGE

ELEVATION - SOUTH - NEW

MIRACLES CENTRAL

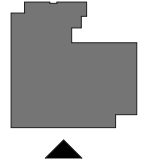



ELEVATION - NORTH - OLD

MIRACLES CENTRAL



NO LAP SIDING AT 6TH FLOOR. READS AS SIMPLER MASS

PRIMARY STAIR & ELEVATOR MASSING SIMPLIFIED AND NOW MERGED INTO LARGER MASSING. NO LONGER A DIFFERENT COLOR

SIMPLIFIED MATERIAL PALETTE AT BUILDING ENDS

63'-0"

RECESSED LANDSCAPE COURTYARD (BEYOND)

LOADING AREA NOW ENCLOSED IN BUILDING. LESS SETBACK IN THIS AREA REINFORCES THE SIMPLER MASSING AND STRONGER STREET PRESENCE

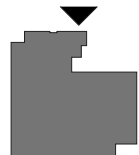

ELEVATION - NORTH - NEW

MIRACLES CENTRAL



ELEVATION - EAST - OLD

MIRACLES CENTRAL

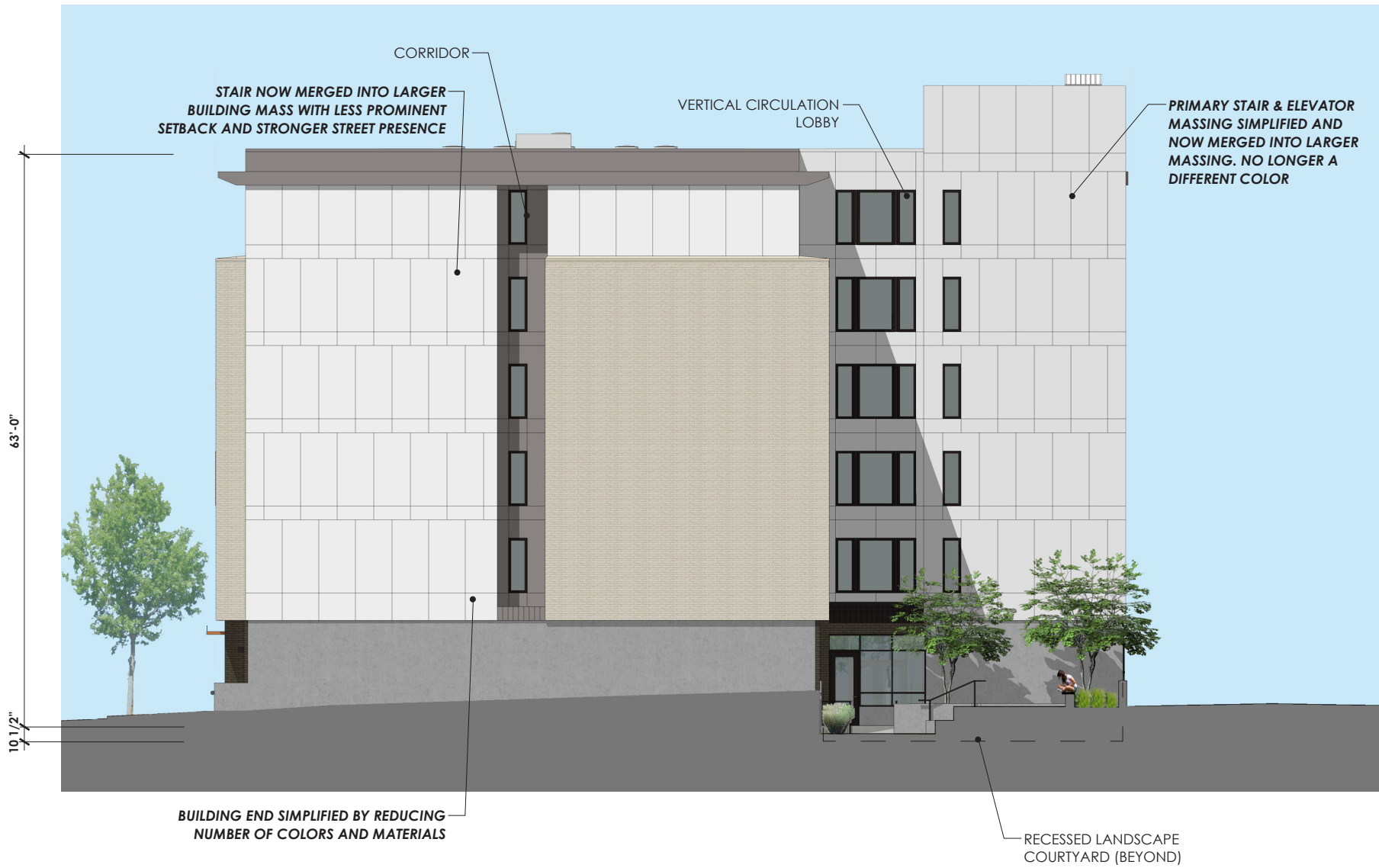

ELEVATION - EAST - NEW

MIRACLES CENTRAL

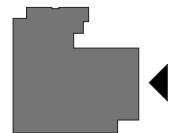

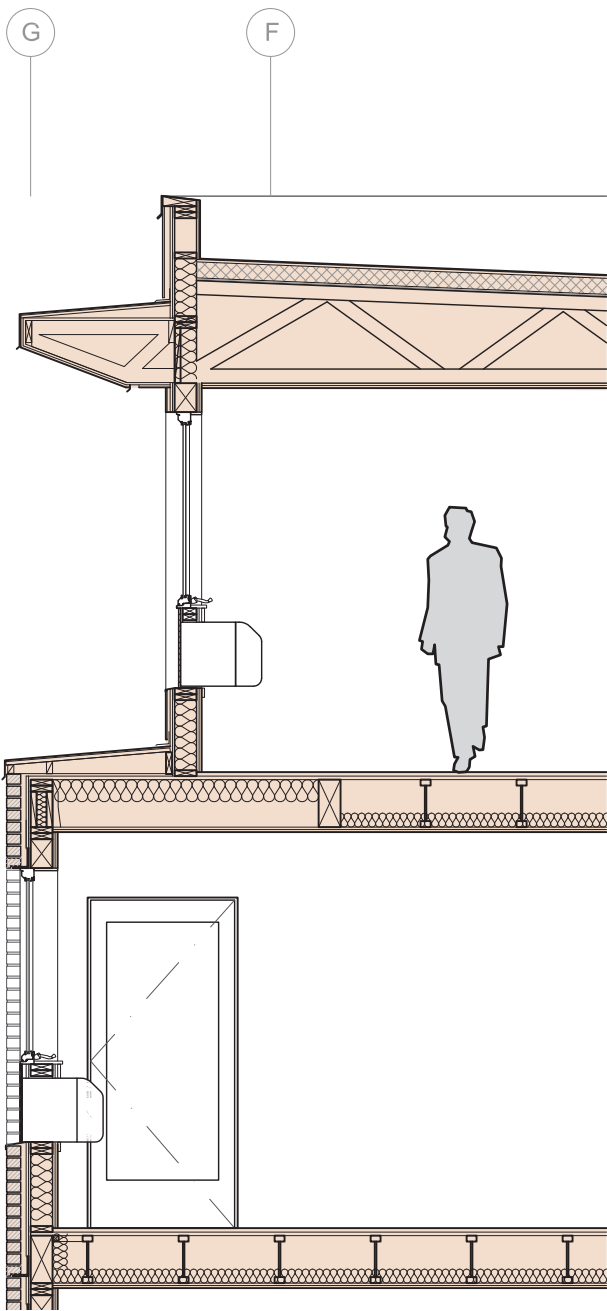

ENLARGED WALL SECTION



METAL CORNICE

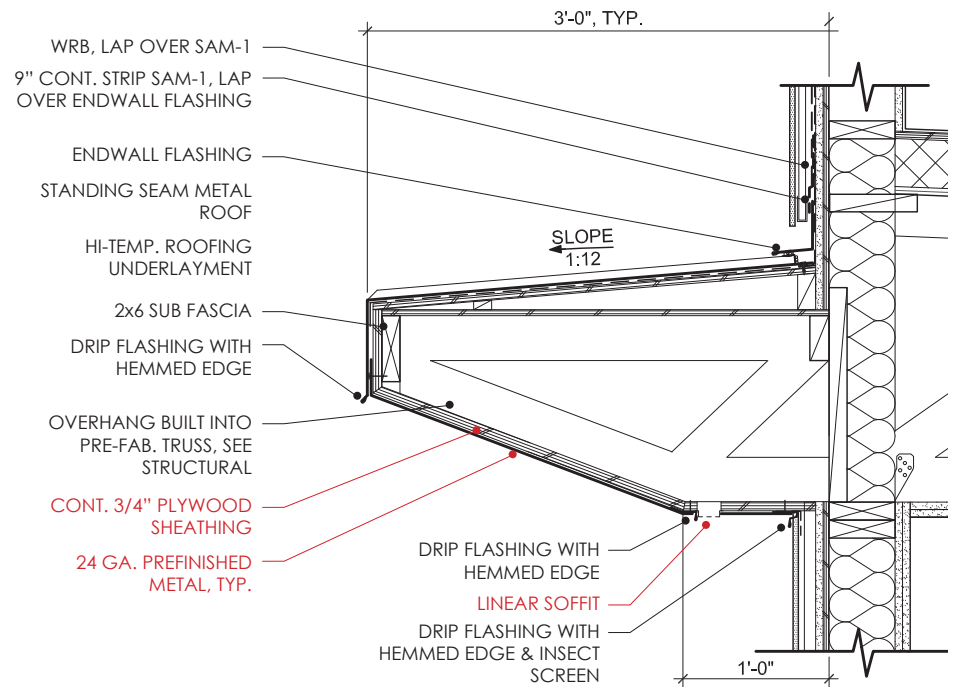

METAL EAVE SECTION



CLOSE UP OF METAL CORNICE



CLOSE-UP OF BALCONY RAILING



BALCONY REFERENCE

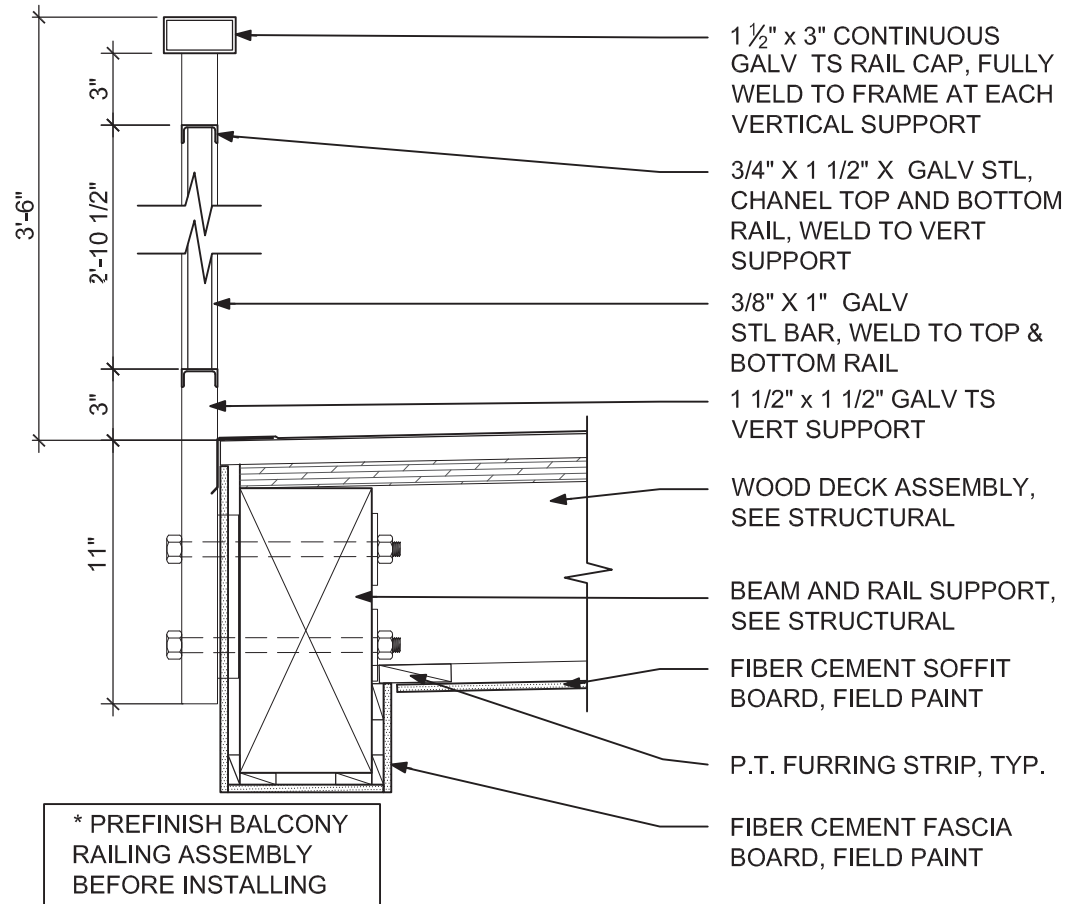

BALCONY RAILING SUPPORT



BALCONY RAILING



ELEVATION - WEST - NEW

MIRACLES CENTRAL

REVIEW OF DESIGN COMMENTS

GROUND FLOOR

- RESIDENTIAL ENTRANCE SHOULD BE LARGER AND EASIER TO IDENTIFY
- STRENGTHEN LINE OF SIGHT TO COURTYARD FROM RESIDENTIAL ENTRANCE
- PROVIDE BETTER PEDESTRIAN WEATHER PROTECTION
- BETTER UNIFY GROUND FLOOR WINDOWS



ELEVATION - WEST - OLD

MIRACLES CENTRAL



ELEVATION - WEST - NEW

MIRACLES CENTRAL



ELEVATION - SOUTH - OLD



UNIT BALCONIES

63'-0"

10' 1/2"

COMMUNITY MEETING ROOM
 RAISED PLANTER WITH SEATING
 RECESSED BENEATH OVERHANG

OFFICE ENTRY READS MORE
 PROMINENTLY WITH BRIGHTER
 COLOR

MENTORING OFFICES
 WINDOW MULLIONS NOW READ
 CONSISTENTLY ON GROUND
 FLOOR FACADES

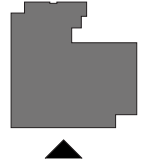

ELEVATION - SOUTH - NEW

MIRACLES CENTRAL

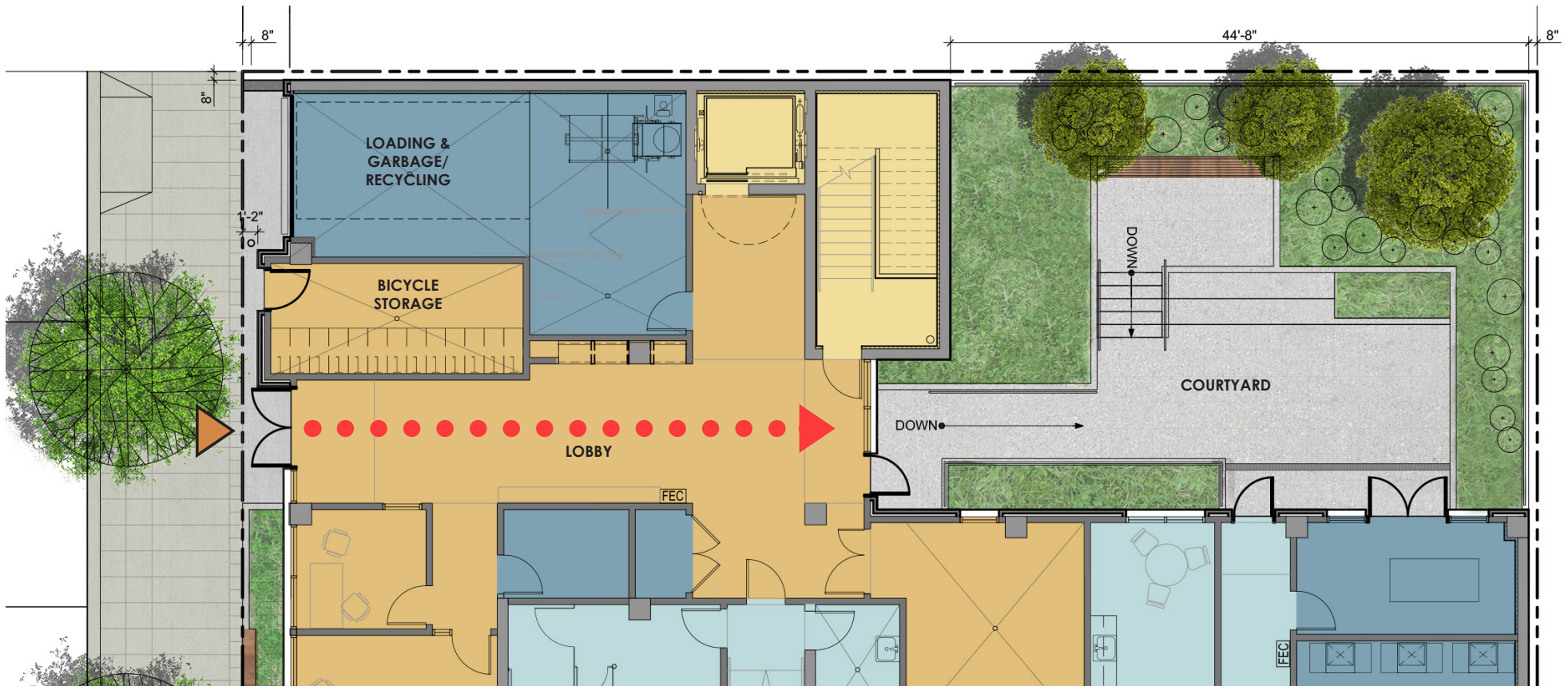

VIEW OF COURTYARD FROM ENTRANCE

GROUND FLOOR PLAN

MIRACLES CENTRAL



VIEW FROM SOUTHWEST - OLD

MIRACLES CENTRAL



VIEW FROM SOUTHWEST - NEW

MIRACLES CENTRAL



VIEW FROM NORTHWEST - OLD

MIRACLES CENTRAL



VIEW FROM NORTHWEST - NEW

MIRACLES CENTRAL



VIEW FROM SOUTHEAST - OLD

MIRACLES CENTRAL



VIEW FROM SOUTHEAST - NEW

MIRACLES CENTRAL



BIRD'S EYE VIEW OF COURTYARD - OLD

MIRACLES CENTRAL



BIRD'S EYE VIEW OF COURTYARD - NEW

MIRACLES CENTRAL



RESIDENTIAL ENTRANCE PEDESTRIAN PERSPECTIVE - OLD



RESIDENTIAL ENTRANCE PEDESTRIAN PERSPECTIVE - NEW



COMMUNITY ROOM PEDESTRIAN PERSPECTIVE - OLD



COMMUNITY ROOM PEDESTRIAN PERSPECTIVE - NEW

MODIFICATIONS

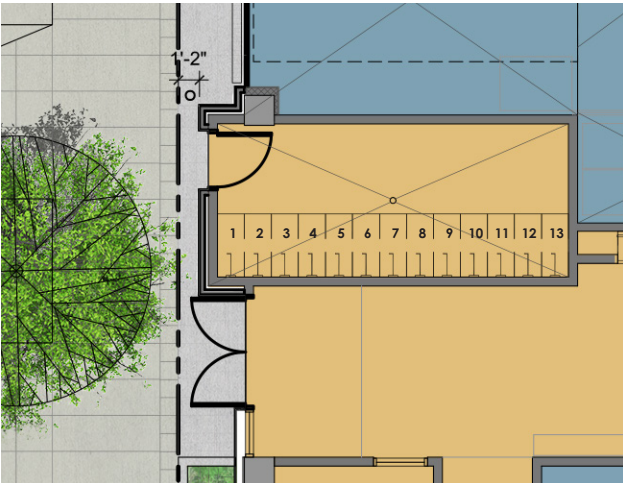

**BICYCLE PARKING AT GROUND FLOOR
LONG-TERM**

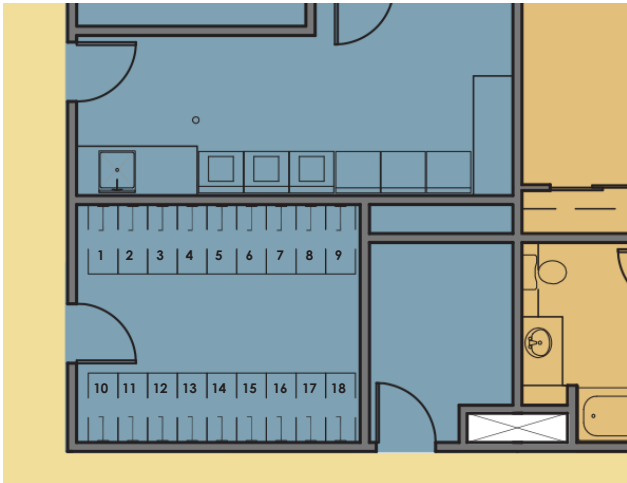

BICYCLE STORAGE AT 3RD & 5TH FLOOR

- LONG TERM BICYCLE STORAGE ROOM ON FLOOR 1, 3, 5 AND 1 & 2 BEDROOM APARTMENTS - 73 SPACES
- 6 SHORT TERM SPACES
- REQUEST A MODIFICATION TO DIMENSION OF LONG TERM BIKE SPACES TO PROVIDE STAGGERED WALL MOUNT RACKS
- REQUEST MODIFICATION TO SHORT TERM LOCATION - SPACES ARE GROUPED IN AN ALCOVE BETWEEN BOTH ENTRANCES. 25' TO PRIMARY BUILDING ENTRANCE. 68' TO SECONDARY ENTRANCE.

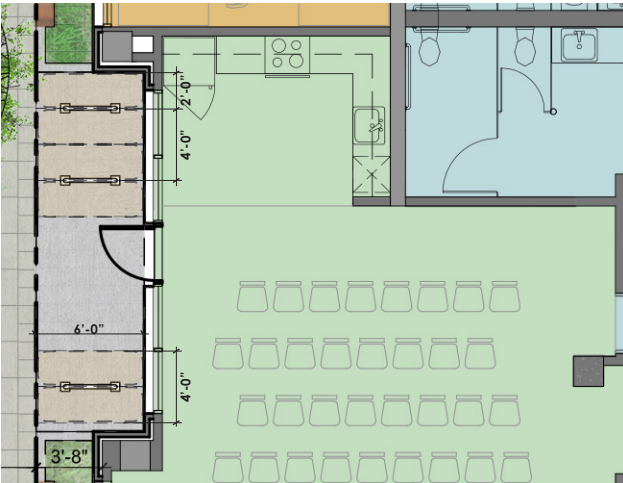

**BICYCLE PARKING AT GROUND FLOOR
SHORT-TERM**

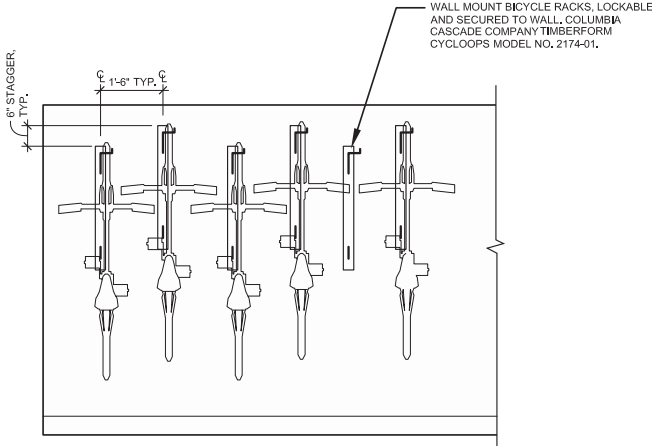

BICYCLE STORAGE ROOM ELEVATION



REFERENCE IMAGE

BICYCLE STORAGE



MIRACLES CENTRAL DESIGN REVIEW

10.16.2014