

0 E

D

C

B

A

0

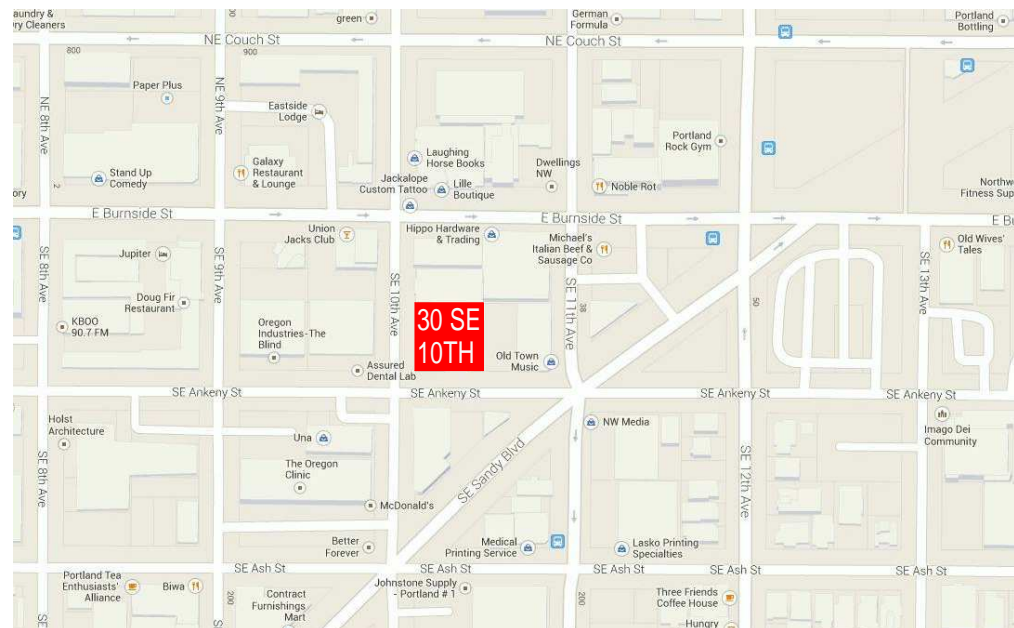

LOWER BURNSIDE LOFTS

DESIGN REVIEW SET
 SUBMITTED 09.30.2013
 UPDATED 12.11.2013

DRAWING LIST

C1	COVER	C14	LEVEL 1 RCP	C29	EXTERIOR DETAILS
C2	PLAN DIAGRAMS	C15	ELEVATION - WEST	C30	EXTERIOR DETAILS
C3	WALL AREA DIAGRAMS	C16	ELEVATION - SOUTH	C31	EXTERIOR DETAILS
C4	UTILITY PLAN	C17	ELEVATION - EAST	C32	EXTERIOR DETAILS
C4.1	UTILITY PLAN	C18	ELEVATION - NORTH	C33	EXTERIOR DETAILS
C5	LANDSCAPING	C19	BUILDING SECTION	C34	MATERIALS
C6	LANDSCAPING	C20	BUILDING SECTION	C35	MASSING CONCEPT
C7	LEVEL 1	C21	WALL SECTIONS	C36	PERSPECTIVE - SW
C8	LEVEL 2	C22	WALL SECTIONS	C37	PERSPECTIVE - NW
C9	LEVEL 3	C23	ENLARGED ELEVATIONS	C38	PERSPECTIVE - NE
C10	LEVEL 4	C24	ENLARGED ELEVATIONS	C39	PERSPECTIVE - SE
C11	LEVEL 5	C25	ENLARGED ELEVATIONS	C40	PERSPECTIVE - RETAIL FROM SE
C12	LEVEL 6	C26	ENLARGED ELEVATIONS	C41	PERSPECTIVE - GARAGE ENTRY
C13	ROOF	C27	ENLARGED ELEVATIONS	C42	PERSPECTIVE - S
		C28	NE COURTYARD	C43	PERSPECTIVE - W



VALLASTER CORL ARCHITECTS, PC
 711 SW ALDER
 PENTHOUSE SUITE
 PORTLAND, OR 97205
 PHONE : 503.228.0311
 FAX : 503.228.0314
 www.vcarch.com

1

1

2

2



OWNER :
 LOWER BURNSIDE LOFTS, LLC.

PROJECT NAME :
LOWER BURNSIDE LOFTS
 30 SE 10TH

REVISIONS :

ISSUE DATES :

FOR PERMIT (01.09.2014)

JOB NO. :	1303
DRAWN :	Author
CHECKED :	Checker
STATUS :	PERMIT

COVER
C1

3

3

4

4

5 E

D

C

B

A

5 ORIGINAL SHEET SIZE : 22"X34"



VALLASTER CORL ARCHITECTS, PC
 711 SW ALDER
 PENTHOUSE SUITE
 PORTLAND, OR 97205
 PHONE : 503.228.0311
 FAX : 503.228.0314
 www.vcarch.com

OWNER:
 LOWER BURNSIDE LOFTS, LLC.

PROJECT NAME:
LOWER BURNSIDE LOFTS
 30 SE 10TH

REVISIONS:

ISSUE DATES:
 FOR PERMIT (01.09.2014)

JOB NO.: 1303
 DRAWN: Author
 CHECKED: Checker
 STATUS: PERMIT

PLAN DIAGRAMS

C2

ORIGINAL SHEET SIZE : 22"x34"

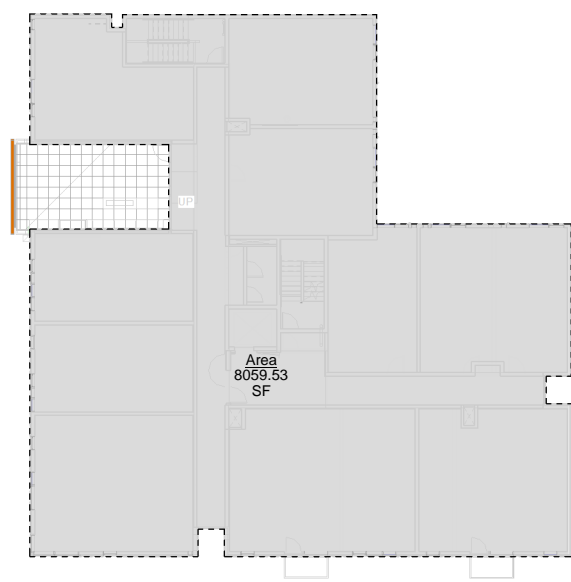

⑤ LEVEL 6
 1/16" = 1'-0"

BUILDING AREA

LEVEL 1	9338.36 SF
LEVEL 2	8455.59 SF
LEVEL 3	8499.34 SF
LEVEL 4	8505.75 SF
LEVEL 5	8561.59 SF
LEVEL 6	8059.53 SF
Grand total: 6	51420.16 SF

SITE AREA = 100' X 100' = 10,000 S.F.

FAR ACTUAL = 51420.16 / 10,000 S.F. = 5.1:1

FAR ALLOWED = 6:1

SITE COVERAGE: 100%

PARKING SPACES : 17 TOTAL LONG TERM (INCLUDING 1 ACCESSIBLE)
 0 REQUIRED

RESIDENTIAL UNIT COUNT:

STUDIOS :	13
1 BEDROOM :	41
2 BEDROOM :	8
TOTAL :	62 UNITS

BIKE PARKING :

BIKE ROOM:	40 SPACES
UNIT BIKE PARKING :	61 SPACES
TOTAL LT BIKE PARKING:	101 SPACES

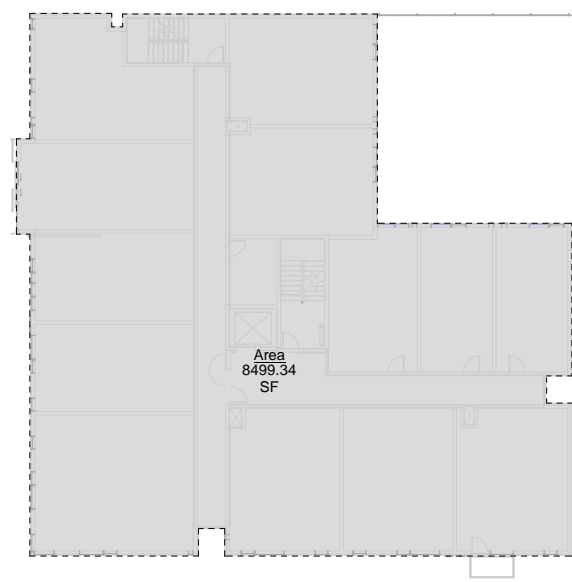

③ LEVEL 3
 1/16" = 1'-0"

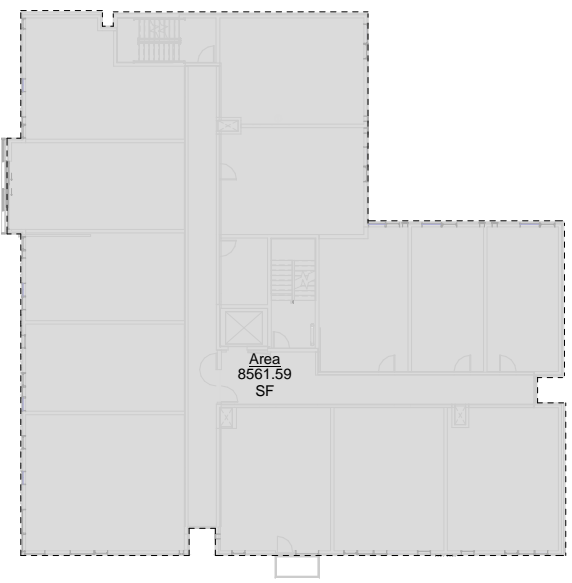

④ LEVEL 5
 1/16" = 1'-0"

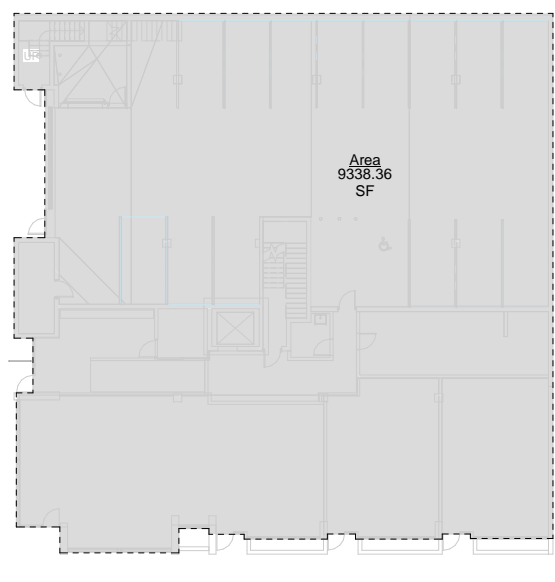

① LEVEL 1
 1/16" = 1'-0"

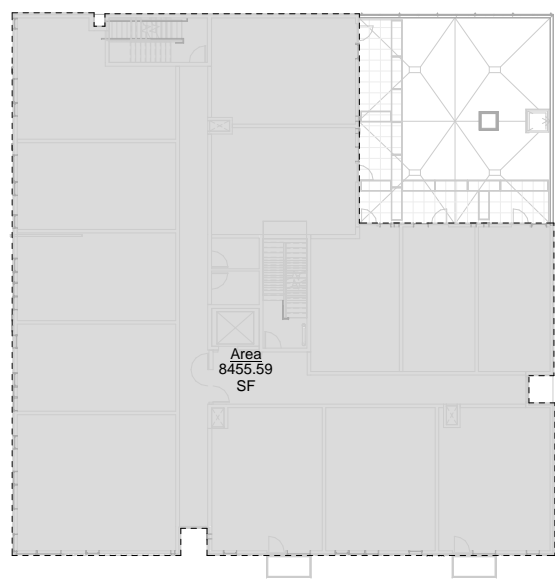

② LEVEL 2
 1/16" = 1'-0"

o | E
1
2
3
4
5

| D

| C

| B

| A

o



VALLASTER CORL ARCHITECTS, PC
 711 SW ALDER
 PENTHOUSE SUITE
 PORTLAND, OR 97205
 PHONE : 503.228.0311
 FAX : 503.228.0314
 www.vcarch.com

OWNER :
 LOWER BURNSIDE LOFTS, LLC.

PROJECT NAME :
LOWER BURNSIDE LOFTS
 30 SE 10TH

REVISIONS :

ISSUE DATES :
 FOR PERMIT (01.09.2014)

JOB NO. : 1303
 DRAWN : Author
 CHECKED : Checker
 STATUS : PERMIT

WALL AREA DIAGRAMS

C3

ORIGINAL SHEET SIZE : 22"x34"

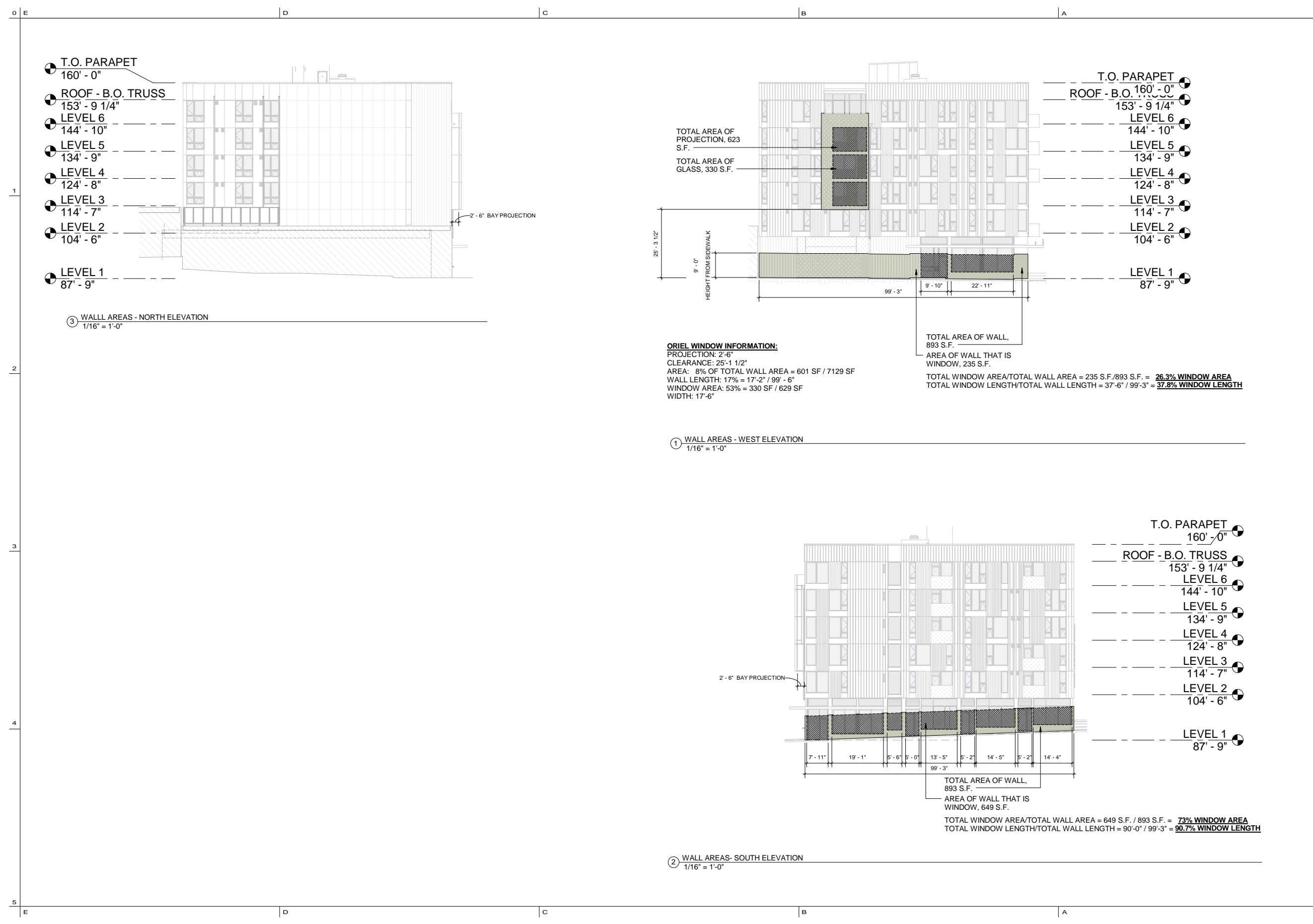

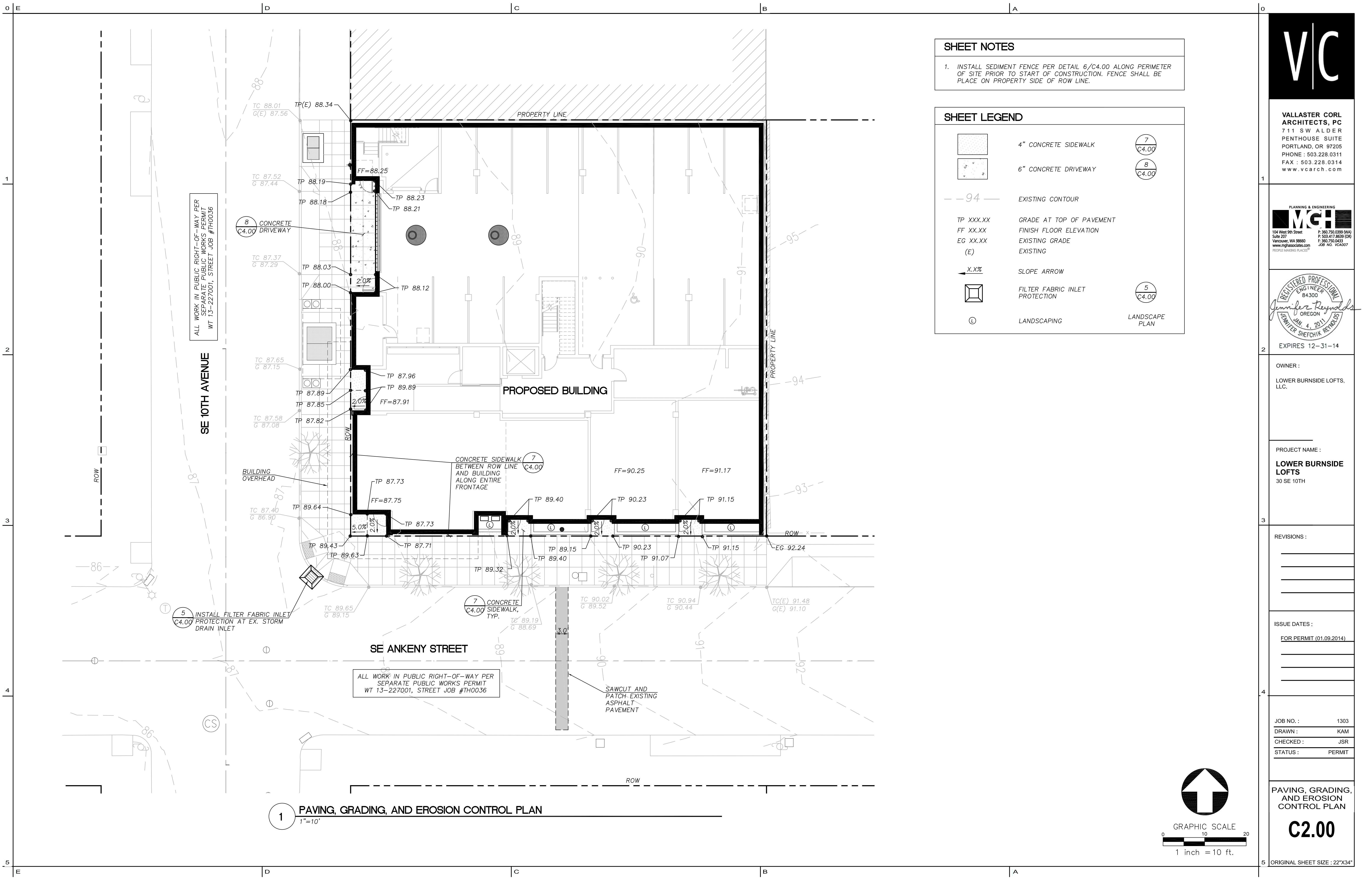

SHEET NOTES

- INSTALL SEDIMENT FENCE PER DETAIL 6/C4.00 ALONG PERIMETER OF SITE PRIOR TO START OF CONSTRUCTION. FENCE SHALL BE PLACE ON PROPERTY SIDE OF ROW LINE.

SHEET LEGEND

	4" CONCRETE SIDEWALK	
	6" CONCRETE DRIVEWAY	
	EXISTING CONTOUR	
TP XXX.XX	GRADE AT TOP OF PAVEMENT	
FF XX.XX	FINISH FLOOR ELEVATION	
EG XX.XX	EXISTING GRADE	
(E)	EXISTING	
	SLOPE ARROW	
	FILTER FABRIC INLET PROTECTION	
	LANDSCAPING	

ALL WORK IN PUBLIC RIGHT-OF-WAY PER SEPARATE PUBLIC WORKS PERMIT WT 13-227001, STREET JOB #TH0036

INSTALL FILTER FABRIC INLET PROTECTION AT EX. STORM DRAIN INLET

ALL WORK IN PUBLIC RIGHT-OF-WAY PER SEPARATE PUBLIC WORKS PERMIT WT 13-227001, STREET JOB #TH0036

1 PAVING, GRADING, AND EROSION CONTROL PLAN
1"=10'

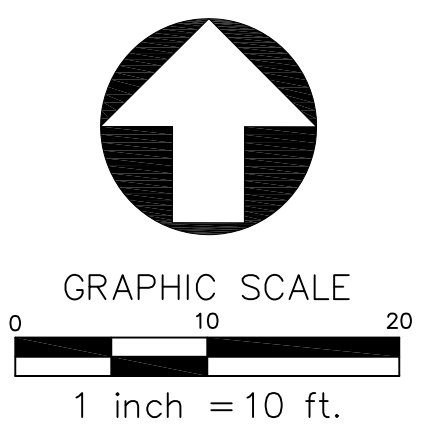

VIC

VALLASTER CORL ARCHITECTS, PC
711 SW ALDER
PENTHOUSE SUITE
PORTLAND, OR 97205
PHONE : 503.228.0311
FAX : 503.228.0314
www.vcarch.com

PLANNING & ENGINEERING

MGH

104 West 9th Street
Suite 207
Vancouver, WA 98660
www.mghassociates.com

P: 360.750.0399 (WA)
P: 503.477.8650 (OR)
F: 360.750.0433
JOB NO. VC4007

REGISTERED PROFESSIONAL ENGINEER
84300
Jennifer Reynolds
OREGON
JAN. 4, 2011
KIMBER SHEFCHIK REYNOLDS

EXPIRES 12-31-14

OWNER :
LOWER BURNSIDE LOFTS, LLC.

PROJECT NAME :
LOWER BURNSIDE LOFTS
30 SE 10TH

REVISIONS :

ISSUE DATES :
FOR PERMIT (01.09.2014)

JOB NO. : 1303
DRAWN : KAM
CHECKED : JSR
STATUS : PERMIT

PAVING, GRADING, AND EROSION CONTROL PLAN

C2.00

ORIGINAL SHEET SIZE : 22"x34"

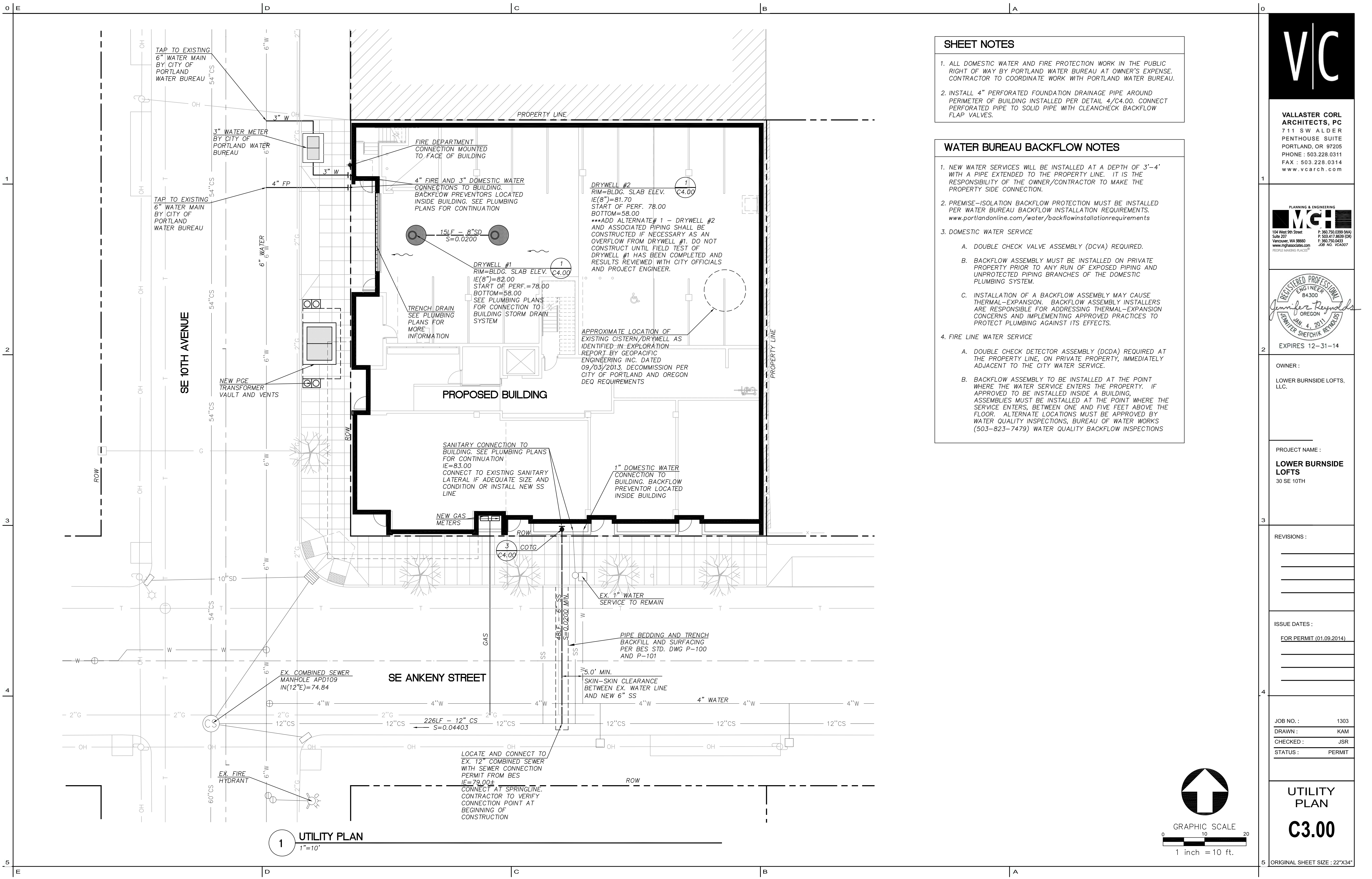

1 UTILITY PLAN
1"=10'

SHEET NOTES

1. ALL DOMESTIC WATER AND FIRE PROTECTION WORK IN THE PUBLIC RIGHT OF WAY BY PORTLAND WATER BUREAU AT OWNER'S EXPENSE. CONTRACTOR TO COORDINATE WORK WITH PORTLAND WATER BUREAU.
2. INSTALL 4" PERFORATED FOUNDATION DRAINAGE PIPE AROUND PERIMETER OF BUILDING INSTALLED PER DETAIL 4/C4.00. CONNECT PERFORATED PIPE TO SOLID PIPE WITH CLEANCHECK BACKFLOW FLAP VALVES.

WATER BUREAU BACKFLOW NOTES

1. NEW WATER SERVICES WILL BE INSTALLED AT A DEPTH OF 3'-4' WITH A PIPE EXTENDED TO THE PROPERTY LINE. IT IS THE RESPONSIBILITY OF THE OWNER/CONTRACTOR TO MAKE THE PROPERTY SIDE CONNECTION.
2. PREMISE-ISOLATION BACKFLOW PROTECTION MUST BE INSTALLED PER WATER BUREAU BACKFLOW INSTALLATION REQUIREMENTS. www.portlandonline.com/water/backflowinstallationrequirements
3. DOMESTIC WATER SERVICE
 - A. DOUBLE CHECK VALVE ASSEMBLY (DCVA) REQUIRED.
 - B. BACKFLOW ASSEMBLY MUST BE INSTALLED ON PRIVATE PROPERTY PRIOR TO ANY RUN OF EXPOSED PIPING AND UNPROTECTED PIPING BRANCHES OF THE DOMESTIC PLUMBING SYSTEM.
 - C. INSTALLATION OF A BACKFLOW ASSEMBLY MAY CAUSE THERMAL-EXPANSION. BACKFLOW ASSEMBLY INSTALLERS ARE RESPONSIBLE FOR ADDRESSING THERMAL-EXPANSION CONCERNS AND IMPLEMENTING APPROVED PRACTICES TO PROTECT PLUMBING AGAINST ITS EFFECTS.
4. FIRE LINE WATER SERVICE
 - A. DOUBLE CHECK DETECTOR ASSEMBLY (DCDA) REQUIRED AT THE PROPERTY LINE, ON PRIVATE PROPERTY, IMMEDIATELY ADJACENT TO THE CITY WATER SERVICE.
 - B. BACKFLOW ASSEMBLY TO BE INSTALLED AT THE POINT WHERE THE WATER SERVICE ENTERS THE PROPERTY. IF APPROVED TO BE INSTALLED INSIDE A BUILDING, ASSEMBLIES MUST BE INSTALLED AT THE POINT WHERE THE SERVICE ENTERS, BETWEEN ONE AND FIVE FEET ABOVE THE FLOOR. ALTERNATE LOCATIONS MUST BE APPROVED BY WATER QUALITY INSPECTIONS, BUREAU OF WATER WORKS (503-823-7479) WATER QUALITY BACKFLOW INSPECTIONS

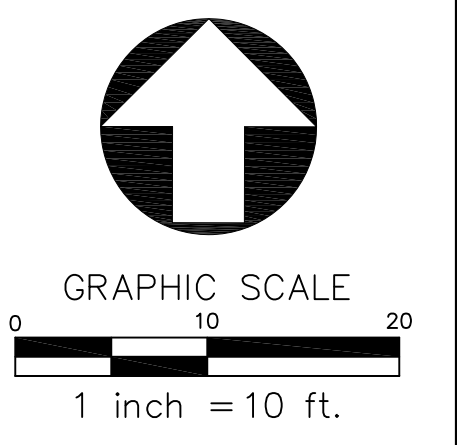

VIC

VALLASTER CORL ARCHITECTS, PC
 711 SW ALDER
 PENTHOUSE SUITE
 PORTLAND, OR 97205
 PHONE : 503.228.0311
 FAX : 503.228.0314
www.vcarch.com

PLANNING & ENGINEERING

MGH

104 West 9th Street
 Suite 207
 Vancouver, WA 98660
www.mghassociates.com

P: 360.750.0399 (WA)
 P: 503.477.8639 (OR)
 F: 360.750.0433
 JOB NO. VC4007

REGISTERED PROFESSIONAL ENGINEER
 84,300
Jennifer Reynolds
 OREGON
 JAN. 4, 2011
 PENNIFER SHEFCHIK REYNOLDS

EXPIRES 12-31-14

OWNER :
 LOWER BURNSIDE LOFTS, LLC.

PROJECT NAME :
LOWER BURNSIDE LOFTS
 30 SE 10TH

REVISIONS :

ISSUE DATES :

FOR PERMIT (01.09.2014)

JOB NO. : 1303
 DRAWN : KAM
 CHECKED : JSR
 STATUS : PERMIT

UTILITY PLAN

C3.00

ORIGINAL SHEET SIZE : 22"X34"

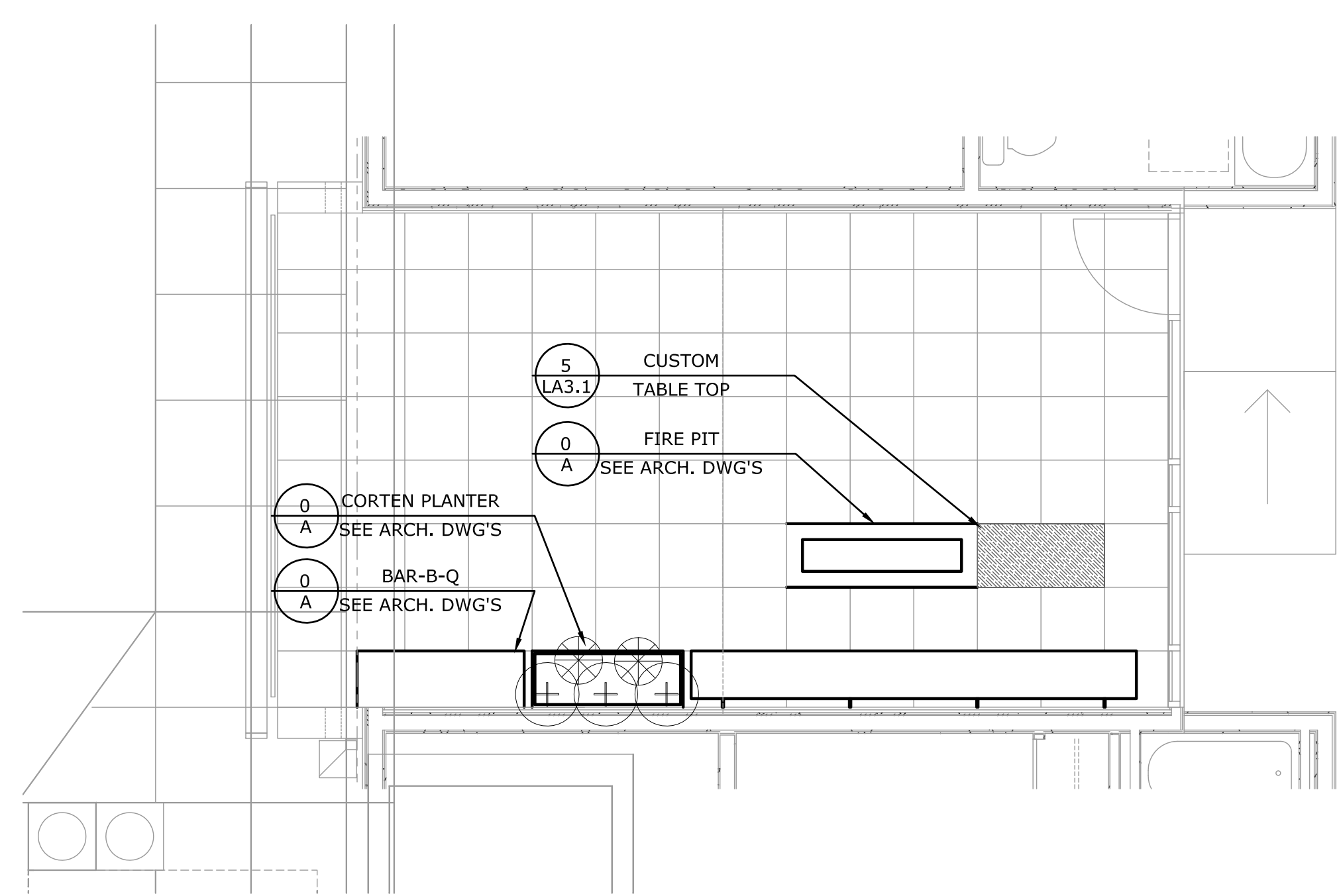

1 6th Floor Roof Deck - PLANTING PLAN
LA2.1 Scale: 1/4" = 1'-0"

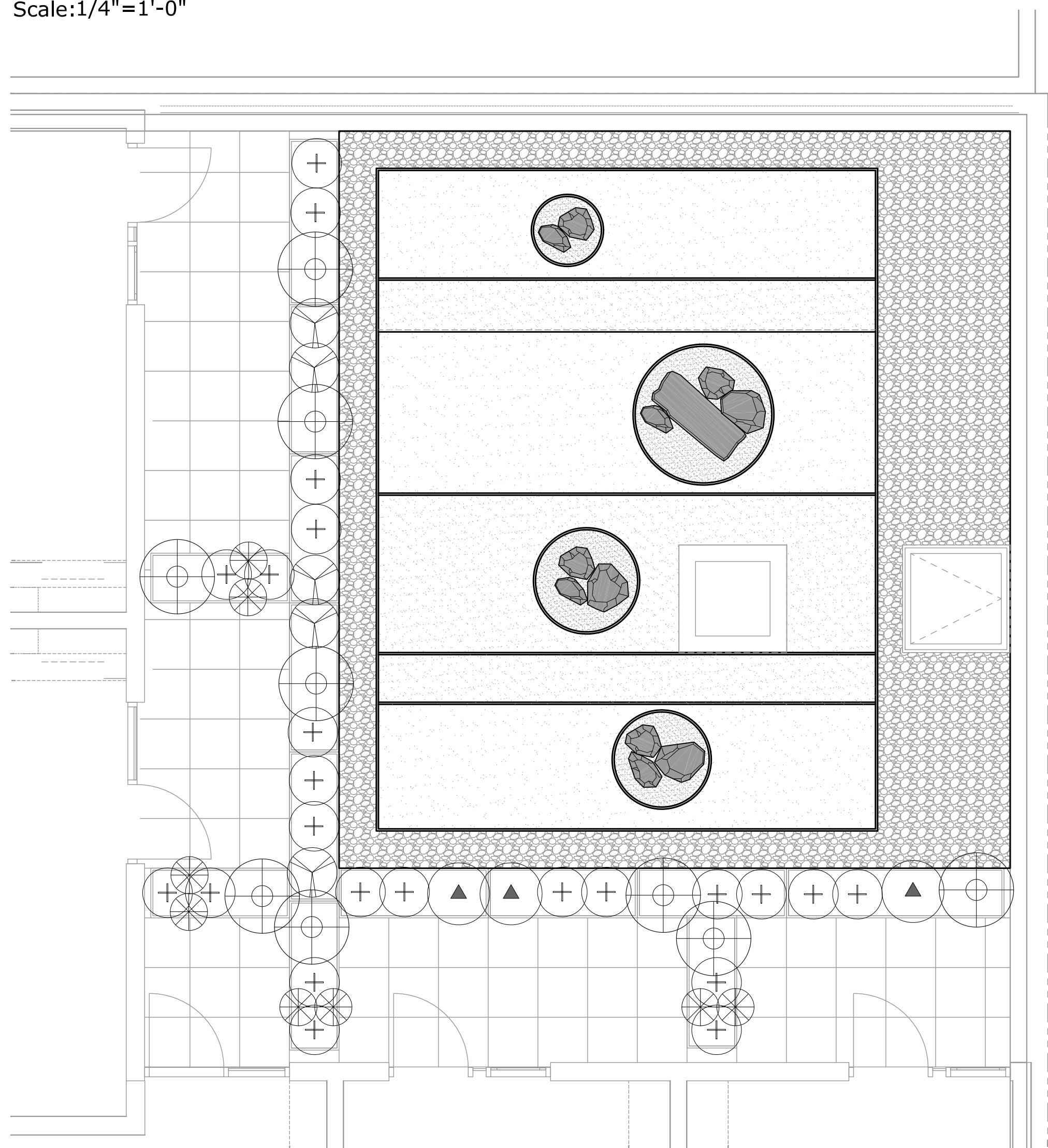

2 2nd. Floor Roof Deck - PLANTING PLAN
LA2.1 Scale: 1/4" = 1'-0"

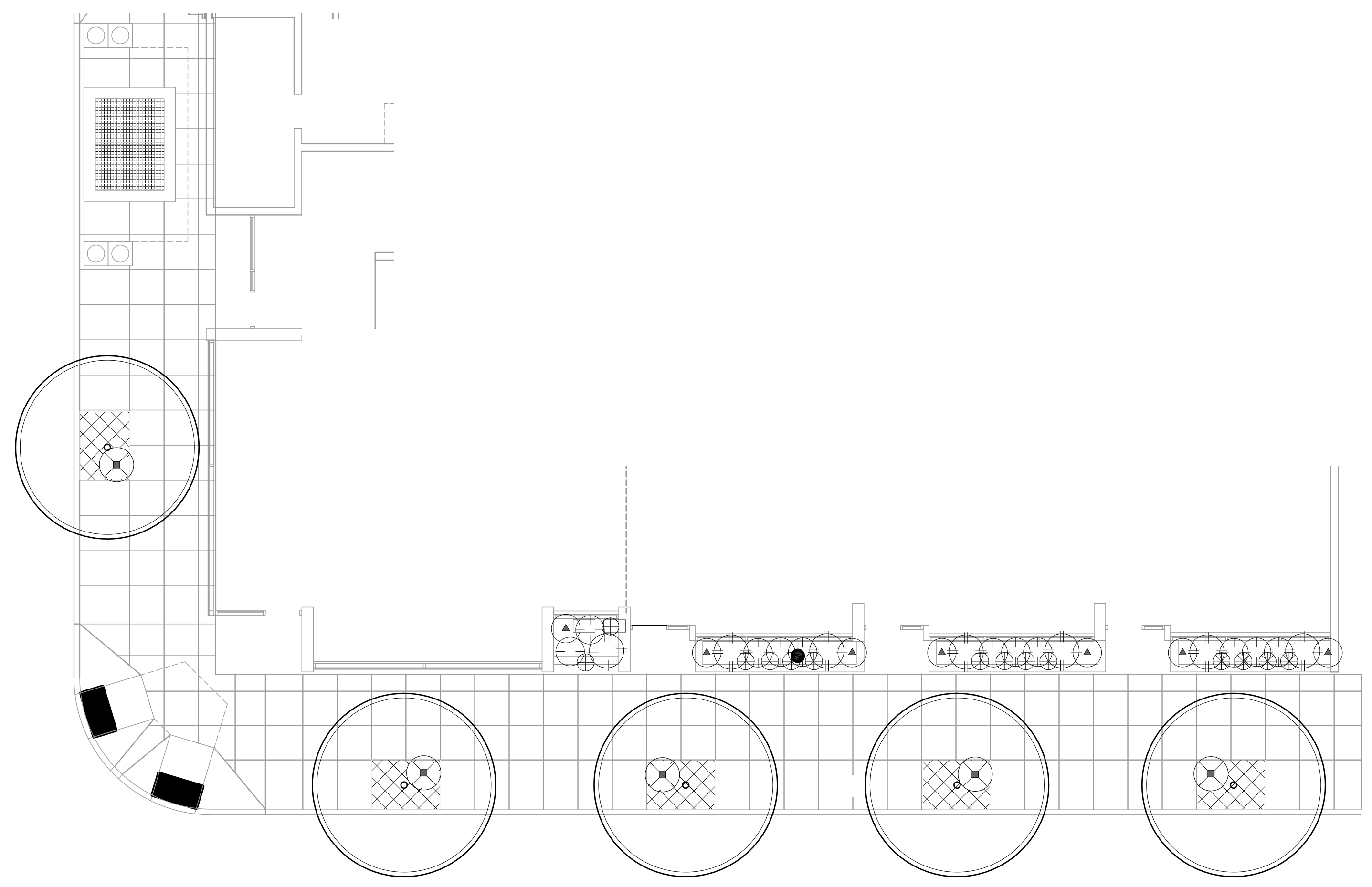

4 Street Level - PLANTING PLAN
LA2.1 Scale: 1/8" = 1'-0"

TREE SCHEDULE

SYM.	ABBR	BOTANICAL NAME	COMMON NAME	SIZE	QTY	DETAIL
⊙		Fraxinus americana 'Junginger'	Autumn Purple Ash	3" CALIPER	5	

SHRUB SCHEDULE

SYM.	BOTANICAL NAME	COMMON NAME	SIZE	SPACING	QTY	DETAIL
⊙	MISCANTHUS SINENSIS 'MORNING LIGHT'	MORNING LIGHT MAIDENGRASS	1 GAL.	PER PLAN	5	
⊕	NANDINA 'MONFAR'	SIENNA SUNRISE HEAVENLY BAMBOO	3 GAL.	PER PLAN	26	
⊕	LEUCOTHOE 'ZEBLID'	SCARLETTA FETTERBUSH	1 GAL.	PER PLAN	11	
⊕	VINCA MINOR 'VARIEGATA'	VARIEGATED PERIWINKLE	4" POT	PER PLAN	14	
⊕	CHOISYA TERNATA	MEXICAN ORANGE	5 GAL.	PER PLAN	9	
⊕	VIBURNUM DAVIDII	DAVIDII VIBURNUM	5 GAL.	PER PLAN	5	
⊕	SARCOCOCCA HOOKERIANA 'HUMILIS'	HIMALAYAN SWEET BOX	1 GAL.	PER PLAN	7	
⊕	HYDRANGEA MACROPHYLLA 'PARIS RAPA'	CITYLINE DWARF HYDRANGEA	5 GAL.	PER PLAN	10	
⊕	HAKONECHLOA MACRA 'AUREOLA'	JAPANESE FOREST GRASS	1 GAL.	PER PLAN	10	

GROUNDCOVER SCHEDULE

SYM.	BOTANICAL NAME	COMMON NAME	SIZE	SPACING	AREA	DETAIL
⊗	RUBUS CALYCINOIDES	CREEPING BRAMBLE	4" POTS	12" O.C.		

NOTE: ALL PLANTED AREAS TO RECEIVE AN AUTOMATIC IRRIGATION SYSTEM.

3 Planting Legend and Notes
LA2.1 Scale: N.T.S.



VALLASTER CORL ARCHITECTS, PC
711 SW ALDER
PENTHOUSE SUITE
PORTLAND, OR 97205
PHONE : 503.228.0311
FAX : 503.228.0314
www.vcarch.com

VC _{LA}
VALA-CHRISTENSEN
landscape architects
906 NW 23rd Avenue
Portland, OR 97210
503.504.2816

OWNER :
LOWER BURNSIDE LOFTS, LLC.

PROJECT NAME :
LOWER BURNSIDE LOFTS
30 SE 10TH

REVISIONS :

ISSUE DATES :

JOB NO. : Project Number
DRAWN : DAC
CHECKED : DAC
STATUS : DAR

LANDSCAPING

C5

ORIGINAL SHEET SIZE : 22"X34"

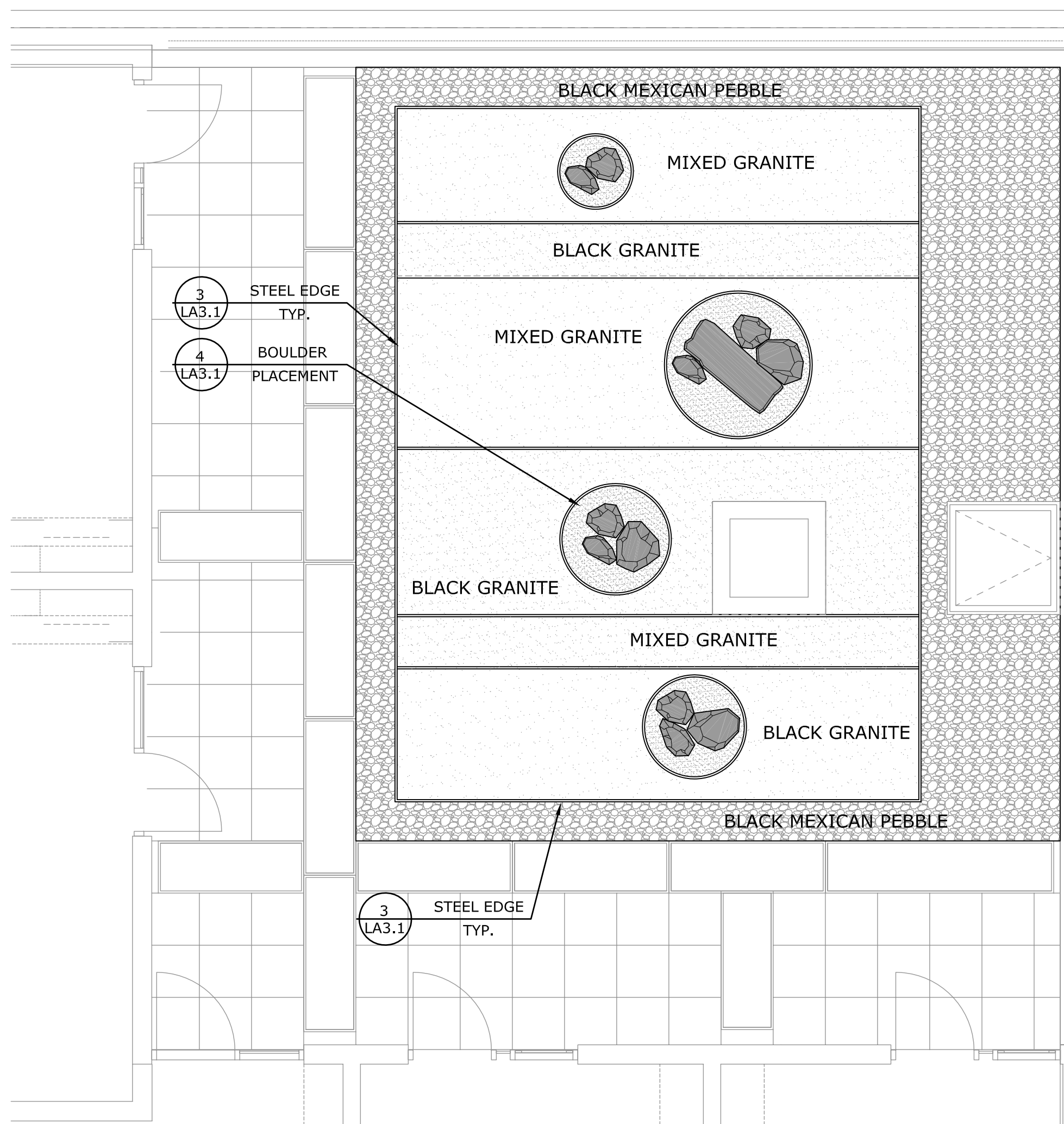

2 2nd. Floor Roof Deck - ROCK GARDEN PLAN
LA2.1 Scale:1/4"=1'-0"



COLUMBIA RIVER BASALT COLUMN ROCK

Hand selected by the Landscape Architect from the Corbet Oregon quarry site. Exact location of basalt on roof deck as directed by the Landscape Architect in the field. Contractor responsible for coordination of material to the site, crane in place, shim and mortar as needed to assure stable.



STONE SCHEDULE
2 Large Stone - 30"x60", to placed on side
6 Medium Stone - 24"x42"
8 Small Stone - 24"x24"



BLACK MEXICAN PEBBLE ROCK
Washed; 1"-2" in size.



BLACK CRUSHED GRANITE
Washed; 3/4"-1" in size.



BLACK CRUSHED GRANITE
Washed; 1/2"-3/4" in size.

2 2nd. Floor Roof Deck - MATERIALS
LA2.1 Scale:1/4"=1'-0"

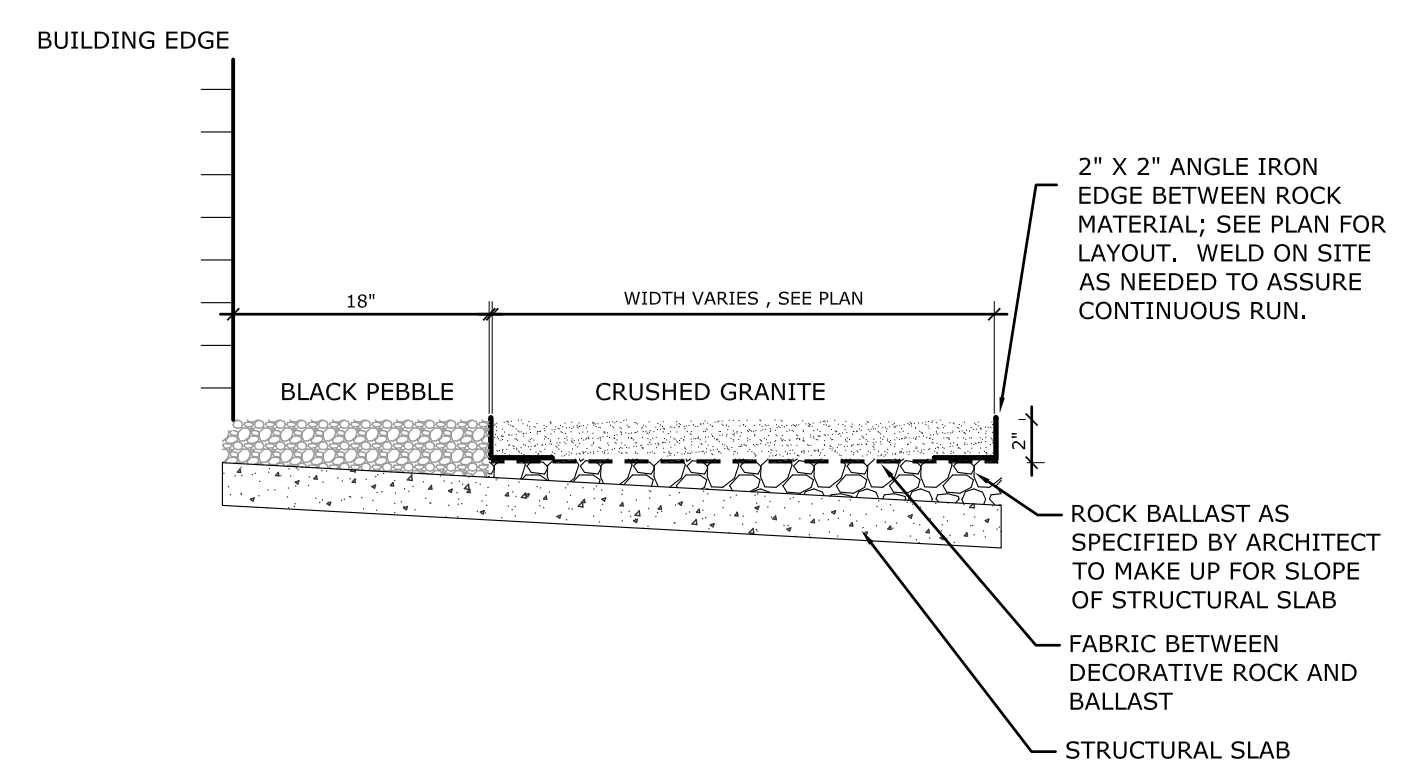

3 Steel Edge
LA2.1 Scale:3/4"=1'-0"

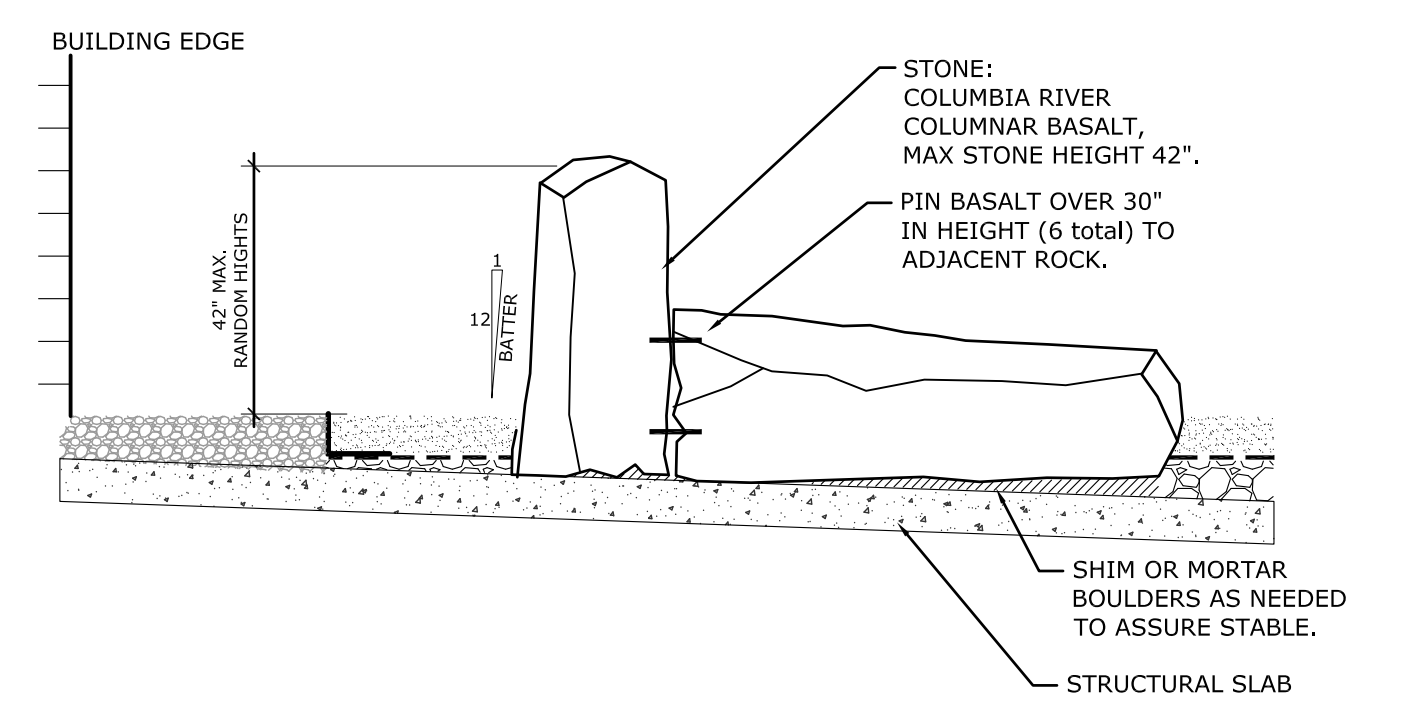

COLUMBIA RIVER BASALT COLUMN ROCK

Hand selected by the Landscape Architect from the Corbet Oregon quarry site. Exact location of basalt on roof deck as directed by the Landscape Architect in the field.

4 Boulder Placement
LA2.1 Scale:3/4"=1'-0"

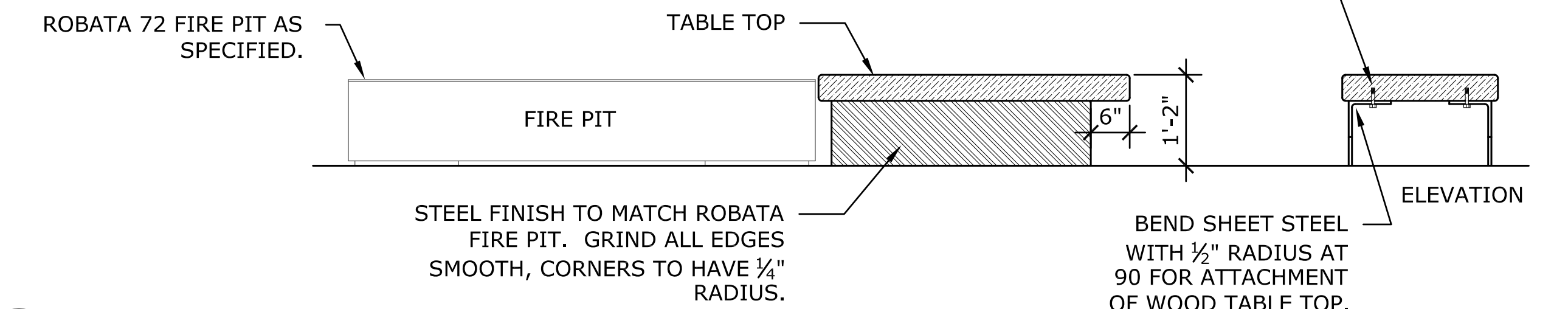
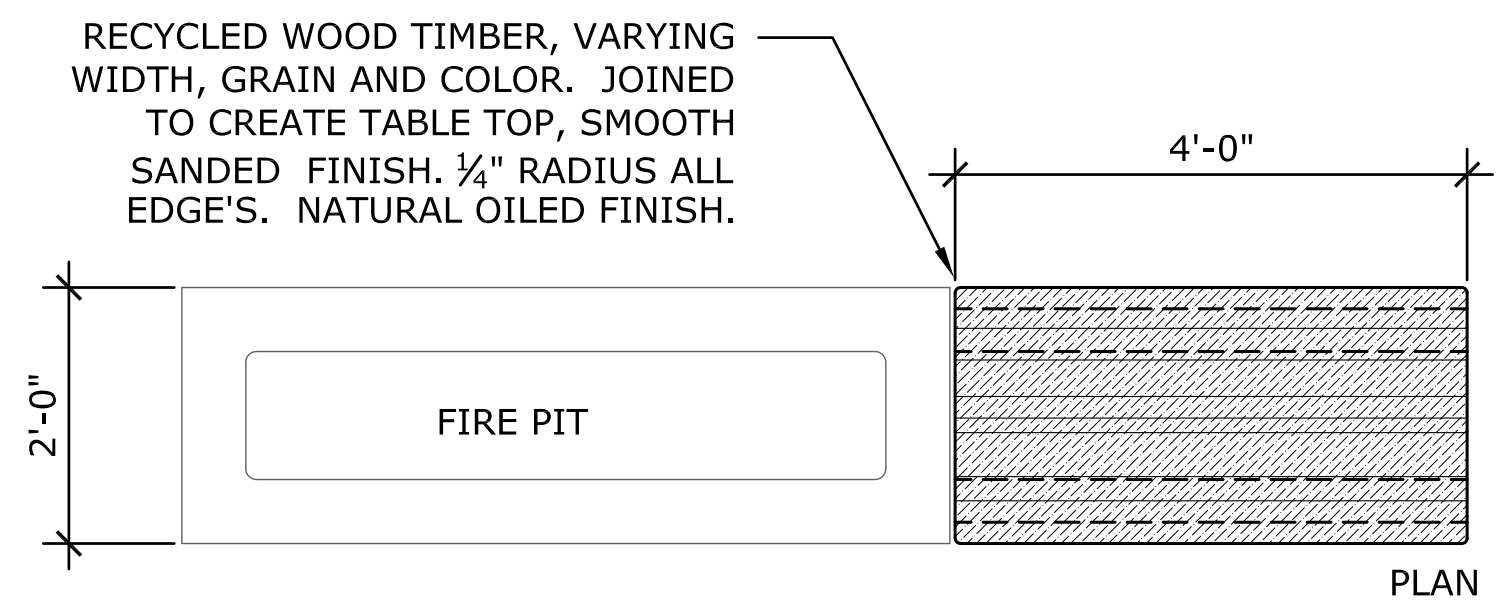

5 Table Top w/ Metal Legs
LA2.1 Scale:3/4"=1'-0"



VALLASTER CORL ARCHITECTS, PC
711 SW ALDER
PENTHOUSE SUITE
PORTLAND, OR 97205
PHONE : 503.228.0311
FAX : 503.228.0314
www.vcarch.com

VC la
VALA-CHRISTENSEN
landscape architects
906 NW 23rd. Avenue
Portland, OR 97210
503.504.2816

OWNER :
LOWER BURNSIDE LOFTS, LLC.

PROJECT NAME :
LOWER BURNSIDE LOFTS
30 SE 10TH

REVISIONS :

ISSUE DATES :

JOB NO. : Project Number
DRAWN : DAC
CHECKED : DAC
STATUS : DAR

LANDSCAPING
C6

ORIGINAL SHEET SIZE : 22"x34"

AREA CALCULATED :

- EXTERIOR FACE OF EXTERIOR WALL
- CORRIDOR FACE OF CORRIDOR WALL
- CENTERLINE OF DEMISING WALL

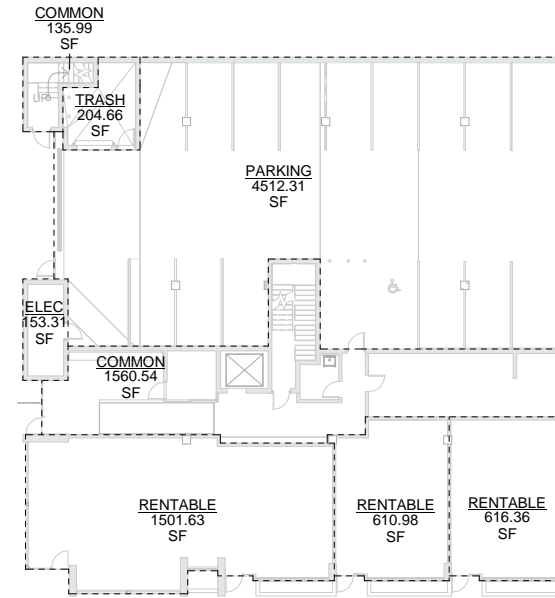

② LEVEL 1 AREA CALCULATIONS
1/16" = 1'-0"



VALLASTER CORL ARCHITECTS, PC
711 SW ALDER
PENTHOUSE SUITE
PORTLAND, OR 97205
PHONE : 503.228.0311
FAX : 503.228.0314
www.vcarch.com

OWNER :
LOWER BURNSIDE LOFTS, LLC.

PROJECT NAME :
LOWER BURNSIDE LOFTS
30 SE 10TH

REVISIONS :

ISSUE DATES :
FOR PERMIT (01.09.2014)

JOB NO. : 1303
DRAWN : Author
CHECKED : Checker
STATUS : PERMIT

LEVEL 1
C7

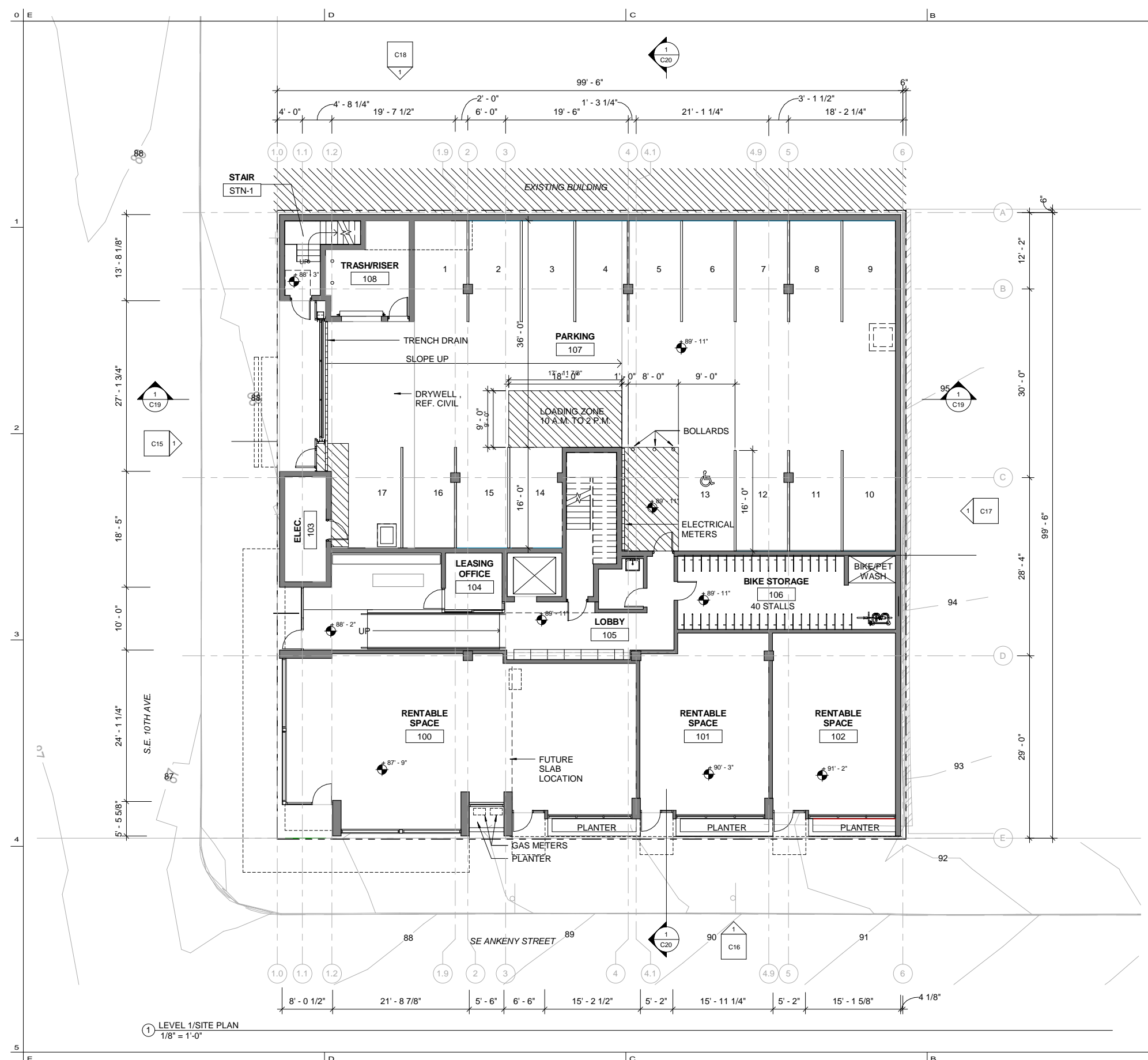

① LEVEL 1/SITE PLAN
1/8" = 1'-0"

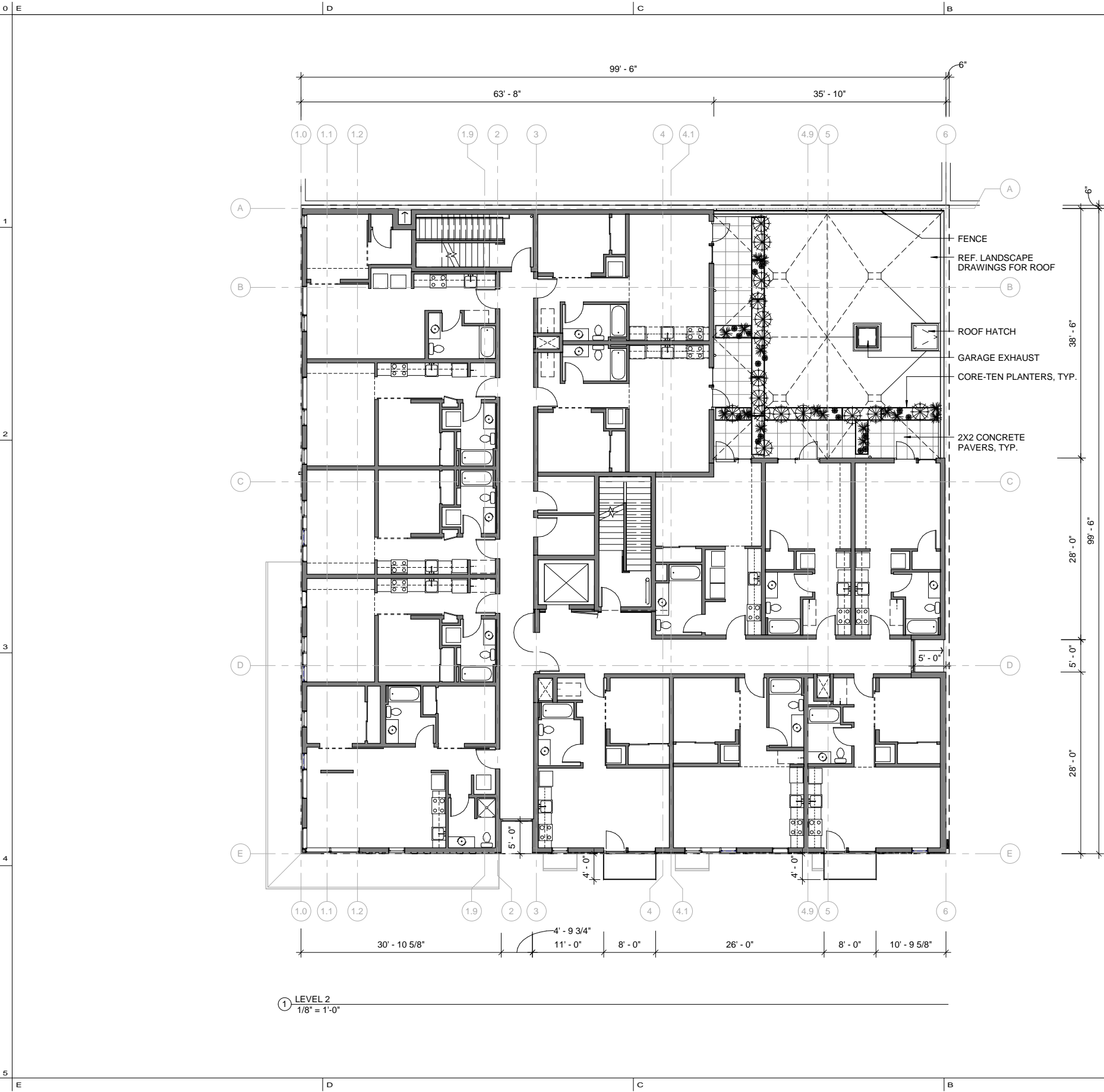

① LEVEL 2
1/8" = 1'-0"

AREA CALCULATED :
 - EXTERIOR FACE OF EXTERIOR WALL
 - CORRIDOR FACE OF CORRIDOR WALL
 - CENTERLINE OF DEMISING WALL

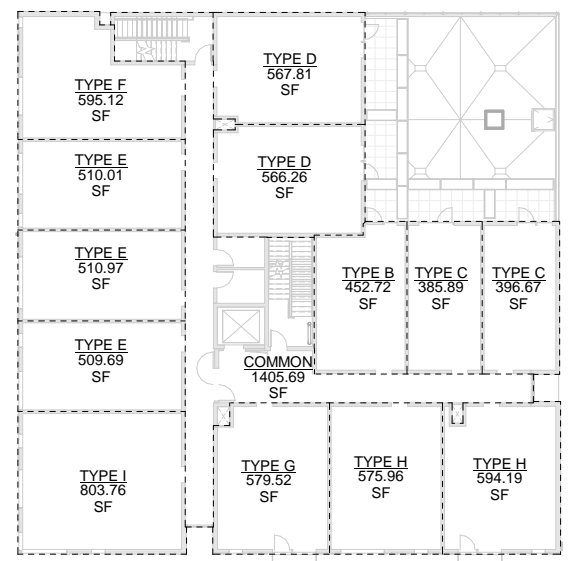

② LEVEL 2 AREA CALCULATIONS
1/16" = 1'-0"

Area Schedule (Rentable) - Level 2		
# BR	TYPE	AREA
	COMMON	1405.69 SF
1	COMMON	1405.69 SF
1 BR		
1 BR	TYPE D	566.26 SF
1 BR	TYPE D	567.81 SF
1 BR	TYPE E	509.69 SF
1 BR	TYPE E	510.97 SF
1 BR	TYPE E	510.01 SF
1 BR	TYPE F	595.12 SF
1 BR	TYPE G	579.52 SF
1 BR	TYPE H	575.96 SF
1 BR	TYPE H	594.19 SF
1 BR: 9		5009.51 SF
2 BR		
2 BR	TYPE I	803.76 SF
2 BR: 1		803.76 SF
STUDIO		
STUDIO	TYPE B	452.72 SF
STUDIO	TYPE C	396.67 SF
STUDIO	TYPE C	385.89 SF
STUDIO: 3		1235.28 SF
Grand total: 14		8454.25 SF



VALLASTER CORL ARCHITECTS, PC
 711 SW ALDER
 PENTHOUSE SUITE
 PORTLAND, OR 97205
 PHONE : 503.228.0311
 FAX : 503.228.0314
 www.vcarch.com

OWNER :
 LOWER BURNSIDE LOFTS, LLC.

PROJECT NAME :
 LOWER BURNSIDE LOFTS
 30 SE 10TH

REVISIONS :

ISSUE DATES :
 FOR PERMIT (01.09.2014)

JOB NO. : 1303
 DRAWN : Author
 CHECKED : Checker
 STATUS : PERMIT

LEVEL 2

C8

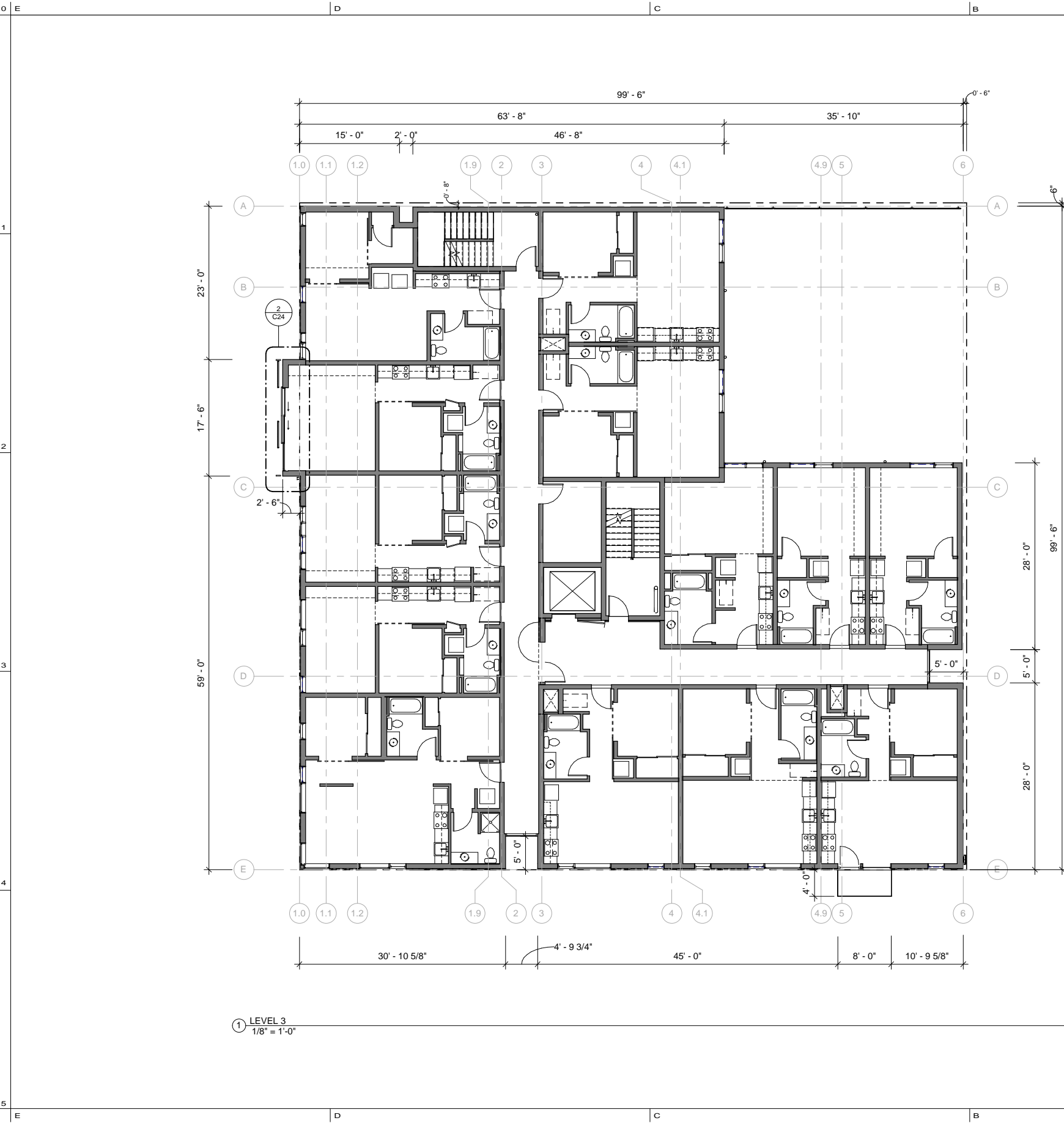

① LEVEL 3
1/8" = 1'-0"

AREA CALCULATED :

- EXTERIOR FACE OF EXTERIOR WALL
- CORRIDOR FACE OF CORRIDOR WALL
- CENTERLINE OF DEMISING WALL

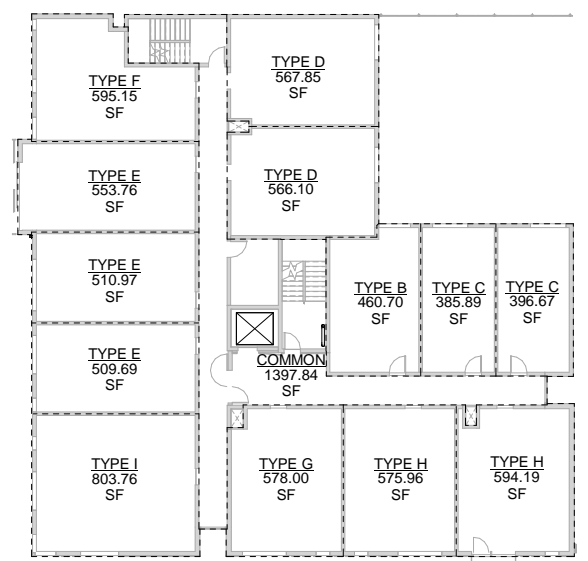

② LEVEL 3 AREA CALCULATIONS
1/16" = 1'-0"

Area Schedule (Rentable) - Level 3		
# BR	TYPE	AREA
	COMMON	1397.84 SF
: 1		1397.84 SF
1 BR		
1 BR	TYPE D	567.85 SF
1 BR	TYPE D	566.10 SF
1 BR	TYPE E	510.97 SF
1 BR	TYPE E	553.76 SF
1 BR	TYPE E	509.69 SF
1 BR	TYPE F	595.15 SF
1 BR	TYPE G	578.00 SF
1 BR	TYPE H	594.19 SF
1 BR	TYPE H	575.96 SF
1 BR: 9		5051.66 SF
2 BR		
2 BR	TYPE I	803.76 SF
2 BR: 1		803.76 SF
STUDIO		
STUDIO	TYPE B	460.70 SF
STUDIO	TYPE C	385.89 SF
STUDIO	TYPE C	396.67 SF
STUDIO: 3		1243.25 SF
Grand total: 14		8496.51 SF



VALLASTER CORL ARCHITECTS, PC
711 SW ALDER
PENTHOUSE SUITE
PORTLAND, OR 97205
PHONE : 503.228.0311
FAX : 503.228.0314
www.vcarch.com

OWNER :
LOWER BURNSIDE LOFTS, LLC.

PROJECT NAME :
LOWER BURNSIDE LOFTS
30 SE 10TH

REVISIONS :

ISSUE DATES :
FOR PERMIT (01.09.2014)

JOB NO. : 1303
DRAWN : Author
CHECKED : Checker
STATUS : PERMIT

LEVEL 3

C9



VALLASTER CORL ARCHITECTS, PC
 711 SW ALDER
 PENTHOUSE SUITE
 PORTLAND, OR 97205
 PHONE : 503.228.0311
 FAX : 503.228.0314
 www.vcarch.com

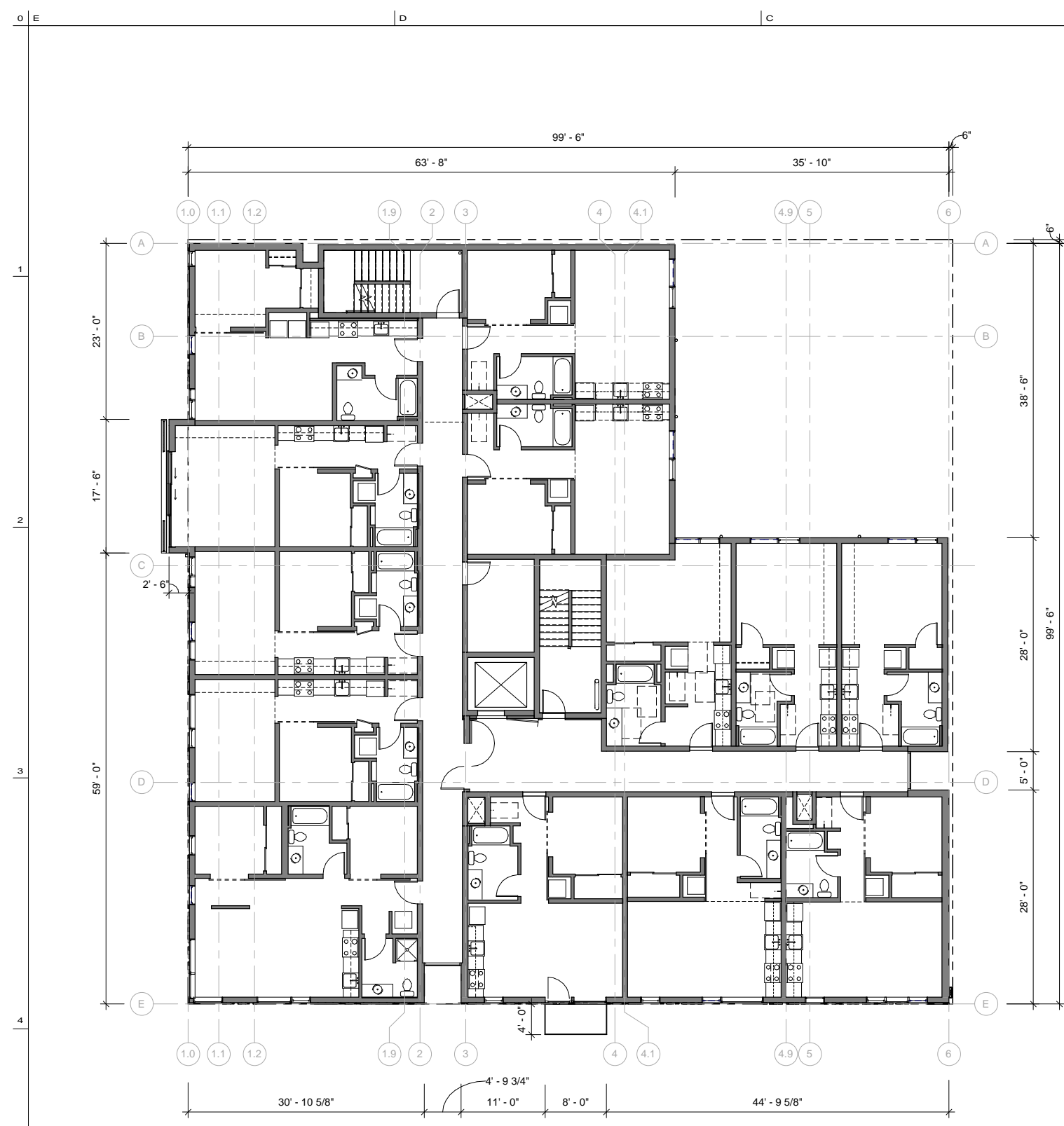

1 LEVEL 4
 1/8" = 1'-0"

AREA CALCULATED :
 - EXTERIOR FACE OF EXTERIOR WALL
 - CORRIDOR FACE OF CORRIDOR WALL
 - CENTERLINE OF DEMISING WALL

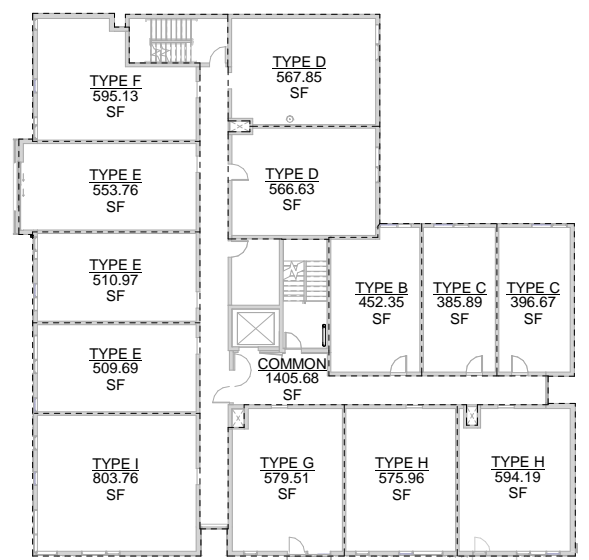

2 LEVEL 4 AREA CALCULATIONS
 1/16" = 1'-0"

Area Schedule (Rentable) - Level 4		
# BR	TYPE	AREA
	COMMON	1405.68 SF
: 1		
1405.68 SF		
1 BR		
1 BR	TYPE D	567.85 SF
1 BR	TYPE D	566.63 SF
1 BR	TYPE E	510.97 SF
1 BR	TYPE E	553.76 SF
1 BR	TYPE E	509.69 SF
1 BR	TYPE F	595.13 SF
1 BR	TYPE G	579.51 SF
1 BR	TYPE H	594.19 SF
1 BR	TYPE H	575.96 SF
1 BR: 9		5053.68 SF
2 BR		
2 BR	TYPE I	803.76 SF
2 BR: 1		803.76 SF
STUDIO		
STUDIO	TYPE B	452.35 SF
STUDIO	TYPE C	385.89 SF
STUDIO	TYPE C	396.67 SF
STUDIO: 3		1234.91 SF
Grand total: 14		8498.03 SF

OWNER:
 LOWER BURNSIDE LOFTS, LLC.

PROJECT NAME:
LOWER BURNSIDE LOFTS
 30 SE 10TH

REVISIONS:

ISSUE DATES:
 FOR PERMIT (01.09.2014)

JOB NO.: 1303
 DRAWN: Author
 CHECKED: Checker
 STATUS: PERMIT

LEVEL 4

C10



VALLASTER CORL ARCHITECTS, PC
 711 SW ALDER
 PENTHOUSE SUITE
 PORTLAND, OR 97205
 PHONE : 503.228.0311
 FAX : 503.228.0314
 www.vcarch.com

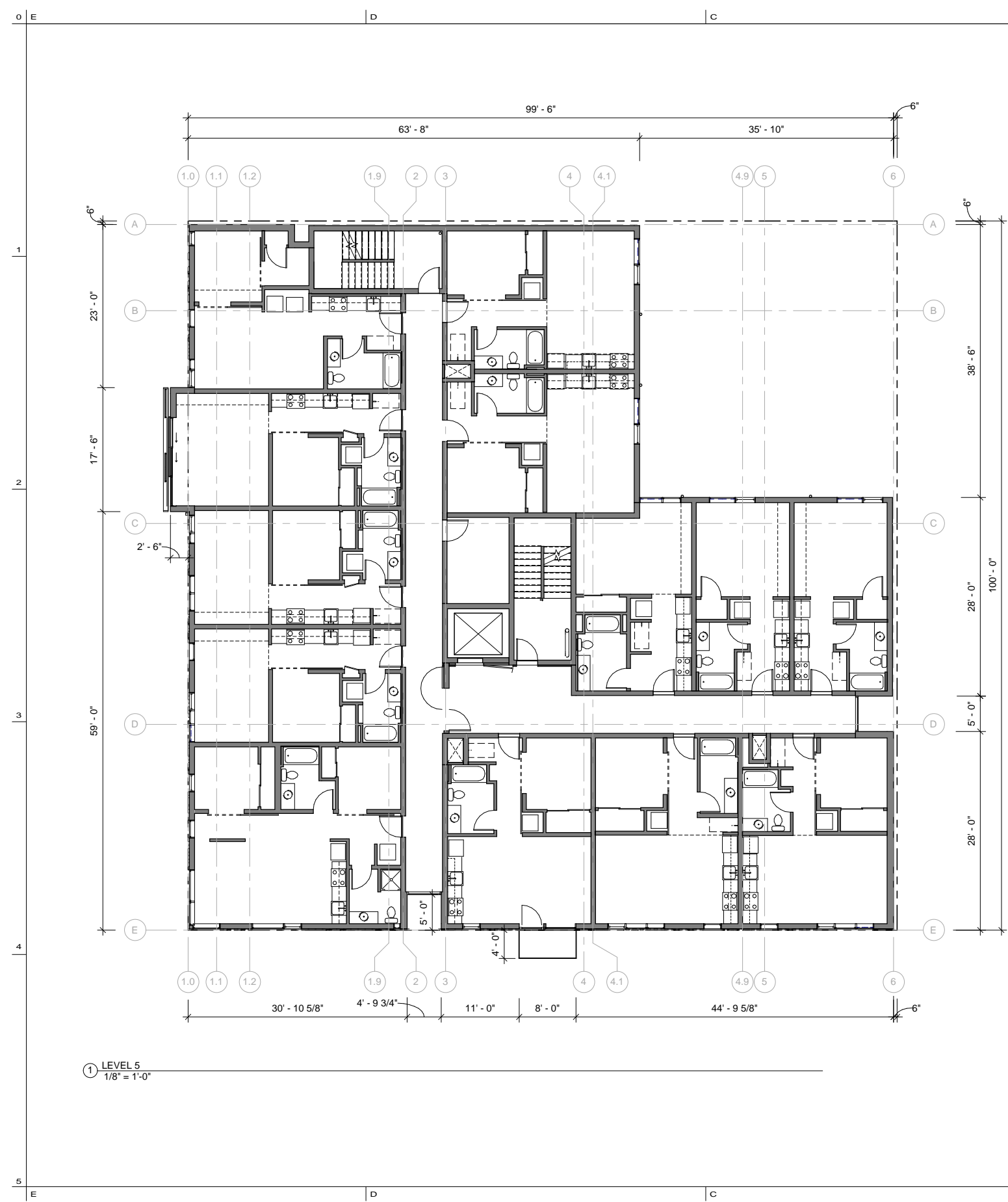

① LEVEL 5
 1/8" = 1'-0"

AREA CALCULATED :
 - EXTERIOR FACE OF EXTERIOR WALL
 - CORRIDOR FACE OF CORRIDOR WALL
 - CENTERLINE OF DEMISING WALL

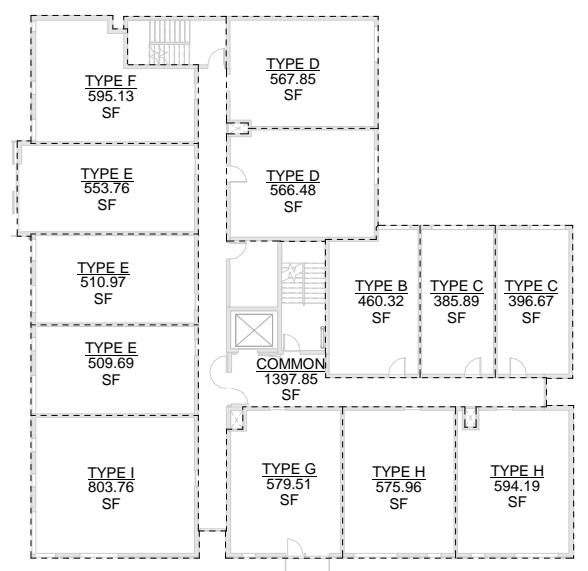

② LEVEL 5 AREA CALCULATIONS
 1/16" = 1'-0"

Area Schedule (Rentable) - Level 5		
# BR	TYPE	AREA
COMMON		1397.85 SF
: 1		1397.85 SF
1 BR		
1 BR	TYPE D	566.48 SF
1 BR	TYPE D	567.85 SF
1 BR	TYPE E	553.76 SF
1 BR	TYPE E	509.69 SF
1 BR	TYPE E	510.97 SF
1 BR	TYPE F	595.13 SF
1 BR	TYPE G	579.51 SF
1 BR	TYPE H	575.96 SF
1 BR	TYPE H	594.19 SF
1 BR: 9		5053.53 SF
2 BR		
2 BR	TYPE I	803.76 SF
2 BR: 1		803.76 SF
STUDIO		
STUDIO	TYPE B	460.32 SF
STUDIO	TYPE C	396.67 SF
STUDIO	TYPE C	385.89 SF
STUDIO: 3		1242.89 SF
Grand total: 14		8498.03 SF

OWNER :
 LOWER BURNSIDE LOFTS, LLC.

PROJECT NAME :
LOWER BURNSIDE LOFTS
 30 SE 10TH

REVISIONS :

ISSUE DATES :
 FOR PERMIT (01.09.2014)

JOB NO. : 1303
 DRAWN : Author
 CHECKED : Checker
 STATUS : PERMIT

LEVEL 5
C11



VALLASTER CORL ARCHITECTS, PC
 711 SW ALDER
 PENTHOUSE SUITE
 PORTLAND, OR 97205
 PHONE : 503.228.0311
 FAX : 503.228.0314
 www.vcarch.com

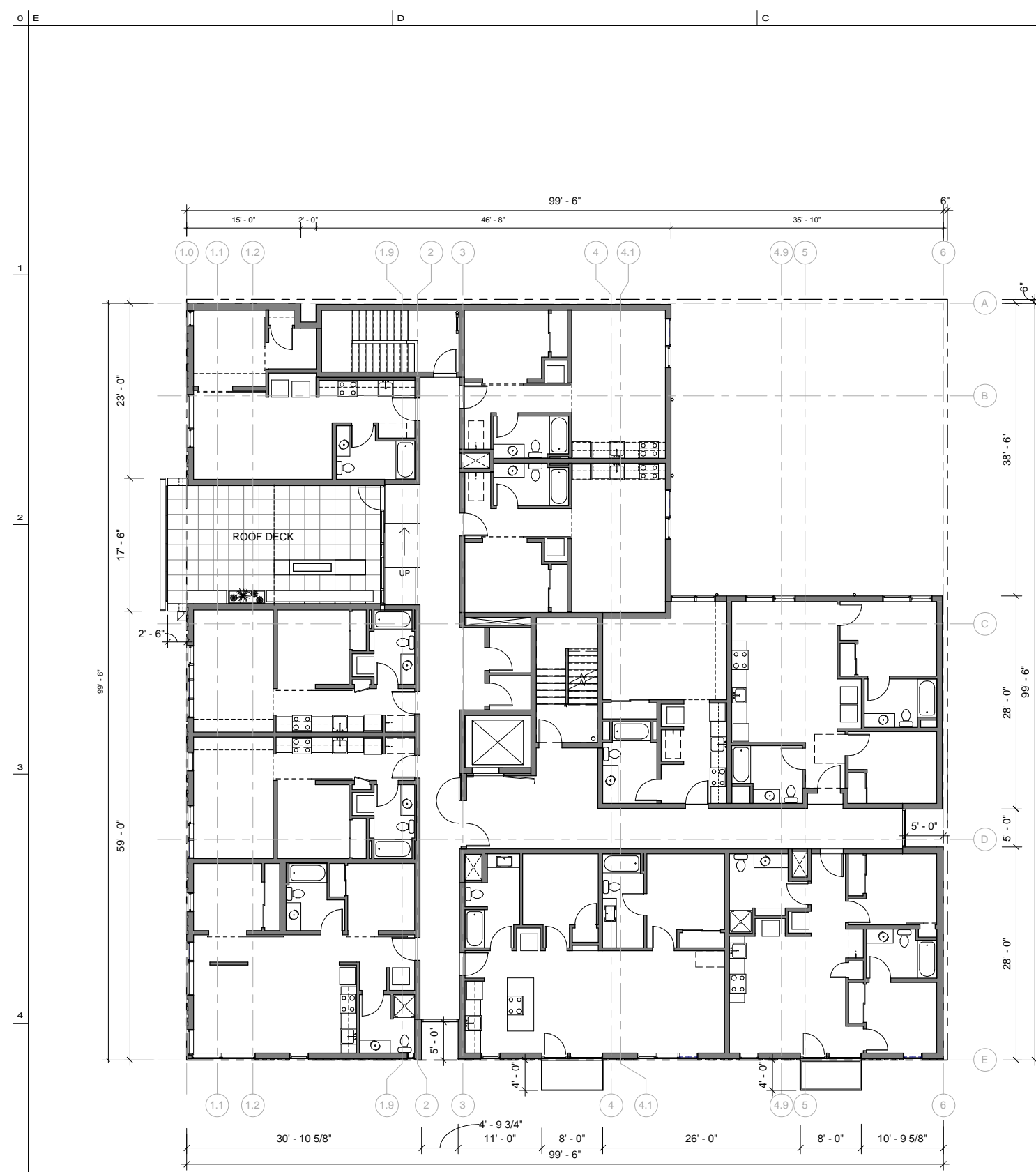

1 LEVEL 6
 1/8" = 1'-0"

AREA CALCULATED :
 - EXTERIOR FACE OF EXTERIOR WALL
 - CORRIDOR FACE OF CORRIDOR WALL
 - CENTERLINE OF DEMISING WALL

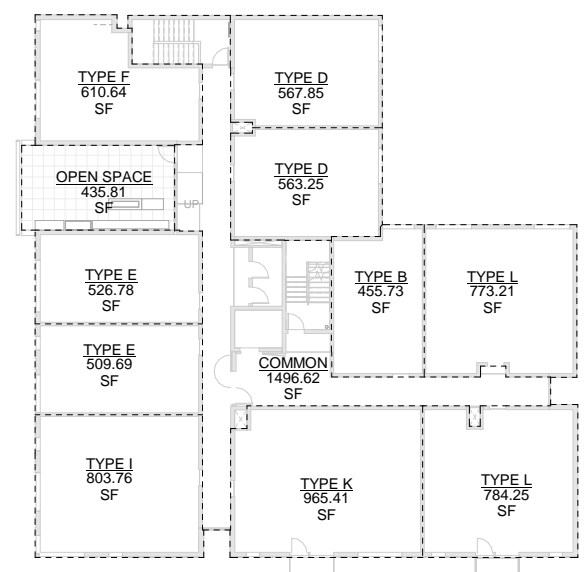

2 LEVEL 6 AREA CALCULATIONS
 1/16" = 1'-0"

Area Schedule (Rentable) - Level 6		
Type	Name	Area
	COMMON	1496.62 SF
: 1		1496.62 SF
1 BR		
1 BR	TYPE D	563.25 SF
1 BR	TYPE D	567.85 SF
1 BR	TYPE E	526.78 SF
1 BR	TYPE E	509.69 SF
1 BR	TYPE F	610.64 SF
1 BR: 5		2778.20 SF
2 BR		
2 BR	TYPE I	803.76 SF
2 BR	TYPE K	965.41 SF
2 BR	TYPE L	773.21 SF
2 BR	TYPE L	784.25 SF
2 BR: 4		3326.63 SF
STUDIO		
STUDIO	TYPE B	455.73 SF
STUDIO: 1		455.73 SF
Grand total: 11		8057.17 SF

OWNER:
 LOWER BURNSIDE LOFTS, LLC.

PROJECT NAME:
LOWER BURNSIDE LOFTS
 30 SE 10TH

REVISIONS:

ISSUE DATES:
 FOR PERMIT (01.09.2014)

JOB NO.: 1303
 DRAWN: Author
 CHECKED: Checker
 STATUS: PERMIT

LEVEL 6
C12

o E

D

C

B

A

o

1

2

3

4

5

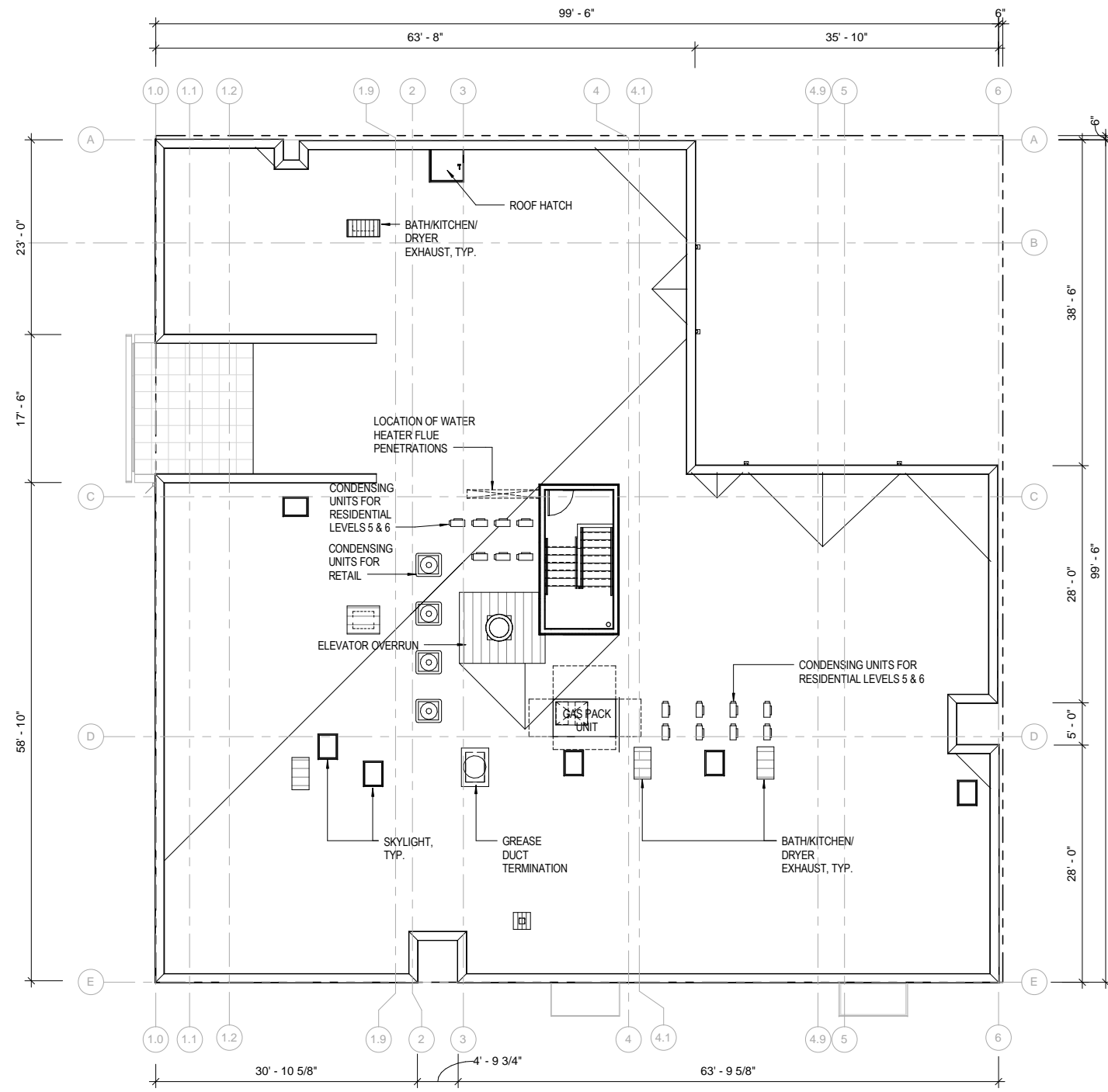

1 ROOF PLAN
1/8" = 1'-0"



VALLASTER CORL ARCHITECTS, PC
711 SW ALDER
PENTHOUSE SUITE
PORTLAND, OR 97205
PHONE : 503.228.0311
FAX : 503.228.0314
www.vcarch.com

OWNER :
LOWER BURNSIDE LOFTS, LLC.

PROJECT NAME :
LOWER BURNSIDE LOFTS
30 SE 10TH

REVISIONS :

ISSUE DATES :
FOR PERMIT (01.09.2014)

JOB NO. : 1303
DRAWN : Author
CHECKED : Checker
STATUS : PERMIT

ROOF

C13

5 ORIGINAL SHEET SIZE : 22"x34"

o E

D

C

B

A

o

1

2



3

4

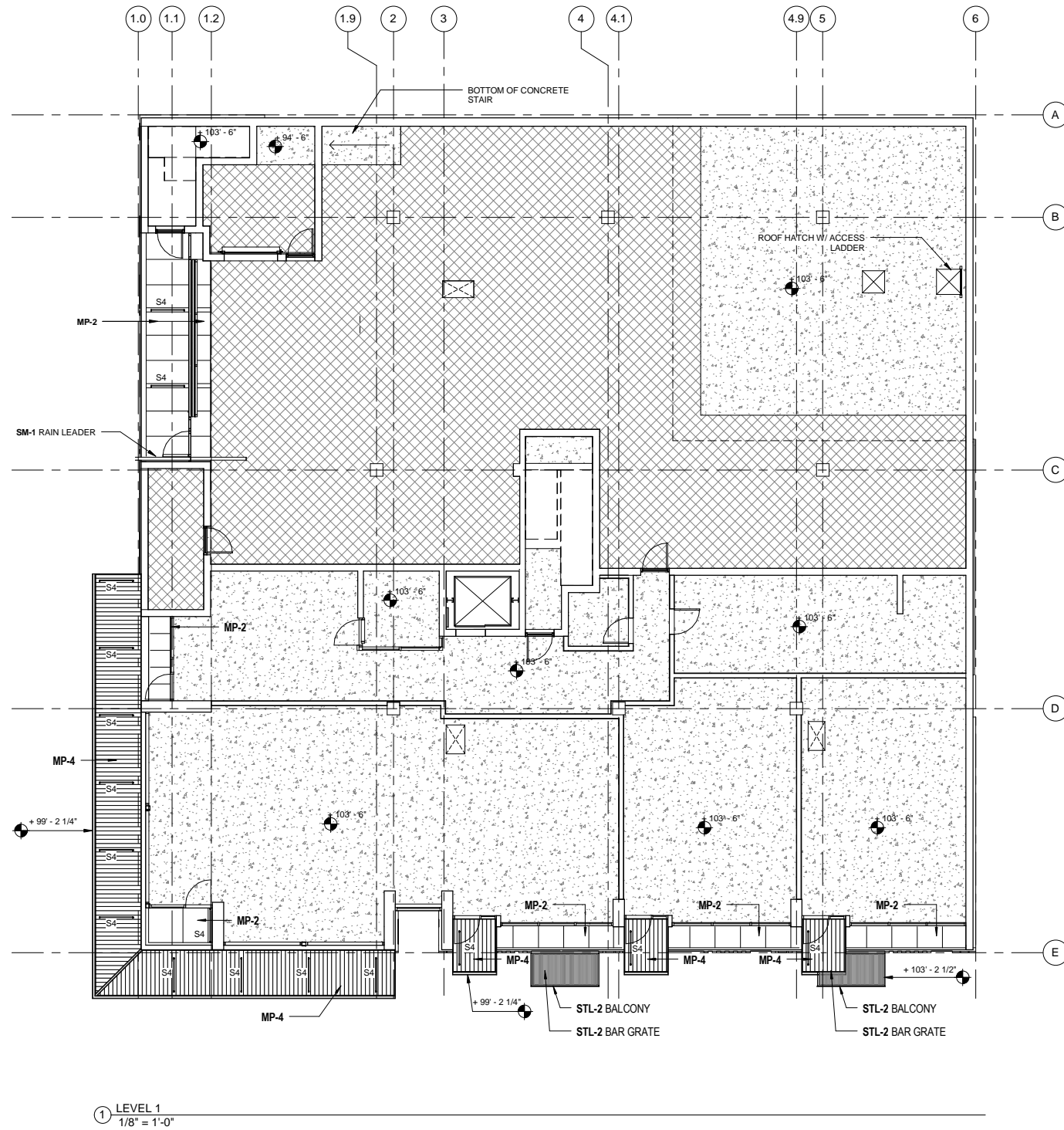
5



LEGEND

- CONCRETE STRUCTURE
-  EXPOSED CONCRETE
 -  INSULATION
 -  GYP. BD. CEILING

① LEVEL 1
1/8" = 1'-0"



VALLASTER CORL ARCHITECTS, PC
711 SW ALDER
PENTHOUSE SUITE
PORTLAND, OR 97205
PHONE : 503.228.0311
FAX : 503.228.0314
www.vcarch.com

OWNER :
LOWER BURNSIDE LOFTS, LLC.

PROJECT NAME :
LOWER BURNSIDE LOFTS
30 SE 10TH

REVISIONS :

ISSUE DATES :
FOR PERMIT (01.09.2014)

JOB NO. : 1303
DRAWN : Author
CHECKED : Checker
STATUS : PERMIT

LEVEL 1 RCP

C14

5 ORIGINAL SHEET SIZE : 22"x34"



VALLASTER CORL ARCHITECTS, PC
 711 SW ALDER
 PENTHOUSE SUITE
 PORTLAND, OR 97205
 PHONE : 503.228.0311
 FAX : 503.228.0314
 www.vcarch.com

OWNER:
 LOWER BURNSIDE LOFTS, LLC.

PROJECT NAME:
 LOWER BURNSIDE LOFTS
 30 SE 10TH

REVISIONS:

ISSUE DATES:

FOR PERMIT (01.09.2014)

JOB NO.:	1303
DRAWN:	JM
CHECKED:	DV
STATUS:	PERMIT

ELEVATION - WEST
C15

ORIGINAL SHEET SIZE : 22"x34"



1 EXTERIOR ELEVATION - WEST
 SCALE: 3/16" = 1'-0"



① ELEVATION- SOUTH
3/16" = 1'-0"



VALLASTER CORL ARCHITECTS, PC
711 SW ALDER
PENTHOUSE SUITE
PORTLAND, OR 97205
PHONE : 503.228.0311
FAX : 503.228.0314
www.vcarch.com

OWNER:
LOWER BURNSIDE LOFTS, LLC.

PROJECT NAME:
LOWER BURNSIDE LOFTS
30 SE 10TH

REVISIONS:

ISSUE DATES:
FOR PERMIT (01.09.2014)

JOB NO.: 1303
DRAWN: Author
CHECKED: Checker
STATUS: PERMIT

ELEVATION - SOUTH
C16



VALLASTER CORL ARCHITECTS, PC
 711 SW ALDER
 PENTHOUSE SUITE
 PORTLAND, OR 97205
 PHONE : 503.228.0311
 FAX : 503.228.0314
 www.vcarch.com

OWNER :
 LOWER BURNSIDE LOFTS, LLC.

PROJECT NAME :
LOWER BURNSIDE LOFTS
 30 SE 10TH

REVISIONS :

ISSUE DATES :
 FOR PERMIT (01.09.2014)

JOB NO. : 1303
 DRAWN : Author
 CHECKED : Checker
 STATUS : PERMIT

ELEVATION - EAST
C17

ORIGINAL SHEET SIZE : 22"x34"



VALLASTER CORL ARCHITECTS, PC
 711 SW ALDER
 PENTHOUSE SUITE
 PORTLAND, OR 97205
 PHONE : 503.228.0311
 FAX : 503.228.0314
 www.vcarch.com

OWNER :
 LOWER BURNSIDE LOFTS, LLC.

PROJECT NAME :
LOWER BURNSIDE LOFTS
 30 SE 10TH

REVISIONS :

ISSUE DATES :

FOR PERMIT (01.09.2014)

JOB NO. : 1303
 DRAWN : Author
 CHECKED : Checker
 STATUS : PERMIT

ELEVATION - NORTH
C18

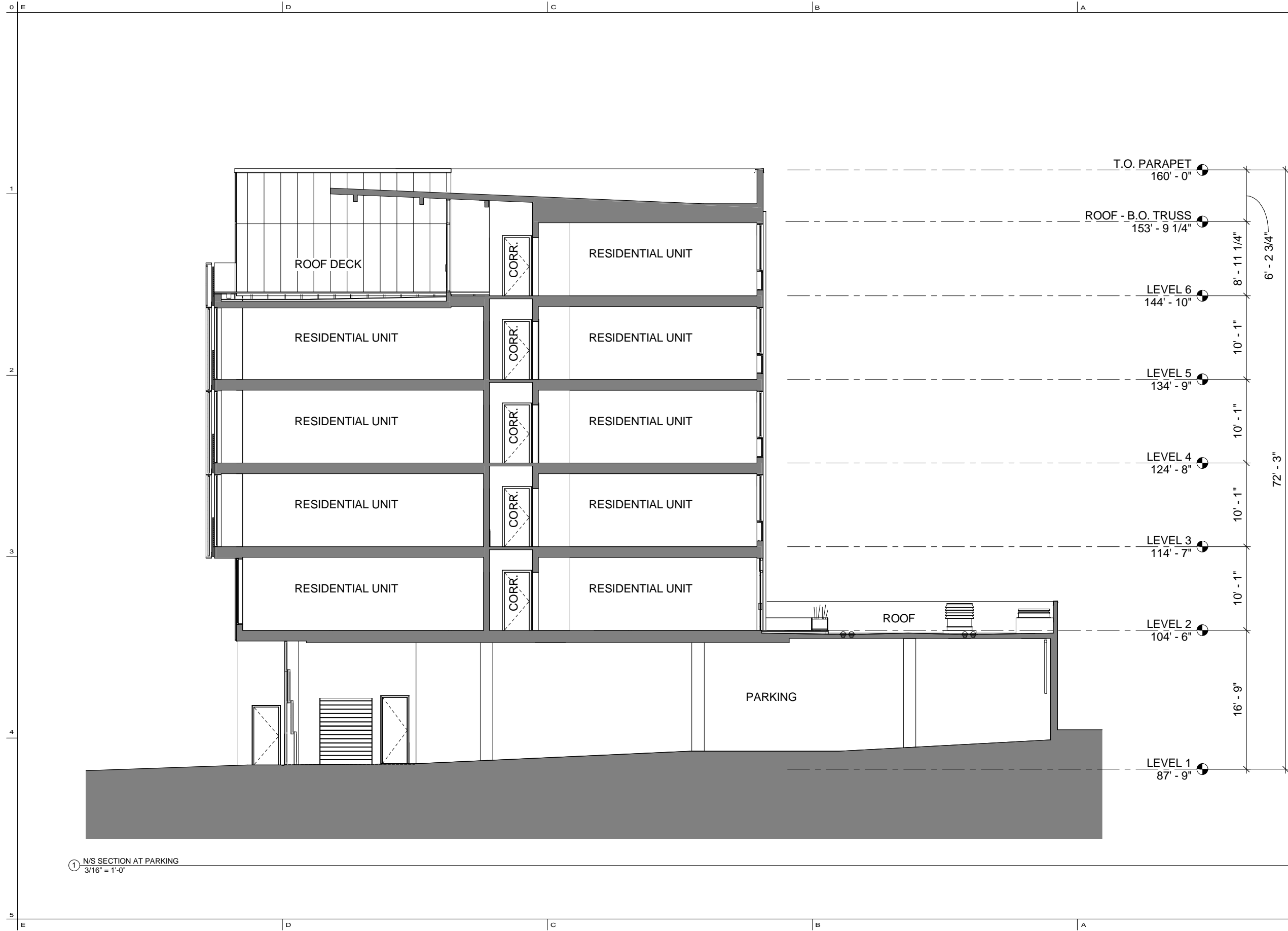

VALLASTER CORL ARCHITECTS, PC
 711 SW ALDER
 PENTHOUSE SUITE
 PORTLAND, OR 97205
 PHONE : 503.228.0311
 FAX : 503.228.0314
 www.vcarch.com

OWNER :
 LOWER BURNSIDE LOFTS, LLC.

PROJECT NAME :
LOWER BURNSIDE LOFTS
 30 SE 10TH

REVISIONS :

ISSUE DATES :
 FOR PERMIT (01.09.2014)

JOB NO. : 1303
 DRAWN : Author
 CHECKED : Checker
 STATUS : PERMIT

BUILDING SECTION
C19

ORIGINAL SHEET SIZE : 22"x34"

① N/S SECTION AT PARKING
 3/16" = 1'-0"

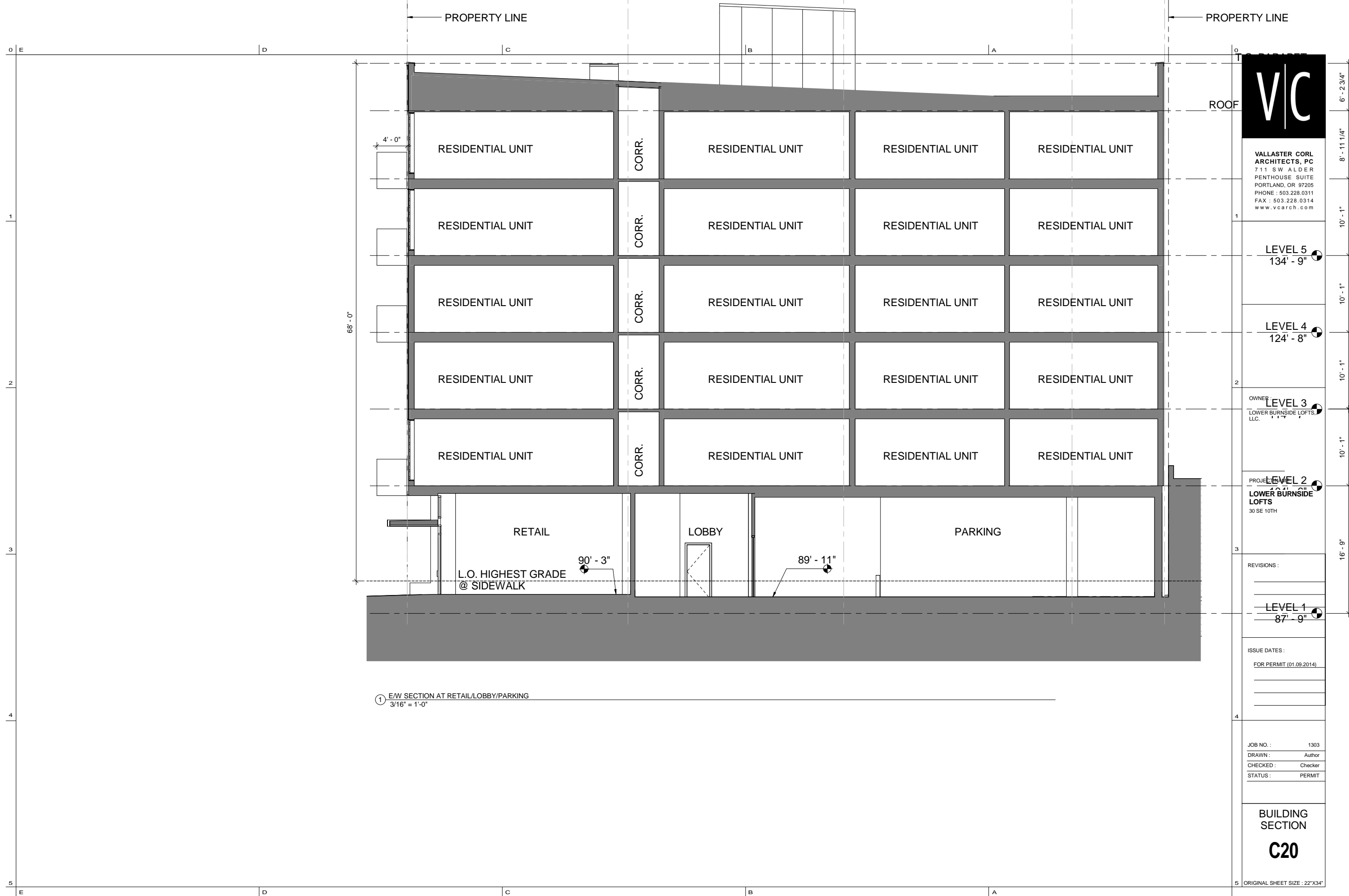

VALLASTER CORL ARCHITECTS, PC
 711 SW ALDER
 PENTHOUSE SUITE
 PORTLAND, OR 97205
 PHONE : 503.228.0311
 FAX : 503.228.0314
 www.vcarch.com

LEVEL 5
 134' - 9"

LEVEL 4
 124' - 8"

OWNER :
 LEVEL 3
 LOWER BURNSIDE LOFTS, LLC.

PROJECT :
 LEVEL 2
 LOWER BURNSIDE LOFTS
 30 SE 10TH

REVISIONS :

LEVEL 1
 87' - 9"

ISSUE DATES :
 FOR PERMIT (01.09.2014)

JOB NO. : 1303
 DRAWN : Author
 CHECKED : Checker
 STATUS : PERMIT

BUILDING SECTION
C20

ORIGINAL SHEET SIZE : 22"x34"

① E-W SECTION AT RETAIL/LOBBY/PARKING
 3/16" = 1'-0"

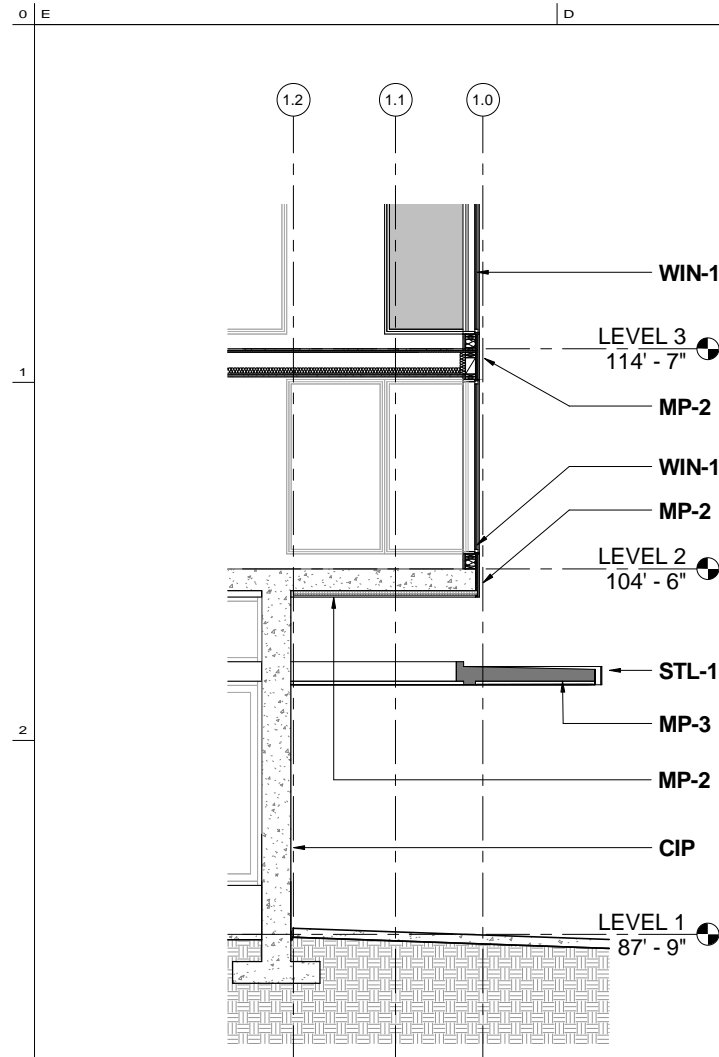

1 SECTION @ CORNER RETAIL ENTRY
1/4" = 1'-0"

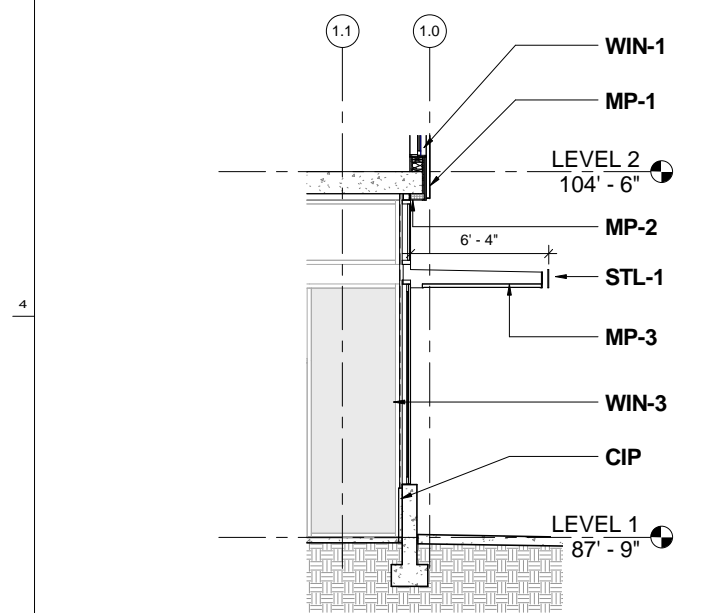

2 SECTION THRU RETAIL CANOPY
1/4" = 1'-0"

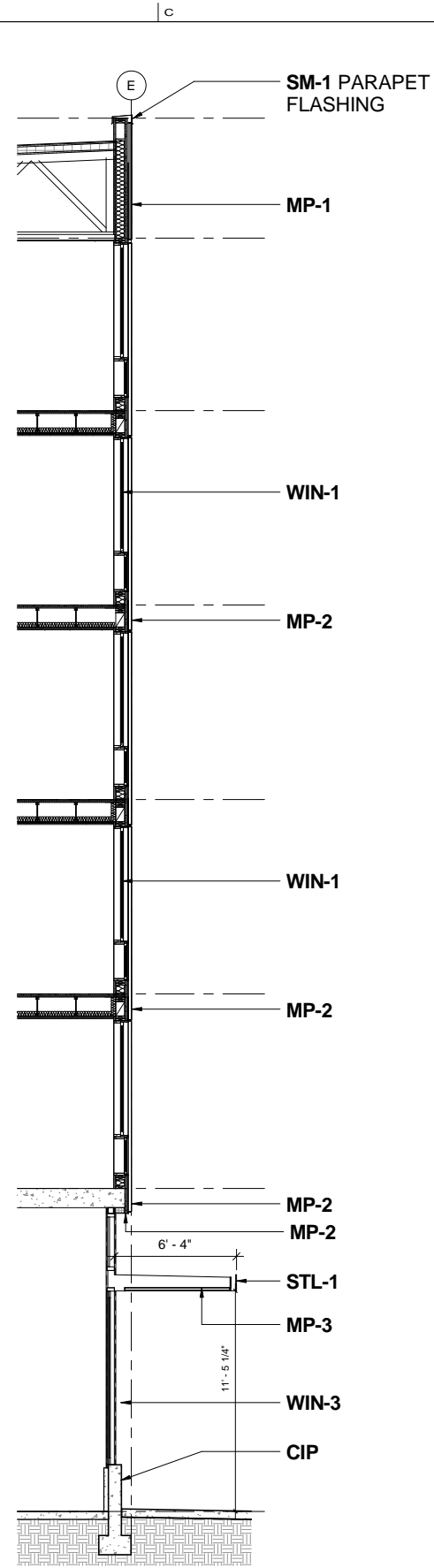

5 SECTION @ 1.3
1/4" = 1'-0"

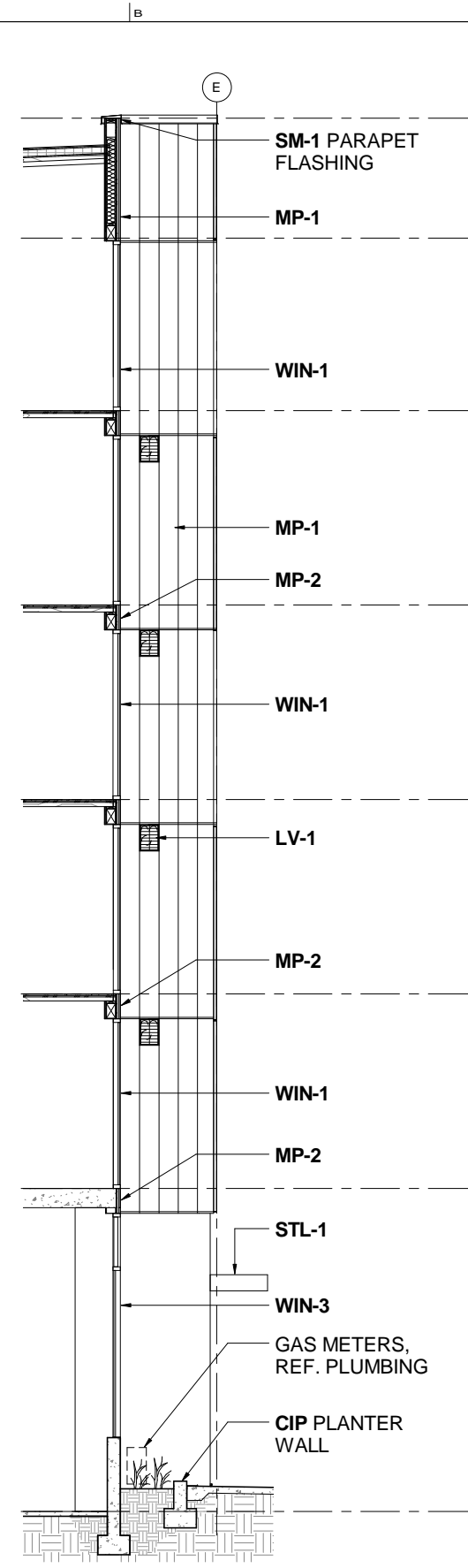

4 SECTION -WEST-THRU G.L. 2.5
1/4" = 1'-0"

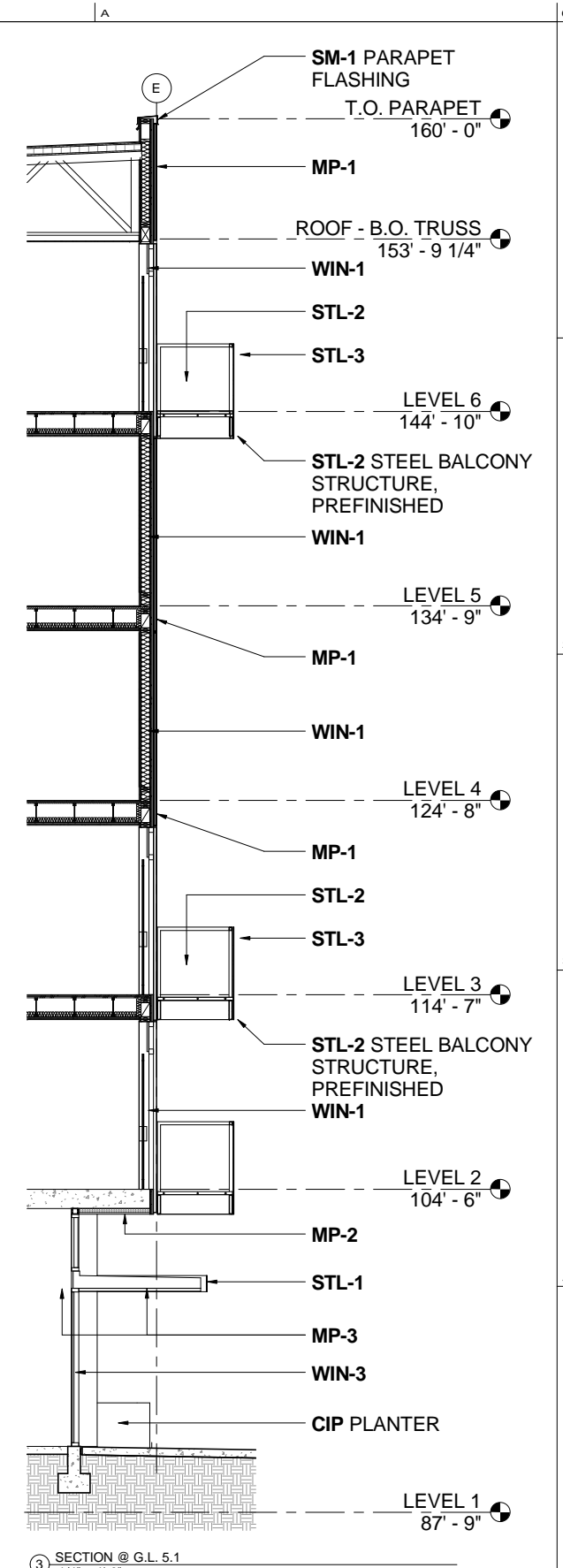

3 SECTION @ G.L. 5.1
1/4" = 1'-0"



VALLASTER CORL ARCHITECTS, PC
711 SW ALDER
PENTHOUSE SUITE
PORTLAND, OR 97205
PHONE : 503.228.0311
FAX : 503.228.0314
www.vcarch.com

OWNER :
LOWER BURNSIDE LOFTS, LLC.

PROJECT NAME :
LOWER BURNSIDE LOFTS
30 SE 10TH

REVISIONS :

ISSUE DATES :
FOR PERMIT (01.09.2014)

JOB NO. : 1303
DRAWN : Author
CHECKED : Checker
STATUS : PERMIT

WALL SECTIONS

C21

ORIGINAL SHEET SIZE : 22"x34"

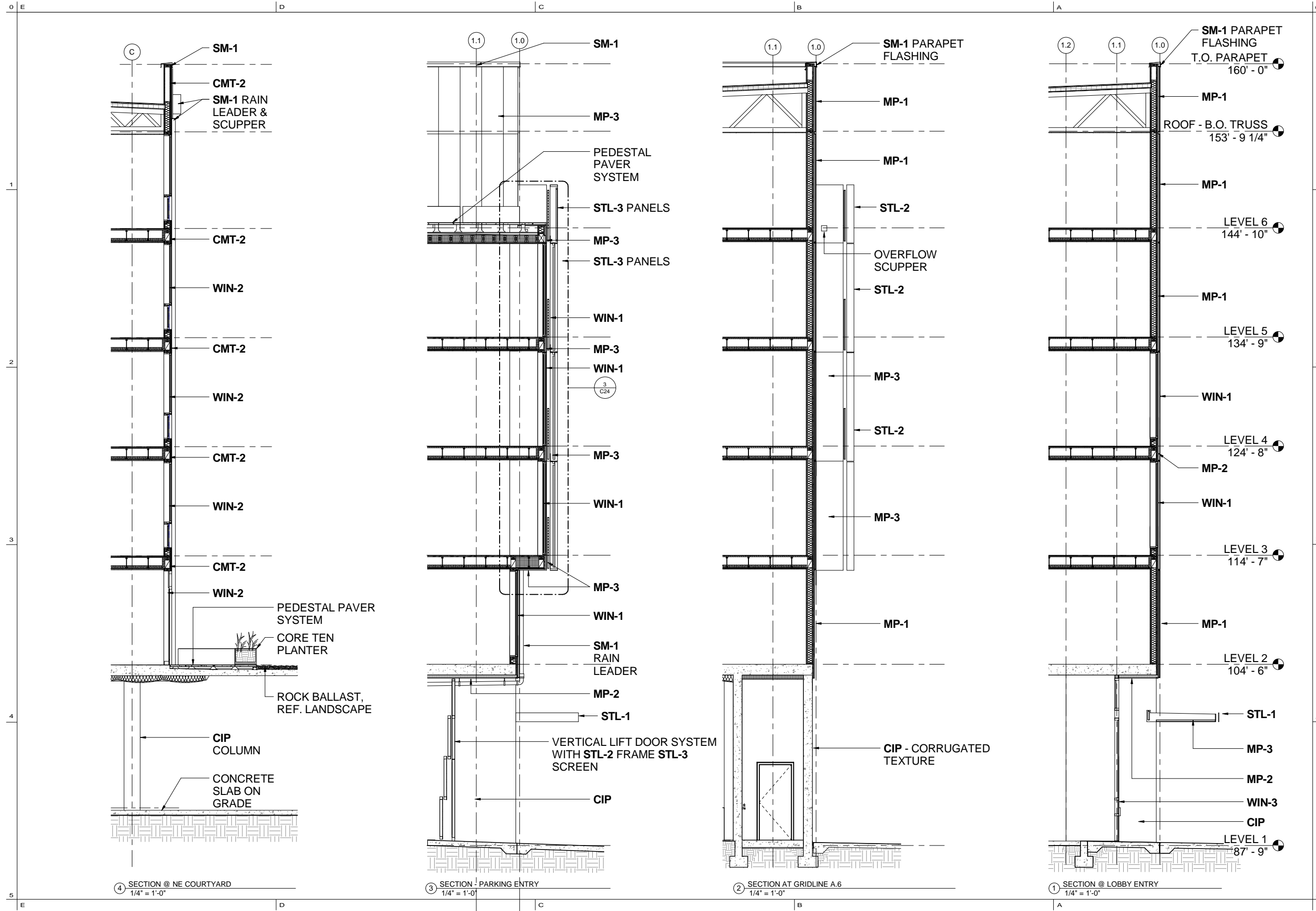

VALLASTER CORL ARCHITECTS, PC
 711 SW ALDER
 PENTHOUSE SUITE
 PORTLAND, OR 97205
 PHONE : 503.228.0311
 FAX : 503.228.0314
 www.vcarch.com

OWNER :
 LOWER BURNSIDE LOFTS, LLC.

PROJECT NAME :
 LOWER BURNSIDE LOFTS
 30 SE 10TH

REVISIONS :

ISSUE DATES :
 FOR PERMIT (01.09.2014)

JOB NO. : 1303
 DRAWN : Author
 CHECKED : Checker
 STATUS : PERMIT

WALL SECTIONS

C22

5 ORIGINAL SHEET SIZE : 22"x34"

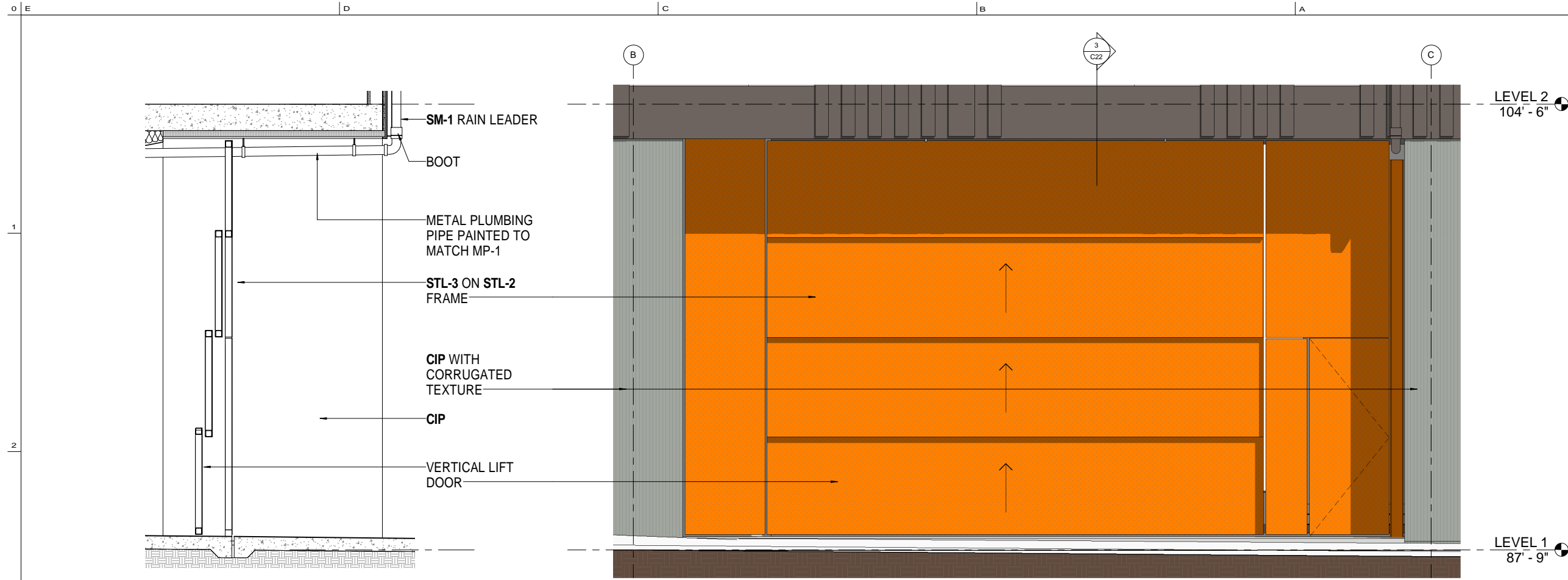

② SECTION AT PARKING GATE
1/2" = 1'-0"

① ENLARGED ELEVATION - GARAGE
1/2" = 1'-0"

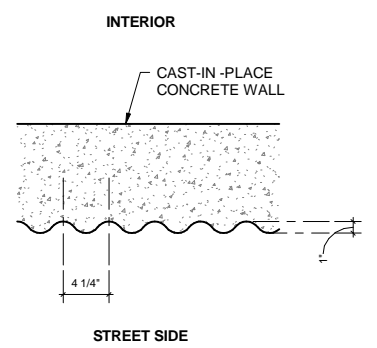

④ Copy of CORRUGATED CONCRETE
1 1/2" = 1'-0"

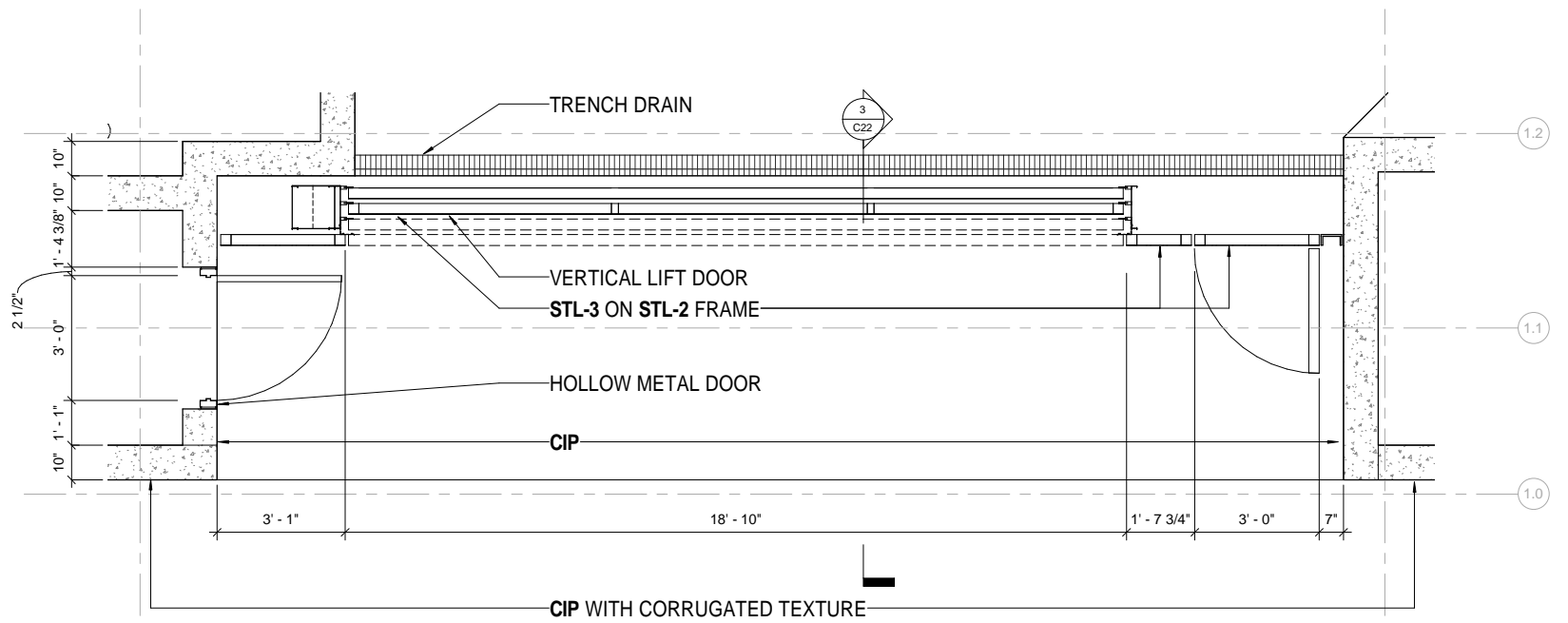

VALLASTER CORL ARCHITECTS, PC
711 SW ALDER
PENTHOUSE SUITE
PORTLAND, OR 97205
PHONE : 503.228.0311
FAX : 503.228.0314
www.vcarch.com

OWNER:
LOWER BURNSIDE LOFTS, LLC.

PROJECT NAME:
LOWER BURNSIDE LOFTS
30 SE 10TH

REVISIONS:

ISSUE DATES:
FOR PERMIT (01.09.2014)

JOB NO.: 1303
DRAWN: Author
CHECKED: Checker
STATUS: PERMIT

ENLARGED ELEVATIONS
C23

ORIGINAL SHEET SIZE : 22"x34"

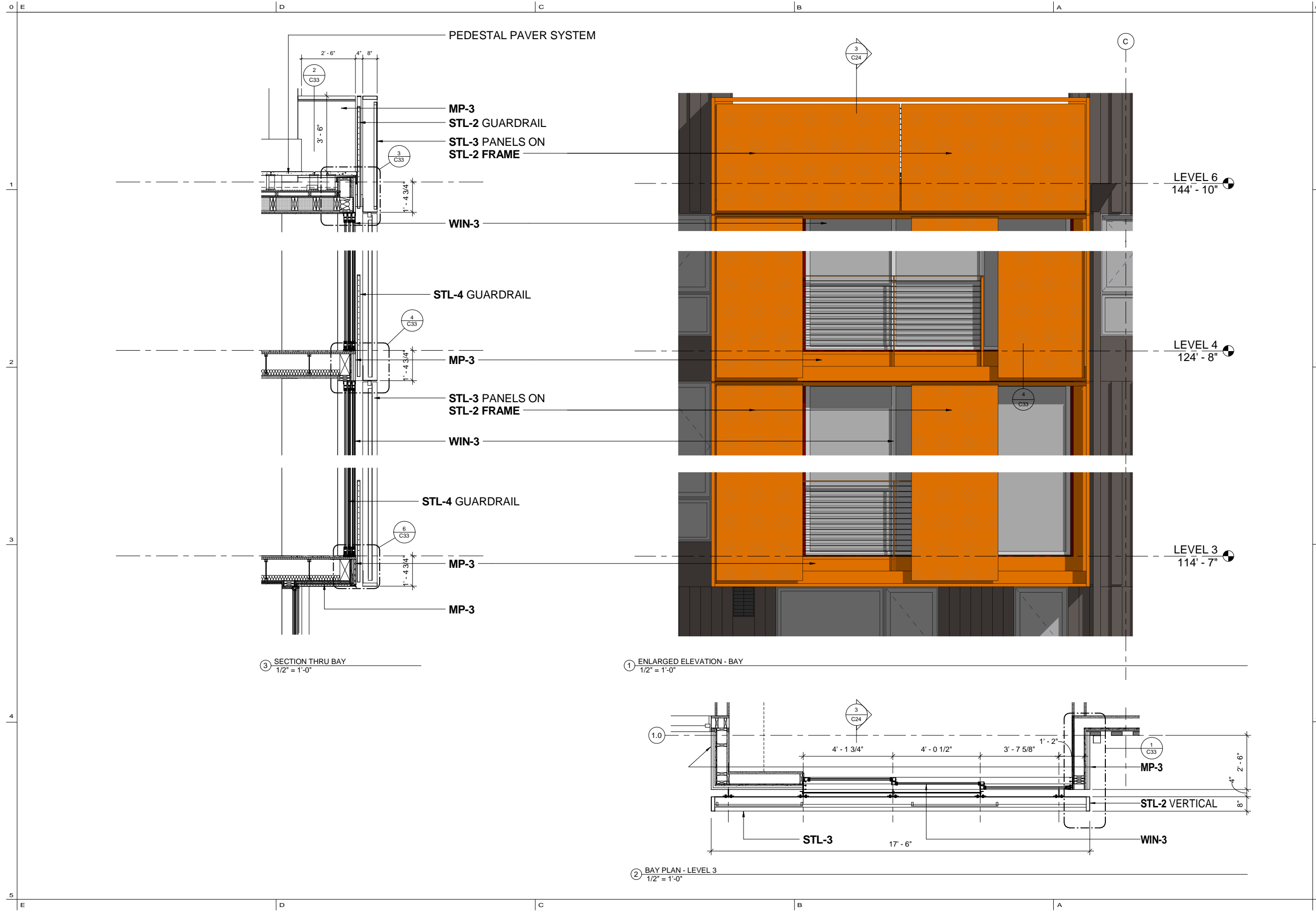

VALLASTER CORL ARCHITECTS, PC
 711 SW ALDER
 PENTHOUSE SUITE
 PORTLAND, OR 97205
 PHONE : 503.228.0311
 FAX : 503.228.0314
 www.vcarch.com

OWNER:
 LOWER BURNSIDE LOFTS, LLC.

PROJECT NAME:
LOWER BURNSIDE LOFTS
 30 SE 10TH

REVISIONS:

ISSUE DATES:
 FOR PERMIT (01.09.2014)

JOB NO.: 1303
 DRAWN: Author
 CHECKED: Checker
 STATUS: PERMIT

ENLARGED ELEVATIONS

C24

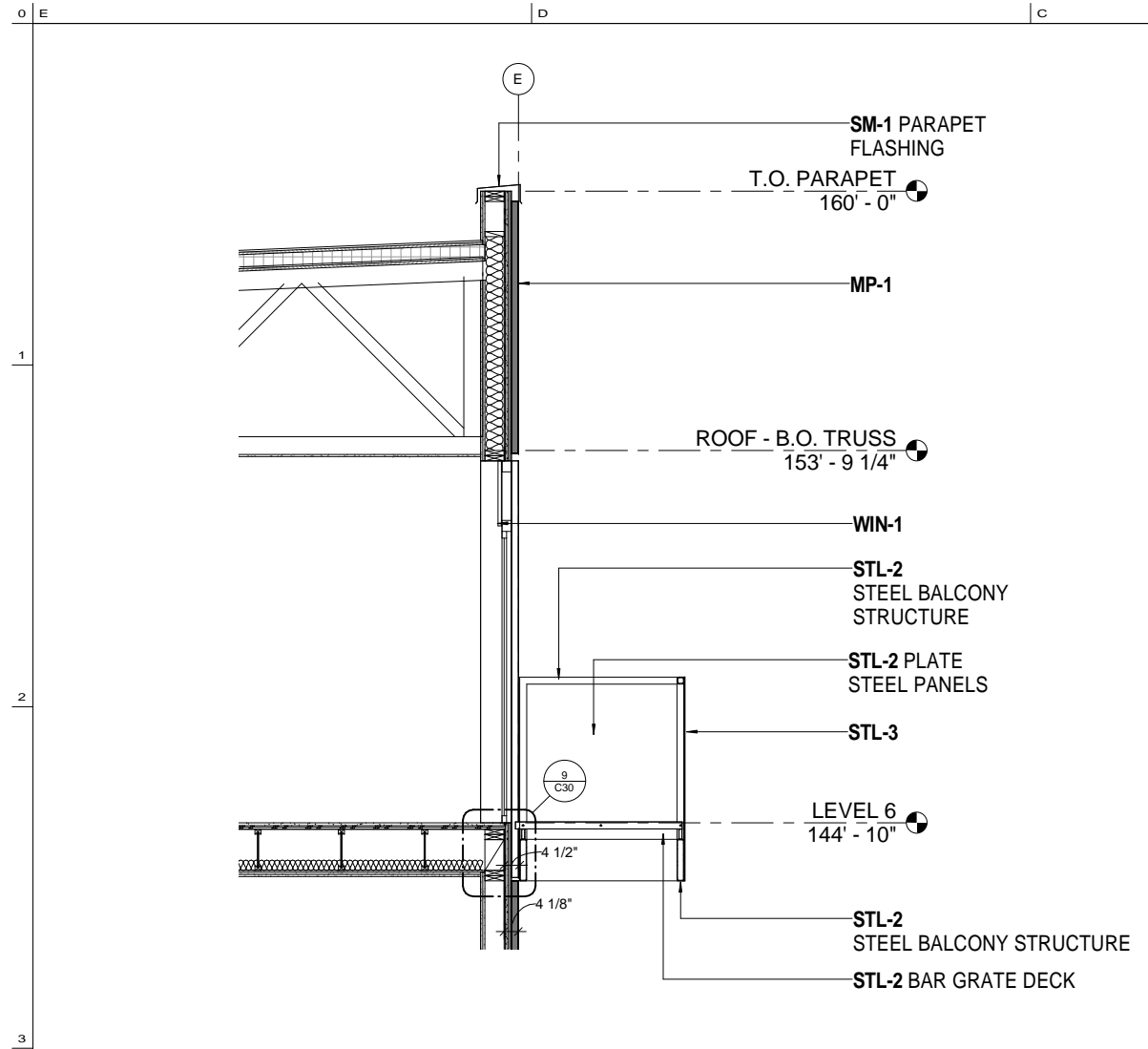

2 SECTION AT BALCONY
1/2" = 1'-0"

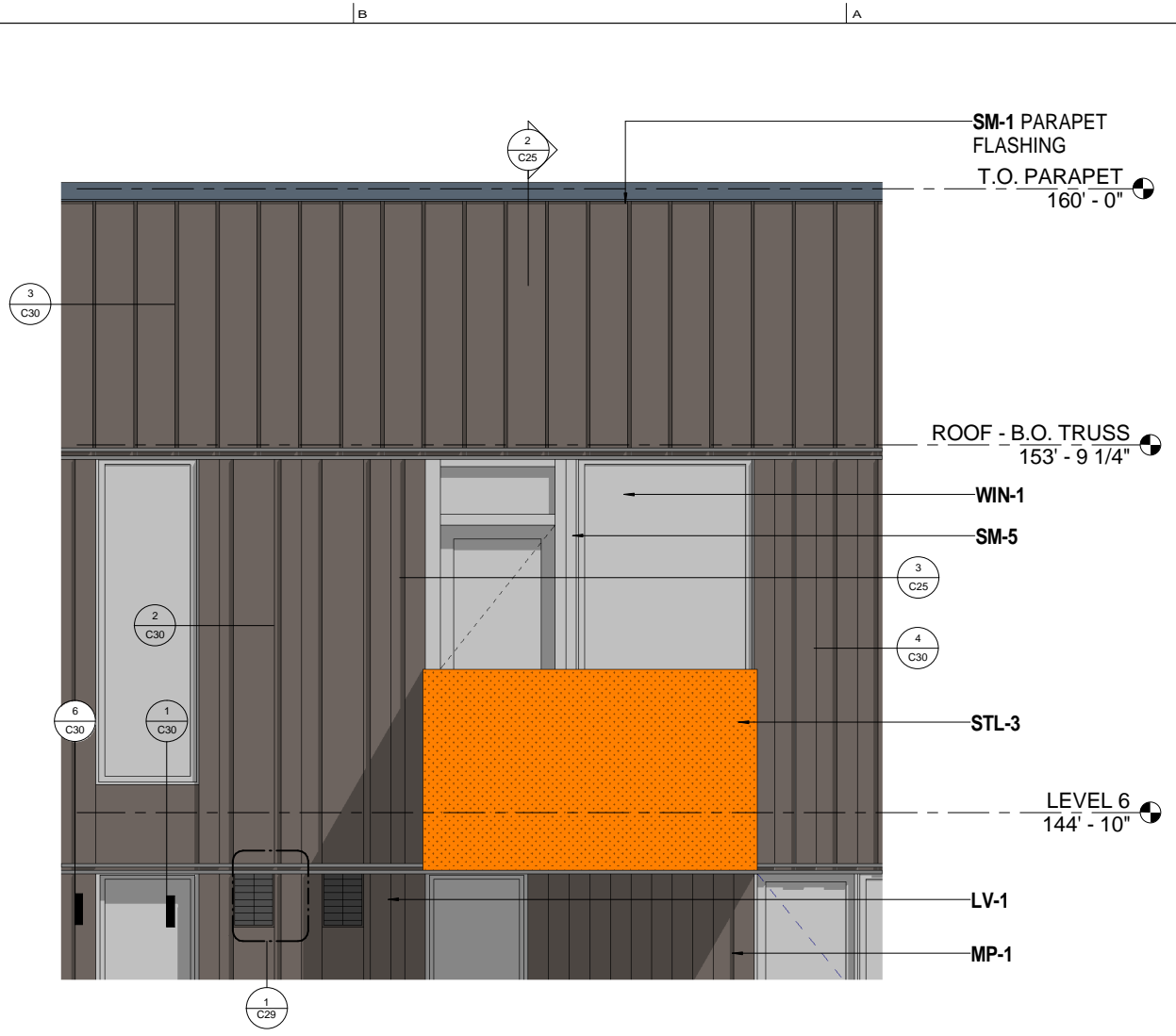

1 ENLARGED ELEVATION - BALCONY/WINDOW
1/2" = 1'-0"

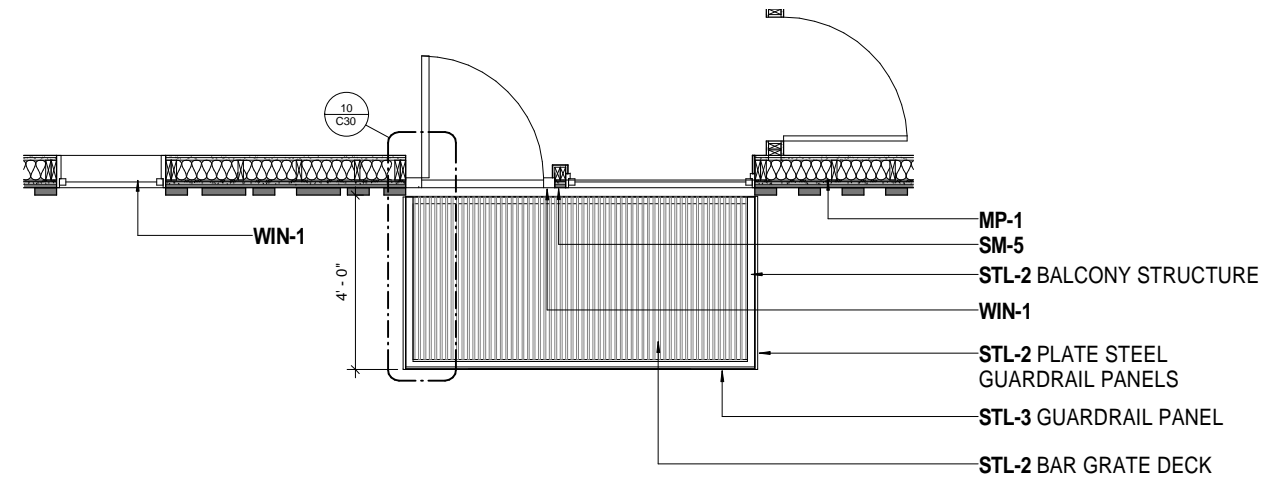

3 PLAN - BALCONY
1/2" = 1'-0"



VALLASTER CORL ARCHITECTS, PC
711 SW ALDER
PENTHOUSE SUITE
PORTLAND, OR 97205
PHONE : 503.228.0311
FAX : 503.228.0314
www.vcarch.com

OWNER :
LOWER BURNSIDE LOFTS, LLC.

PROJECT NAME :
LOWER BURNSIDE LOFTS
30 SE 10TH

REVISIONS :

ISSUE DATES :
FOR PERMIT (01.09.2014)

JOB NO. : 1303
DRAWN : Author
CHECKED : Checker
STATUS : PERMIT

ENLARGED ELEVATIONS

C25

ORIGINAL SHEET SIZE : 22"x34"

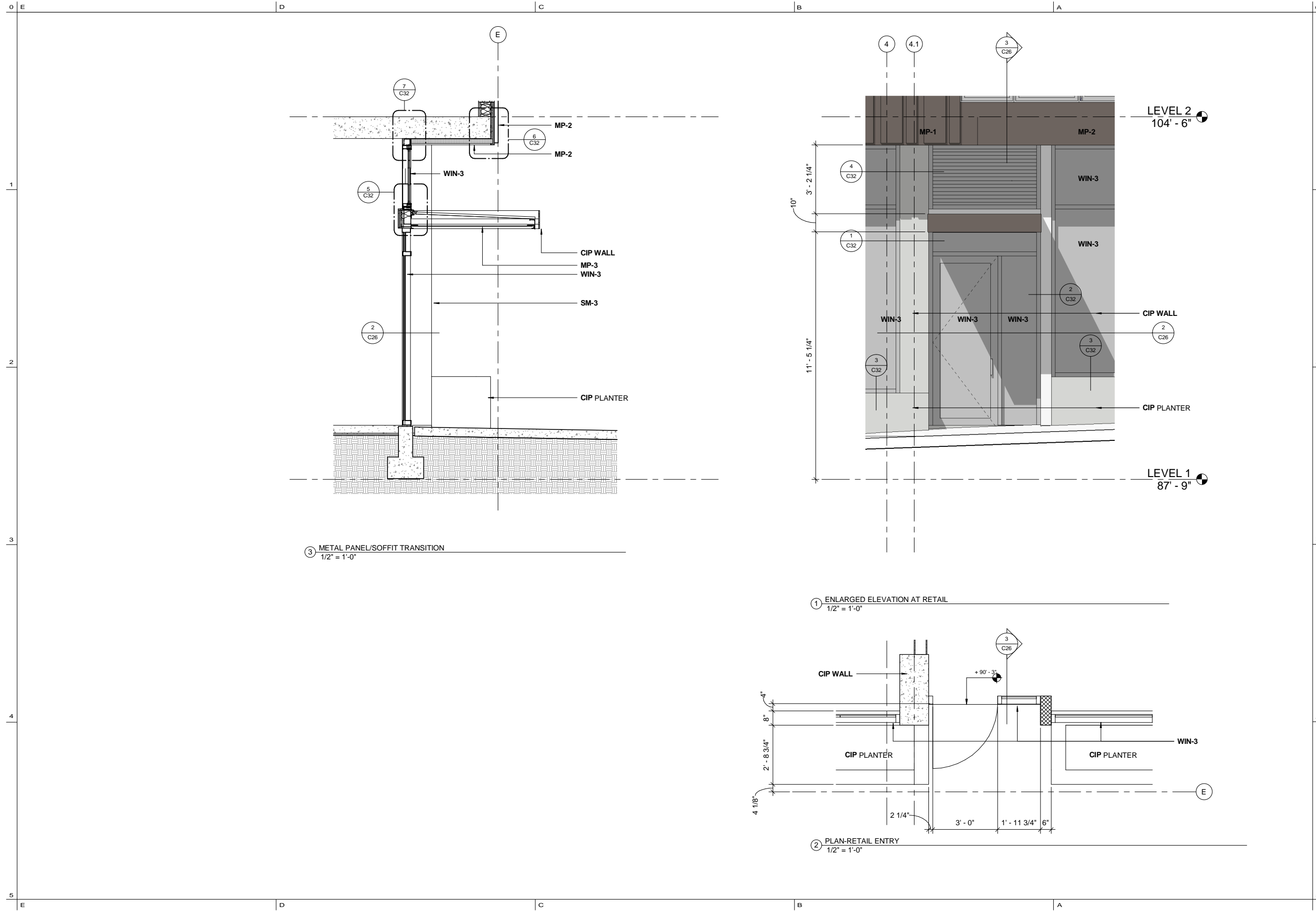

③ METAL PANEL/SOFFIT TRANSITION
1/2" = 1'-0"

① ENLARGED ELEVATION AT RETAIL
1/2" = 1'-0"

② PLAN-RETAIL ENTRY
1/2" = 1'-0"



VALLASTER CORL ARCHITECTS, PC
 711 SW ALDER
 PENTHOUSE SUITE
 PORTLAND, OR 97205
 PHONE : 503.228.0311
 FAX : 503.228.0314
 www.vcarch.com

OWNER :
 LOWER BURNSIDE LOFTS, LLC.

PROJECT NAME :
LOWER BURNSIDE LOFTS
 30 SE 10TH

REVISIONS :

ISSUE DATES :
 FOR PERMIT (01.09.2014)

JOB NO. : 1303
 DRAWN : Author
 CHECKED : Checker
 STATUS : PERMIT

ENLARGED ELEVATIONS
C26

ORIGINAL SHEET SIZE : 22"x34"

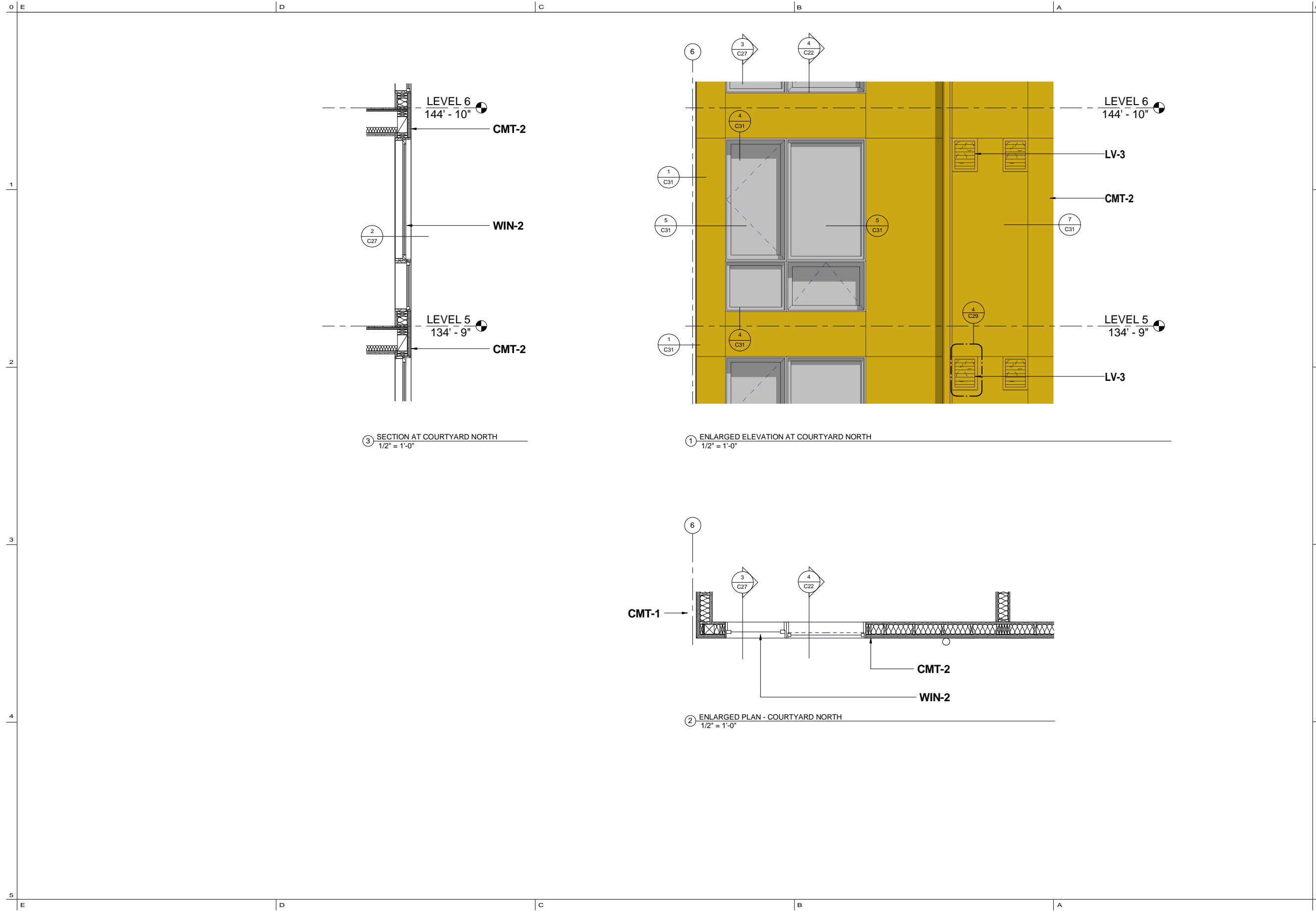

③ SECTION AT COURTYARD NORTH
1/2" = 1'-0"

① ENLARGED ELEVATION AT COURTYARD NORTH
1/2" = 1'-0"

② ENLARGED PLAN - COURTYARD NORTH
1/2" = 1'-0"



VALLASTER CORL ARCHITECTS, PC
711 SW ALDER
PENTHOUSE SUITE
PORTLAND, OR 97205
PHONE : 503.228.0311
FAX : 503.228.0314
www.vcarch.com

OWNER :
LOWER BURNSIDE LOFTS, LLC.

PROJECT NAME :
LOWER BURNSIDE LOFTS
30 SE 10TH

REVISIONS :

ISSUE DATES :

FOR PERMIT (01.09.2014)

JOB NO. :	1303
DRAWN :	Author
CHECKED :	Checker
STATUS :	PERMIT

ENLARGED ELEVATIONS
C27

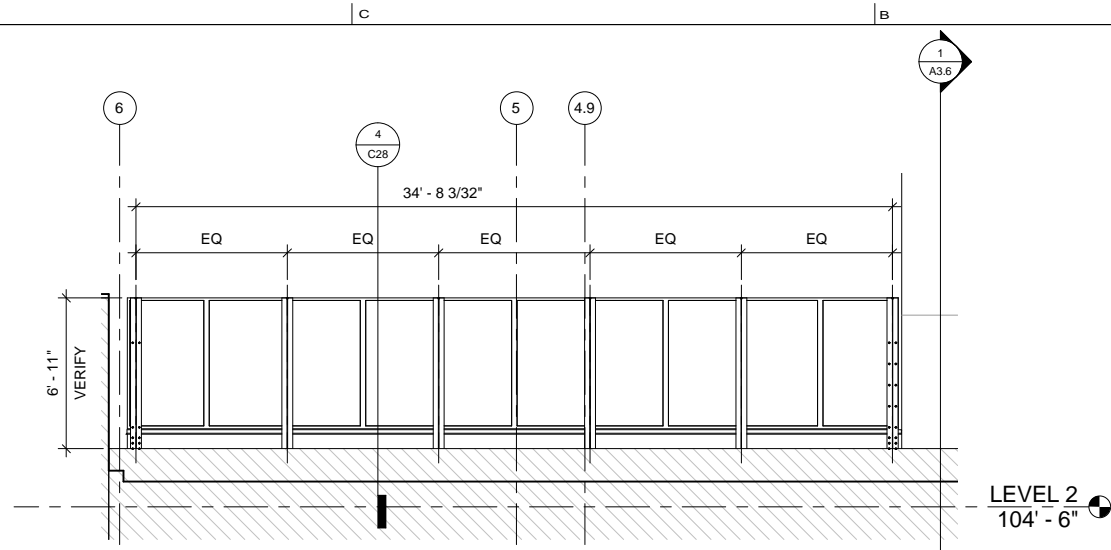

3 NE COURTYARD FENCE ELEVATION
1/4" = 1'-0"

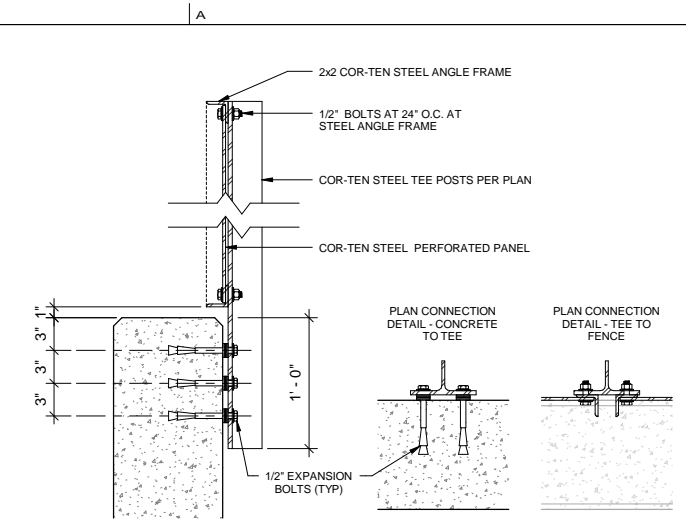

2 FENCE - SECTION
1 1/2" = 1'-0"

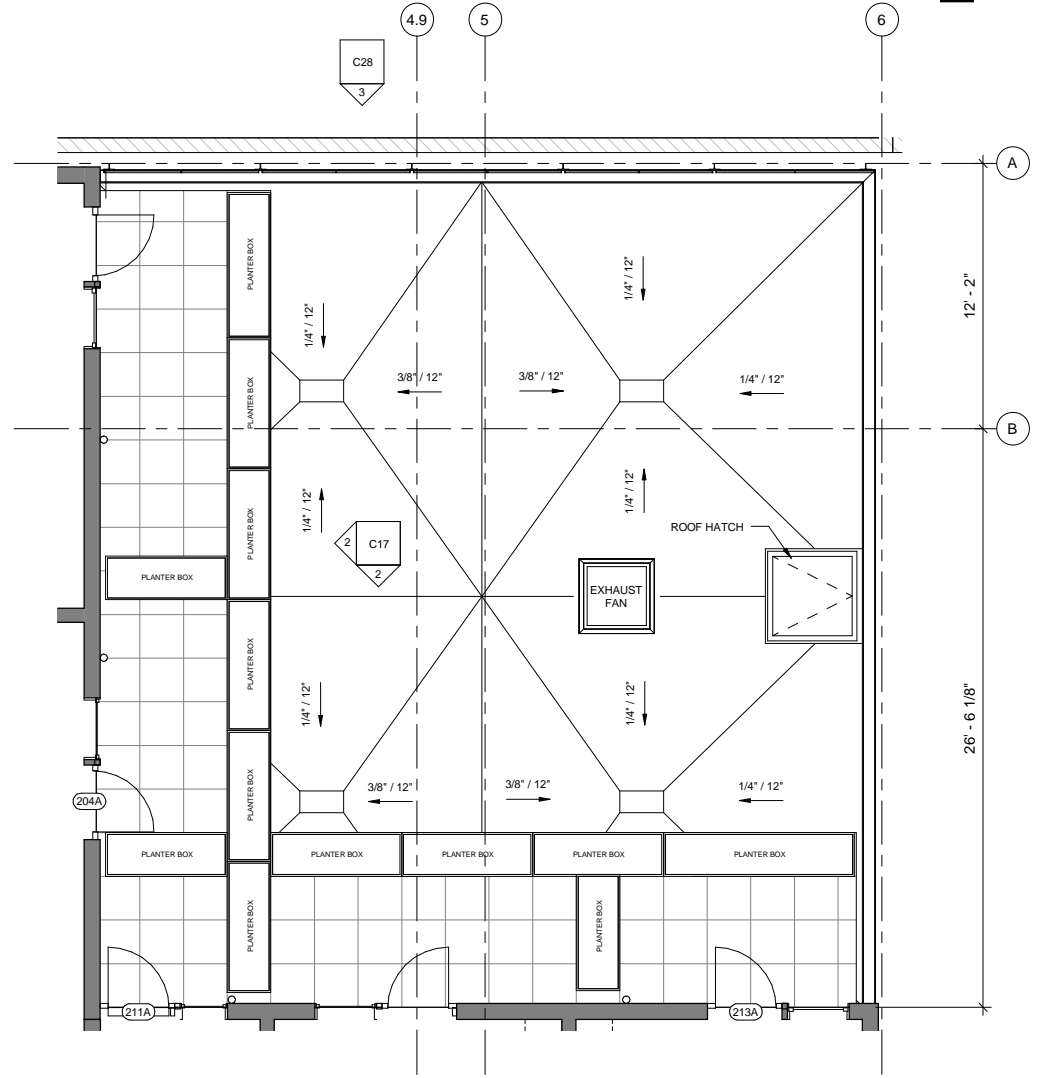

1 NE COURTYARD DETAIL PLAN
1/4" = 1'-0"

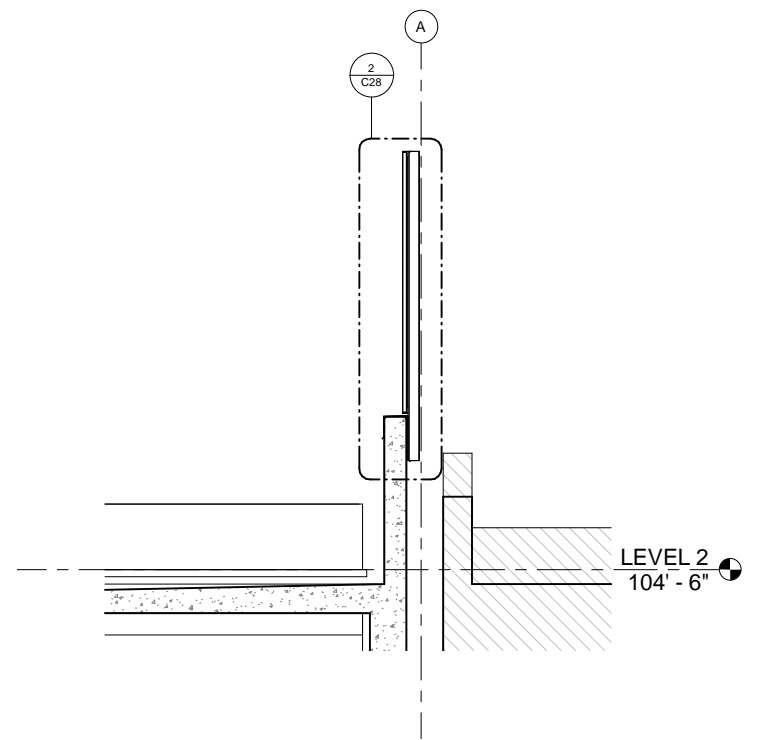

4 NE COURTYARD FENCE SECTION
1/2" = 1'-0"



VALLASTER CORL ARCHITECTS, PC
711 SW ALDER
PENTHOUSE SUITE
PORTLAND, OR 97205
PHONE : 503.228.0311
FAX : 503.228.0314
www.vcarch.com

OWNER :
LOWER BURNSIDE LOFTS, LLC.

PROJECT NAME :
LOWER BURNSIDE LOFTS
30 SE 10TH

REVISIONS :

ISSUE DATES :
FOR PERMIT (01.09.2014)

JOB NO. : 1303
DRAWN : Author
CHECKED : Checker
STATUS : PERMIT

NE COURTYARD

C28

ORIGINAL SHEET SIZE : 22"x34"

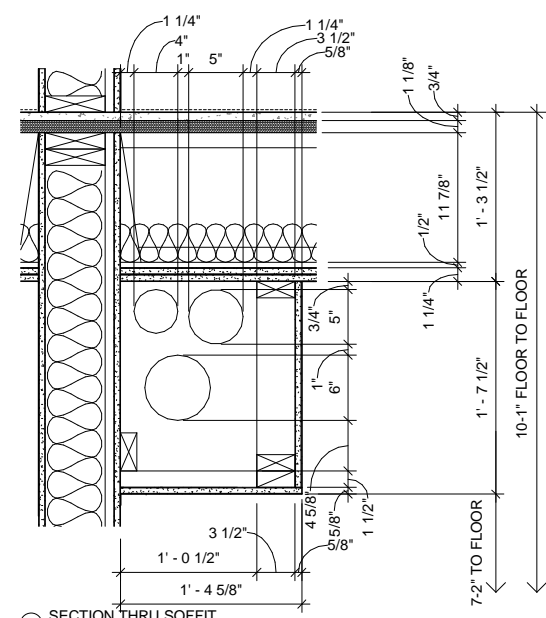

7 SECTION THRU SOFFIT
1 1/2" = 1'-0"

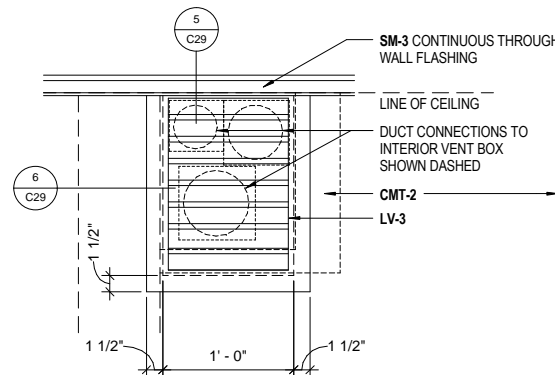

4 FIBER CEMENT - VENT ELEVATION
1 1/2" = 1'-0"

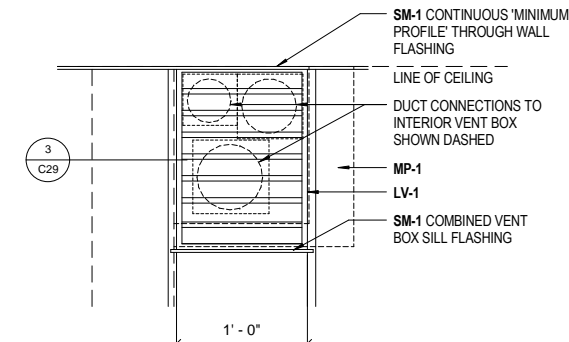

1 METAL SIDING - VENT ELEVATION
1 1/2" = 1'-0"

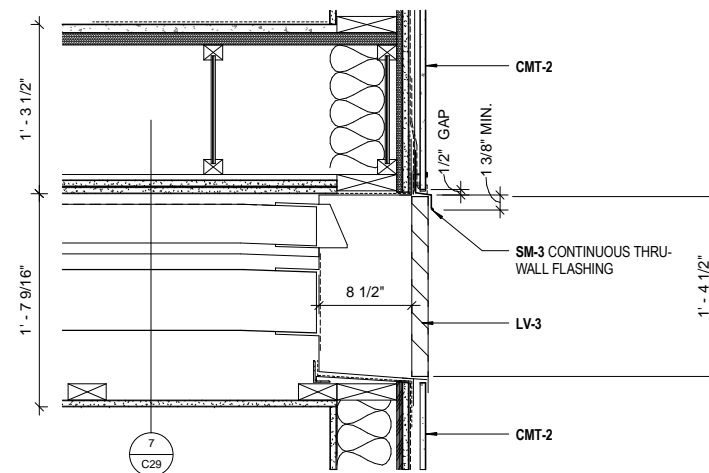

5 FIBER CEMENT - SECTION THRU VENT
1 1/2" = 1'-0"

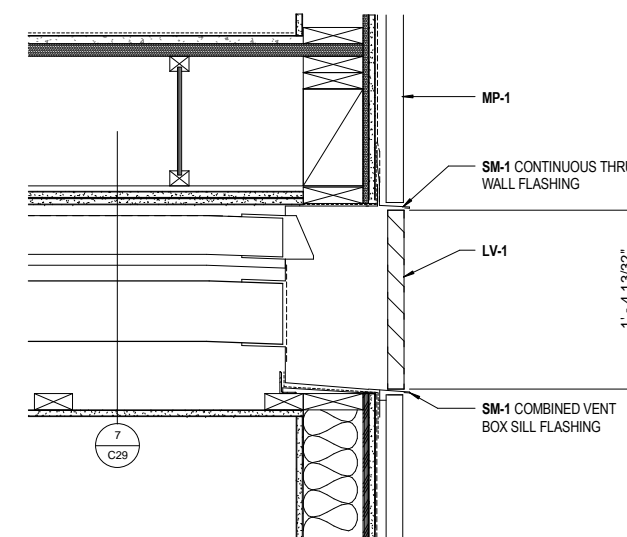

2 METAL SIDING - SECTION THRU VENT
1 1/2" = 1'-0"

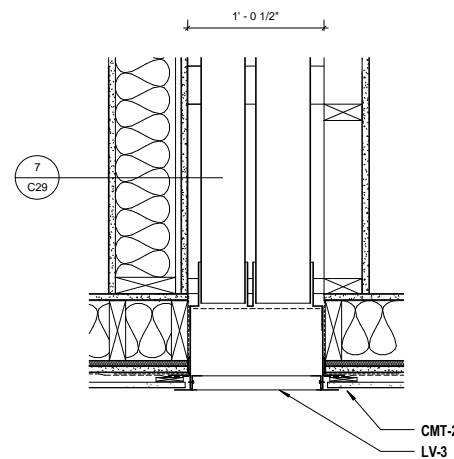

6 FIBER CEMENT - PLAN SECTION THRU VENT
1 1/2" = 1'-0"

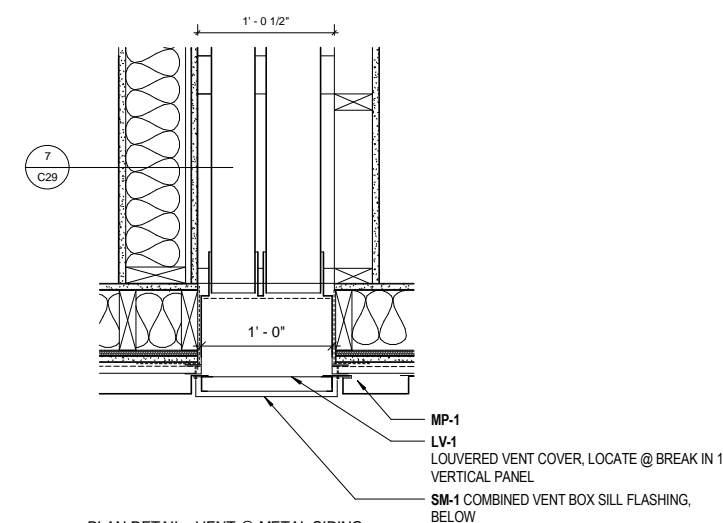

3 PLAN DETAIL - VENT @ METAL SIDING
1 1/2" = 1'-0"



VALLASTER CORL ARCHITECTS, PC
711 SW ALDER
PENTHOUSE SUITE
PORTLAND, OR 97205
PHONE : 503.228.0311
FAX : 503.228.0314
www.vcarch.com

OWNER :
LOWER BURNSIDE LOFTS, LLC.

PROJECT NAME :
LOWER BURNSIDE LOFTS
30 SE 10TH

REVISIONS :

ISSUE DATES :
FOR PERMIT (01.09.2014)

JOB NO. : 1303
DRAWN : Author
CHECKED : Checker
STATUS : PERMIT

EXTERIOR DETAILS

C29



VALLASTER CORL ARCHITECTS, PC
 711 SW ALDER
 PENTHOUSE SUITE
 PORTLAND, OR 97205
 PHONE : 503.228.0311
 FAX : 503.228.0314
 www.vcarch.com

OWNER:
 LOWER BURNSIDE LOFTS, LLC.

PROJECT NAME:
LOWER BURNSIDE LOFTS
 30 SE 10TH

REVISIONS:

ISSUE DATES:
 FOR PERMIT (01.09.2014)

JOB NO.: 1303
 DRAWN: Author
 CHECKED: Checker
 STATUS: PERMIT

EXTERIOR DETAILS

C30

5 ORIGINAL SHEET SIZE : 22"x34"

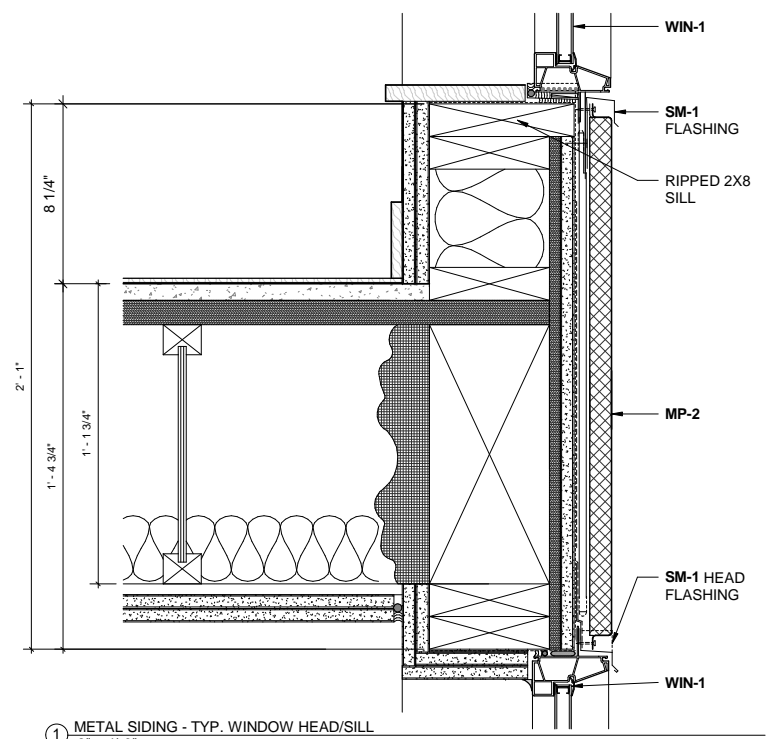

① METAL SIDING - TYP. WINDOW HEAD/SILL
 3' = 1'-0"

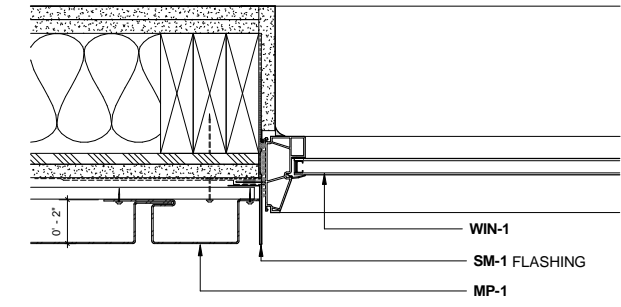

② METAL SIDING - TYPICAL WINDOW JAMB
 3' = 1'-0"

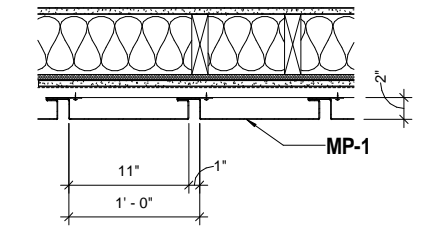

③ MP-1 PANEL TYPE 'A'
 1 1/2' = 1'-0"

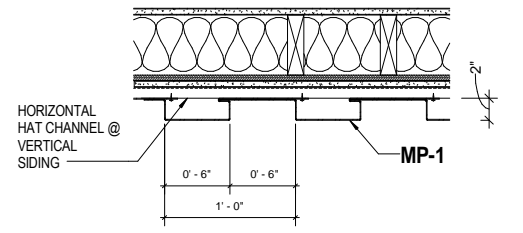

④ MP-1 PANEL TYPE 'B'
 1 1/2' = 1'-0"

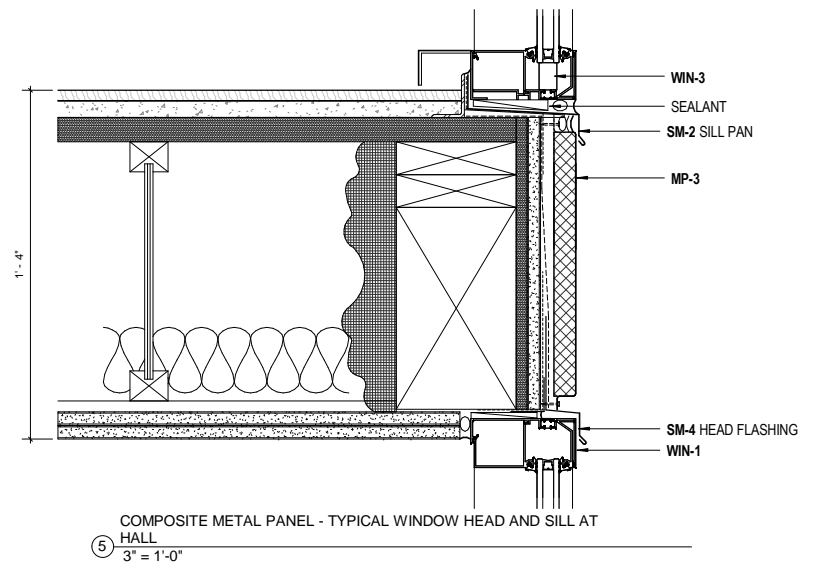

⑤ COMPOSITE METAL PANEL - TYPICAL WINDOW HEAD AND SILL AT HALL
 3' = 1'-0"

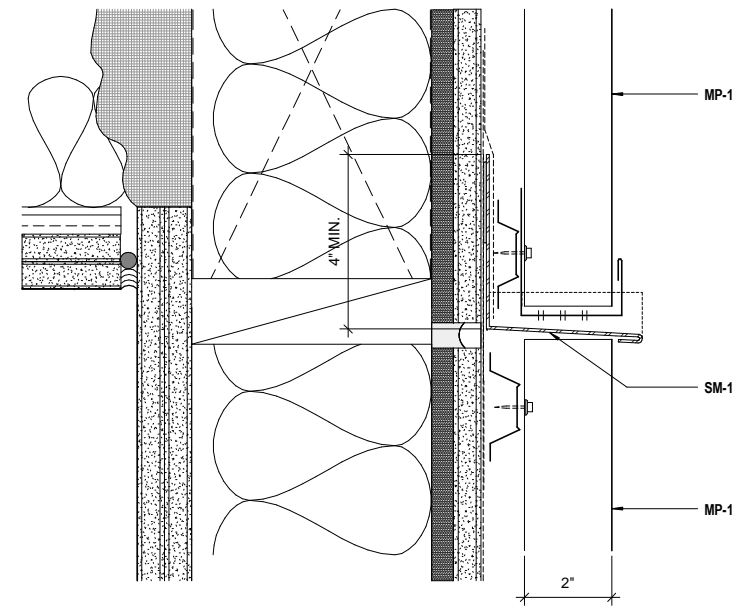

⑥ METAL SIDING - TYPICAL THRU WALL FLASHING
 6' = 1'-0"

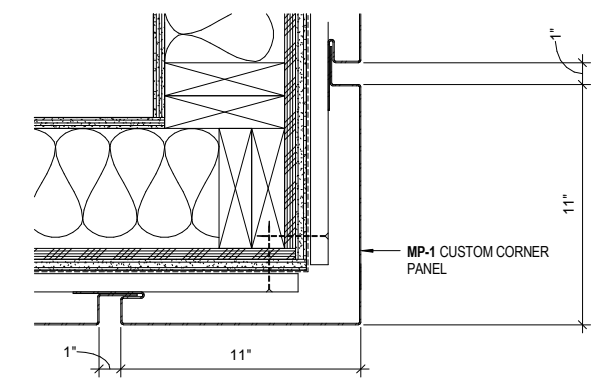

⑦ METAL SIDING - TYPICAL OUTSIDE CORNER
 3' = 1'-0"

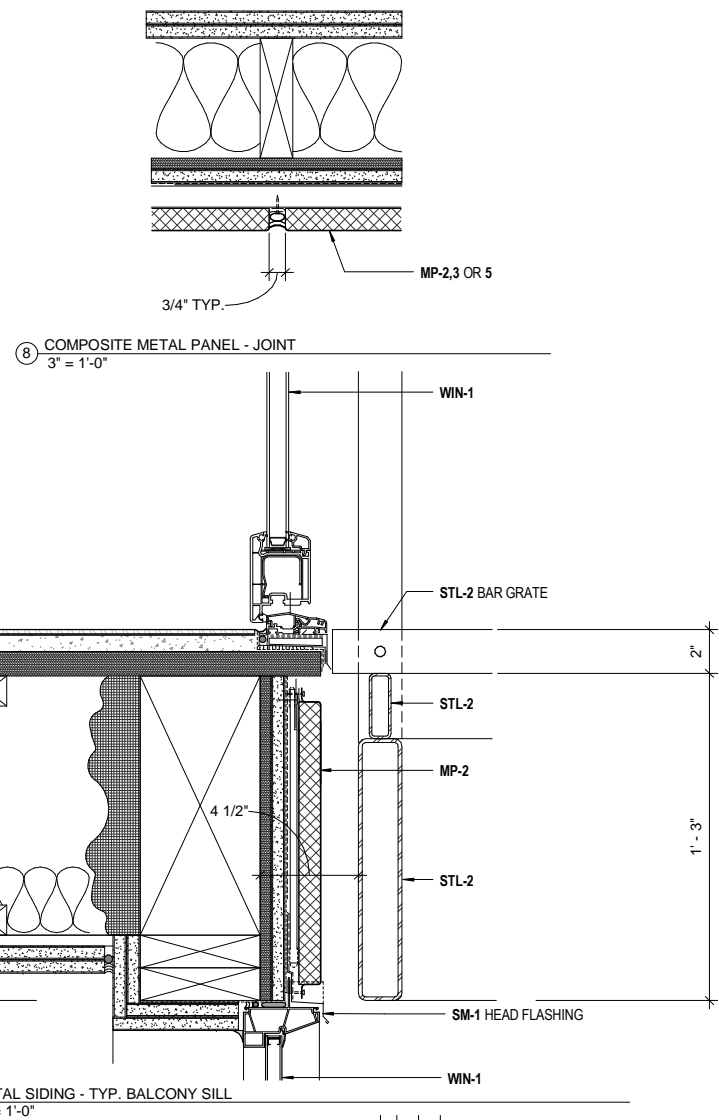

⑧ COMPOSITE METAL PANEL - JOINT
 3' = 1'-0"

⑨ METAL SIDING - TYP. BALCONY SILL
 3' = 1'-0"

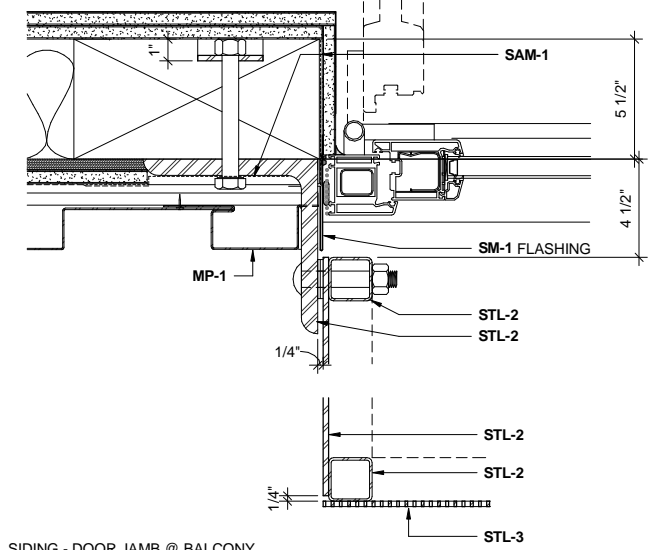

⑩ METAL SIDING - DOOR JAMB @ BALCONY
 3' = 1'-0"

0 E
 1
 2
 3
 4
 5 E

D
 D
 D
 D
 D

C
 C
 C
 C
 C

B
 B
 B
 B
 B

A
 A
 A
 A
 A

0
 1
 2
 3
 4
 5



VALLASTER CORL ARCHITECTS, PC
711 SW ALDER
PENTHOUSE SUITE
PORTLAND, OR 97205
PHONE : 503.228.0311
FAX : 503.228.0314
www.vcarch.com

OWNER :
LOWER BURNSIDE LOFTS, LLC.

PROJECT NAME :
LOWER BURNSIDE LOFTS
30 SE 10TH

REVISIONS :

ISSUE DATES :
FOR PERMIT (01.09.2014)

JOB NO. : 1303
DRAWN : Author
CHECKED : Checker
STATUS : PERMIT

EXTERIOR DETAILS
C31

ORIGINAL SHEET SIZE : 22"x34"

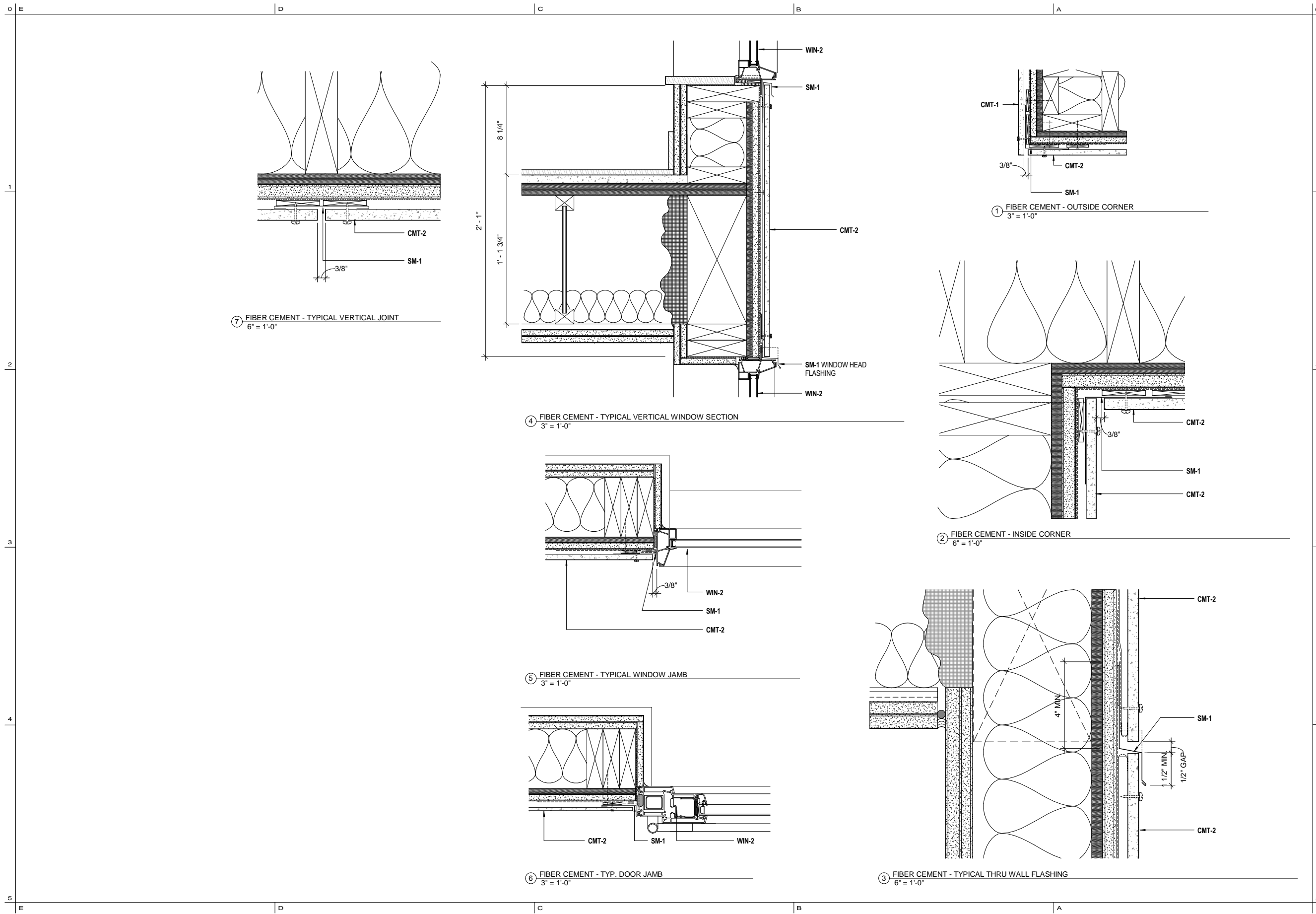

o E
1
2
3
4
5
E

D C B A
D C B A

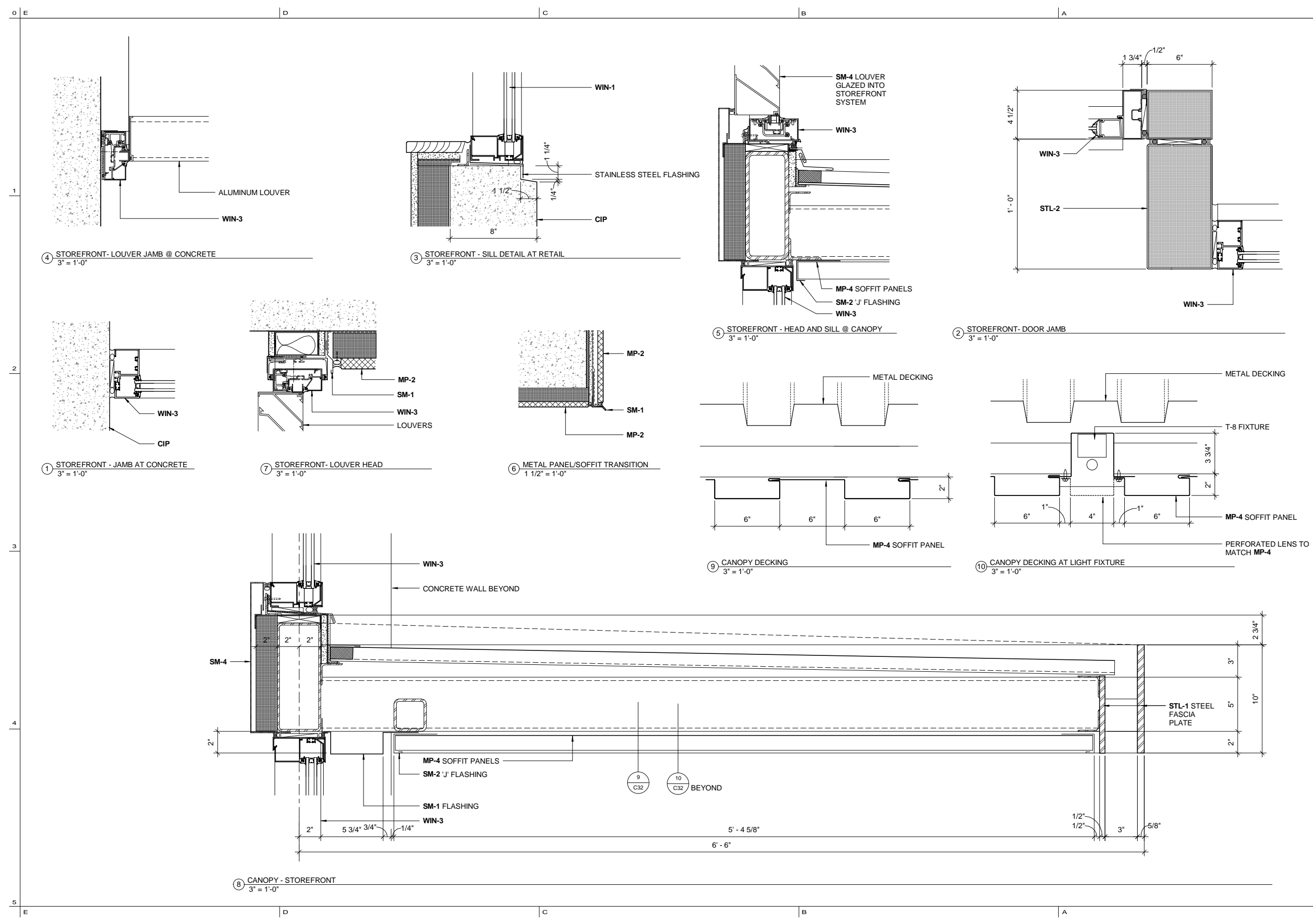

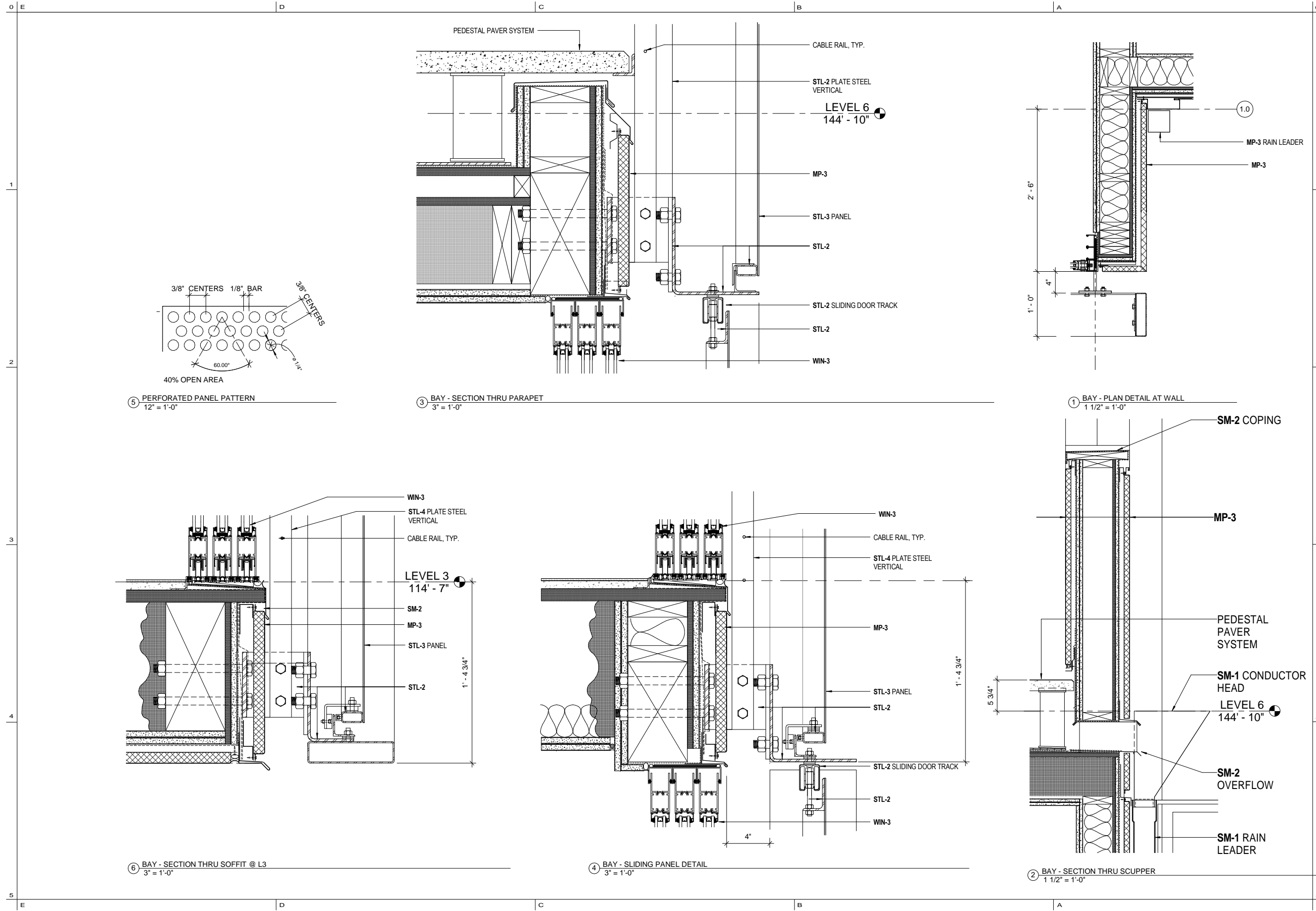

VALLASTER CORL ARCHITECTS, PC
 711 SW ALDER
 PENTHOUSE SUITE
 PORTLAND, OR 97205
 PHONE : 503.228.0311
 FAX : 503.228.0314
 www.vcarch.com

OWNER :
 LOWER BURNSIDE LOFTS, LLC.

PROJECT NAME :
LOWER BURNSIDE LOFTS
 30 SE 10TH

REVISIONS :

ISSUE DATES :
 FOR PERMIT (01.09.2014)

JOB NO. : 1303
 DRAWN : Author
 CHECKED : Checker
 STATUS : PERMIT

EXTERIOR DETAILS
C33

o | E

| D

| C

| B

| A

o

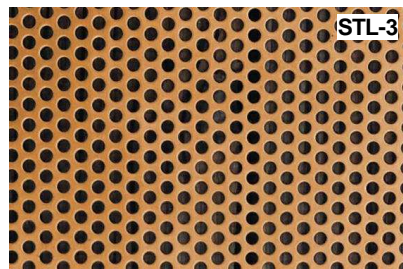
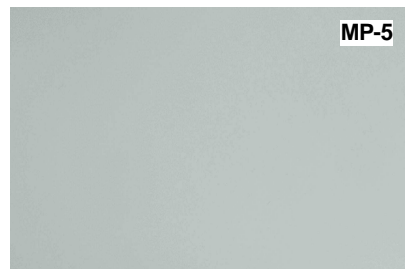
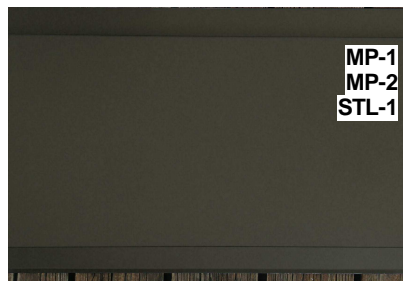
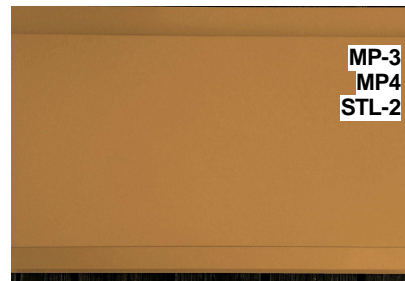

EXTERIOR MATERIALS AND FINISHES

MARK	TYPE	MANUFACTURER	PRODUCT	SIZE	COLOR	FINISH	LOCATION
CIP	CAST IN PLACE CONCRETE				NATURAL	CLEAR SEAL	LEVELS 1 & 2
CMU	CONCRETE MASONRY UNITS		NOMINAL 8X8X16		NATURAL	CLEAR SEAL	LEVEL 1 - E FACE
CMT-1	FIBER CEMENT PANEL	VIROC	INTEGRAL COLOR 1/2" THICK	PANELS UP TO 4'X10'	CHARCOAL	INTEGRAL	RESIDENTIAL SKIN - NE PROPERTY LINES
CMT-2	FIBER CEMENT PANEL	VIROC	INTEGRAL COLOR 1/2" THICK	PANELS UP TO 4'X10'	YELLOW	INTEGRAL	RESIDENTIAL SKIN - NE COURTYARD
MP-1	METAL PANEL	PIONEER S.M.	CUSTOM PROFILE 22 GA. STEEL	VARIES	DARK GREY	PAINT	RESIDENTIAL SKIN - STREETSIDE N/S/E/W
MP-2	METAL PANEL	PIONEER S.M.	FLAT PANEL W/ RIGID FOAM BACKING	VARIES	DARK GREY	PAINT	SPANDRELS, SOFFIT AT L1
MP-3	METAL PANEL	PIONEER S.M.	FLAT PANEL W/ RIGID FOAM BACKING	VARIES	ORANGE	PAINT	ROOF DECK/WINDOW SPANDREL AT END OF HALLWAYS/N REVEAL
MP-4	METAL PANEL	PIONEER S.M.	CUSTOM PROFILE 22 GA. STEEL	VARIES	ORANGE	PAINT	SOFFITS AT CANOPIES
MP-5	METAL PANEL	PIONEER S.M.	CUSTOM PROFILE 22 GA. STEEL	VARIES	SILVER TO MATCH WIN-3	PAINT	W BAY
WIN-1	VINYL WINDOWS	VPI	FIXED/CASEMENT	VARIES	SILVER	INTEGRAL COLOR	RESIDENTIAL UNITS - STREETSIDE
WIN-2	VINYL WINDOWS	VPI	FIXED/CASEMENT	VARIES	DARK GREY	INTEGRAL COLOR	RESIDENTIAL UNITS - NE COURTYARD
WIN-3	ALUMINUM STOREFRONT SYSTEM	ARCADIA	TC470		NATURAL	CLEAR ANODIZED	LEVEL 1, WEST BAY, RESIDENTIAL HALLWAYS
STL-1	STEEL			VARIES	DARK GREY	SATIN PAINT	CANOPIES
STL-2	STEEL			VARIES	ORANGE	SATIN PAINT	GUARDRAIL PANELS, BALCONY STRUCTURE, GARAGE ENTRY
STL-3	STEEL, PERFORATED			VARIES	ORANGE	SATIN PAINT	GUARDRAIL PANELS/GARAGE ENTRY
STL-4	STEEL			VARIES	SILVER	SATIN PAINT	CABLE RAIL VERTICALS AND TOP RAIL
SM-1	SHEET METAL				CHARCOAL TO MATCH MP-1	SATIN PAINT	FLASHING, DOWNSPOUTS
SM-2	SHEET METAL				ORANGE TO MATCH MP-3	SATIN PAINT	FLASHING, LOUVERS AT W BAY
SM-3	SHEET METAL				YELLOW TO MATCH CMT-2	SATIN PAINT	FLASHING
SM-4	SHEET METAL				SILVER TO MATCH WIN-3	SATIN PAINT	FLASHING
SM-4	SHEET METAL				SILVER TO MATCH WIN-1	SATIN PAINT	FLASHING, TRIM BETWEEN WIN-1
LV-1	METAL LOUVER	CUSTOM		CUSTOM	CHARCOAL TO MATCH MP-1	SATIN PAINT	BATH/DRYER EXHAUST AT W BAY STREETSIDE RESIDENTIAL
LV-2	METAL LOUVER	CUSTOM		CUSTOM	ORANGE TO MATCH MP-1	SATIN PAINT	LEVEL 1 STREETSIDE
LV-3	METAL LOUVER	CUSTOM		CUSTOM	YELLOW TO MATCH CMT-2	SATIN PAINT	BATH/DRYER EXHAUST AT NE RESIDENTIAL UNITS
LV-4	METAL LOUVER	CUSTOM		CUSTOM	METALLIC SILVER TO MATCH WIN-3	SATIN PAINT	



VALLASTER CORL ARCHITECTS, PC
 711 SW ALDER
 PENTHOUSE SUITE
 PORTLAND, OR 97205
 PHONE : 503.228.0311
 FAX : 503.228.0314
 www.vcarch.com

OWNER :
 LOWER BURNSIDE LOFTS, LLC.

PROJECT NAME :
LOWER BURNSIDE LOFTS
 30 SE 10TH

REVISIONS :

ISSUE DATES :
 FOR PERMIT (01.09.2014)

JOB NO. : 1303
 DRAWN : Author
 CHECKED : Checker
 STATUS : PERMIT

MATERIALS
C34

ORIGINAL SHEET SIZE : 22"X34"

1

2

3

4

5

1

2

3

4

5

E

D

C

B

A

o

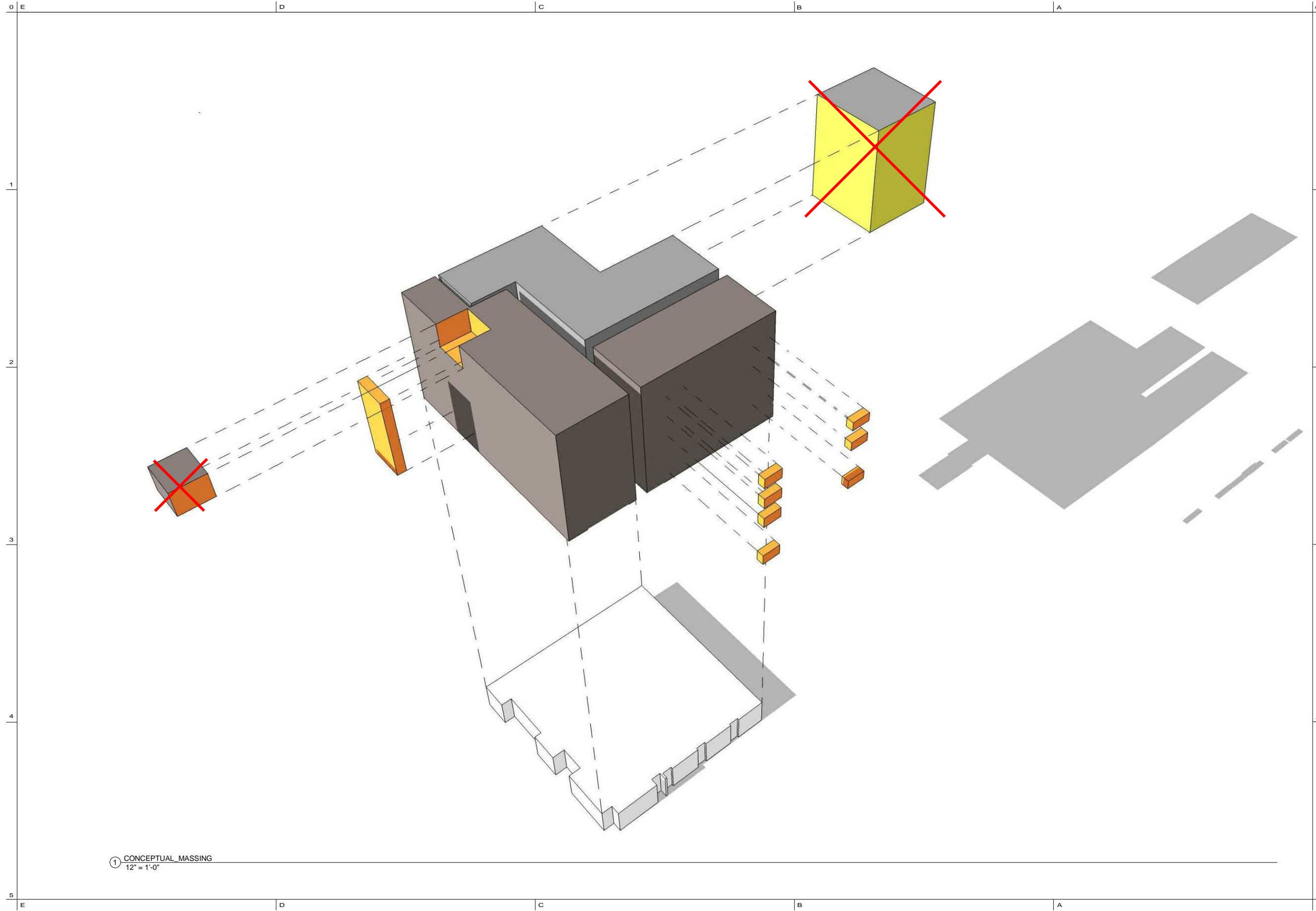

① CONCEPTUAL MASSING
1/2" = 1'-0"



VALLASTER CORL ARCHITECTS, PC
711 SW ALDER
PENTHOUSE SUITE
PORTLAND, OR 97205
PHONE : 503.228.0311
FAX : 503.228.0314
www.vcarch.com

OWNER :
LOWER BURNSIDE LOFTS, LLC.

PROJECT NAME :
LOWER BURNSIDE LOFTS
30 SE 10TH

REVISIONS :

ISSUE DATES :

FOR PERMIT (01.09.2014)

JOB NO. :	1303
DRAWN :	Author
CHECKED :	Checker
STATUS :	PERMIT

MASSING CONCEPT
C35



VALLASTER CORL ARCHITECTS, PC
 711 SW ALDER
 PENTHOUSE SUITE
 PORTLAND, OR 97205
 PHONE : 503.228.0311
 FAX : 503.228.0314
 www.vcarch.com

OWNER :
 LOWER BURNSIDE LOFTS, LLC.

PROJECT NAME :
LOWER BURNSIDE LOFTS
 30 SE 10TH

REVISIONS :

ISSUE DATES :
 FOR PERMIT (01.09.2014)

JOB NO. : 1303
 DRAWN : Author
 CHECKED : Checker
 STATUS : PERMIT

PERSPECTIVE - SW
C36

ORIGINAL SHEET SIZE : 22"X34"

0 E | D | C | B | A 0

1

2

3

4

5 E | D | C | B | A 5

0 | E

| D

| C

| B

| A

0



1

2

3

4

5

| D

| C

| B

| A

5



VALLASTER CORL ARCHITECTS, PC
 711 SW ALDER
 PENTHOUSE SUITE
 PORTLAND, OR 97205
 PHONE : 503.228.0311
 FAX : 503.228.0314
 www.vcarch.com

1

2

OWNER :
 LOWER BURNSIDE LOFTS, LLC.

PROJECT NAME :
LOWER BURNSIDE LOFTS
 30 SE 10TH

3

REVISIONS :

ISSUE DATES :
 FOR PERMIT (01.09.2014)

4

JOB NO. : 1303
 DRAWN : Author
 CHECKED : Checker
 STATUS : PERMIT

PERSPECTIVE -
 NW
C37

5 ORIGINAL SHEET SIZE : 22"X34"



VALLASTER CORL
ARCHITECTS, PC
711 SW ALDER
PENTHOUSE SUITE
PORTLAND, OR 97205
PHONE : 503.228.0311
FAX : 503.228.0314
www.vcarch.com

OWNER:
LOWER BURNSIDE LOFTS,
LLC.

PROJECT NAME:
**LOWER BURNSIDE
LOFTS**
30 SE 10TH

REVISIONS:

ISSUE DATES:
FOR PERMIT (01.09.2014)

JOB NO.: 1303
DRAWN: Author
CHECKED: Checker
STATUS: PERMIT

PERSPECTIVE -
NE
C38

ORIGINAL SHEET SIZE : 22"X34"

0 E

D

C

B

A

0

1

2

3

4

5



VALLASTER CORL ARCHITECTS, PC
 711 SW ALDER
 PENTHOUSE SUITE
 PORTLAND, OR 97205
 PHONE : 503.228.0311
 FAX : 503.228.0314
 www.vcarch.com

1

2

OWNER :
 LOWER BURNSIDE LOFTS, LLC.

PROJECT NAME :
LOWER BURNSIDE LOFTS
 30 SE 10TH

3

REVISIONS :

ISSUE DATES :
 FOR PERMIT (01.09.2014)

4

JOB NO. : 1303
 DRAWN : Author
 CHECKED : Checker
 STATUS : PERMIT

PERSPECTIVE - SE
C39

5 ORIGINAL SHEET SIZE : 22"X34"

D

C

B

A

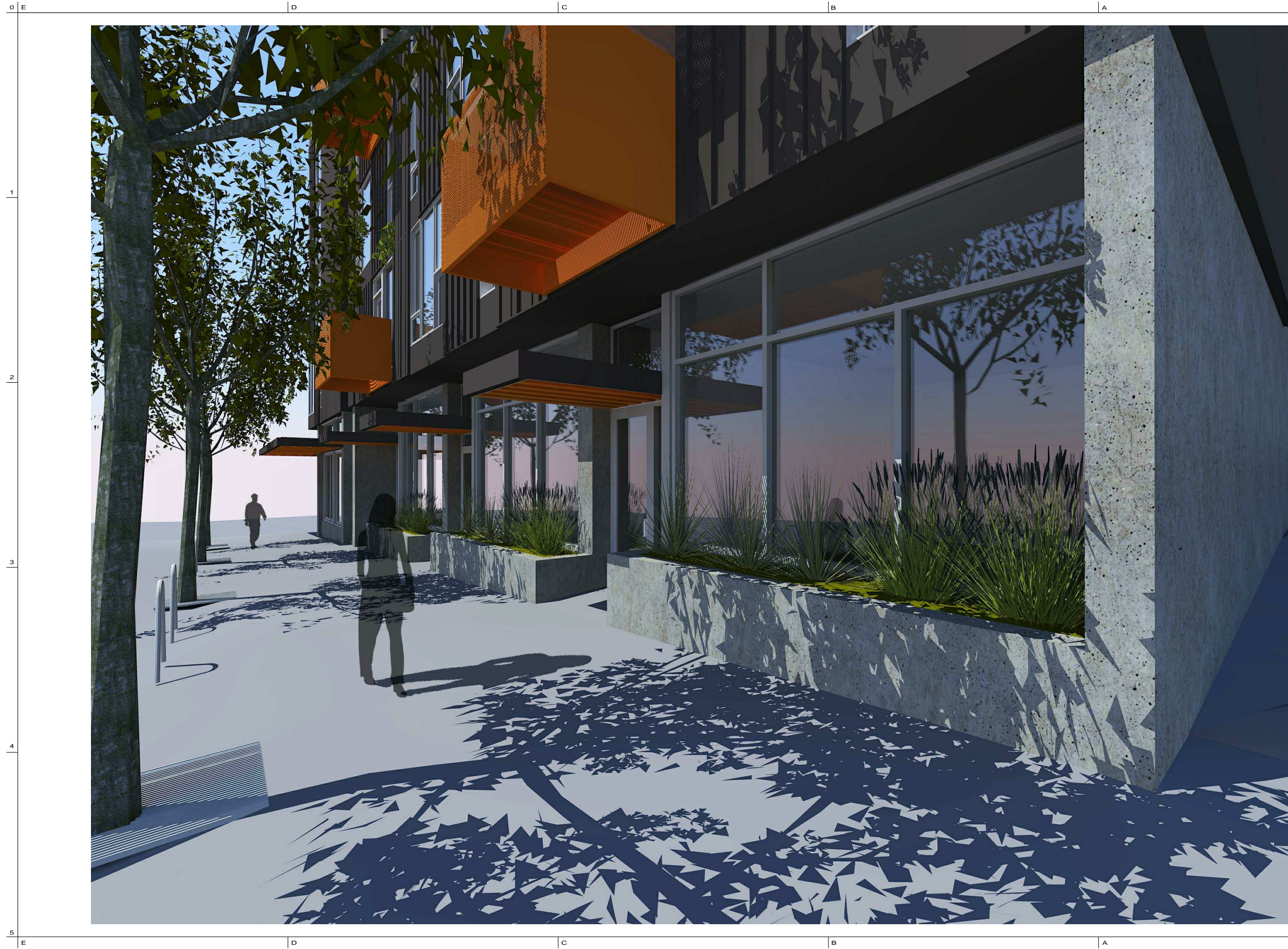

VALLASTER CORL ARCHITECTS, PC
 711 SW ALDER
 PENTHOUSE SUITE
 PORTLAND, OR 97205
 PHONE : 503.228.0311
 FAX : 503.228.0314
 www.vcarch.com

OWNER :
 LOWER BURNSIDE LOFTS, LLC.

PROJECT NAME :
LOWER BURNSIDE LOFTS
 30 SE 10TH

REVISIONS :

ISSUE DATES :
 FOR PERMIT (01.09.2014)

JOB NO. : 1303
 DRAWN : Author
 CHECKED : Checker
 STATUS : PERMIT

PERSPECTIVE - RETAIL FROM SE
C40

ORIGINAL SHEET SIZE : 22"x34"



VALLASTER CORL ARCHITECTS, PC
 711 SW ALDER
 PENTHOUSE SUITE
 PORTLAND, OR 97205
 PHONE : 503.228.0311
 FAX : 503.228.0314
 www.vcarch.com

OWNER :
 LOWER BURNSIDE LOFTS, LLC.

PROJECT NAME :
LOWER BURNSIDE LOFTS
 30 SE 10TH

REVISIONS :

ISSUE DATES :
 FOR PERMIT (01.09.2014)

JOB NO. : 1303
 DRAWN : Author
 CHECKED : Checker
 STATUS : PERMIT

PERSPECTIVE - GARAGE ENTRY
C41

ORIGINAL SHEET SIZE : 22"x34"

o | E

| D

| C

| B

| A

o

1

2

3

4

5

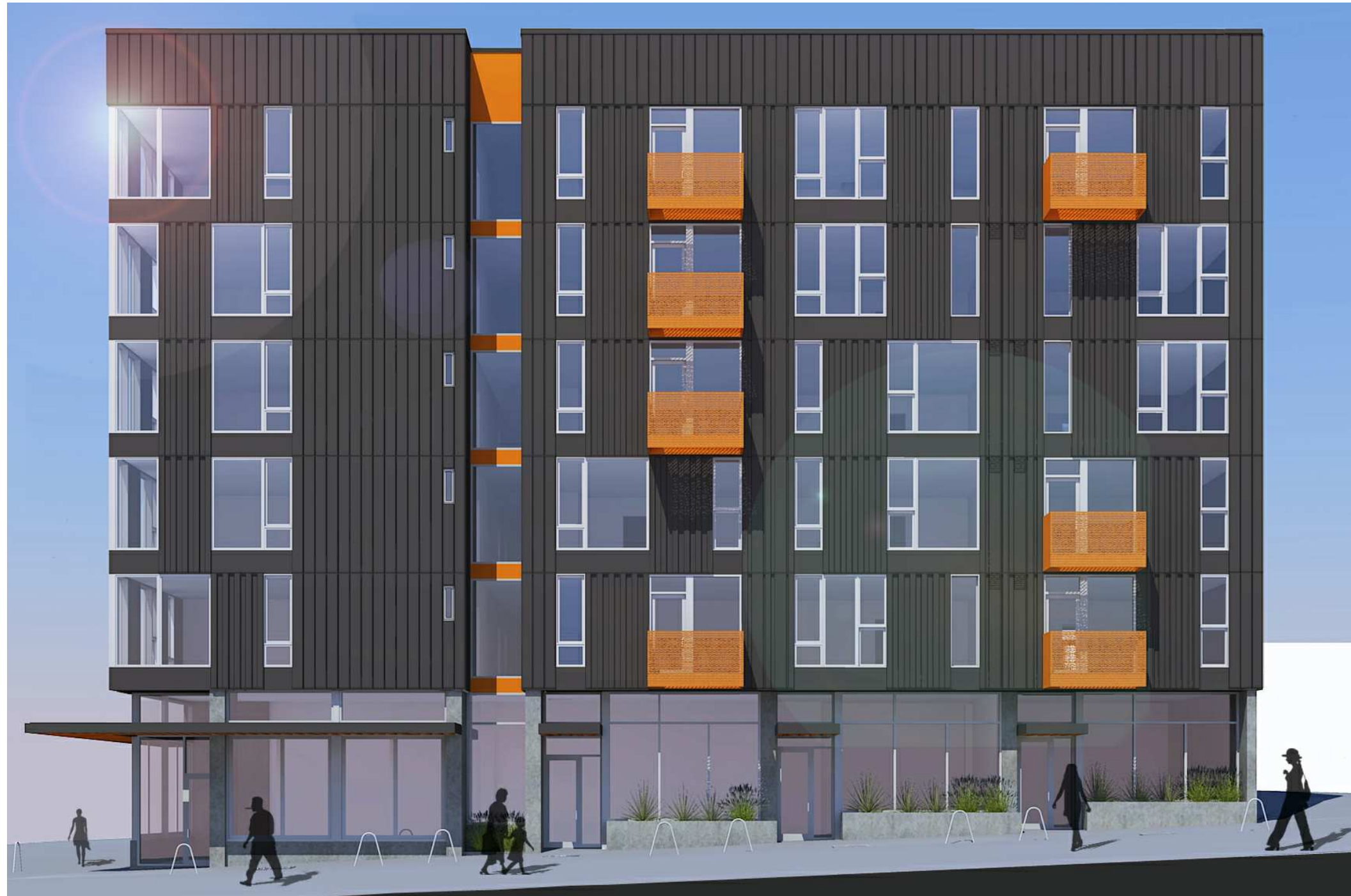

VALLASTER CORL ARCHITECTS, PC
 711 SW ALDER
 PENTHOUSE SUITE
 PORTLAND, OR 97205
 PHONE : 503.228.0311
 FAX : 503.228.0314
 www.vcarch.com

1

2

3

4

5

OWNER :
 LOWER BURNSIDE LOFTS, LLC.

PROJECT NAME :
LOWER BURNSIDE LOFTS
 30 SE 10TH

REVISIONS :

ISSUE DATES :
 FOR PERMIT (01.09.2013)

JOB NO. : 1303
 DRAWN : Author
 CHECKED : Checker
 STATUS : PERMIT

PERSPECTIVE -
 S
C42

ORIGINAL SHEET SIZE : 22"x34"

0 | E

| D

| C

| B

| A

0

1

2

3

4

5

| D

| C

| B

| A

5



**VALLASTER CORL
ARCHITECTS, PC**
711 SW ALDER
PENTHOUSE SUITE
PORTLAND, OR 97205
PHONE : 503.228.0311
FAX : 503.228.0314
www.vcarch.com

1

2

3

4

OWNER :
LOWER BURNSIDE LOFTS,
LLC.

PROJECT NAME :
**LOWER BURNSIDE
LOFTS**
30 SE 10TH

REVISIONS :

ISSUE DATES :
FOR PERMIT (01.09.2013)

JOB NO. : 1303
DRAWN : Author
CHECKED : Checker
STATUS : PERMIT

PERSPECTIVE -
W
C43

5 ORIGINAL SHEET SIZE : 22"X34"