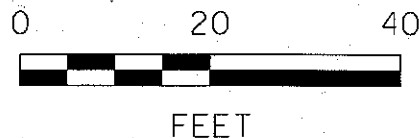
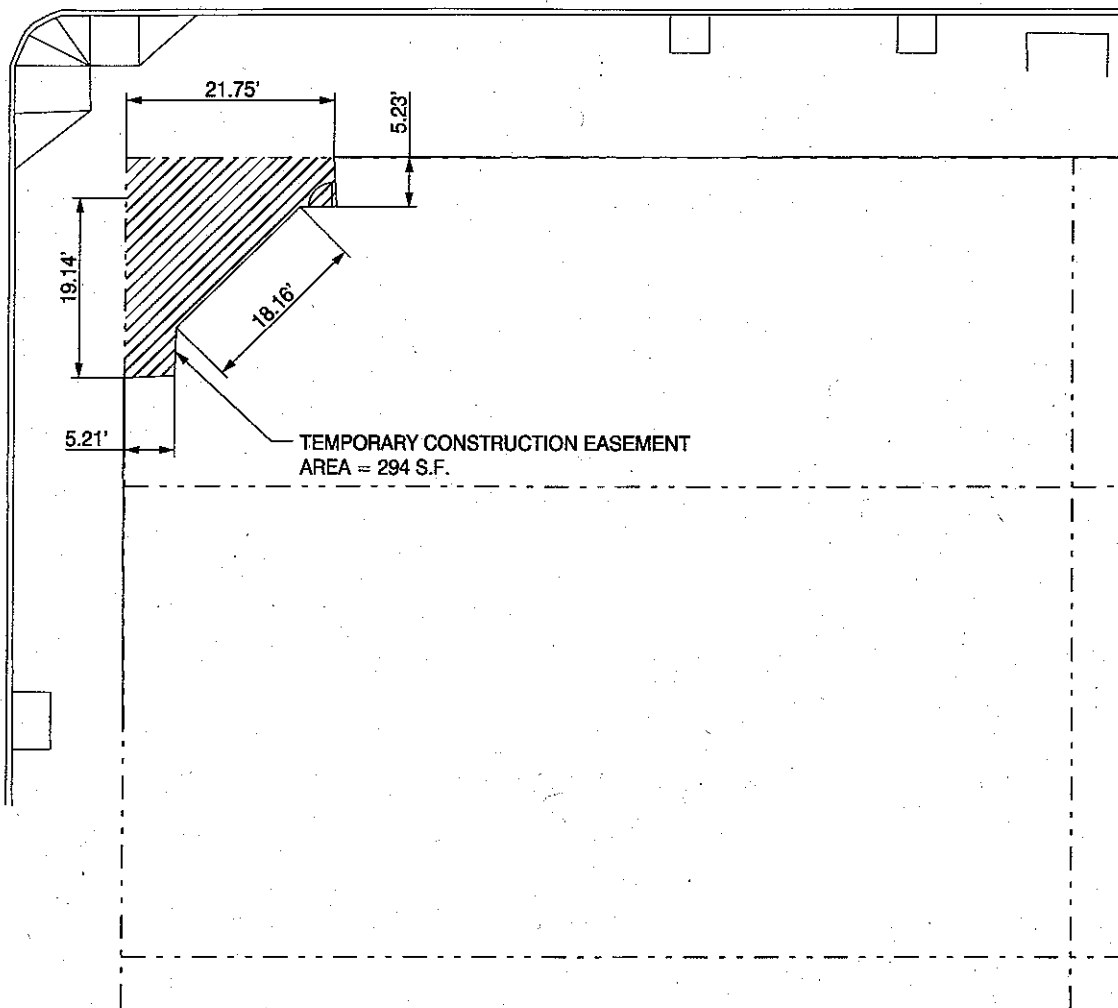

EXHIBIT 1

E. BURNSIDE ST.

S.E. ML KING JR. BLVD.



ROW FILE NO. 5
TAX LOT 1N1E35CC 2600

| | | |
|--|---------------------------------|---------------|
| CHECKED BY <i>RDP</i> | DESIGNED BY <i>HHPR TEAM</i> | DATE APPROVED |
| PROJECT NO. 37642 | CAD BY <i>HHPR CAD</i> | DIV ENGINEER |
| | 1/SECTION #### | |
| FHWA PROJECT NUMBER X-CM-XXXX-(PDX) | | |



Harper Houf Peterson Righellis Inc.
ENGINEERS • PLANNERS
LANDSCAPE ARCHITECTS • SURVEYORS
205 SE Spokane Street, Suite 200, Portland, OR 97202
phone: 503.221.1131 www.hhpr.com fax: 503.221.1171

APPROVALS:

| | |
|-------------------|------------------------------|
| DIVISION ENGINEER | REG. PROF. ENGR. NO. 51538PE |
| CITY ENGINEER | REG. PROF. ENGR. NO. 51538PE |

CITY OF PORTLAND OFFICE OF TRANSPORTATION
SAM ADAMS
STEVE TOWNSEN, P.E.
COMMISSIONER
CITY ENGINEER

**Temporary Construction Easement
400 E. BURNSIDE ST.**
NE 3RD AVE - NE 14TH AVE (PORTLAND) SEC.
E BURNSIDE - NE COUCH COUPLET

SHEET NO. **1**

EXHIBIT 2

E. BURNSIDE ST.

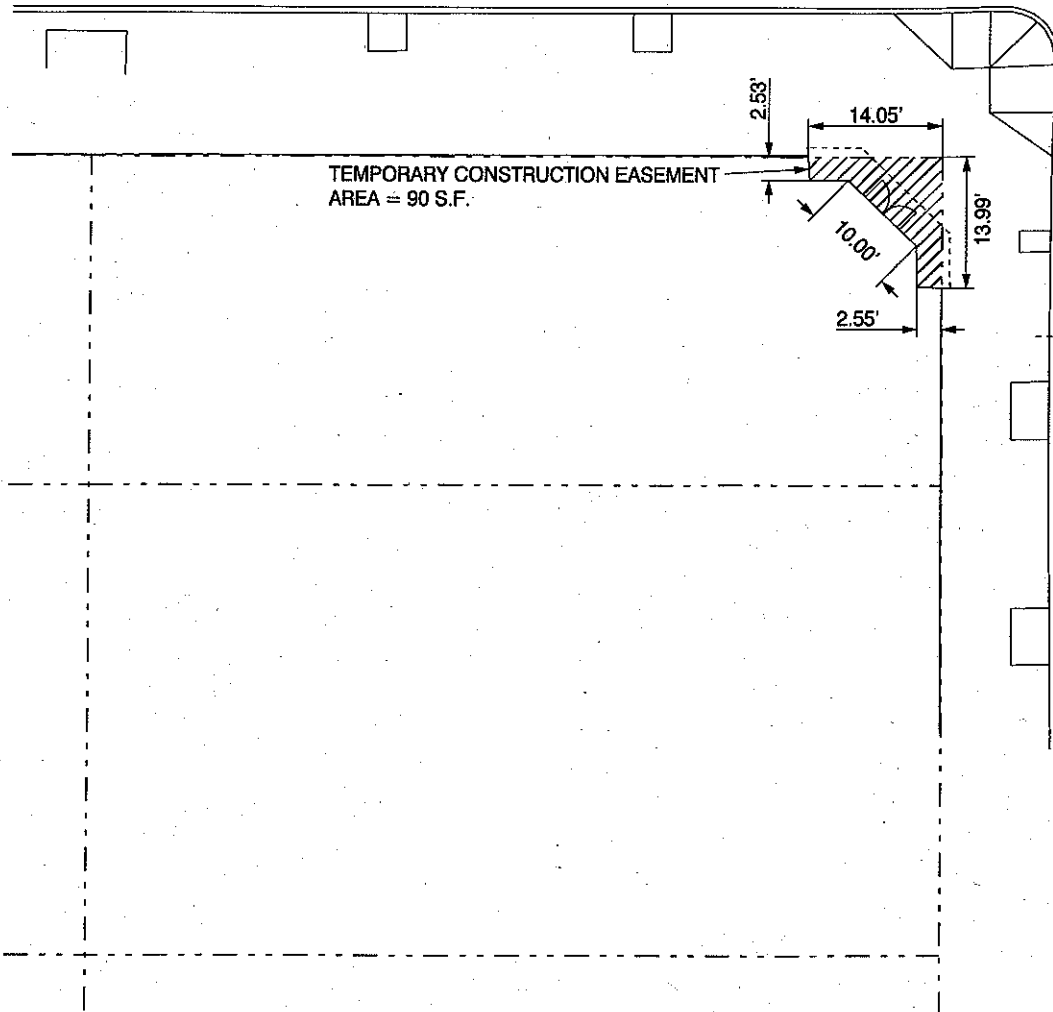

S.E GRAND AVE.



ROW FILE NO. 6
TAX LOT 1N1E35CC 2200

| | | | | |
|----------|------|--|---------------------------------|---------------|
| | | CHECKED BY <i>RDP</i> | DESIGNED BY <i>HHPR TEAM</i> | DATE APPROVED |
| | | | CAD BY <i>HHPR CAD</i> | DIY ENGINEER |
| | | PROJECT NO. 37642 | SECTION #### | |
| | | FHWA PROJECT NUMBER X-CM-XXXX-(PDX) | | |
| NO. | DATE | DESCRIPTION | APPD. | |
| REVISION | | | | |



Harper Houf Peterson Righellis Inc.
ENGINEERS • PLANNERS
LANDSCAPE ARCHITECTS • SURVEYORS
205 SE Spokane Street, Suite 200, Portland, OR 97202
phone: 503.221.1131 www.hhpr.com fax: 503.221.1171

APPROVALS:

| | |
|-------------------|------------------------------|
| DIVISION ENGINEER | REG. PROF. ENGR. NO. 51538PE |
| CITY ENGINEER | REG. PROF. ENGR. NO. 51538PE |

CITY OF PORTLAND
OFFICE OF
TRANSPORTATION

SAM ADAMS
STEVE TOWNSEN, P.E.

COMMISSIONER
CITY ENGINEER

Temporary Construction Easement
400 E. BURNSIDE ST.

NE 3RD AVE - NE 14TH AVE (PORTLAND) SEC
E BURNSIDE - NE COUCH COUPLET

SHEET NO. **1**

EXHIBIT 3

E. BURNSIDE ST.

S.E. GRAND AVE.

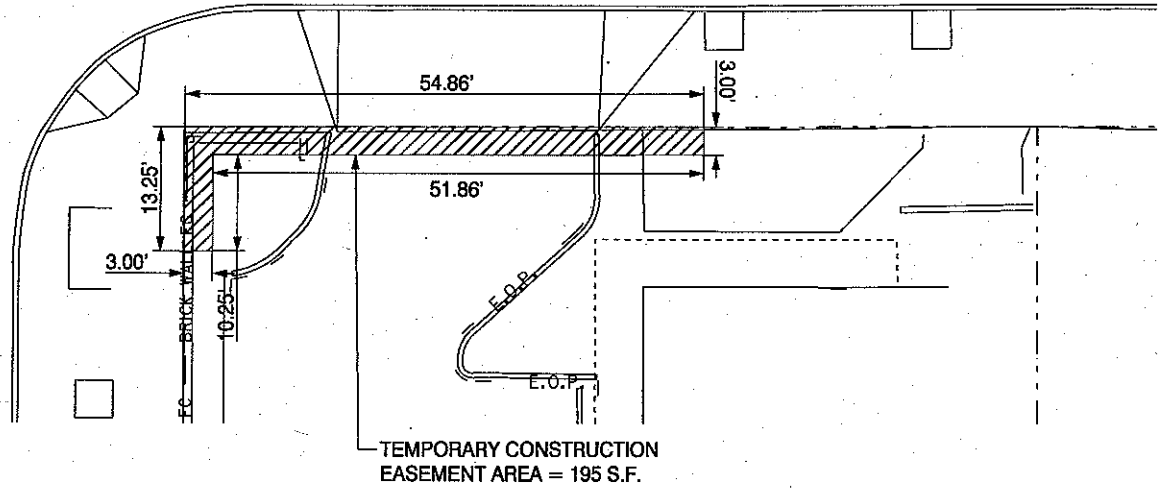

TEMPORARY CONSTRUCTION
EASEMENT AREA = 195 S.F.

ROW FILE NO. 7
TAX LOT 1N1E35CC 2100



| | | | | |
|----------------------------|--|--|---------------------------------|---------------|
| | | CHECKED BY <i>RDP</i> | DESIGNED BY <i>HHPR TEAM</i> | DATE APPROVED |
| | | | CAD BY <i>HHPR CAD</i> | DIV ENGINEER |
| | | PROJECT NO. 37642 | SECTION ### | |
| NO. DATE DESCRIPTION APPD. | | FHWA PROJECT NUMBER X-CM-XXXX-(PDX) | | |
| REVISION | | | | |



**Harper
Houf Peterson
Righellis Inc.**
ENGINEERS • PLANNERS
LANDSCAPE ARCHITECTS • SURVEYORS
205 SE Spokane Street, Suite 200, Portland, OR 97202
phone: 503.221.1131 www.hhpr.com fax: 503.221.1171

APPROVALS:

DIVISION ENGINEER _____ REG. PROF. ENGR. NO. 5153BPE

CITY ENGINEER _____ REG. PROF. ENCR. NO. 5153BPE

**CITY OF PORTLAND
OFFICE OF
TRANSPORTATION**

SAM ADAMS
STEVE TOWNSEN, P.E.

COMMISSIONER
CITY ENGINEER

**Temporary Construction Easement
412 N.E. GRAND AVE.**

NE 3RD AVE - NE 14TH AVE (PORTLAND) SEC

E BURNSIDE - NE COUCH COUPLET

SHEET NO. **1**

E. BURNSIDE ST.

N.E. 6TH AVE.

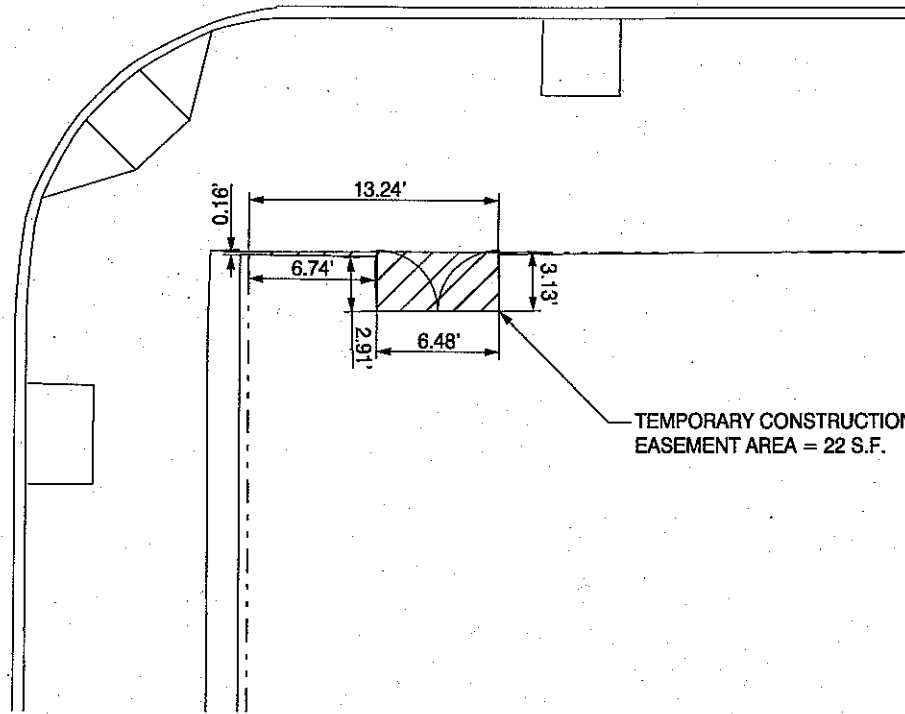

TEMPORARY CONSTRUCTION
EASEMENT AREA = 22 S.F.

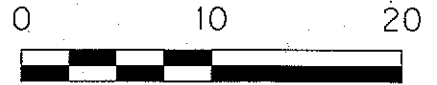

FEET

ROW FILE NO. 9
TAX LOT 1N1E35CC 1600

| | | | | | | |
|-----|------|-------------|-------|--|--------------------------|---------------|
| | | | | CHECKED BY ADP | DESIGNED BY HHPR TEAM | DATE APPROVED |
| | | | | | CAD BY HHPR CAD | DIV ENGINEER |
| | | | | PROJECT NO. 37642 | 1/4 SECTION #### | |
| | | | | FHWA PROJECT NUMBER X-CM-XXXX-(PDX) | | |
| NO. | DATE | DESCRIPTION | APPD. | | | |
| | | REVISION | | | | |



**Harper
Houf Peterson
Righellis Inc.**
ENGINEERS • PLANNERS
LANDSCAPE ARCHITECTS • SURVEYORS
205 SE Spokane Street, Suite 200, Portland, OR 97202
phone: 503.221.1131 www.hhpr.com fax: 503.221.1171

APPROVALS:

DIVISION ENGINEER _____ REG. PROF. ENGR. NO. 51538PE

CITY ENGINEER _____ REG. PROF. ENGR. NO. 51538PE

**CITY OF
PORTLAND
OFFICE OF
TRANSPORTATION**

SAM ADAMS
STEVE TOWNSEN, P.E.

COMMISSIONER
CITY ENGINEER

**Temporary Construction Easement
600 E. BURNSIDE ST.**

NE 3RD AVE - NE 14TH AVE (PORTLAND) SEC
E BURNSIDE - NE COUCH COUPLER

SHEET NO.
1

EXHIBIT 5

E. BURNSIDE ST.

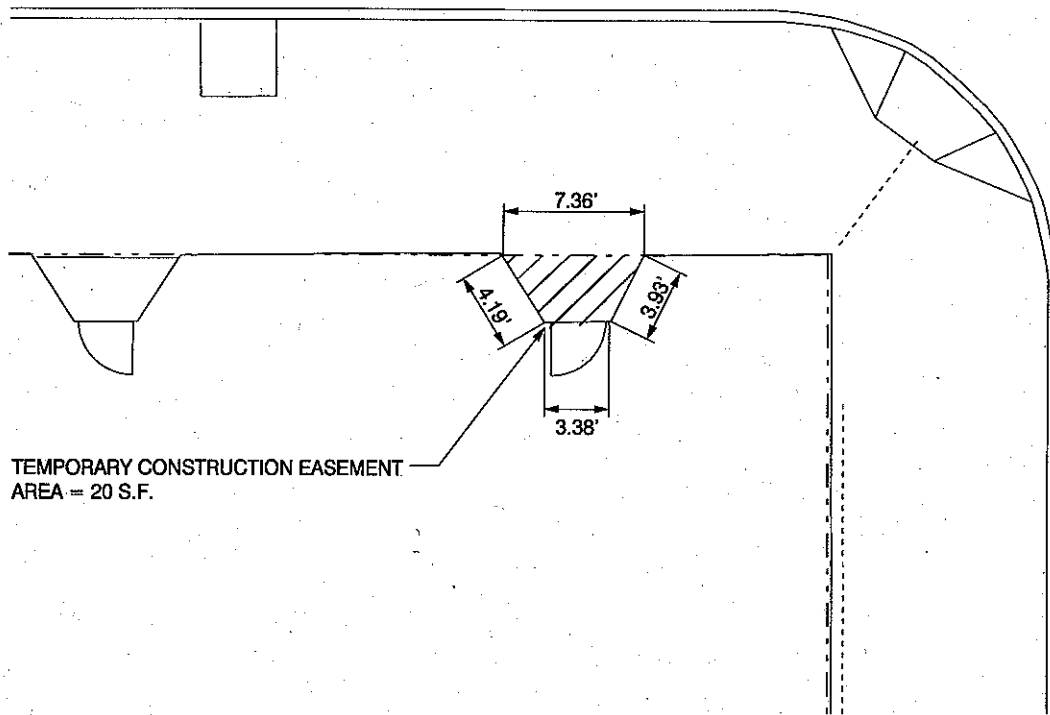

TEMPORARY CONSTRUCTION EASEMENT
AREA = 20 S.F.

S.E. 7TH AVE.

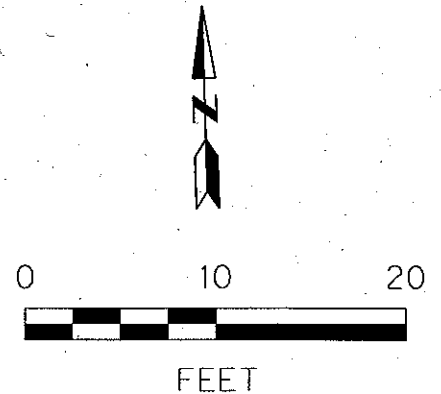

ROW FILE NO. 11
TAX LOT 1N1E35CC 1000

| NO. | DATE | DESCRIPTION | APPD. | CHECKED BY | DESIGNED BY | DATE APPROVED |
|----------|------|-------------|-------|--|-------------|---------------|
| | | | | RDP | HHPR TEAM | |
| | | | | | HHPR CAD | |
| | | | | | ### | |
| REVISION | | | | FWWA PROJECT NUMBER X-CM-XXXX-(PDX) | | |



Harper Houf Peterson Righellis Inc.
ENGINEERS • PLANNERS
LANDSCAPE ARCHITECTS • SURVEYORS
205 SE Spokane Street, Suite 200, Portland, OR 97202
phone: 503.221.1131, www.hhpr.com fax: 503.221.1171

APPROVALS:

DIVISION ENGINEER _____ REG. PROF. ENGR. NO. 51538PE

CITY ENGINEER _____ REG. PROF. ENCR. NO. 51538PE

CITY OF PORTLAND
OFFICE OF
TRANSPORTATION

SAM ADAMS
STEVE TOWNSEN, P.E.

COMMISSIONER
CITY ENGINEER

Temporary Construction Easement
624-638 E. BURNSIDE ST.

NE 3RD AVE - NE 14TH AVE (PORTLAND) SEC
E BURNSIDE - NE COUCH COUPLER

SHEET NO. **1**

EXHIBIT 6

E. BURNSIDE ST.

S.E. 7TH AVE.

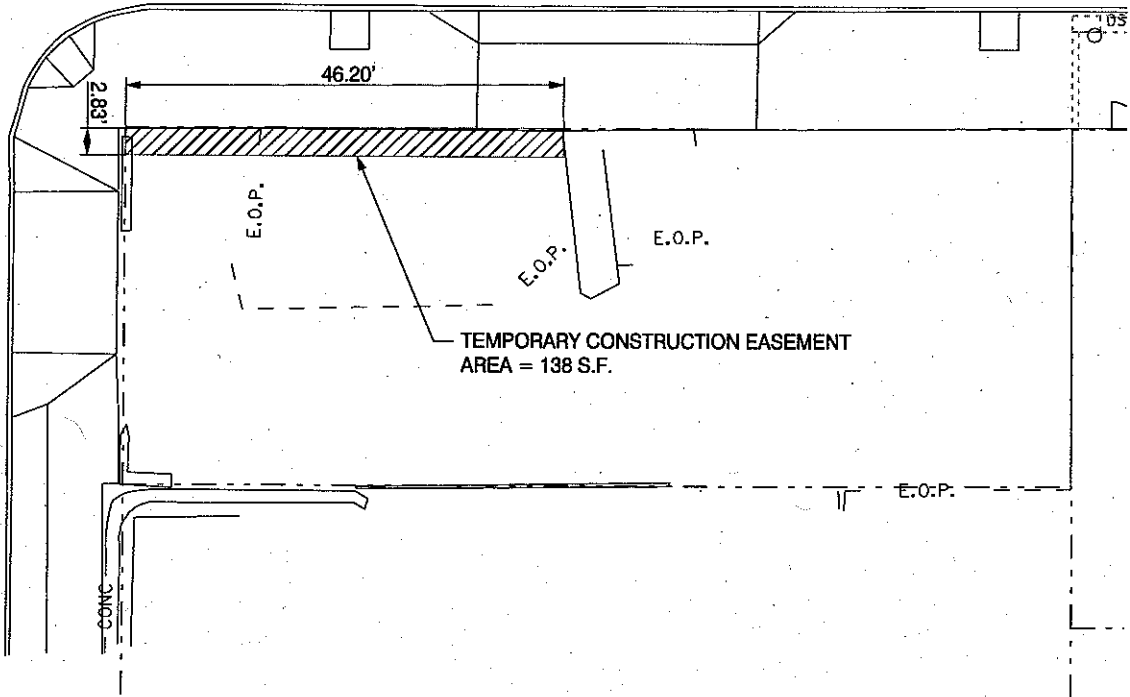

ROW FILE NO. 12
TAX LOT 1N1E35CC 900

| | | | | |
|-----|------|--|--------------------------|---------------|
| | | CHECKED BY RDP | DESIGNED BY HHPR TEAM | DATE APPROVED |
| | | | CAD BY HHPR CAD | DIV ENGINEER |
| | | PROJECT NO. 37642 | %SECTION ### | |
| | | FHWA PROJECT NUMBER X-CM-XXXX-(PDX) | | |
| NO. | DATE | DESCRIPTION | APPD. | |
| | | REVISION | | |



Harper Houf Peterson Righellis Inc.
ENGINEERS • PLANNERS
LANDSCAPE ARCHITECTS • SURVEYORS
205 SE Spokane Street, Suite 200, Portland, OR 97202
phone: 503.221.1131 www.hhpr.com fax: 503.221.1171

APPROVALS:

| | |
|-------------------|------------------------------|
| DIVISION ENGINEER | REG. PROF. ENGR. NO. 51538PE |
| CITY ENGINEER | REG. PROF. ENGR. NO. 51538PE |

CITY OF PORTLAND
OFFICE OF
TRANSPORTATION

SAM ADAMS
STEVE TOWNSEN, P.E.

COMMISSIONER
CITY ENGINEER

Temporary Construction Easement
710 E. BURNSIDE ST.

NE 3RD AVE - NE 14TH AVE (PORTLAND) SEC
E BURNSIDE - NE COUCH COUPLET

SHEET NO. **1**

EXHIBIT 7

E. BURNSIDE ST.

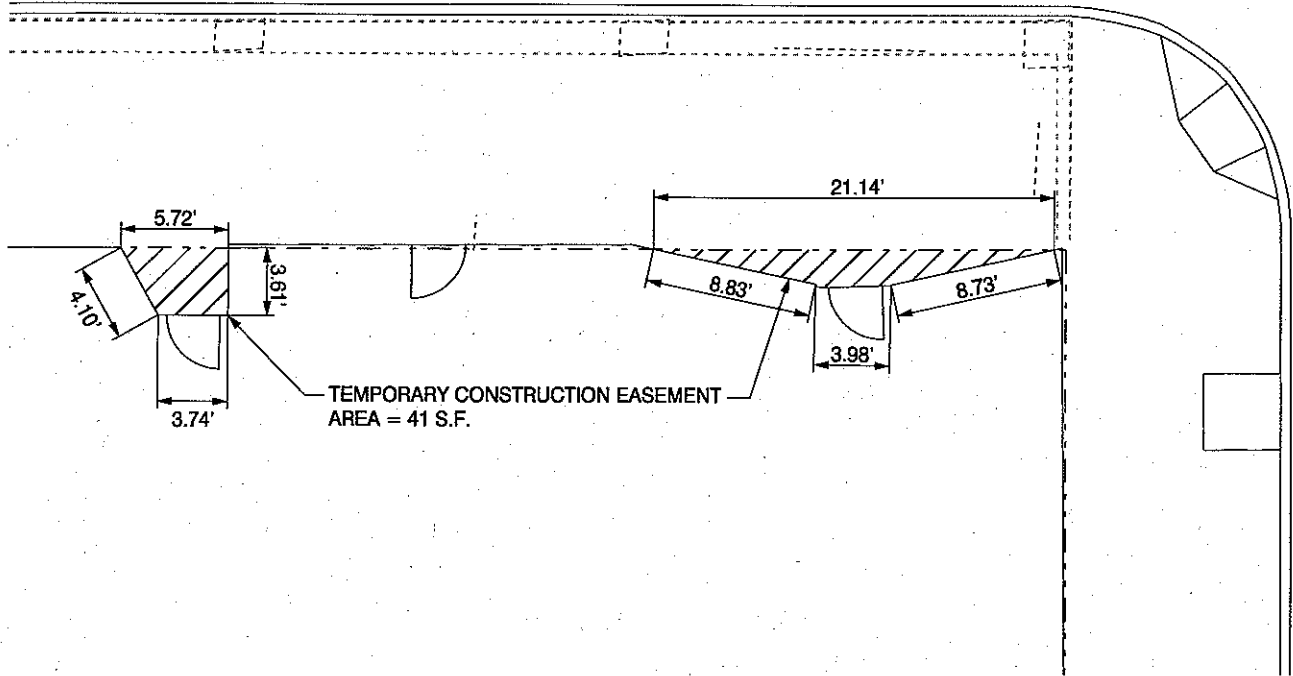

S.E. 8TH AVE.

ROW FILE NO. 13
TAX LOT 1N1E35CC 300

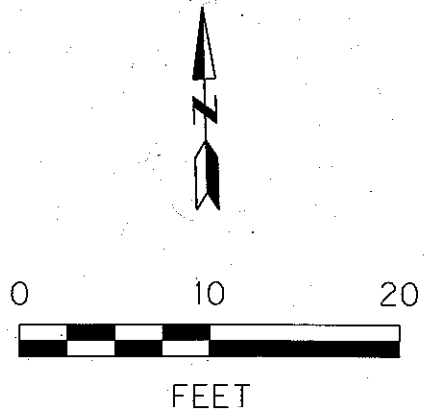

| | | | | |
|-----|------|---|---------------------------------|---------------|
| | | CHECKED BY <i>ADP</i> | DESIGNED BY <i>HHPR TEAM</i> | DATE APPROVED |
| | | | CAD BY <i>HHPR CAD</i> | DIV ENGINEER |
| | | PROJECT NO. <i>37642</i> | SECTION <i>####</i> | |
| | | FHWA PROJECT NUMBER <i>X-CM-XXXX-(PDX)</i> | | |
| NO. | DATE | DESCRIPTION | APPD. | |
| | | REVISION | | |

APPROVALS:

DIVISION ENGINEER _____ REG. PROF. ENGR. NO. 51538PE

CITY ENGINEER _____ REG. PROF. ENGR. NO. 51538PE



CITY OF PORTLAND
OFFICE OF
TRANSPORTATION

SAM ADAMS
STEVE TOWNSEN, P.E.

COMMISSIONER
CITY ENGINEER

Temporary Construction Easement
722-738 E. BURNSIDE ST.

NE 3RD AVE - NE 14TH AVE (PORTLAND) SEC
E BURNSIDE - NE COUCH COUPLET

SHEET NO.
1



Harper Houf Peterson Righellis Inc.
ENGINEERS • PLANNERS
LANDSCAPE ARCHITECTS • SURVEYORS
205 SE Spokane Street, Suite 200, Portland, OR 97202
phone: 503.221.1131 www.hhpr.com fax: 503.221.1171

EXHIBIT 8

E. BURNSIDE ST.

S.E. 9TH AVE.

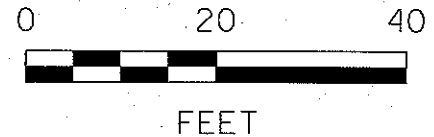
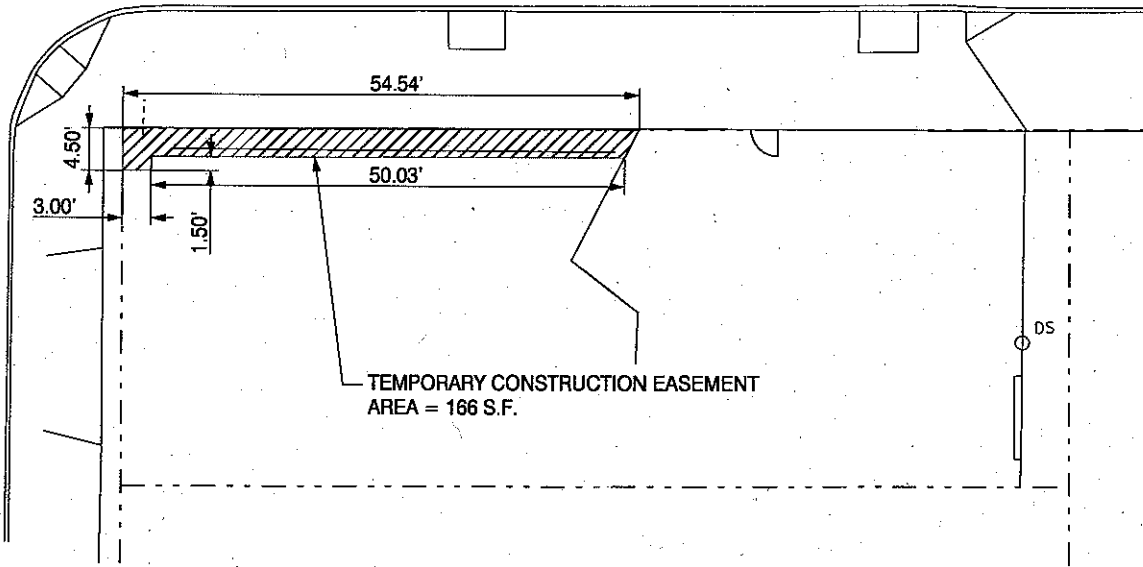

ROW FILE NO. 15
TAX LOT 1N1E35CD 1900

| NO. | DATE | DESCRIPTION | APPD. | CHECKED BY | DESIGNED BY | DATE APPROVED |
|----------|------|-------------|-------|-------------|---------------------|---------------|
| | | | | ADP | HHPR TEAM | |
| | | | | | HHPR CAD | |
| | | | | | ### | |
| REVISION | | | | PROJECT NO. | FHWA PROJECT NUMBER | |
| | | | | 37642 | X-CM-XXXX-(PDX) | |



Harper Houf Peterson Righellis Inc.
ENGINEERS • PLANNERS
LANDSCAPE ARCHITECTS • SURVEYORS
205 SE Spokane Street, Suite 200, Portland, OR 97202
phone: 503.221.1131 www.hhpr.com fax: 503.221.1171

APPROVALS:

DIVISION ENGINEER _____ REG. PROF. ENGR. NO. 51538PE

CITY ENGINEER _____ REG. PROF. ENGR. NO. 51538PE

CITY OF PORTLAND
OFFICE OF
TRANSPORTATION

SAM ADAMS
STEVE TOWNSEN, P.E.

COMMISSIONER
CITY ENGINEER

Temporary Construction Easement
910 E. BURNSIDE ST.

NE 3RD AVE - NE 14TH AVE (PORTLAND) SEC

E BURNSIDE - NE COUCH COUPLER

SHEET NO. **1**

EXHIBIT 9

E. BURNSIDE ST.

S.E. 10TH AVE.

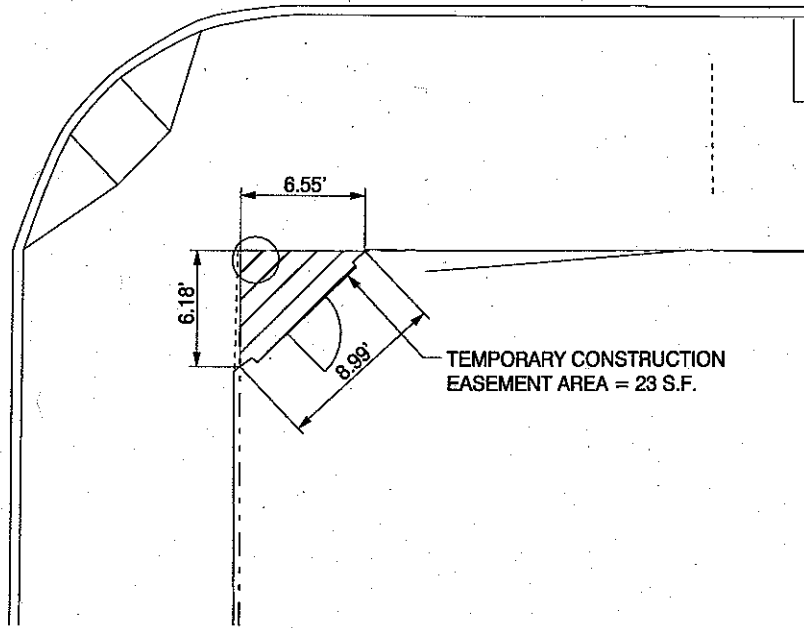

TEMPORARY CONSTRUCTION
EASEMENT AREA = 23 S.F.

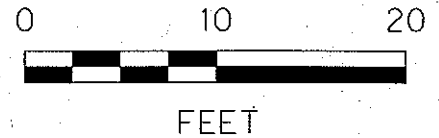

ROW FILE NO. 17
TAX LOT 1N1E35CD 1400

| | | | | |
|----------------------------|--|---|---------------------------------|---------------|
| | | CHECKED BY <i>ADP</i> | DESIGNED BY <i>HHPR TEAM</i> | DATE APPROVED |
| | | | CAD BY <i>HHPR CAD</i> | DIV ENGINEER |
| | | PROJECT NO. 37642 | 1/4 SECTION #### | |
| NO. DATE DESCRIPTION APPD. | | FHWA PROJECT NUMBER <i>X-CM-XXXX-(PDX)</i> | | |
| REVISION | | | | |



**Harper
Houf Peterson
Righellis Inc.**
ENGINEERS • PLANNERS
LANDSCAPE ARCHITECTS • SURVEYORS
205 SE Spokane Street, Suite 200, Portland, OR 97202
phone: 503.221.1131 www.hhpr.com fax: 503.221.1171

APPROVALS:

DIVISION ENGINEER _____ REG. PROF. ENGR. NO. 51538PE

CITY ENGINEER _____ REG. PROF. ENGR. NO. 51538PE

**CITY OF
PORTLAND
OFFICE OF
TRANSPORTATION**

SAM ADAMS
STEVE TOWNSEN, P.E.

COMMISSIONER
CITY ENGINEER

**Temporary Construction Easement
1000 E. BURNSIDE ST.**

NE 3RD AVE - NE 14TH AVE (PORTLAND) SEC

E BURNSIDE - NE COUCH COUPLET

SHEET NO. **1**

EXHIBIT 10

E. BURNSIDE ST.

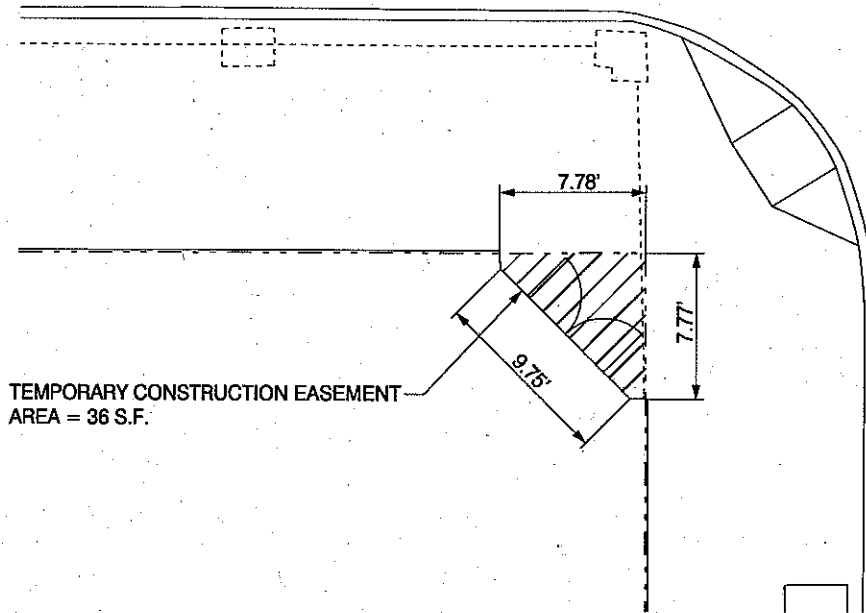

S.E. 11TH AVE.

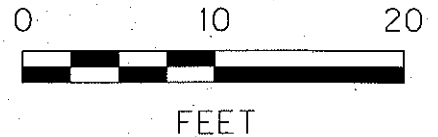

ROW FILE NO. 18
TAX LOT 1N1E35CD 1000

| | | | | |
|-----|------|---|---------------------------------|---------------|
| | | CHECKED BY <i>RDJ</i> | DESIGNED BY <i>HHPR TEAM</i> | DATE APPROVED |
| | | | CAD BY <i>HHPR CAD</i> | DIV ENGINEER |
| | | PROJECT NO. 37642 | 1/4 SECTION #### | |
| | | FNWA PROJECT NUMBER <i>X-CM-XXXX-(PDX)</i> | | |
| NO. | DATE | DESCRIPTION | APPD. | |
| | | REVISION | | |



Harper Houf Peterson Righellis Inc.
ENGINEERS • PLANNERS
LANDSCAPE ARCHITECTS • SURVEYORS
205 SE Spokane Street, Suite 200, Portland, OR 97202
phone: 503.221.1131 www.hhpr.com fax: 503.221.1171

APPROVALS:

DIVISION ENGINEER _____ REG. PROF. ENGR. NO. 51538PE

CITY ENGINEER _____ REG. PROF. ENGR. NO. 51538PE

CITY OF PORTLAND
OFFICE OF TRANSPORTATION

SAM ADAMS
STEVE TOWNSEN, P.E.

COMMISSIONER
CITY ENGINEER

Temporary Construction Easement
1040 E. BURNSIDE ST.

NE 3RD AVE - NE 14TH AVE (PORTLAND) SEC
E BURNSIDE - NE COUCH COUPLET

SHEET NO. **1**

EXHIBIT 11

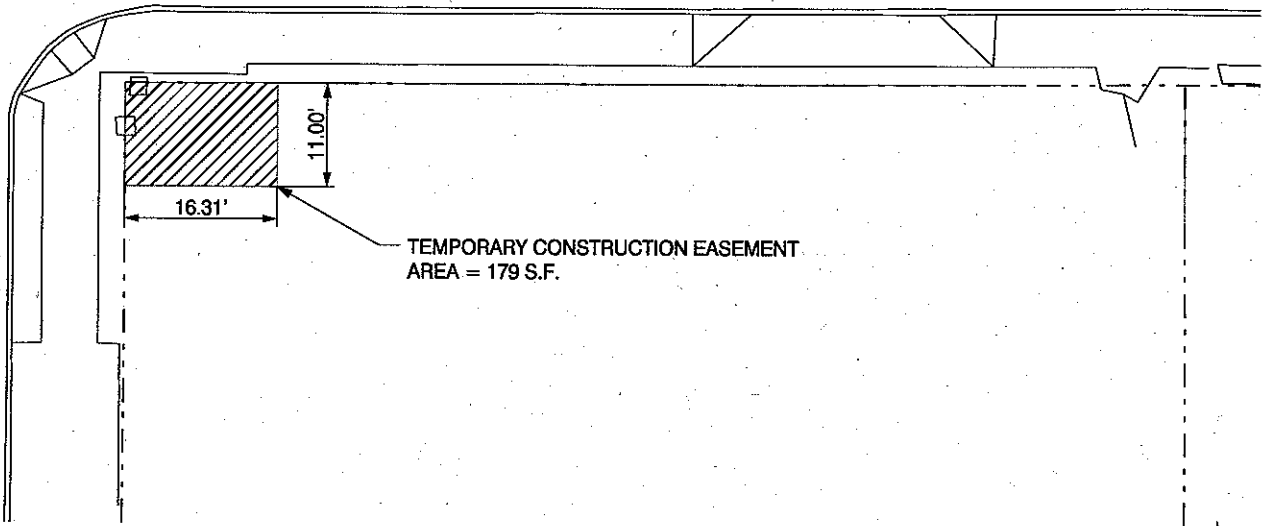

E. BURNSIDE ST.

S.E. 11TH AVE.

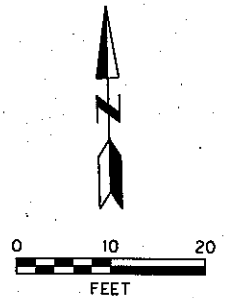

ROW FILE NO. 19
TAX LOT 1N1E35CD 800



| | | | | |
|----------------------------|--|--|---------------------------------|---------------|
| | | CHECKED BY <i>ADP</i> | DESIGNED BY <i>HHPR TEAM</i> | DATE APPROVED |
| | | | CAD BY <i>HHPR CAD</i> | DIV ENGINEER |
| | | PROJECT NO. <i>37642</i> | SECTION <i>####</i> | |
| NO. DATE DESCRIPTION APPD. | | FHWA PROJECT NUMBER <i>X-CM-XXXX-(PDX)</i> | | |
| REVISION | |   Harper Houf Peterson Righellis Inc. ENGINEERS • PLANNERS LANDSCAPE ARCHITECTS • SURVEYORS 205 SE Spokane Street, Suite 200, Portland, OR 97202 phone: 503.221.1131 www.hhpr.com fax: 503.221.1171 | | |

APPROVALS:

| | |
|-------------------|------------------------------|
| DIVISION ENGINEER | REG. PROF. ENGR. NO. 51538PE |
| CITY ENGINEER | REG. PROF. ENGR. NO. 51538PE |



CITY OF PORTLAND
OFFICE OF
TRANSPORTATION

SAM ADAMS
STEVE TOWNSEN, P.E.

COMMISSIONER
CITY ENGINEER

| | | |
|---|--|-----------|
| NE 3RD AVE - NE 14TH AVE (PORTLAND) SEC | | SHEET NO. |
| E BURNSIDE - NE COUCH COUPLET | | |

EXHIBIT 12

E. BURNSIDE ST.

N.E. SANDY BLVD.

S.E. 12TH AVE.

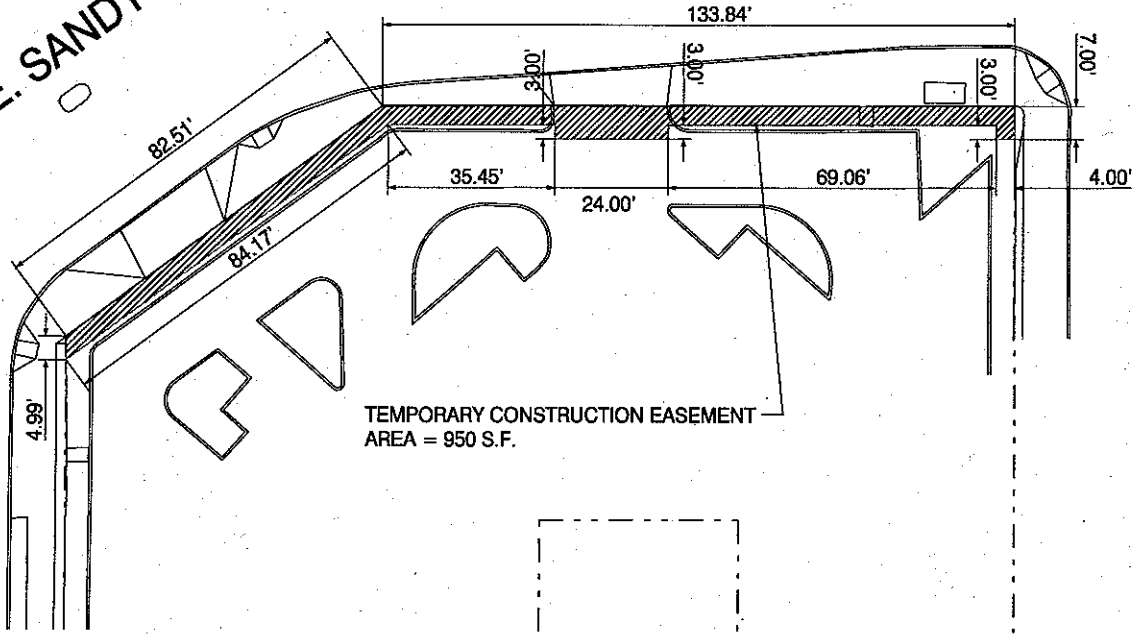

TEMPORARY CONSTRUCTION EASEMENT
AREA = 950 S.F.

ROW FILE NO. 21
TAX LOT 1N1E35CD 400



| | | | | |
|---------------------|--|-------------|-------------|---------------|
| NO. | | DATE | DESCRIPTION | APPD. |
| REVISION | | | | |
| CHECKED BY | | DESIGNED BY | | DATE APPROVED |
| RDP | | HHPR TEAM | | |
| | | CAD BY | | DIV ENGINEER |
| | | HHPR CAD | | |
| PROJECT NO. | | 1/2 SECTION | | |
| 37842 | | #### | | |
| FHWA PROJECT NUMBER | | | | |
| X-CM-XXXX-(PDX) | | | | |



Harper, Houf Peterson Righellis Inc.

ENGINEERS • PLANNERS
LANDSCAPE ARCHITECTS • SURVEYORS
205 SE Spokane Street, Suite 200, Portland, OR 97202
phone: 503.221.1131 www.hhpr.com fax: 503.221.1171

APPROVALS:

DIVISION ENGINEER _____ REG. PROF. ENGR. NO. 51536PE

CITY ENGINEER _____ REG. PROF. ENGR. NO. 51536PE

CITY OF PORTLAND
OFFICE OF
TRANSPORTATION

SAM ADAMS
STEVE TOWNSEN, P.E.

COMMISSIONER
CITY ENGINEER

Temporary Construction Easement
1302 S.E. ANKENY ST.

NE 3RD AVE - NE 14TH AVE (PORTLAND) SEC

E BURNSIDE - NE COUCH COUPLET

SHEET NO. **1**

EXHIBIT 13

E. BURNSIDE ST.

S.E. 13TH AVE.

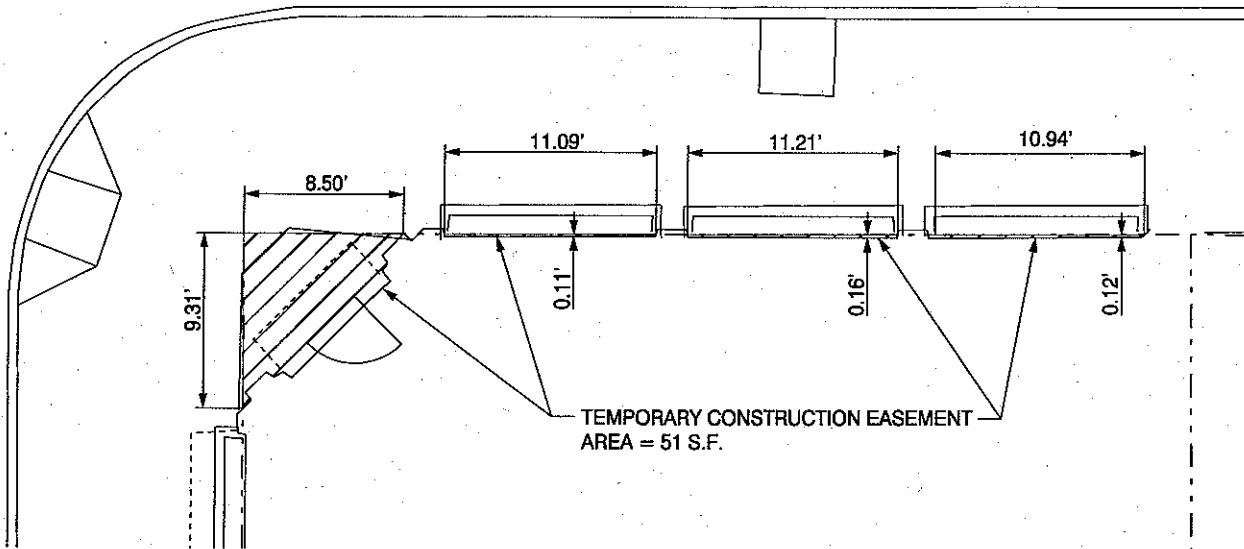

TEMPORARY CONSTRUCTION EASEMENT
AREA = 51 S.F.



ROW FILE NO. 22
TAX LOT 1N1E35CD 300

| | | | | |
|---------------------|--|-------------|-------------|---------------|
| NO. | | DATE | DESCRIPTION | APPD. |
| REVISION | | | | |
| CHECKED BY | | DESIGNED BY | | DATE APPROVED |
| RDP | | HHPR TEAM | | |
| | | CAD BY | | DIV ENGINEER |
| | | HHPR CAD | | |
| PROJECT NO. | | 1/2 SECTION | | |
| 37642 | | #### | | |
| FHWA PROJECT NUMBER | | | | |
| X-CM-XXXX-(PDX) | | | | |



Harper Houf Peterson Righellis Inc.
ENGINEERS • PLANNERS
LANDSCAPE ARCHITECTS • SURVEYORS
205 SE Spokane Street, Suite 200, Portland, OR 97202
phone: 503.221.1131 www.hhpr.com fax: 503.221.1171

APPROVALS:

DIVISION ENGINEER _____ REG. PROF. ENGR. NO. 51538PE

CITY ENGINEER _____ REG. PROF. ENGR. NO. 51538PE

CITY OF PORTLAND
OFFICE OF
TRANSPORTATION

SAM ADAMS
STEVE TOWNSEN, P.E.

COMMISSIONER
CITY ENGINEER

Temporary Construction Easement
1300 E. BURNSIDE ST.

NE 3RD AVE - NE 14TH AVE (PORTLAND) SEC
E BURNSIDE - NE COUCH COUPLET

SHEET NO. **1**

E. BURNSIDE ST.

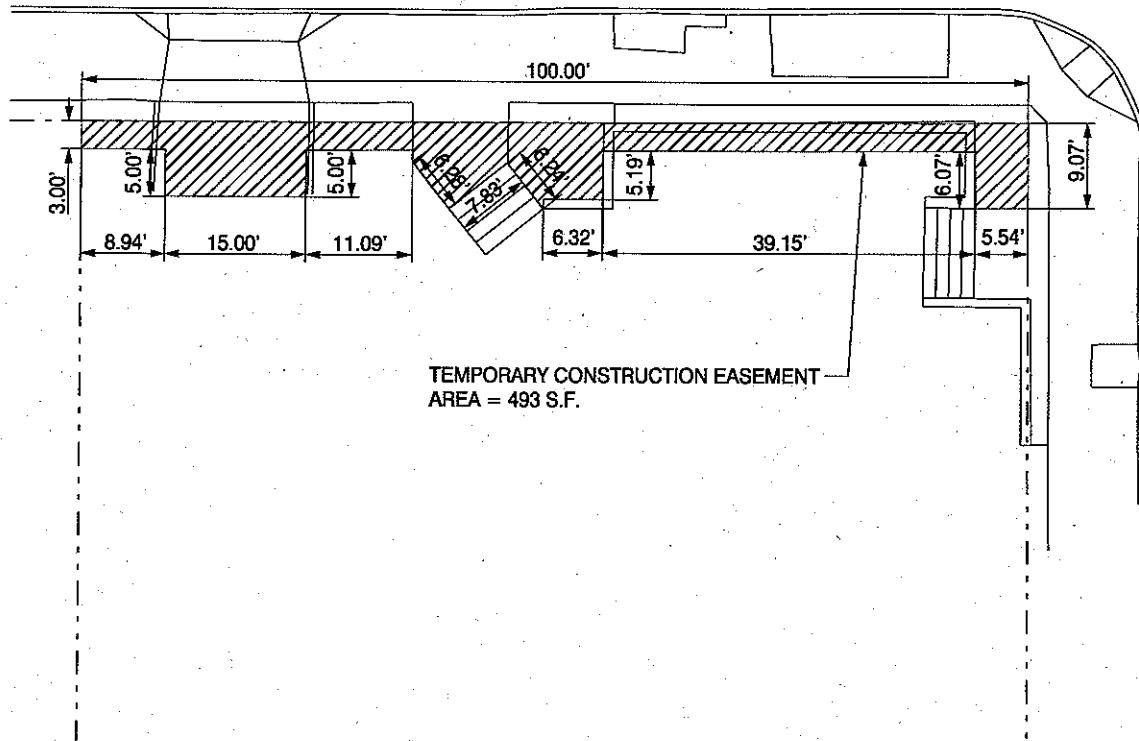



TEMPORARY CONSTRUCTION EASEMENT
AREA = 493 S.F.

S.E. 14TH AVE.

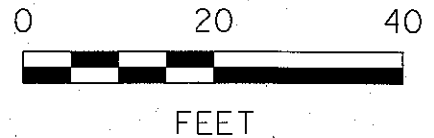
ROW FILE NO. 24
TAX LOT 1N1E35CD 100



| | | | | | | | |
|-----|--|----------------------|--|---|--|--|--|
| | | CHECKED BY RDP | | DESIGNED BY HHPR TEAM | | DATE APPROVED | |
| | | | | CAD BY HHPR CAD | | DIV ENGINEER | |
| | | PROJECT NO. 37642 | | SECTION #### | | | |
| NO. | | DATE | | DESCRIPTION | | APPD. | |
| | | | | REVISION | | | |
| | | | | FHWA PROJECT NUMBER X-CM-XXXX-(PDX) | | | |
| | | | |  | |  Harper Houf Peterson Righellis Inc. ENGINEERS • PLANNERS LANDSCAPE ARCHITECTS • SURVEYORS 205 SE Spokane Street, Suite 200, Portland, OR 97202 phone: 503.221.1131 www.hhpr.com fax: 503.221.1171 | |

APPROVALS:

| | |
|-------------------|------------------------------|
| DIVISION ENGINEER | REG. PROF. ENGR. NO. 51538PE |
| CITY ENGINEER | REG. PROF. ENGR. NO. 51538PE |



**CITY OF
PORTLAND
OFFICE OF
TRANSPORTATION**

SAM ADAMS
STEVE TOWNSEN, P.E.

COMMISSIONER
CITY ENGINEER

**Temporary Construction Easement
1336 E. BURNSIDE ST.**

NE 3RD AVE - NE 14TH AVE (PORTLAND) SEC
E BURNSIDE - NE COUCH COUPLET

SHEET NO. **1**

EXHIBIT 15

E. BURNSIDE ST.

S.E. 14TH AVE.

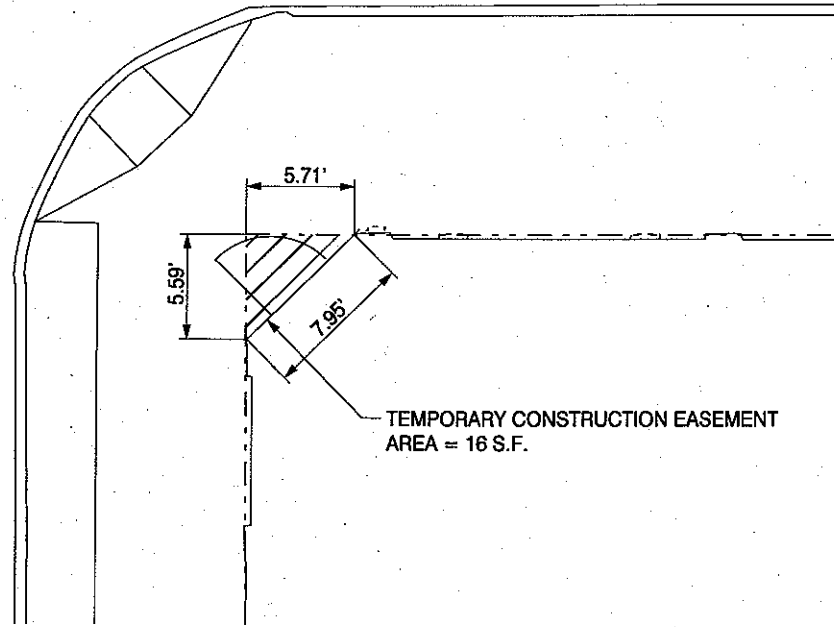

TEMPORARY CONSTRUCTION EASEMENT
AREA = 16 S.F.

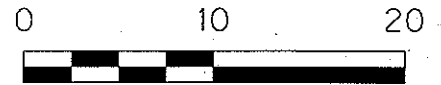

FEET

ROW FILE NO. 25
TAX LOT 1N1E35DC 1800

| | | | | | |
|---|------|---------------------------------|-------|---------------|--|
| CHECKED BY <i>RDP</i> | | DESIGNED BY <i>HHPR TEAM</i> | | DATE APPROVED | |
| PROJECT NO. 37642 | | CAD BY <i>HHPR CAD</i> | | DIV ENGINEER | |
| FWHA PROJECT NUMBER <i>X-CM-XXXX-(PDX)</i> | | | | | |
| NO. | DATE | DESCRIPTION | APPD. | | |
| REVISION | | | | | |



HHPR Harper Houf Peterson Righellis Inc.
ENGINEERS • PLANNERS
LANDSCAPE ARCHITECTS • SURVEYORS
205 SE Spokane Street, Suite 200, Portland, OR 97202
phone: 503.221.1131 www.hhpr.com fax: 503.221.1171

APPROVALS:

| | |
|-------------------|------------------------------|
| DIVISION ENGINEER | REG. PROF. ENGR. NO. 51538PE |
| CITY ENGINEER | REG. PROF. ENGR. NO. 51538PE |

CITY OF PORTLAND
OFFICE OF TRANSPORTATION

SAM ADAMS
STEVE TOWNSEN, P.E.

COMMISSIONER
CITY ENGINEER

Temporary Construction Easement
1400-1418 E. BURNSIDE ST.

NE 3RD AVE - NE 14TH AVE (PORTLAND) SEC
E BURNSIDE - NE COUCH COUPLER

SHEET NO. **1**

EXHIBIT 16

N.E. ML KING JR. BLVD.

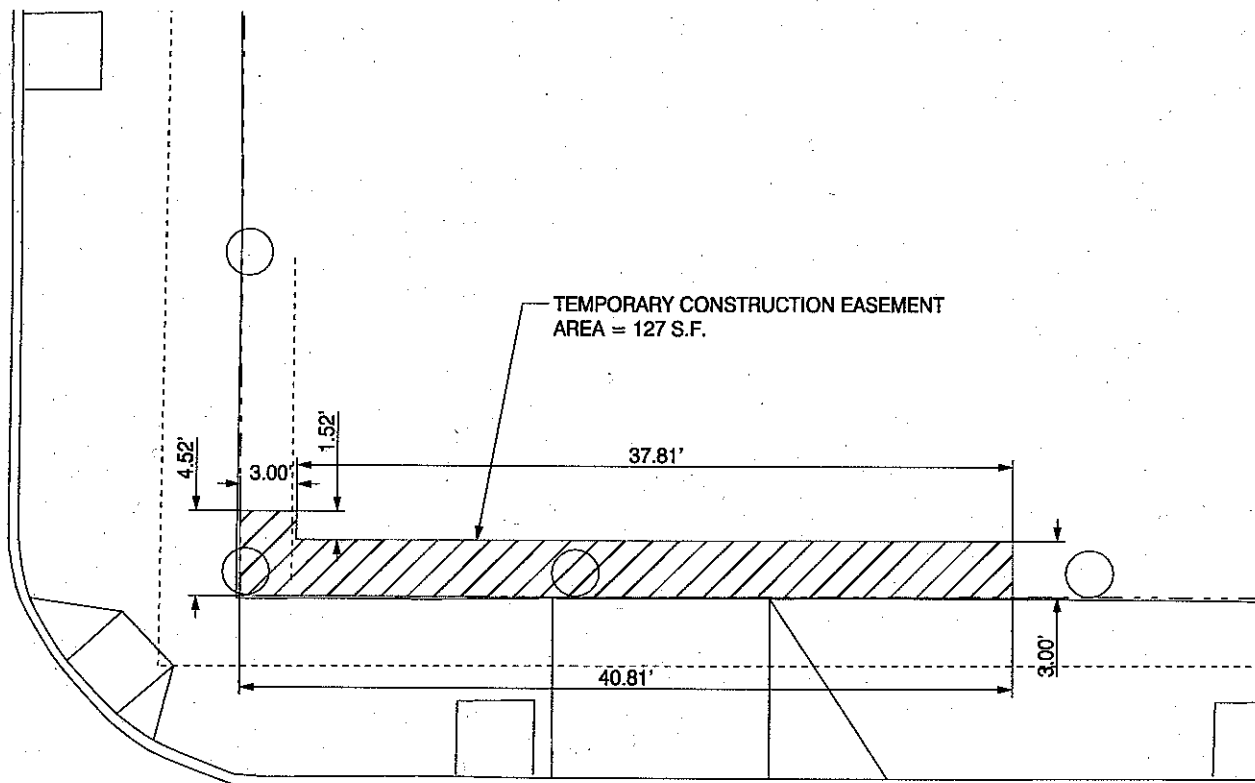

E. BURNSIDE ST.

ROW FILE NO. 33
TAX LOT 1N1E35CB 8900

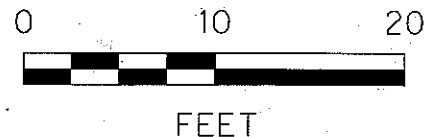

| | | | | |
|----------|------|-----------------------------|---------------------------------|---|
| | | CHECKED BY <i>RDP</i> | DESIGNED BY <i>HHPR TEAM</i> | DATE APPROVED |
| | | | CAD BY <i>HHPR CAD</i> | DIV ENGINEER |
| | | PROJECT NO. <i>37642</i> | %SECTION <i>###</i> | |
| NO. | DATE | DESCRIPTION | APPD. | FHWA PROJECT NUMBER <i>X-CM-XXXX-(PDX)</i> |
| REVISION | | | | |



Harper Houf Peterson Righellis Inc.
ENGINEERS • PLANNERS
LANDSCAPE ARCHITECTS • SURVEYORS
205 SE Spokane Street, Suite 200, Portland, OR 97202
phone: 503.221.1131 www.hhpr.com fax: 503.221.1171

APPROVALS:

| | |
|-------------------|------------------------------|
| DIVISION ENGINEER | REG. PROF. ENGR. NO. 51538PE |
| CITY ENGINEER | REG. PROF. ENGR. NO. 51538PE |

CITY OF PORTLAND
OFFICE OF TRANSPORTATION

SAM ADAMS
STEVE TOWNSEN, P.E.

COMMISSIONER
CITY ENGINEER

Temporary Construction Easement
419 E. BURNSIDE ST.

NE 3RD AVE - NE 14TH AVE (PORTLAND) SEC
E BURNSIDE - NE COUCH COUPLE

SHEET NO. **1**

EXHIBIT 17

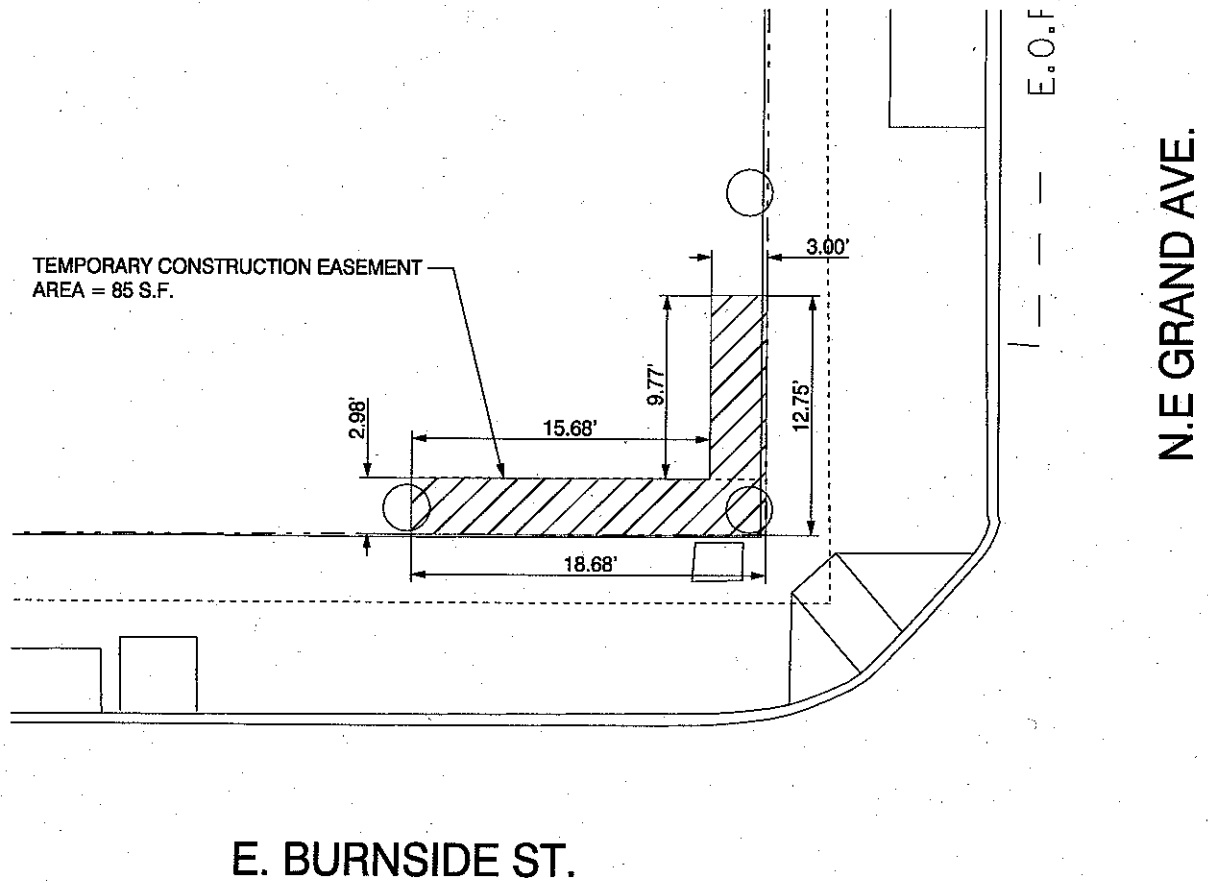

ROW FILE NO. 34
TAX LOT 1N1E35CB 8700

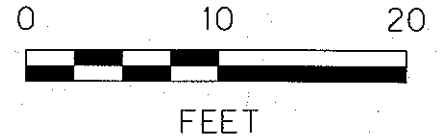



| | | | | | | |
|---|--|--|--------------------------|--|---|--|
| | | CHECKED BY RDP | DESIGNED BY HHPR TEAM | DATE APPROVED |  |  Harper Houf Peterson Righellis Inc. <small>ENGINEERS • PLANNERS LANDSCAPE ARCHITECTS • SURVEYORS 205 SE Spokane Street, Suite 200, Portland, OR 97202 phone: 503.221.1131 www.hhpr.com fax: 503.221.1171</small> |
| | | | CAD BY HHPR CAD | DIV ENGINEER | | |
| | | PROJECT NO. 37642 | SECTION ### | | | |
| | | FHWA PROJECT NUMBER X-CM-XXXX-(PDX) | | | | |
| APPROVALS: DIVISION ENGINEER _____ REG. PROF. ENGR. NO. 51538PE CITY ENGINEER _____ REG. PROF. ENGR. NO. 51538PE | |  CITY OF PORTLAND OFFICE OF TRANSPORTATION SAM ADAMS STEVE TOWNSEN, P.E. | | Temporary Construction Easement 419 E. BURNSIDE ST. NE 3RD AVE - NE 14TH AVE (PORTLAND) SEC E BURNSIDE - NE COUCH COUPLET | | SHEET NO. 1 |

EXHIBIT 18

N.E. GRAND AVE.

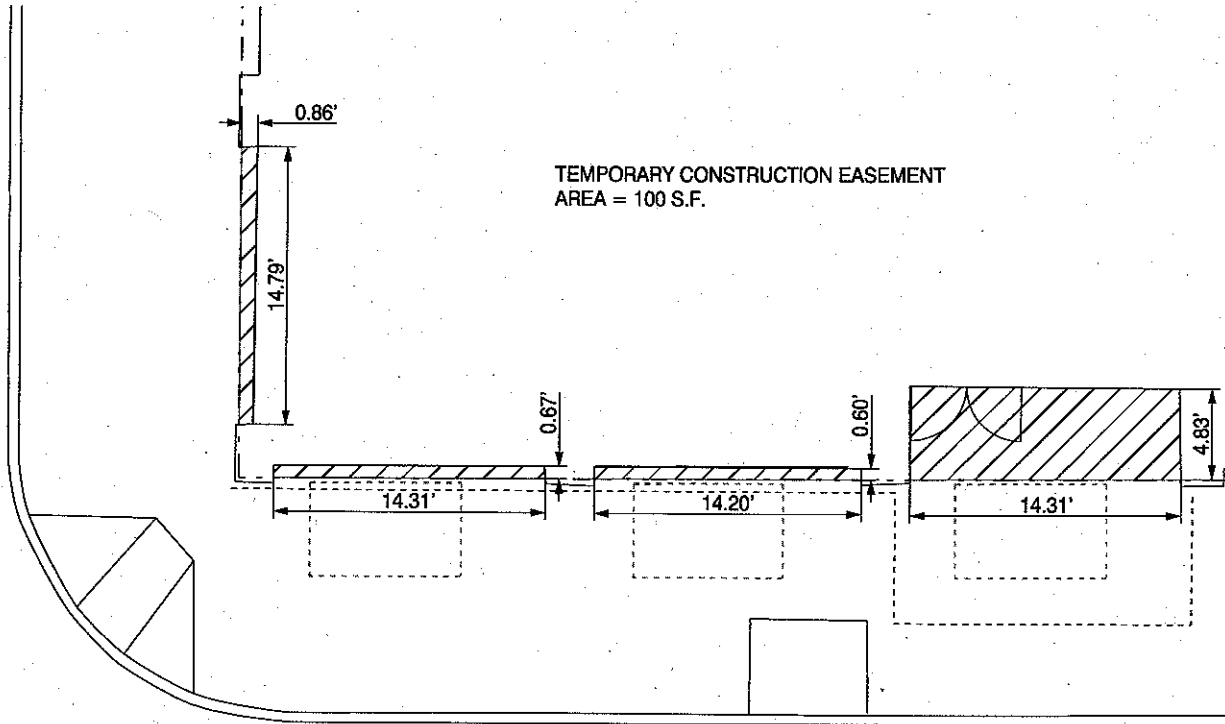

TEMPORARY CONSTRUCTION EASEMENT
AREA = 100 S.F.

E. BURNSIDE ST.



ROW FILE NO. 36
TAX LOT 1N1E35CB 8300

| | | | | | | |
|-----|------|-------------|-------|--|--------------------------|---------------|
| | | | | CHECKED BY RDP | DESIGNED BY HHPR TEAM | DATE APPROVED |
| | | | | | CAD BY HHPR CAD | DIV ENGINEER |
| | | | | PROJECT NO. 37642 | SECTION #### | |
| | | | | FHWA PROJECT NUMBER X-CM-XXXX-(PDX) | | |
| NO. | DATE | DESCRIPTION | APPD. | REVISION | | |



Harper Houf Peterson Righellis Inc.
ENGINEERS • PLANNERS
LANDSCAPE ARCHITECTS • SURVEYORS
205 SE Spokane Street, Suite 200, Portland, OR 97202
phone: 503.221.1131 www.hhpr.com fax: 503.221.1171

APPROVALS:

| | |
|-------------------|------------------------------|
| DIVISION ENGINEER | REG. PROF. ENGR. NO. 51538PE |
| CITY ENGINEER | REG. PROF. ENGR. NO. 51538PE |

CITY OF PORTLAND
OFFICE OF
TRANSPORTATION

SAM ADAMS
STEVE TOWNSEN, P.E.

COMMISSIONER
CITY ENGINEER

Temporary Construction Easement
515 E. BURNSIDE ST.

NE 3RD AVE - NE 14TH AVE (PORTLAND) SEC
E BURNSIDE - NE COUCH COUPLET

SHEET NO. **1**

EXHIBIT 19

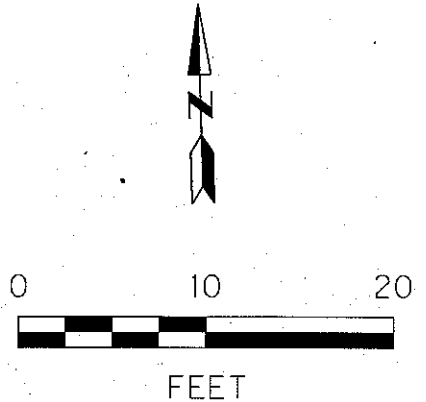
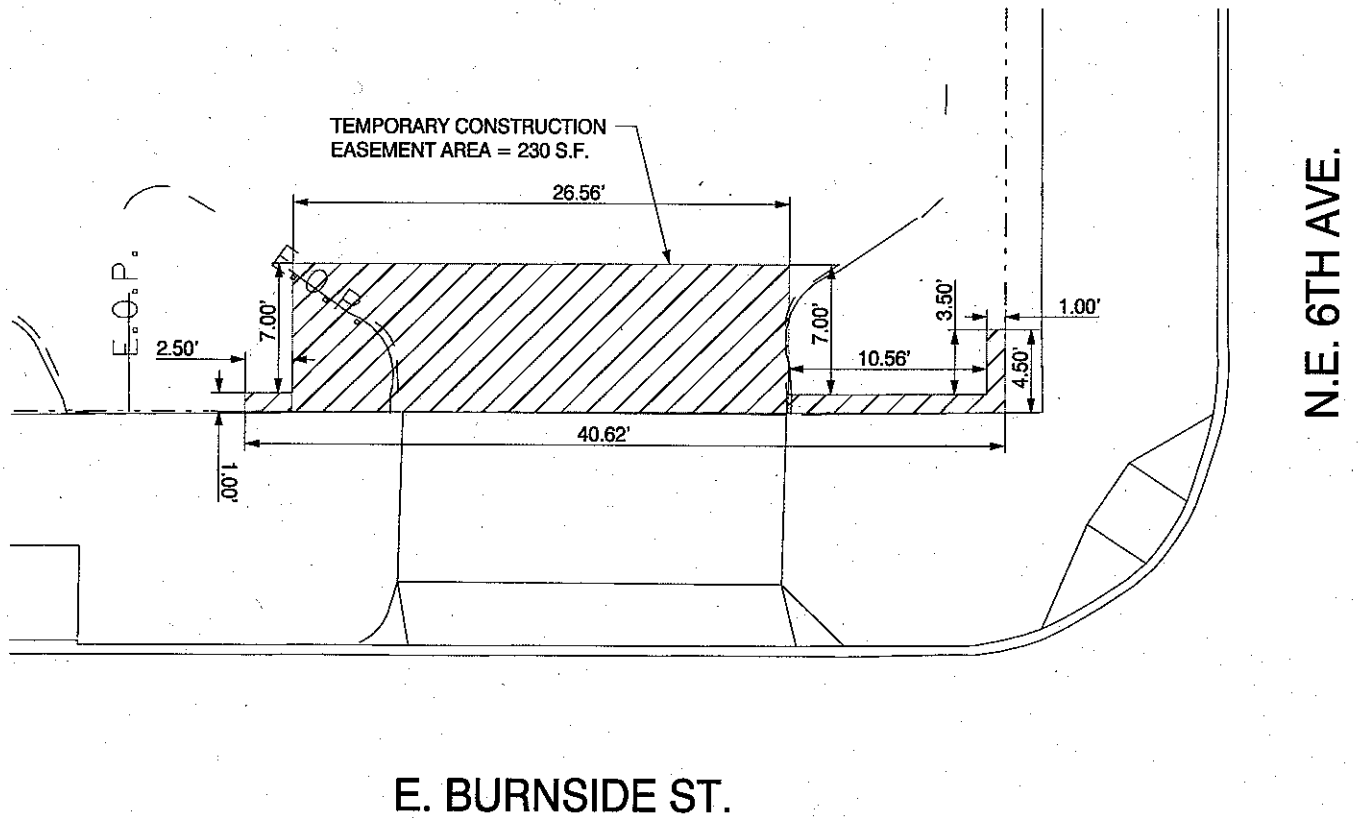

ROW FILE NO. 37
TAX LOT 1N1E35CB 8200



| | | | | |
|---|------|--|---------------------------------|-----------------------|
| | | CHECKED BY <i>RDP</i> | DESIGNED BY <i>HHPR TEAM</i> | DATE APPROVED |
| | | | CAD BY <i>HHPR CAD</i> | DIY ENGINEER |
| | | PROJECT NO. 37642 | SECTION #### | |
| | | FHWA PROJECT NUMBER X-CM-XXXX-(PDX) | | |
| NO. | DATE | DESCRIPTION | REVISION | |
| | | | | |
| APPROVALS: | |  Harper Houf Peterson Righellis Inc. ENGINEERS • PLANNERS LANDSCAPE ARCHITECTS • SURVEYORS 205 SE Spokane Street, Suite 200, Portland, OR 97202 phone: 503.221.1131 www.hhpr.com fax: 503.221.1171 | | |
| DIVISION ENGINEER _____ REG. PROF. ENGR. NO. 51538PE CITY ENGINEER _____ REG. PROF. ENGR. NO. 51538PE | | | | |
|  CITY OF PORTLAND OFFICE OF TRANSPORTATION SAM ADAMS STEVE TOWNSEN, P.E. | | Temporary Construction Easement 515 E. BURNSIDE ST. NE 3RD AVE - NE 14TH AVE (PORTLAND) SEC E BURNSIDE - NE COUCH COUPLET | | |
| | | COMMISSIONER CITY ENGINEER | | SHEET NO. 1 |

EXHIBIT 20

N.E. 6TH AVE.



E. BURNSIDE ST.

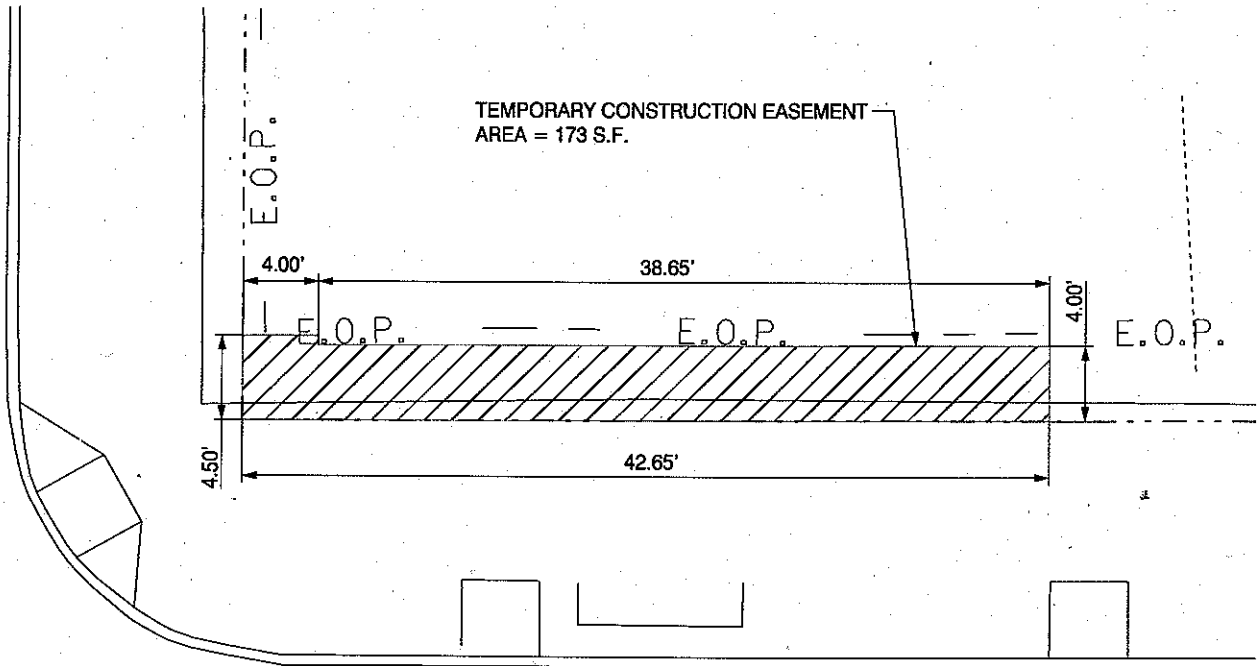

ROW FILE NO. 38
TAX LOT 1N1E35CB 7800

| | | | | |
|---------------------|--|-------------|-------------|---------------|
| NO. | | DATE | DESCRIPTION | APPD. |
| REVISION | | | | |
| CHECKED BY | | DESIGNED BY | | DATE APPROVED |
| RDP | | HHPR TEAM | | |
| PROJECT NO. | | CAD BY | | DIV ENGINEER |
| 37642 | | HHPR CAD | | |
| | | SECTION | | |
| | | #### | | |
| FWMA PROJECT NUMBER | | | | |
| X-CM-XXXX-(PDX) | | | | |



Harper Houf Peterson Righellis Inc.
ENGINEERS • PLANNERS
LANDSCAPE ARCHITECTS • SURVEYORS
205 SE Spokane Street, Suite 200, Portland, OR 97202
phone: 503.221.1131 www.hhpr.com fax: 503.221.1171

APPROVALS:

| | |
|-------------------|------------------------------|
| DIVISION ENGINEER | REG. PROF. ENGR. NO. 51538PE |
| CITY ENGINEER | REG. PROF. ENGR. NO. 51538PE |

CITY OF PORTLAND
OFFICE OF
TRANSPORTATION

SAM ADAMS
STEVE TOWNSEN, P.E.

COMMISSIONER
CITY ENGINEER

Temporary Construction Easement
611 E. BURNSIDE ST.

NE 3RD AVE - NE 14TH AVE (PORTLAND) SEC
E BURNSIDE - NE COUCH COUPLET

SHEET NO. **1**

EXHIBIT 21

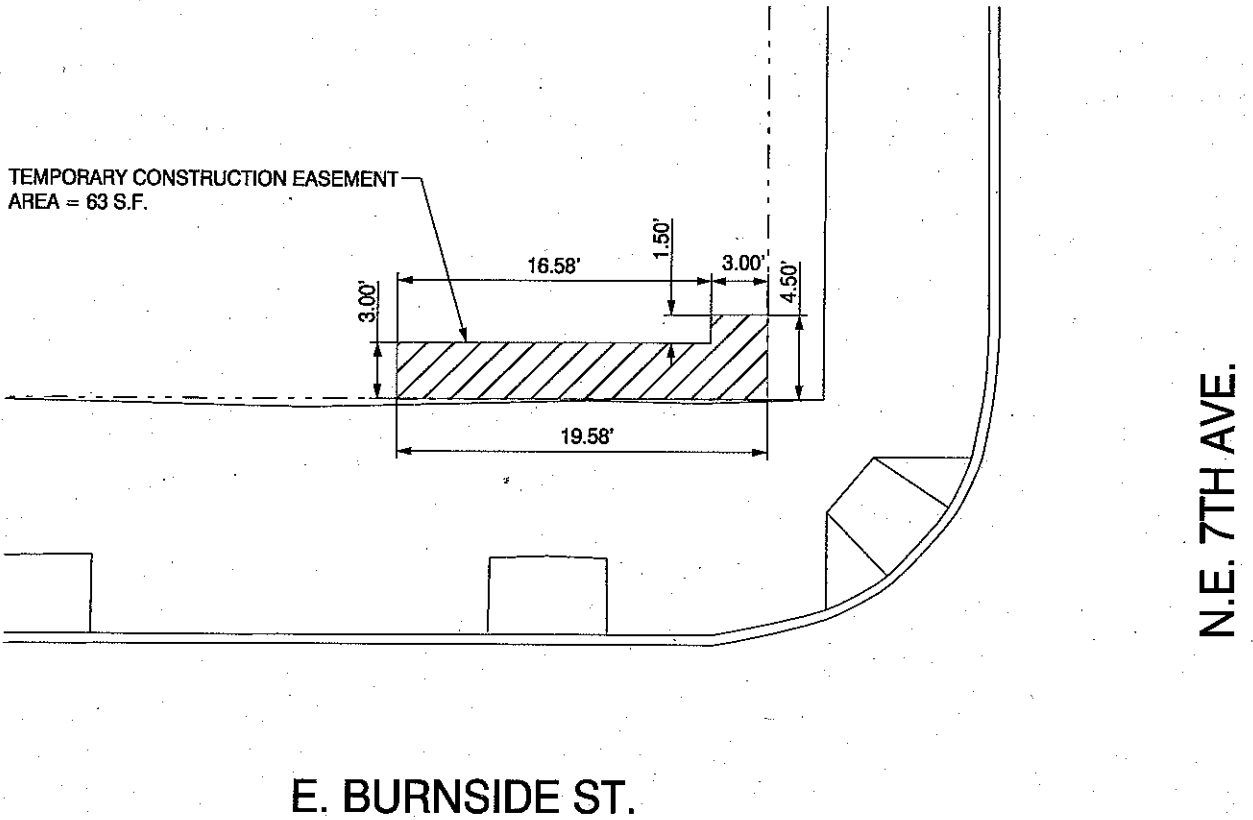

ROW FILE NO. 39
TAX LOT 1N1E35CB 7700

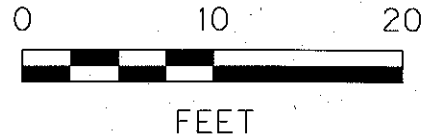

| | | | | |
|----------|------|-----------------------------|---------------------------------|--|
| | | CHECKED BY <i>RDP</i> | DESIGNED BY <i>HHPR TEAM</i> | DATE APPROVED |
| | | | CAD BY <i>HHPR CAD</i> | DEV ENGINEER |
| | | PROJECT NO. <i>37642</i> | 1/4 SECTION <i>####</i> | |
| NO. | DATE | DESCRIPTION | APPD. | FHW PROJECT NUMBER <i>X-CM-XXXX-(PDX)</i> |
| REVISION | | | | |



Harper Houf Peterson Righellis Inc.
ENGINEERS • PLANNERS
LANDSCAPE ARCHITECTS • SURVEYORS
205 SE Spokane Street, Suite 200, Portland, OR 97202
phone: 503.221.1131 www.hhpr.com fax: 503.221.1171

APPROVALS:

DIVISION ENGINEER REG. PROF. ENGR. NO. 51538PE

CITY ENGINEER REG. PROF. ENGR. NO. 51538PE

CITY OF PORTLAND
OFFICE OF
TRANSPORTATION

SAM ADAMS
STEVE TOWNSEN, P.E.

COMMISSIONER
CITY ENGINEER

Temporary Construction Easement
635 E. BURNSIDE ST.

NE 3RD AVE - NE 14TH AVE (PORTLAND) SEC

E BURNSIDE - NE COUCH COUPLET

SHEET NO. **1**

EXHIBIT 22

N.E. 8TH AVE.

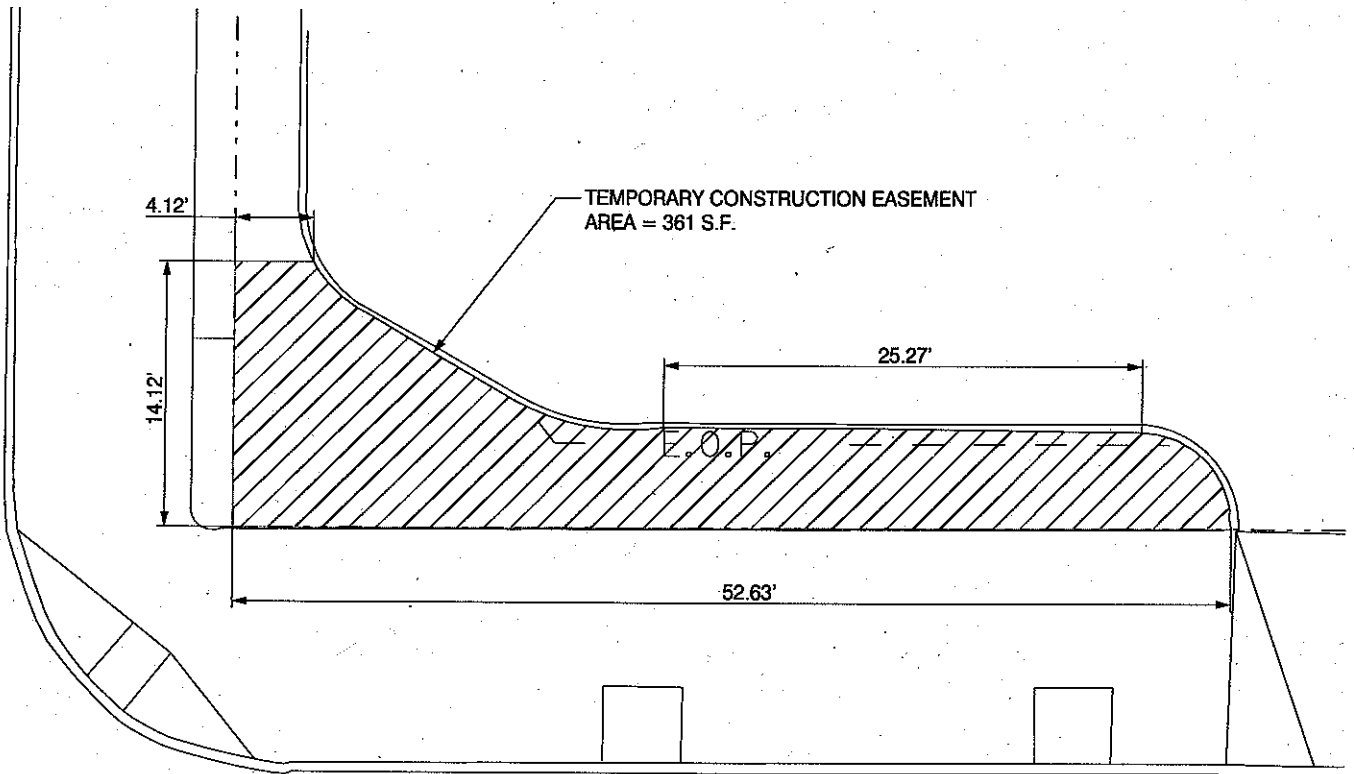

E. BURNSIDE ST.

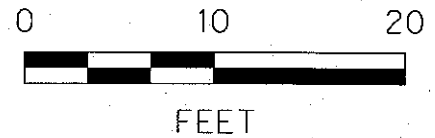

ROW FILE NO. 40
TAX LOT 1N1E35CB 7300

| | | | | |
|-----|------|----------------------|--------------------------|--|
| | | CHECKED BY RDP | DESIGNED BY HHPR TEAM | DATE APPROVED |
| | | | CAD BY HHPR CAD | DIV ENGINEER |
| | | PROJECT NO. 37642 | 1/2 SECTION #### | |
| NO. | DATE | DESCRIPTION | APPD. | FHWA PROJECT NUMBER X-CM-XXXX-(PDX) |
| | | REVISION | | |



Harper Houf Peterson Righellis Inc.
ENGINEERS • PLANNERS
LANDSCAPE ARCHITECTS • SURVEYORS
205 SE Spokane Street, Suite 200, Portland, OR 97202
phone: 503.221.1131 www.hhpr.com fax: 503.221.1171

APPROVALS:

DIVISION ENGINEER _____ REG. PROF. ENGR. NO. 51538PE

CITY ENGINEER _____ REG. PROF. ENGR. NO. 51538PE

CITY OF PORTLAND
OFFICE OF TRANSPORTATION

SAM ADAMS
STEVE TOWNSEN, P.E.

COMMISSIONER
CITY ENGINEER

Temporary Construction Easement
701 E. BURNSIDE ST.

NE 3RD AVE - NE 14TH AVE (PORTLAND) SEC
E BURNSIDE - NE COUCH COUPLET

SHEET NO. **1**

EXHIBIT 23

N.E. 8TH AVE.

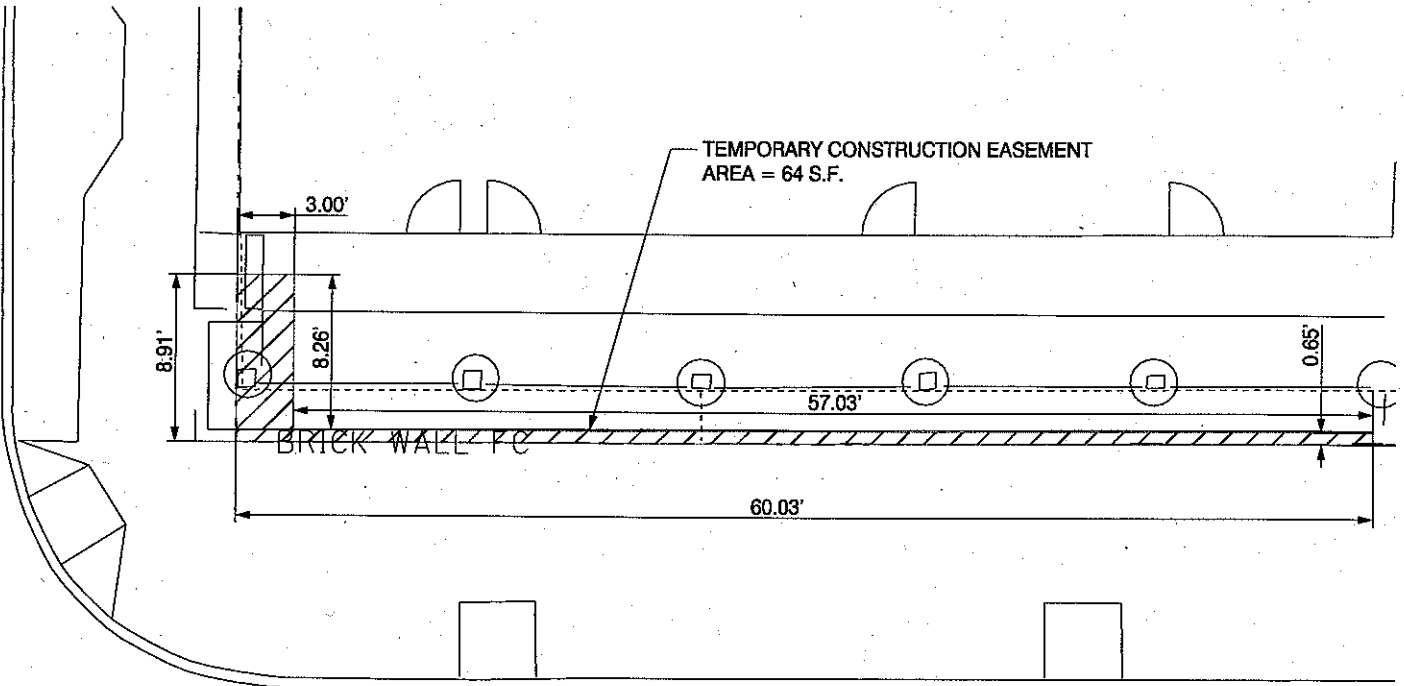

E. BURNSIDE ST.

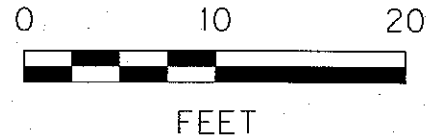

ROW FILE NO. 42
TAX LOT 1N1E35CB 6700

| | | | | |
|----------|------|--|--------------------------|---------------|
| | | CHECKED BY RDP | DESIGNED BY HHPR TEAM | DATE APPROVED |
| | | | CAD BY HHPR CAD | DIV ENGINEER |
| | | PROJECT NO. 37642 | SECTION #### | |
| | | FHWA PROJECT NUMBER X-CM-XXXX-(PDX) | | |
| NO. | DATE | DESCRIPTION | APPD. | |
| REVISION | | | | |



Harper Houf Peterson Righellis Inc.
ENGINEERS • PLANNERS
LANDSCAPE ARCHITECTS • SURVEYORS
205 SE Spokane Street, Suite 200, Portland, OR 97202
phone: 503.221.1131 www.hhpr.com fax: 503.221.1171

APPROVALS:

| | |
|-------------------|------------------------------|
| DIVISION ENGINEER | REG. PROF. ENGR. NO. 51538PE |
| CITY ENGINEER | REG. PROF. ENGR. NO. 51538PE |

CITY OF PORTLAND
OFFICE OF TRANSPORTATION

SAM ADAMS
STEVE TOWNSEN, P.E.

COMMISSIONER
CITY ENGINEER

Temporary Construction Easement
811 E. BURNSIDE ST.

NE 3RD AVE - NE 14TH AVE (PORTLAND) SEC
E BURNSIDE - NE COUCH COUPLET

SHEET NO. **1**

EXHIBIT 24

TEMPORARY CONSTRUCTION EASEMENT
AREA = 53 S.F.

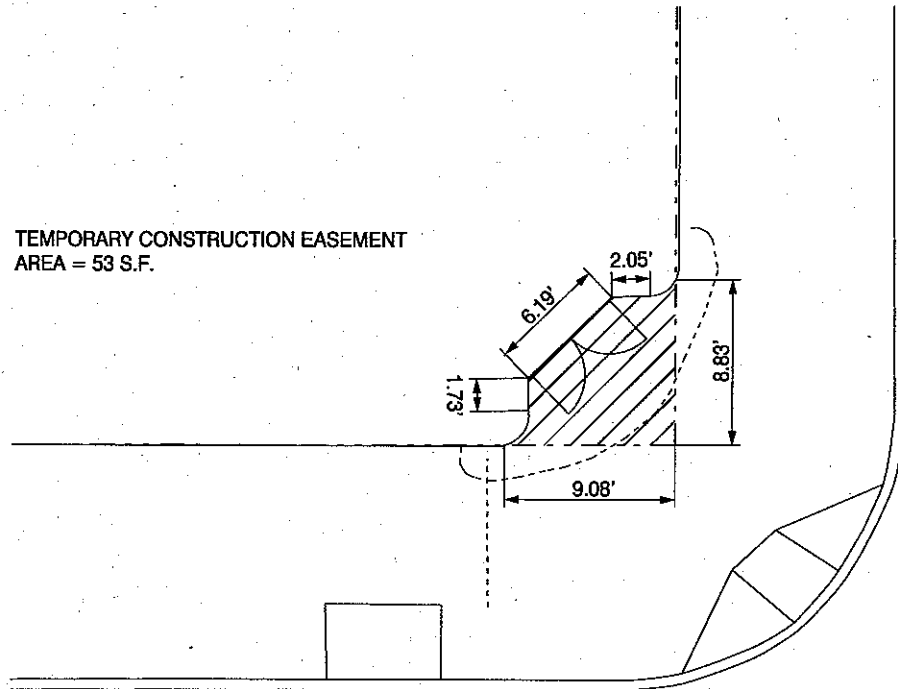

N.E. 9TH AVE.

E. BURNSIDE ST.

ROW FILE NO. 43
TAX LOT 1N1E35CB 6600

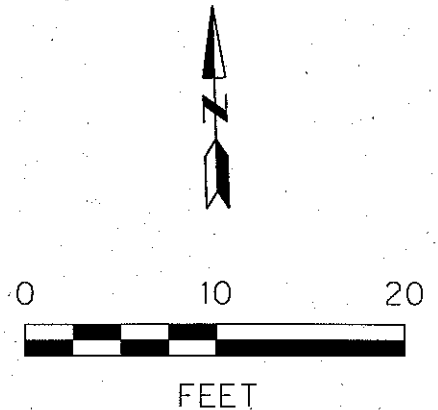

| | | | | | | |
|----------|------|-------------|-------|--|--------------------------|---------------|
| | | | | CHECKED BY RDP | DESIGNED BY HHPR TEAM | DATE APPROVED |
| | | | | | CAD. BY HHPR CAD | DIV. ENGINEER |
| | | | | PROJECT NO. 37642 | SECTION #### | |
| NO. | DATE | DESCRIPTION | APPD. | FHWA PROJECT NUMBER X-CM-XXXX-(PDX) | | |
| REVISION | | | | | | |



Harper Houf Peterson Righellis Inc.
ENGINEERS • PLANNERS
LANDSCAPE ARCHITECTS • SURVEYORS
205 SE Spokane Street, Suite 200, Portland, OR 97202
phone: 503.221.1131 www.hhpr.com fax: 503.221.1171

APPROVALS:

| | |
|-------------------|------------------------------|
| DIVISION ENGINEER | REG. PROF. ENGR. NO. 51538PE |
| CITY ENGINEER | REG. PROF. ENGR. NO. 51538PE |

CITY OF PORTLAND
OFFICE OF TRANSPORTATION

SAM ADAMS
STEVE TOWNSEN, P.E.

COMMISSIONER
CITY ENGINEER

Temporary Construction Easement
835 E. BURNSIDE ST.

NE 3RD AVE - NE 14TH AVE (PORTLAND) SEC
E BURNSIDE - NE COUCH COUPLET

SHEET NO. **1**

EXHIBIT 25

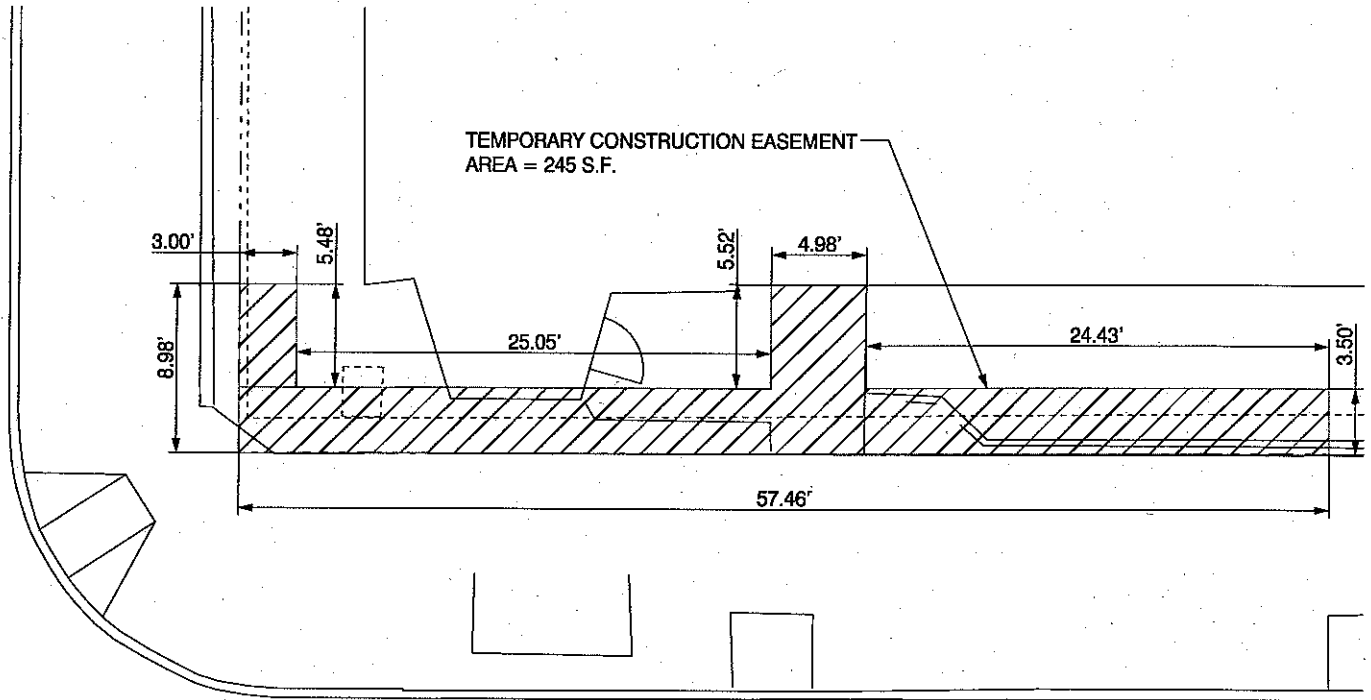

N.E. 9TH AVE.

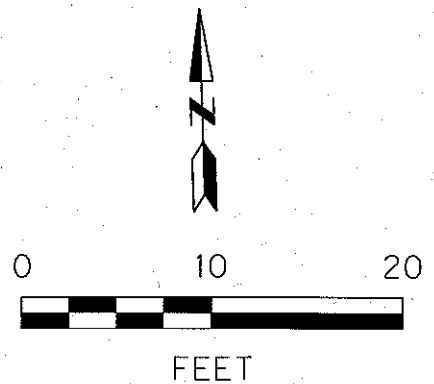

E. BURNSIDE ST.

ROW FILE NO. 44
TAX LOT 1N1E35CA 6100



| | | | | | | |
|----------|------|----------------------|--------------------------|---------------|---|--|
| | | CHECKED BY RDP | DESIGNED BY HHPR TEAM | DATE APPROVED |  |  Harper Houf Peterson Righellis Inc. <small>ENGINEERS • PLANNERS LANDSCAPE ARCHITECTS • SURVEYORS 205 SE Spokane Street, Suite 200, Portland, OR 97202 phone: 503.221.1131 www.hhpr.com fax: 503.221.1171</small> |
| | | | CAD BY HHPR CAD | DIV ENGINEER | | |
| | | PROJECT NO. 37642 | SECTION #### | | | |
| NO. | DATE | DESCRIPTION | | APPD. | FHWA PROJECT NUMBER X-CM-XXXX-(PDX) | |
| REVISION | | | | | | |

APPROVALS:

DIVISION ENGINEER REG. PROF. ENGR. NO. 51538PE

CITY ENGINEER REG. PROF. ENGR. NO. 51538PE



SAM ADAMS
STEVE TOWNSEN, P.E.

COMMISSIONER
CITY ENGINEER

Temporary Construction Easement
909 E. BURNSIDE ST.

NE 3RD AVE - NE 14TH AVE (PORTLAND) SEC

E BURNSIDE - NE COUCH COUPLET

SHEET NO.

1

EXHIBIT 26

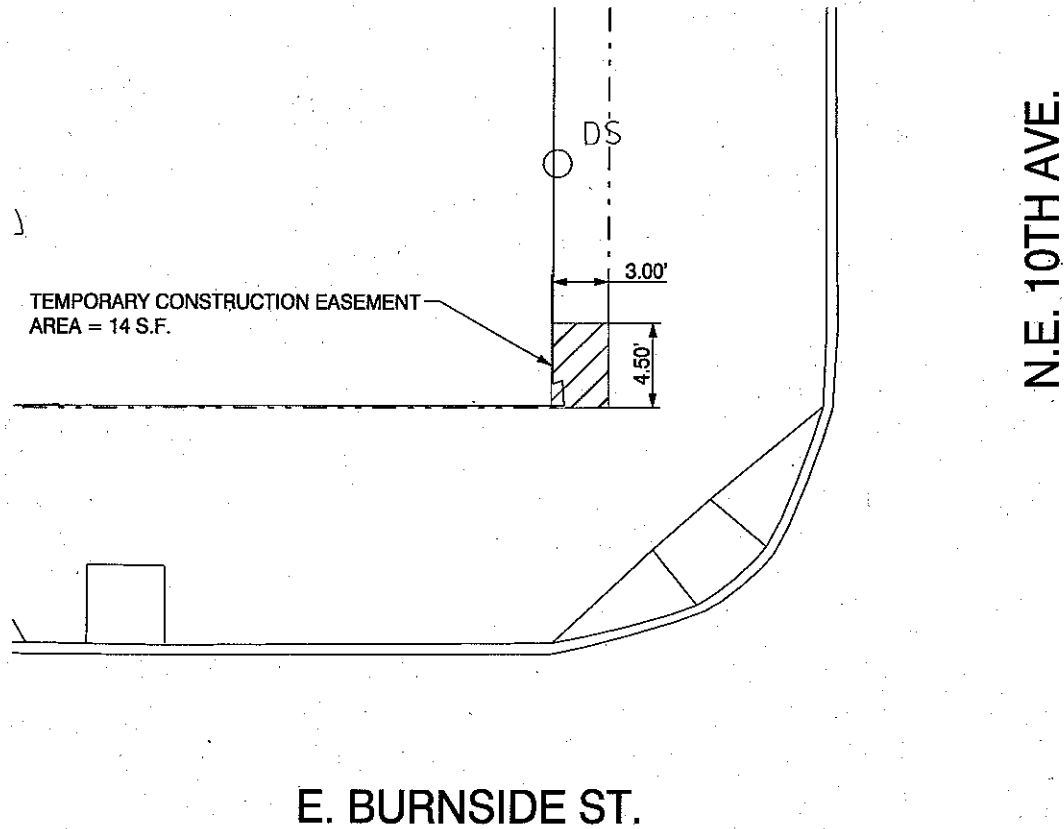

ROW FILE NO. 45
TAX LOT 1N1E35CA 6000



| | | | | | | | | | |
|-------------------|------|--|--------------------------|--|---|------------------------------|--|---|--|
| | | CHECKED BY RDP | DESIGNED BY HHPR TEAM | DATE APPROVED |  <p>Harper Houf Peterson Righellis Inc. ENGINEERS • PLANNERS LANDSCAPE ARCHITECTS • SURVEYORS 205 SE Spokane Street, Suite 200, Portland, OR 97202 phone: 503.221.1131 www.hhpr.com fax: 503.221.1171</p> | | | | |
| | | | CAO BY HHPR CAD | DIV ENGINEER | | | | | |
| | | PROJECT NO. 37642 | 1/2 SECTION #### | | | | | | |
| NO. | DATE | DESCRIPTION | APPD. | FHWA PROJECT NUMBER X-CM-XXXX-(PDX) | | | | | |
| REVISION | | | | | | | | | |
| APPROVALS: | |  <p>CITY OF PORTLAND OFFICE OF TRANSPORTATION</p> | | <p><i>Temporary Construction Easement</i> 949 E. BURNSIDE ST.</p> | | | | | |
| DIVISION ENGINEER | | | | | | REG. PROF. ENGR. NO. 51538PE | | NE 3RD AVE - NE 14TH AVE (PORTLAND) SEC | |
| CITY ENGINEER | | | | | | REG. PROF. ENGR. NO. 51538PE | | E BURNSIDE - NE COUCH COUPLER | |
| | | <p>SAM ADAMS STEVE TOWNSEN, P.E.</p> | | <p>COMMISSIONER CITY ENGINEER</p> | | | | | |
| | | | | SHEET NO. 1 | | | | | |

EXHIBIT 27

N.E. 10TH AVE.



E. BURNSIDE ST.

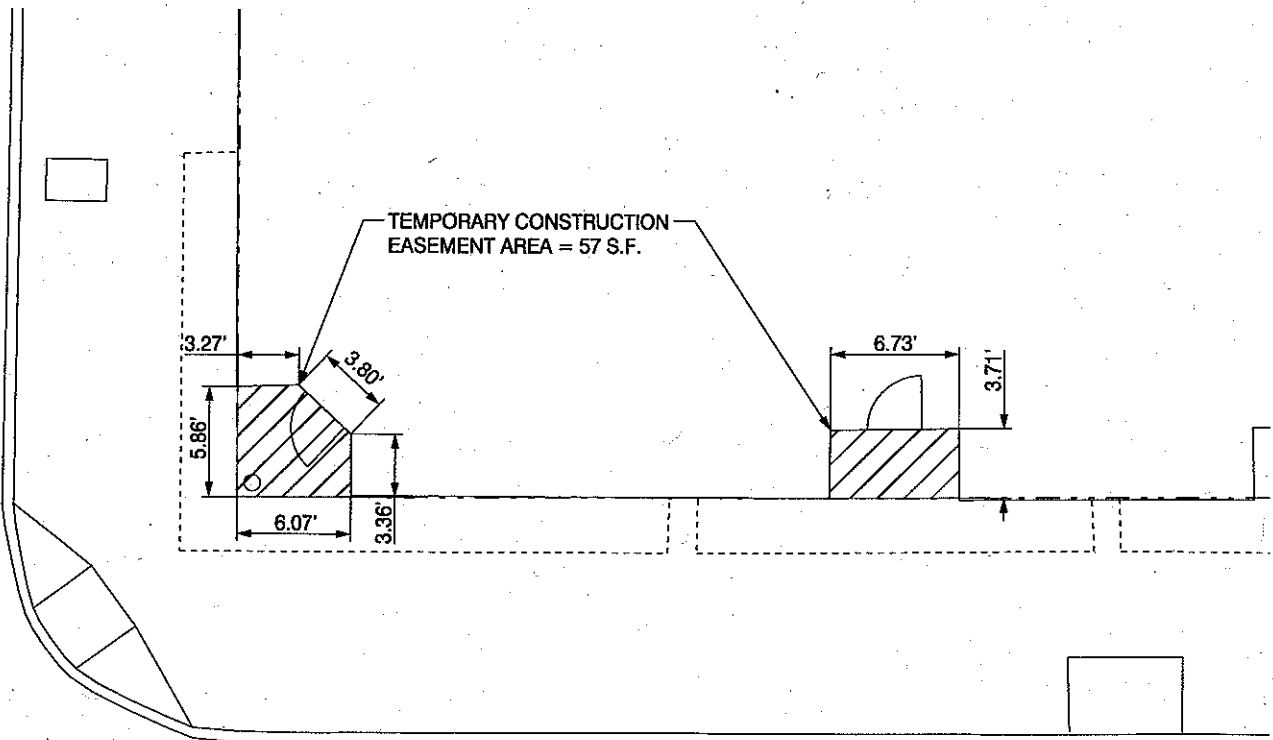
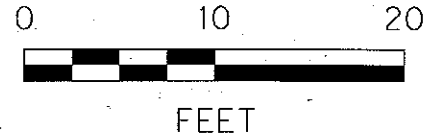

ROW FILE NO. 46
TAX LOT 1N1E35CA 5900

| | | | |
|-----|------|-------------|-------|
| NO. | DATE | DESCRIPTION | APPR. |
| | | REVISION | |

| | | |
|--|--------------------------|---------------|
| CHECKED BY RDP | DESIGNED BY HHPR TEAM | DATE APPROVED |
| | CAD BY HHPR CAD | DIV ENGINEER |
| PROJECT NO. 37642 | SECTION ### | |
| FHWA PROJECT NUMBER X-CM-XXXX-(PDX) | | |



Harper Houf Peterson Righellis Inc.
ENGINEERS • PLANNERS
LANDSCAPE ARCHITECTS • SURVEYORS
205 SE Spokane Street, Suite 200, Portland, OR 97202
phone: 503.221.1131 www.hhpr.com fax: 503.221.1171

APPROVALS:

| | |
|-------------------|------------------------------|
| DIVISION ENGINEER | REG. PROF. ENGR. NO. 51538PE |
| CITY ENGINEER | REG. PROF. ENGR. NO. 51538PE |

CITY OF PORTLAND OFFICE OF TRANSPORTATION
SAM ADAMS
STEVE TOWNSEN, P.E.
COMMISSIONER
CITY ENGINEER

Temporary Construction Easement
1001-1015 E. BURNSIDE ST.
NE 3RD AVE - NE 14TH AVE (PORTLAND) SEC
E BURNSIDE - NE COUCH COUplet

SHEET NO. **1**

EXHIBIT 28

N.E. COUCH ST.

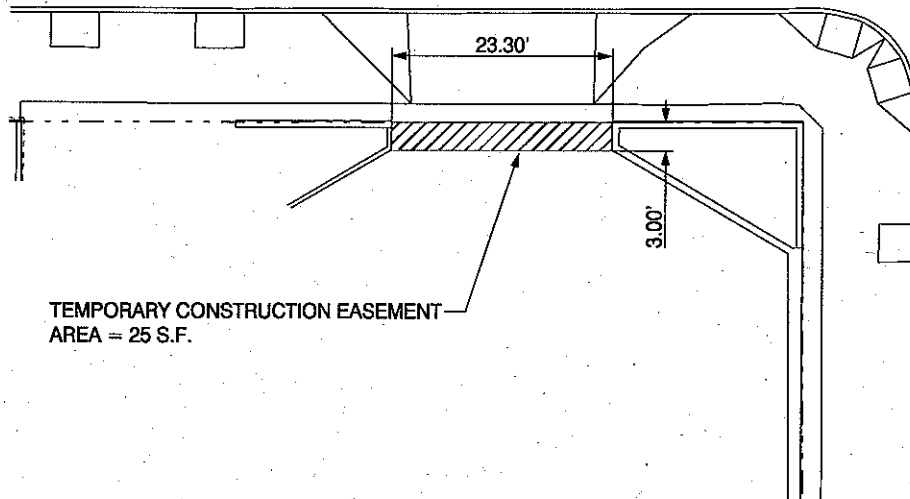

N.E. 11TH AVE.

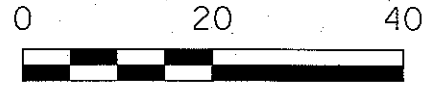

ROW FILE NO. 47
TAX LOT 1N1E35CA 5800

| | | | | | | |
|-----|------|-------------|-------|---|---------------------------------|---------------|
| | | | | CHECKED BY <i>RDP</i> | DESIGNED BY <i>HHPR TEAM</i> | DATE APPROVED |
| | | | | | CAD BY <i>HHPR CAD</i> | DIV ENGINEER |
| | | | | PROJECT NO. <i>37642</i> | SECTION <i>###</i> | |
| | | | | FHWA PROJECT NUMBER <i>X-CM-XXXX-(PDX)</i> | | |
| NO. | DATE | DESCRIPTION | APPD. | REVISION | | |



Harper Houf Peterson Righellis Inc.
ENGINEERS • PLANNERS
LANDSCAPE ARCHITECTS • SURVEYORS
205 SE Spokane Street, Suite 200, Portland, OR 97202
phone: 503.221.1131 www.hhpr.com fax: 503.221.1171

APPROVALS:

DIVISION ENGINEER REG. PROF. ENGR. NO. 5153BPE

CITY ENGINEER REG. PROF. ENGR. NO. 5153BPE

CITY OF PORTLAND
OFFICE OF TRANSPORTATION

SAM ADAMS
STEVE TOWNSEN, P.E.

COMMISSIONER
CITY ENGINEER

Temporary Construction Easement
1030 N.E. COUCH STREET

NE 3RD AVE - NE 14TH AVE (PORTLAND) SEC

E BURNSIDE - NE COUCH COUPLET

SHEET NO. **1**

EXHIBIT 29

N.E. 11TH AVE.

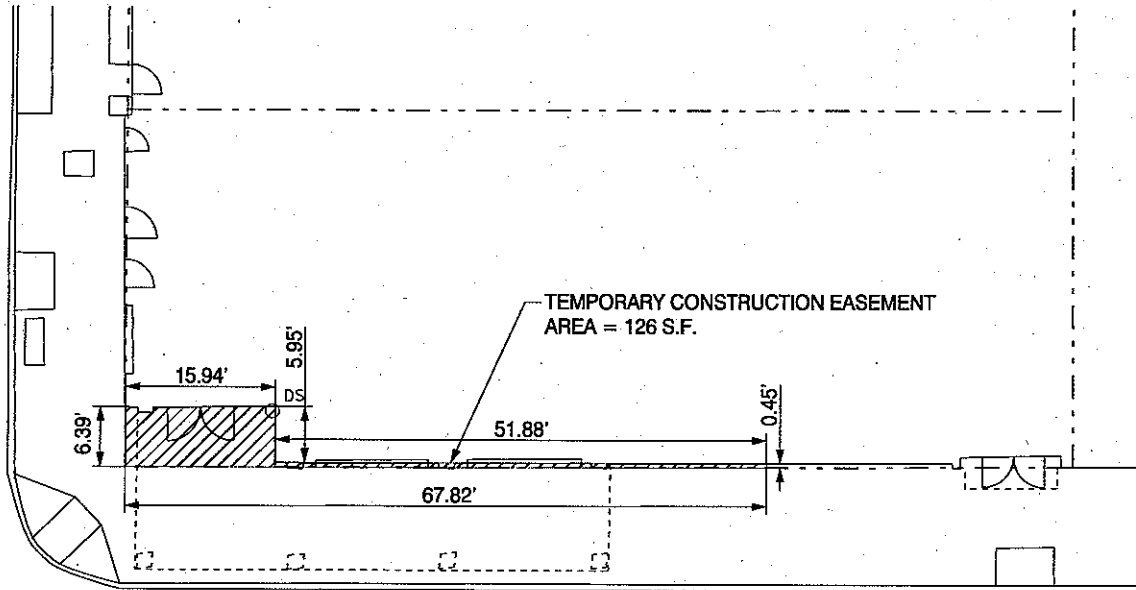

TEMPORARY CONSTRUCTION EASEMENT
AREA = 126 S.F.

E. BURNSIDE ST.

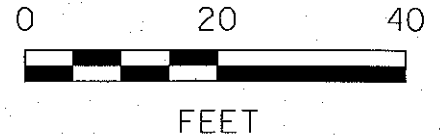

ROW FILE NO. 49
TAX LOT 1N1E35CA 5200

| | | | | | | |
|-----|------|-------------|-------|--|--------------------------|---------------|
| | | | | CHECKED BY RDP | DESIGNED BY HHPR TEAM | DATE APPROVED |
| | | | | | CAD BY HHPR CAD | DIV ENGINEER |
| | | | | PROJECT NO. 37642 | SECTION ### | |
| | | | | FHWA PROJECT NUMBER X-CM-XXXX-(PDX) | | |
| NO. | DATE | DESCRIPTION | APPO. | | | |
| | | REVISION | | | | |



Harper Houf Peterson Righellis Inc.
ENGINEERS • PLANNERS
LANDSCAPE ARCHITECTS • SURVEYORS
205 SE Spokane Street, Suite 200, Portland, OR 97202
phone: 503.221.1131 www.hhpr.com fax: 503.221.1171

APPROVALS:

DIVISION ENGINEER _____ REG. PROF. ENGR. NO. 5153BPE

CITY ENGINEER _____ REG. PROF. ENGR. NO. 5153APE

CITY OF PORTLAND
OFFICE OF TRANSPORTATION

SAM ADAMS
STEVE TOWNSEN, P.E.

COMMISSIONER
CITY ENGINEER

Temporary Construction Easement
1111 E. BURNSIDE ST.

NE 3RD AVE - NE 14TH AVE (PORTLAND) SEC
E BURNSIDE - NE COUCH COUplet

SHEET NO. **1**

EXHIBIT 30

N.E. COUCH ST.

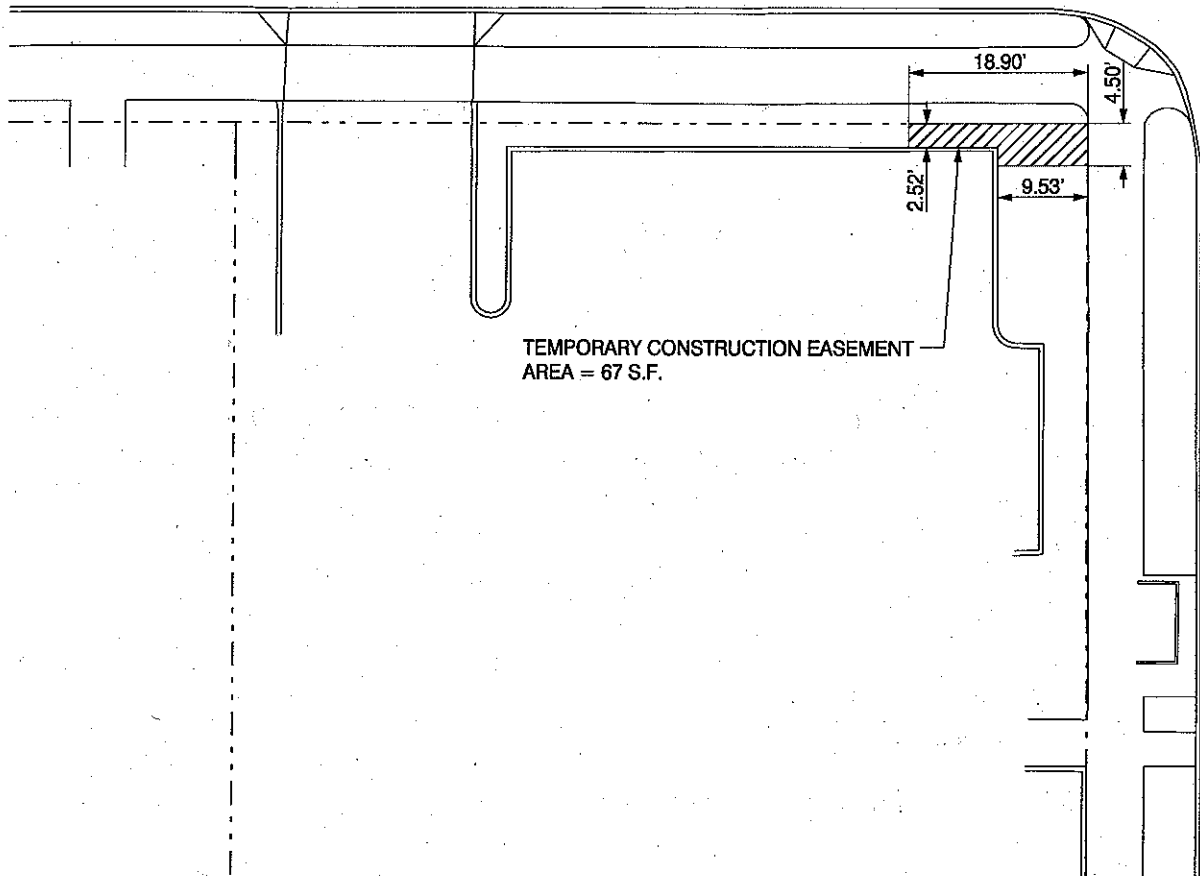

TEMPORARY CONSTRUCTION EASEMENT
AREA = 67 S.F.

N.E. 12TH AVE.

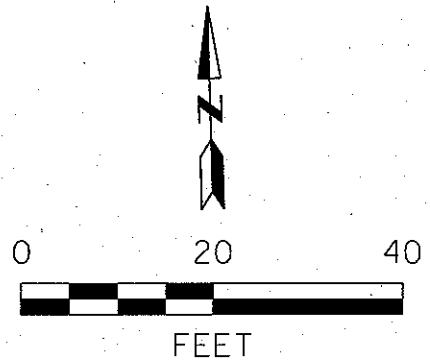

ROW FILE NO. 50
TAX LOT 1N1E35CA 5201

| | | | | |
|----------|------|---|---------------------------------|---------------|
| | | CHECKED BY <i>RDP</i> | DESIGNED BY <i>HHPR TEAM</i> | DATE APPROVED |
| | | | CAD BY <i>HHPR CAD</i> | DIV ENGINEER |
| | | PROJECT NO. <i>37642</i> | 1/4 SECTION <i>####</i> | |
| | | FHWA PROJECT NUMBER <i>X-CM-XXXX-(PDX)</i> | | |
| NO. | DATE | DESCRIPTION | APPD. | |
| REVISION | | | | |



**Harper
Houf Peterson
Righellis Inc.**

ENGINEERS • PLANNERS
LANDSCAPE ARCHITECTS • SURVEYORS

205 SE Spokane Street, Suite 200, Portland, OR 97202
phone: 503.221.1131 www.hhpr.com fax: 503.221.1171

APPROVALS:

| | |
|-------------------|------------------------------|
| DIVISION ENGINEER | REG. PROF. ENGR. NO. 5153BPE |
| CITY ENGINEER | REG. PROF. ENGR. NO. 5153BPE |

**CITY OF PORTLAND
OFFICE OF
TRANSPORTATION**

SAM ADAMS
STEVE TOWNSEN, P.E.

COMMISSIONER
CITY ENGINEER

**Temporary Construction Easement
21 N.E. 12TH AVENUE**

NE 3RD AVE - NE 14TH AVE (PORTLAND) SEC
E BURNSIDE - NE COUCH COUPLER

SHEET NO. **1**

N.E. COUCH ST.

N.E. 12TH AVE.

N.E. 13TH AVE.

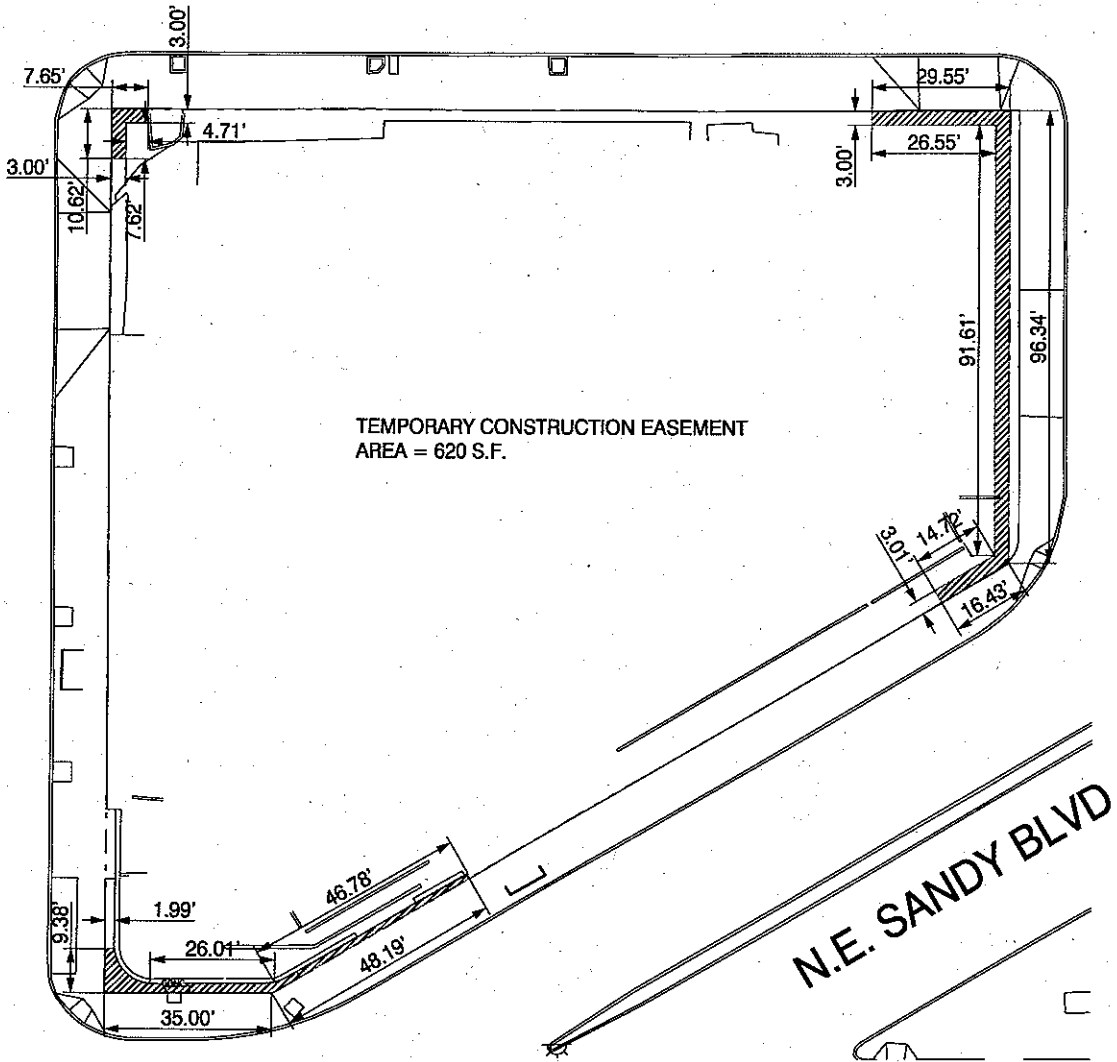

TEMPORARY CONSTRUCTION EASEMENT
AREA = 620 S.F.

N.E. SANDY BLVD.

ROW FILE NO. 51
TAX LOT 1N1E35CA 5100



| | | | | | | |
|----------|------|-------------|-------|--|--------------------------|---------------|
| | | | | CHECKED BY RDP | DESIGNED BY HHPR TEAM | DATE APPROVED |
| | | | | | CAD BY HHPR CAD | DIV ENGINEER |
| | | | | PROJECT NO. 37642 | SECTION ### | |
| NO. | DATE | DESCRIPTION | APPO. | FHWA PROJECT NUMBER X-CM-XXXX-(PDX) | | |
| REVISION | | | | | | |



Harper Houf Peterson Righellis Inc.
ENGINEERS • PLANNERS
LANDSCAPE ARCHITECTS • SURVEYORS
205 SE Spokane Street, Suite 200, Portland, OR 97202
phone: 503.221.1131 www.hhpr.com fax: 503.221.1171

APPROVALS:

| | |
|-------------------|------------------------------|
| DIVISION ENGINEER | REG. PROF. ENCR. NO. 5153BPE |
| CITY ENGINEER | REG. PROF. ENCR. NO. 5153BPE |

CITY OF PORTLAND
OFFICE OF TRANSPORTATION

SAM ADAMS
STEVE TOWNSEN, P.E.

COMMISSIONER
CITY ENGINEER

Temporary Construction Easement
1221 N.E. COUCH ST.

NE 3RD AVE - NE 14TH AVE (PORTLAND) SEC
E BURNSIDE - NE COUCH COUPLER

SHEET NO. **1**

EXHIBIT 32

N.E. 13TH AVE.

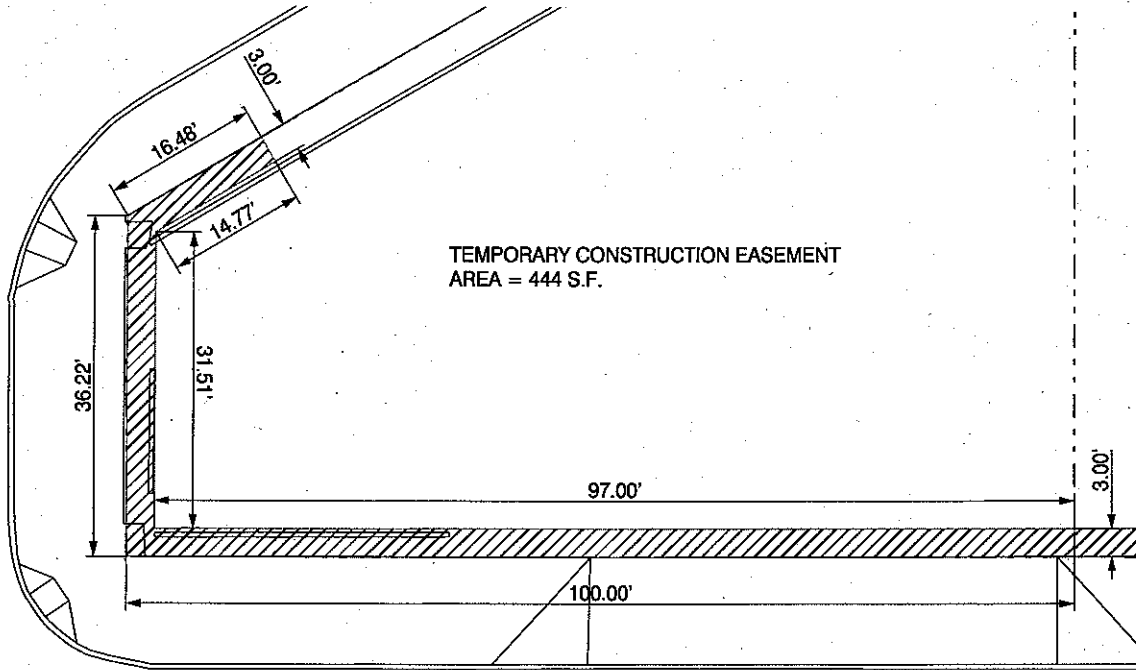

TEMPORARY CONSTRUCTION EASEMENT
AREA = 444 S.F.

E. BURNSIDE ST.



ROW FILE NO. 52
TAX LOT 1N1E35CA 5000

| | | | | |
|---------------------|--|-------------|-------------|---------------|
| NO. | | DATE | DESCRIPTION | APPD. |
| REVISION | | | | |
| CHECKED BY | | DESIGNED BY | | DATE APPROVED |
| RDP | | HHPR TEAM | | |
| | | CAD BY | | DIV ENGINEER |
| | | HHPR CAD | | |
| PROJECT NO. | | 1/4 SECTION | | |
| 37642 | | #### | | |
| FHWA PROJECT NUMBER | | | | |
| X-CM-XXXX-(PDX) | | | | |



Harper Houf Peterson Righellis Inc.
ENGINEERS • PLANNERS
LANDSCAPE ARCHITECTS • SURVEYORS
205 SE Spokane Street, Suite 200, Portland, OR 97202
phone: 503.221.1131 www.hhpr.com fax: 503.221.1171

APPROVALS:

| | |
|-------------------|------------------------------|
| DIVISION ENGINEER | REG. PROF. ENGR. NO. 51538PE |
| CITY ENGINEER | REG. PROF. ENGR. NO. 51538PE |

CITY OF PORTLAND
OFFICE OF TRANSPORTATION

SAM ADAMS
STEVE TOWNSEN, P.E.

COMMISSIONER
CITY ENGINEER

Temporary Construction Easement
1338 N.E. SANDY BLVD.

NE 3RD AVE - NE 14TH AVE (PORTLAND) SEC
E BURNSIDE - NE COUCH COUPLER

SHEET NO. **1**

EXHIBIT 33

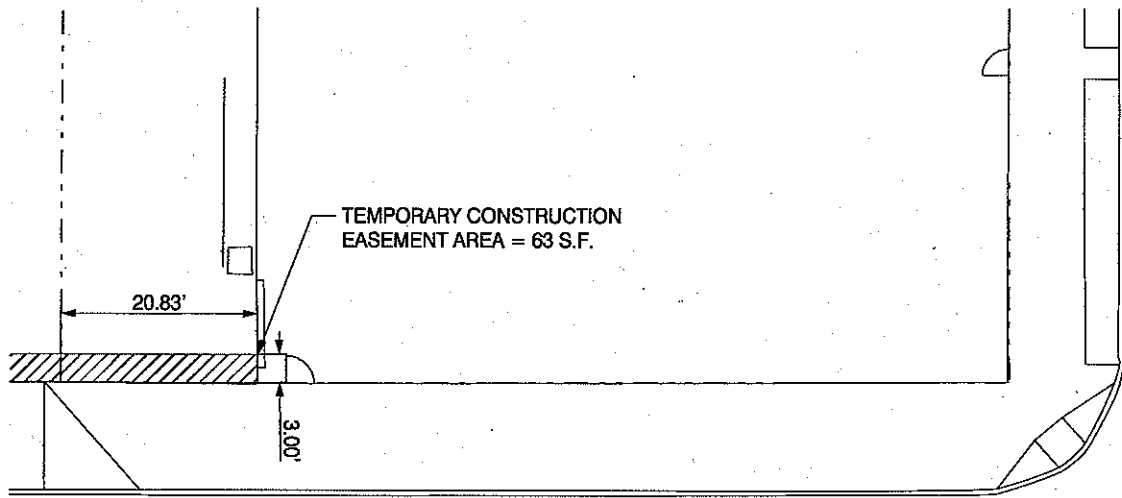

N.E. 14TH AVE.

E. BURNSIDE ST.

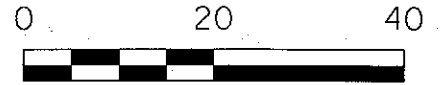

FEET

ROW FILE NO. 53
TAX LOT 1N1E35CA 4900

| | | | | | | |
|-----|------|-------------|-------|--|--------------------------|---------------|
| | | | | CHECKED BY RDP | DESIGNED BY HHPR TEAM | DATE APPROVED |
| | | | | | CAD BY HHPR CAD | DIV ENGINEER |
| | | | | PROJECT NO. 37642 | SECTION ### | |
| | | | | FWHA PROJECT NUMBER X-CM-XXXX-(PDX) | | |
| NO. | DATE | DESCRIPTION | APPD. | REVISION | | |



Harper Houf Peterson Righellis Inc.
ENGINEERS • PLANNERS
LANDSCAPE ARCHITECTS • SURVEYORS
205 SE Spokane Street, Suite 200, Portland, OR 97202
phone: 503.221.1131 www.hhpr.com fax: 503.221.1171

APPROVALS:

DIVISION ENGINEER _____ REG. PROF. ENGR. NO. 51538PE

CITY ENGINEER _____ REG. PROF. ENGR. NO. 51538PE

CITY OF PORTLAND
OFFICE OF TRANSPORTATION

SAM ADAMS
STEVE TOWNSEN, P.E.

COMMISSIONER
CITY ENGINEER

Temporary Construction Easement
1338 N.E. SANDY BLVD.

NE 3RD AVE - NE 14TH AVE (PORTLAND) SEC

E BURNSIDE - NE COUCH COUPLET

SHEET NO. **1**

EXHIBIT 34

N.E. COUCH ST.

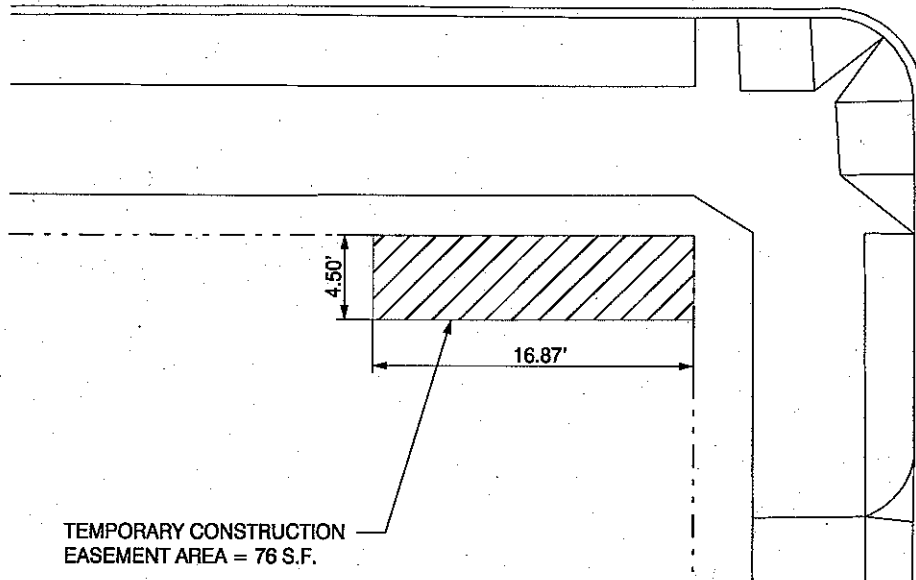

TEMPORARY CONSTRUCTION
EASEMENT AREA = 76 S.F.

N.E. 7TH AVE.

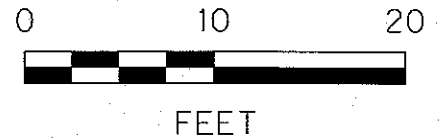

ROW FILE NO. 64
TAX LOT 1N1E35CB 7500

| | | | | |
|-----|------|---|---------------------------------|---------------|
| | | CHECKED BY <i>ADP</i> | DESIGNED BY <i>HHPR TEAM</i> | DATE APPROVED |
| | | | CAD BY <i>HHPR CAD</i> | DIV ENGINEER |
| | | PROJECT NO. 37642 | SECTION #### | |
| | | FHWA PROJECT NUMBER <i>X-CM-XXXX-(PDX)</i> | | |
| NO. | DATE | DESCRIPTION | APPD. | |
| | | REVISION | | |



**Harper
Houf Peterson
Righellis Inc.**
ENGINEERS • PLANNERS
LANDSCAPE ARCHITECTS • SURVEYORS
205 SE Spokane Street, Suite 200, Portland, OR 97202
phone: 503.221.1131 www.hhpr.com fax: 503.221.1171

APPROVALS:

DIVISION ENGINEER _____ REG. PROF. ENGR. NO. 51538PE

CITY ENGINEER _____ REG. PROF. ENGR. NO. 51538PE

**CITY OF
PORTLAND
OFFICE OF
TRANSPORTATION**

SAM ADAMS
STEVE TOWNSEN, P.E.

COMMISSIONER
CITY ENGINEER

**Temporary Construction Easement
21 N.E. 7TH AVE.**

NE 3RD AVE - NE 14TH AVE (PORTLAND) SEC
E BURNSIDE - NE COUCH COUPLER

SHEET NO.
1

N.E. COUCH ST.

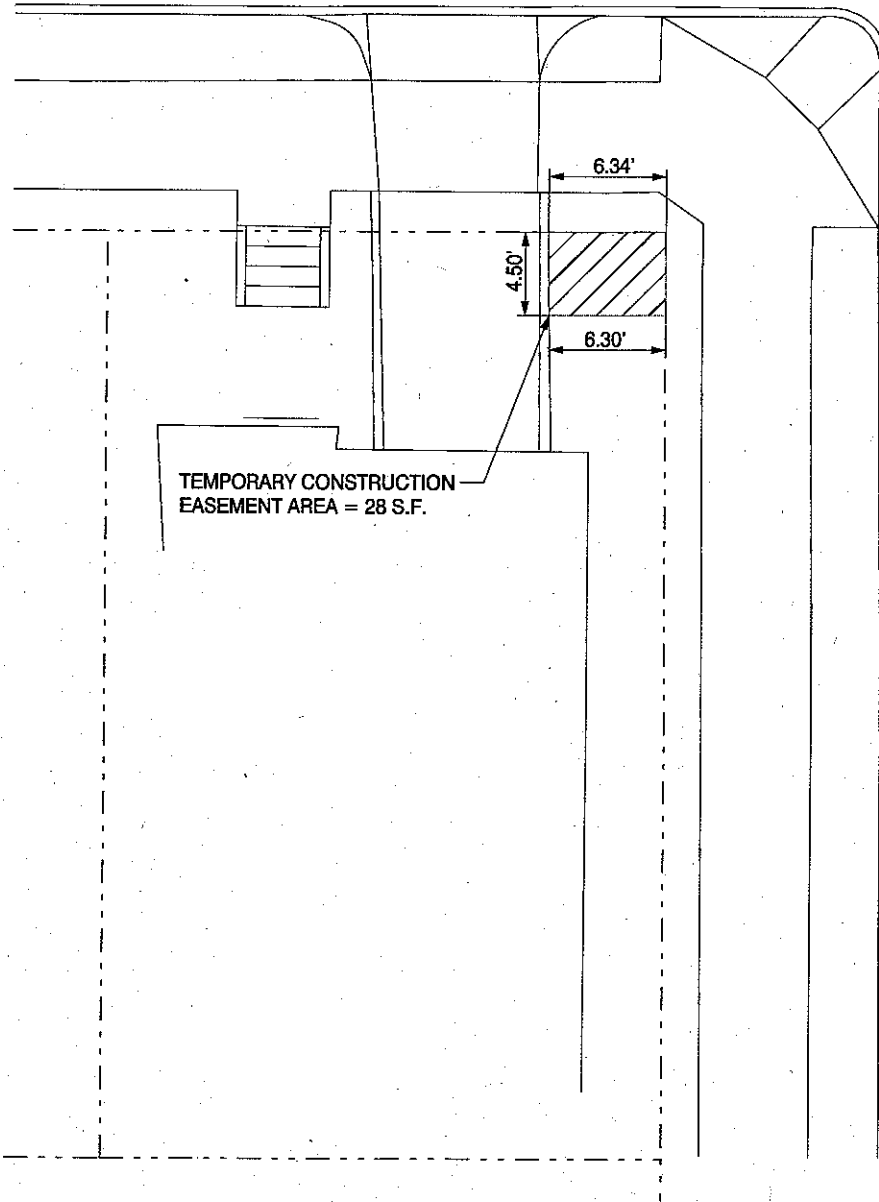

TEMPORARY CONSTRUCTION
EASEMENT AREA = 28 S.F.

N.E. 8TH AVE.



ROW FILE NO. 67
TAX LOT 1N1E35CB 6900



| | | | | | | |
|---|------|------------------------------|-------|---|---------------------------------|-----------------------|
| | | | | CHECKED BY <i>RDP</i> | DESIGNED BY <i>HHPR TEAM</i> | DATE APPROVED |
| | | | | | CAD BY <i>HHPR CAD</i> | DIV ENGINEER |
| | | | | PROJECT NO. <i>37642</i> | SECTION <i>###</i> | |
| | | | | FHWA PROJECT NUMBER <i>X-CM-XXXX-(PDX)</i> | | |
| NO. | DATE | DESCRIPTION | APPD. | REVISION | | |
| APPROVALS: | | | |  Harper Houf Peterson Righellis Inc. <small>ENGINEERS • PLANNERS LANDSCAPE ARCHITECTS • SURVEYORS 205 SE Spokane Street, Suite 200, Portland, OR 97202 phone: 503.221.1131 www.hhpr.com fax: 503.221.1171</small> | | |
| DIVISION ENGINEER | | REG. PROF. ENGR. NO. 51538PE | | | | |
| CITY ENGINEER | | REG. PROF. ENGR. NO. 51538PE | | | | |
|  CITY OF PORTLAND OFFICE OF TRANSPORTATION SAM ADAMS STEVE TOWNSEN, P.E. | | | | Temporary Construction Easement 736 N.E. COUCH STREET NE 3RD AVE - NE 14TH AVE (PORTLAND) SEC E BURNSIDE - NE COUCH COUPLET | | |
| | | | | COMMISSIONER CITY ENGINEER | | SHEET NO. 1 |

EXHIBIT 36

N.E. COUCH ST.

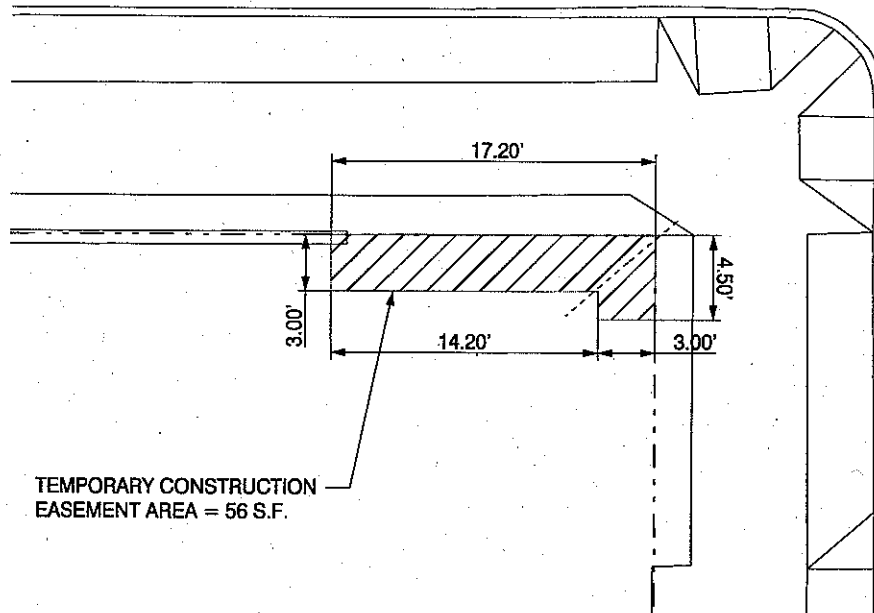

TEMPORARY CONSTRUCTION
EASEMENT AREA = 56 S.F.

N.E. 9TH AVE.



ROW FILE NO. 70
TAX LOT 1N1E35CB 6400

| | | | | | | | |
|-----|--|----------------------|--|--|--|---------------|--|
| | | CHECKED BY RDP | | DESIGNED BY HHPR TEAM | | DATE APPROVED | |
| | | | | CAD BY HHPR CAD | | DIV ENGINEER | |
| | | PROJECT NO. 37642 | | SECTION ### | | | |
| NO. | | DATE | | DESCRIPTION | | APPD. | |
| | | | | REVISION | | | |
| | | | | FHWA PROJECT NUMBER X-CM-XXXX-(PDX) | | | |



**Harper
Houf Peterson
Righellis Inc.**
ENGINEERS • PLANNERS
LANDSCAPE ARCHITECTS • SURVEYORS
205 SE Spokane Street, Suite 200, Portland, OR 97202
phone: 503.221.1131 www.hpr.com fax: 503.221.1171

APPROVALS:

DIVISION ENGINEER _____ REG. PROF. ENGR. NO. 51538PE

CITY ENGINEER _____ REG. PROF. ENGR. NO. 51538PE

**CITY OF
PORTLAND
OFFICE OF
TRANSPORTATION**

SAM ADAMS
STEVE TOWNSEN, P.E.

COMMISSIONER
CITY ENGINEER

**Temporary Construction Easement
835 E. BURNSIDE ST.**

NE 3RD AVE - NE 14TH AVE (PORTLAND) SEC
E BURNSIDE - NE COUCH COUPLET

SHEET NO. **1**

EXHIBIT 37

N.E. COUCH ST.

N.E. 11TH AVE.

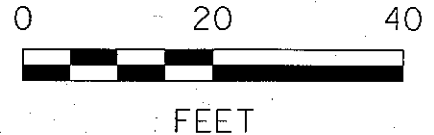
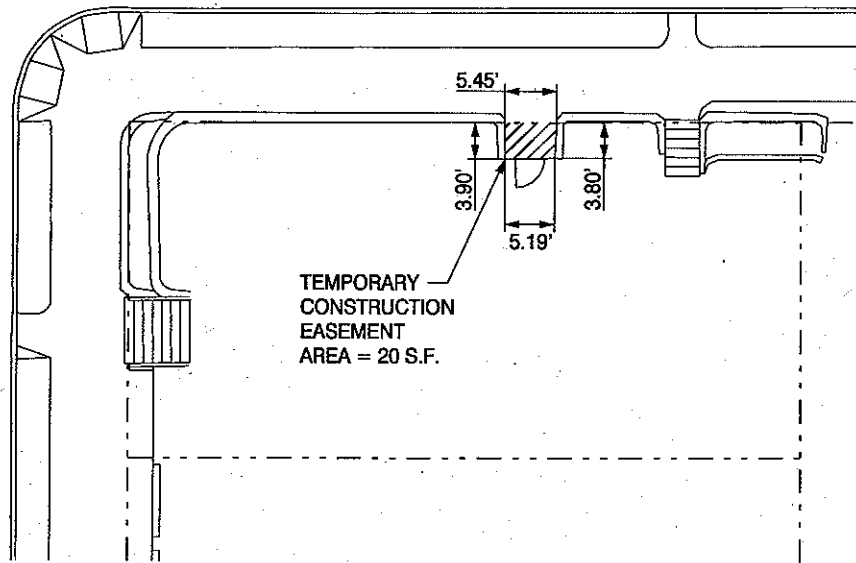

ROW FILE NO. 73
TAX LOT 1N1E35CA 5400

| | | | | | | | |
|--|--|----------------------|--|--|--|---------------|--|
| | | CHECKED BY RDP | | DESIGNED BY HHPR TEAM | | DATE APPROVED | |
| | | | | CAD BY HHPR CAD | | DIV ENGINEER | |
| | | PROJECT NO. 37642 | | 1/4 SECTION #### | | | |
| | | NO. | | DATE | | DESCRIPTION | |
| | | APPD. | | FWMA PROJECT NUMBER X-CM-XXXX-(PDX) | | REVISION | |



Harper Houf Peterson Righellis Inc.
ENGINEERS • PLANNERS
LANDSCAPE ARCHITECTS • SURVEYORS
205 SE Spokane Street, Suite 200, Portland, OR 97202
phone: 503.221.1131 www.hhpr.com fax: 503.221.1171

APPROVALS:

DIVISION ENGINEER _____ REG. PROF. ENGR. NO. 51538PE

CITY ENGINEER _____ REG. PROF. ENGR. NO. 51538PE

CITY OF PORTLAND
OFFICE OF TRANSPORTATION

SAM ADAMS
STEVE TOWNSEN, P.E.

COMMISSIONER
CITY ENGINEER

Temporary Construction Easement
32 N.E. 11TH AVE.

NE 3RD AVE - NE 14TH AVE (PORTLAND) SEC
E BURNSIDE - NE COUCH COUPLER

SHEET NO. **1**

N.E. COUCH ST.

N.E. 13TH AVE.

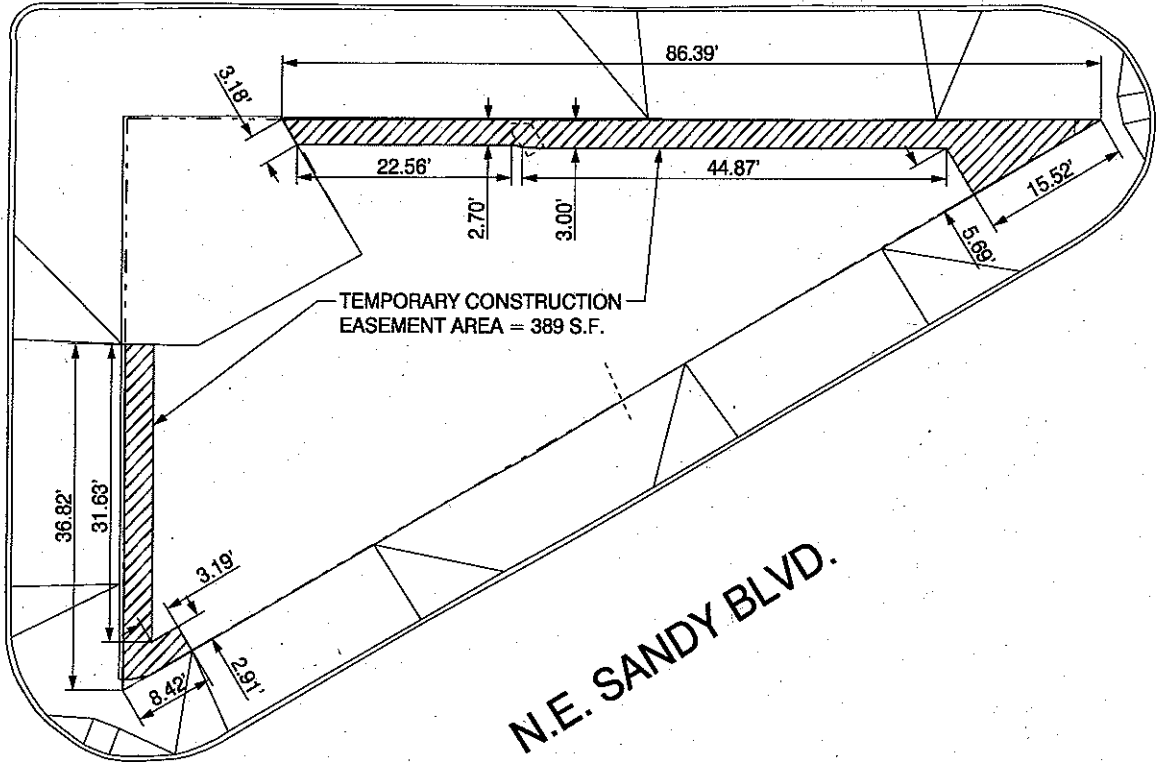

N.E. SANDY BLVD.

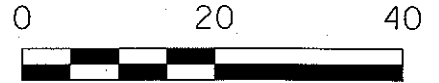

ROW FILE NO. 75
TAX LOT 1N1E35CA 4700

| | | | | | | |
|-----|------|-------------|-------|---|---------------------------------|---------------|
| | | | | CHECKED BY <i>RDP</i> | DESIGNED BY <i>HHPR TEAM</i> | DATE APPROVED |
| | | | | | CAD BY <i>HHPR CAD</i> | DIV ENGINEER |
| | | | | PROJECT NO. <i>37642</i> | SECTION <i>###</i> | |
| | | | | FHWA PROJECT NUMBER <i>X-CM-XXXX-(PDX)</i> | | |
| NO. | DATE | DESCRIPTION | APPO. | REVISION | | |



Harper Houf Peterson Righellis Inc.
ENGINEERS • PLANNERS
LANDSCAPE ARCHITECTS • SURVEYORS
205 SE Spokane Street, Suite 200, Portland, OR 97202
phone: 503.221.1131 www.hhpr.com fax: 503.221.1171

APPROVALS:

| | |
|-------------------|------------------------------|
| DIVISION ENGINEER | REG. PROF. ENGR. NO. 51538PE |
| CITY ENGINEER | REG. PROF. ENGR. NO. 51538PE |

CITY OF PORTLAND OFFICE OF TRANSPORTATION
SAM ADAMS
STEVE TOWNSEN, P.E.
COMMISSIONER
CITY ENGINEER

Temporary Construction Easement
1315 N.E. SANDY BLVD.
NE 3RD AVE - NE 14TH AVE (PORTLAND) SEC
E BURNSIDE - NE COUCH COUPLET

SHEET NO. **1**

EXHIBIT 39

N.E. ML KING JR. BLVD.

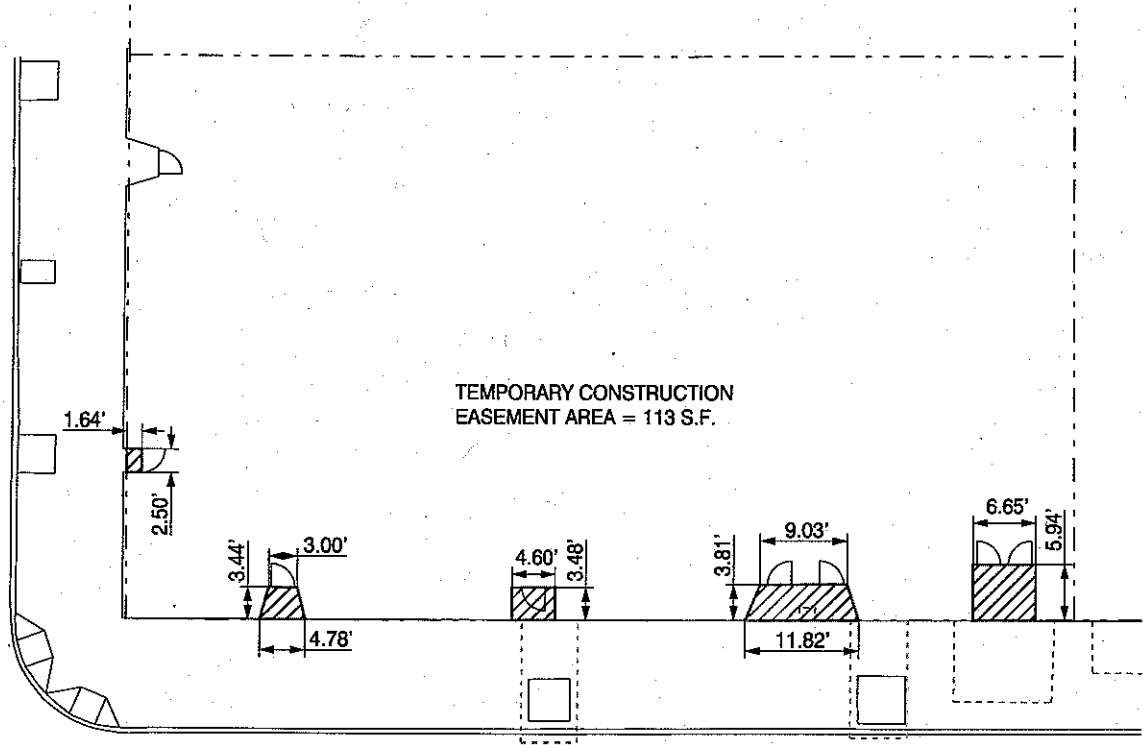

N.E. COUCH ST.

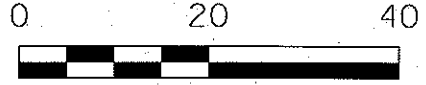

ROW FILE NO. 80
TAX LOT 1N1E35CB 3800

| NO. | DATE | DESCRIPTION | APPD. |
|-----|------|-------------|-------|
| | | | |
| | | | |
| | | | |
| | | | |
| | | | |

| | | |
|--|--------------------------|---------------|
| CHECKED BY RDP | DESIGNED BY HHPR TEAM | DATE APPROVED |
| PROJECT NO. 37642 | CAD BY HHPR CAD. | DIV ENGINEER |
| SECTION #### | | |
| FHWA PROJECT NUMBER X-CM-XXXX-(PDX) | | |



Harper Houf Peterson Righellis Inc.
ENGINEERS • PLANNERS
LANDSCAPE ARCHITECTS • SURVEYORS
205 SE Spokane Street, Suite 200, Portland, OR 97202
phone: 503.221.1131 www.hhpr.com fax: 503.221.1171

APPROVALS:

| | |
|-------------------|------------------------------|
| DIVISION ENGINEER | REG. PROF. ENGR. NO. 51538PE |
| CITY ENGINEER | REG. PROF. ENGR. NO. 51538PE |

CITY OF PORTLAND OFFICE OF TRANSPORTATION
SAM ADAMS
STEVE TOWNSEN, P.E.
COMMISSIONER
CITY ENGINEER

Temporary Construction Easement
100-110 N.E. ML KING JR. BLVD.
NE 3RD AVE - NE 14TH AVE (PORTLAND) SEC
E BURNSIDE - NE COUCH COUPLER

SHEET NO. **1**

EXHIBIT 40

N.E. ML KING JR. BLVD.

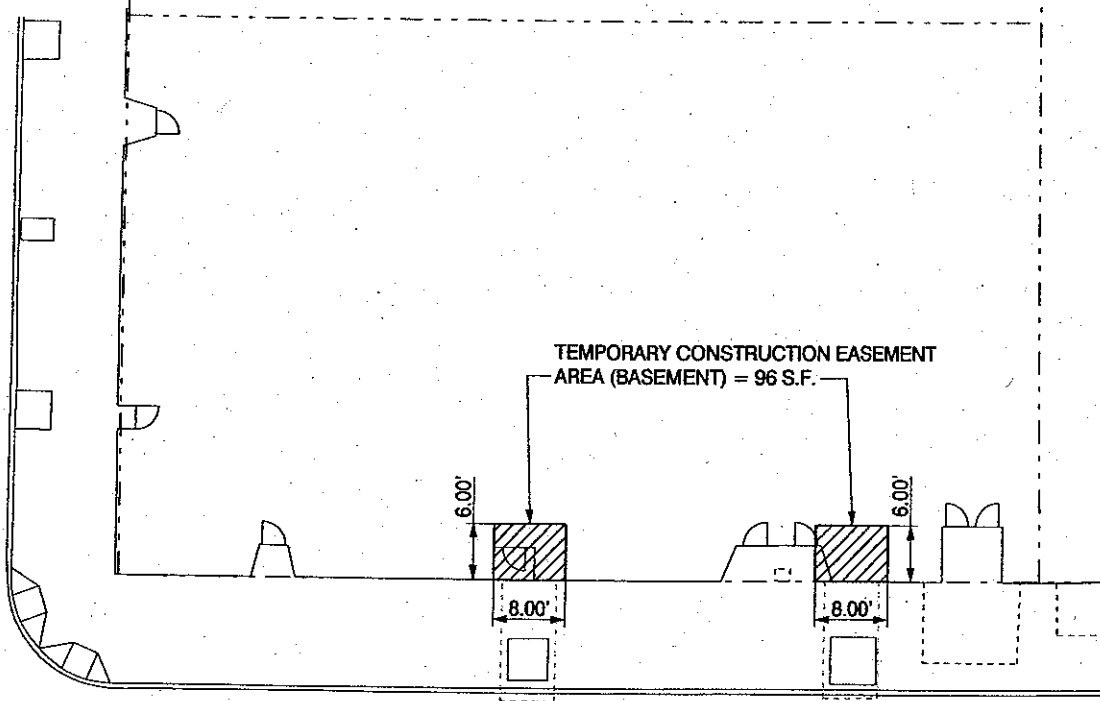

N.E. COUCH ST.

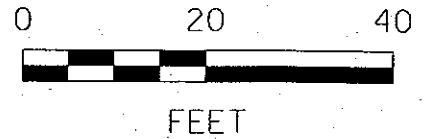

ROW FILE NO. 80A
TAX LOT 1N1E35CB 3800

| | | | | | | |
|-----|------|-------------|-------|--|--------------------------|---------------|
| NO. | DATE | DESCRIPTION | APPR. | CHECKED BY RDP | DESIGNED BY HHPR TEAM | DATE APPROVED |
| | | | | | CAD BY HHPR CAD | DIV ENGINEER |
| | | | | PROJECT NO. 37642 | SECTION ### | |
| | | | | FHWA PROJECT NUMBER X-CM-XXXX-(PDX) | | |



Harper Houf Peterson Righellis Inc.
ENGINEERS • PLANNERS
LANDSCAPE ARCHITECTS • SURVEYORS
205 SE Spokane Street, Suite 206, Portland, OR 97202
phone: 503.221.1131 www.hhpz.com fax: 503.221.1171

APPROVALS:

DIVISION ENGINEER REG. PROF. ENGR. NO. 51538PE

CITY ENGINEER REG. PROF. ENGR. NO. 51538PE



SAM ADAMS
STEVE TOWNSEN, P.E.

COMMISSIONER
CITY ENGINEER

Temporary Construction Easement
100-110 N.E. ML KING JR. BLVD.

NE 3RD AVE - NE 14TH AVE (PORTLAND) SEC
E BURNSIDE - NE COUCH COUPLET

SHEET NO.

2

EXHIBIT 41

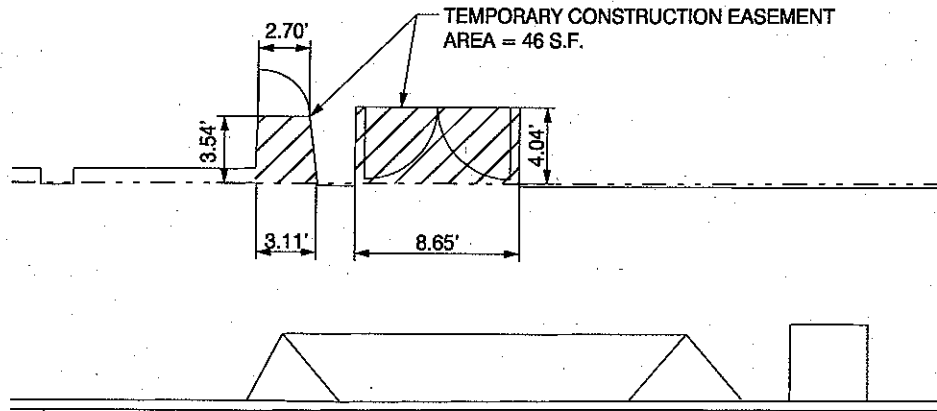

N.E. COUCH ST.

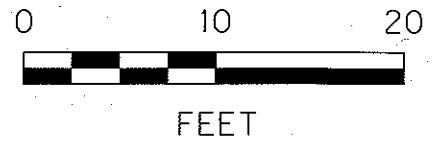

ROW FILE NO. 82
TAX LOT 1N1E35CB 4100

| | | | | |
|-----|------|---|---------------------------------|---------------|
| | | CHECKED BY <i>RDP</i> | DESIGNED BY <i>HHPR TEAM</i> | DATE APPROVED |
| | | | CAD BY <i>HHPR CAD</i> | DIV ENGINEER |
| | | PROJECT NO. 37642 | 1/2 SECTION #### | |
| | | FHWA PROJECT NUMBER <i>X-CM-XXXX-(PDX)</i> | | |
| NO. | DATE | DESCRIPTION | APPD. | |
| | | REVISION | | |



**Harper
Houf Peterson
Righellis Inc.**
ENGINEERS • PLANNERS
LANDSCAPE ARCHITECTS • SURVEYORS
205 SE Spokane Street, Suite 200, Portland, OR 97202
phone: 503.221.1131 www.hhpr.com fax: 503.221.1171

APPROVALS:

DIVISION ENGINEER _____ REG. PROF. ENGR. NO. 51538PE

CITY ENGINEER _____ REG. PROF. ENGR. NO. 51538PE

CITY OF PORTLAND
OFFICE OF
TRANSPORTATION

SAM ADAMS
STEVE TOWNSEN, P.E.

COMMISSIONER
CITY ENGINEER

**Temporary Construction Easement
106 N.E. GRAND AVE.**

NE 3RD AVE - NE 14TH AVE (PORTLAND) SEC
E BURNSIDE - NE COUCH COUPLET

SHEET NO.
1

EXHIBIT 42

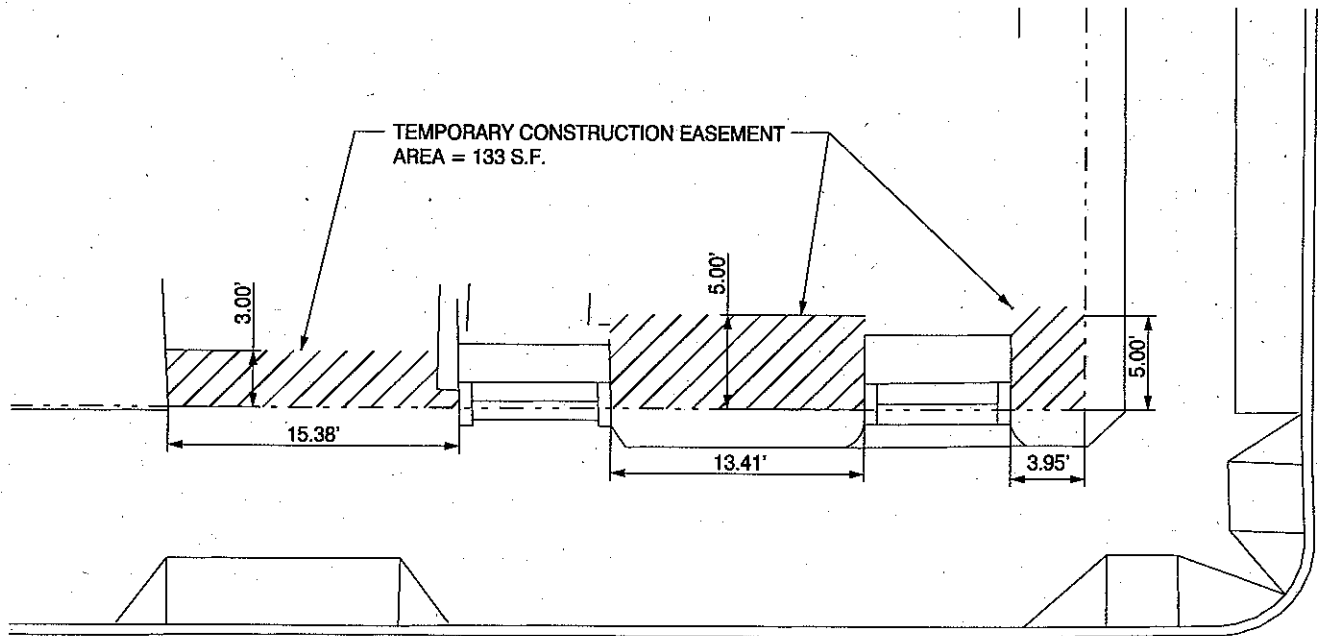

N.E. COUCH ST.

N.E. 6TH AVE.

ROW FILE NO. 83
TAX LOT 1N1E35CB 4200

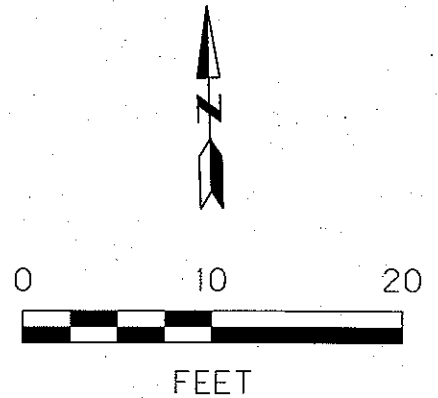

| | | | | | | |
|----------|------|-------------|-------|--|--------------------------|---------------|
| | | | | CHECKED BY RDP | DESIGNED BY HHPR TEAM | DATE APPROVED |
| | | | | | CAD BY HHPR CAD | DIV ENGINEER |
| | | | | PROJECT NO. 37642 | SECTION ### | |
| | | | | FHWA PROJECT NUMBER X-CM-XXXX-(PDX) | | |
| NO. | DATE | DESCRIPTION | APPD. | | | |
| REVISION | | | | | | |



Harper Houf Peterson Righellis Inc.
ENGINEERS • PLANNERS
LANDSCAPE ARCHITECTS • SURVEYORS
205 SE Spokane Street, Suite 200, Portland, OR 97202
phone: 503.221.1131 www.hhpr.com fax: 503.221.1171

APPROVALS:

DIVISION ENGINEER _____ REG. PROF. ENGR. NO. 51538PE

CITY ENGINEER _____ REG. PROF. ENGR. NO. 51538PE

CITY OF PORTLAND
OFFICE OF
TRANSPORTATION

SAM ADAMS
STEVE TOWNSEN, P.E.

COMMISSIONER
CITY ENGINEER

Temporary Construction Easement
521-537 N.E. COUCH ST.

NE 3RD AVE - NE 14TH AVE (PORTLAND) SEC
E BURNSIDE - NE COUCH COUPLET

SHEET NO.
1

EXHIBIT 43

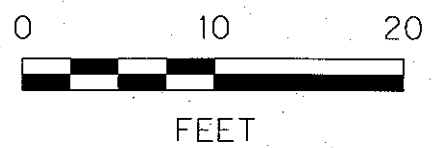
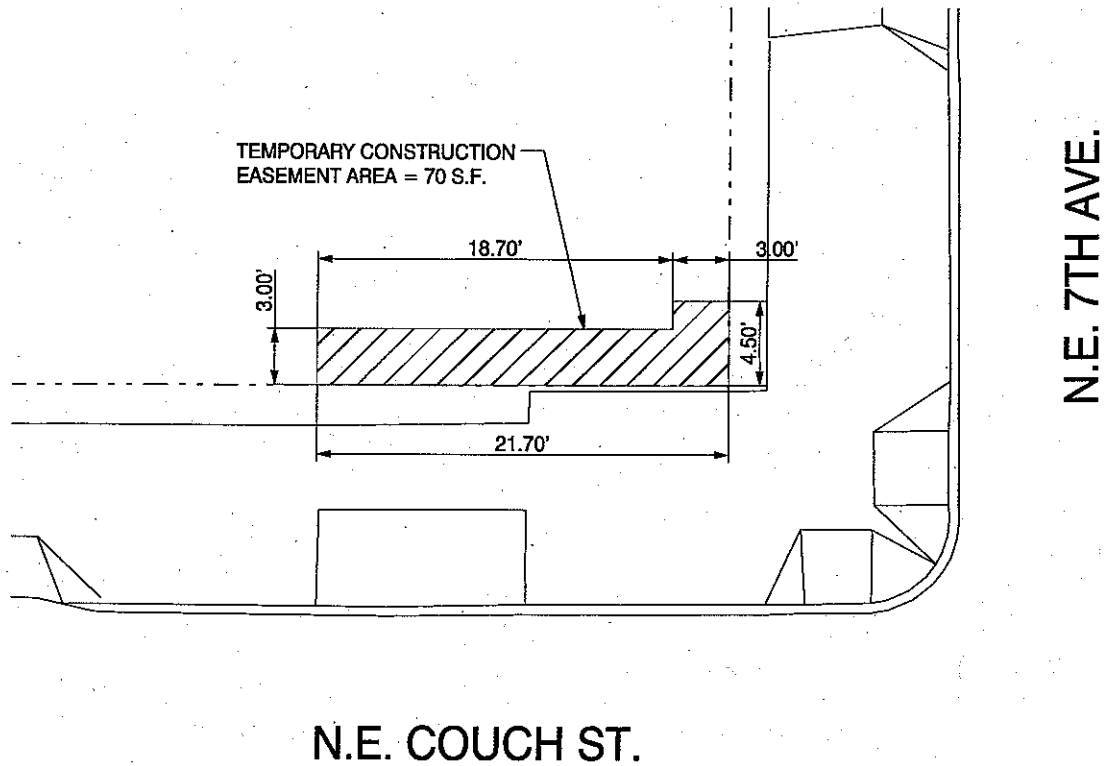

ROW FILE NO. 85
TAX LOT 1N1E35CB 4800

| | | | | |
|-----|------|---|---------------------------------|---------------|
| | | CHECKED BY <i>RDP</i> | DESIGNED BY <i>HHPR TEAM</i> | DATE APPROVED |
| | | | CAD BY <i>HHPR CAD</i> | DIV ENGINEER |
| | | PROJECT NO. 37642 | SECTION ### | |
| | | FHWA PROJECT NUMBER <i>X-CM-XXXX-(PDX)</i> | | |
| NO. | DATE | DESCRIPTION | APPD. | |
| | | REVISION | | |

| | | | |
|--|--|--|---|
| APPROVALS: DIVISION ENGINEER _____ REG. PROF. ENGR. NO. 51538PE CITY ENGINEER _____ REG. PROF. ENGR. NO. 51538PE | | CITY OF PORTLAND OFFICE OF TRANSPORTATION SAM ADAMS STEVE TOWNSEN, P.E. | Harper HHPR Houf Peterson Righellis Inc. ENGINEERS • PLANNERS LANDSCAPE ARCHITECTS • SURVEYORS 205 SE Spokane Street, Suite 200, Portland, OR 97202 phone: 503.221.1131 www.hhpr.com fax: 503.221.1171 |
| | | Temporary Construction Easement 123 N.E. 7TH ST. | |
| | | NE 3RD AVE - NE 14TH AVE (PORTLAND) SEC E BURNSIDE - NE COUCH COUPLET | SHEET NO. 1 |

EXHIBIT 44

N.E. 7TH AVE.

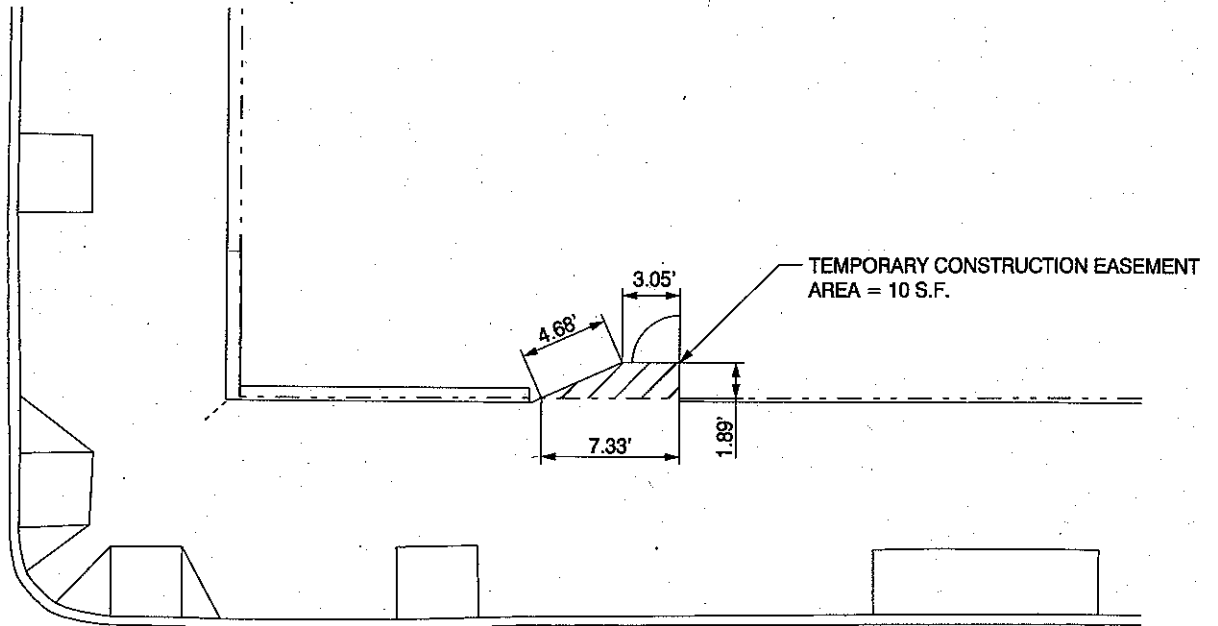

N.E. COUCH ST.

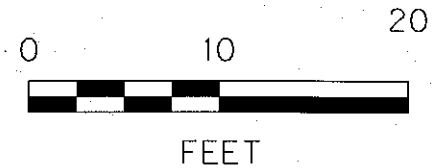

ROW FILE NO. 86
TAX LOT 1N1E35CB 5000

| | | | | | | |
|----------------------------|--|--|--|--|--------------------------|---------------|
| | | | | CHECKED BY RDP | DESIGNED BY HHPR TEAM | DATE APPROVED |
| | | | | | CAD BY HHPR CAD | DIV ENGINEER |
| | | | | PROJECT NO. 37642 | SECTION ### | |
| NO. DATE DESCRIPTION APPD. | | | | FHWA PROJECT NUMBER X-CM-XXXX-(PDX) | | |
| REVISION | | | | | | |



Harper Houf Peterson Righellis Inc.
ENGINEERS • PLANNERS
LANDSCAPE ARCHITECTS • SURVEYORS
205 SE Spokane Street, Suite 200, Portland, OR 97202
phone: 503.221.1131 www.hhpr.com fax: 503.221.1171

APPROVALS:

DIVISION ENGINEER _____ REG. PROF. ENGR. NO. 51538PE

CITY ENGINEER _____ REG. PROF. ENGR. NO. 51538PE

CITY OF PORTLAND OFFICE OF TRANSPORTATION

SAM ADAMS
STEVE TOWNSEN, P.E.

COMMISSIONER
CITY ENGINEER

Temporary Construction Easement
707 N.E. COUCH ST.

NE 3RD AVE - NE 14TH AVE (PORTLAND) SEC
E BURNSIDE - NE COUCH COUPLET

SHEET NO. **1**

EXHIBIT 45

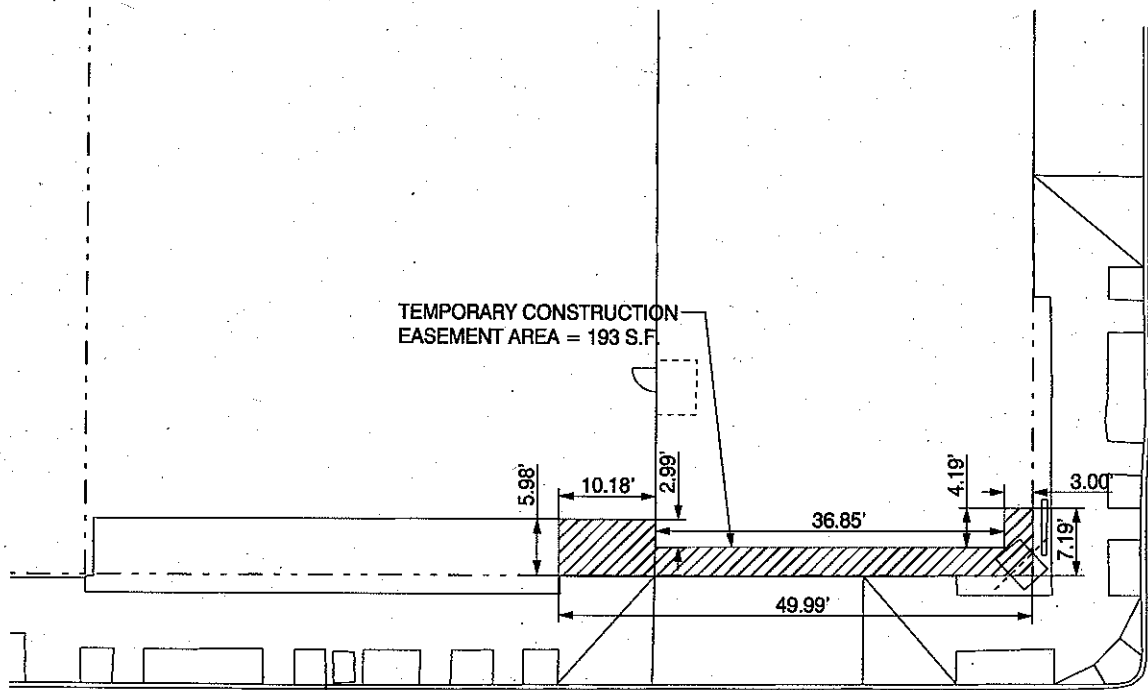

N.E. 8TH AVE.

N.E. COUCH ST.

ROW FILE NO. 87
TAX LOT 1N1E35CB 5100

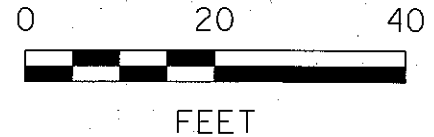

| | | | | | | |
|-----|------|-------------|-------|--|--------------------------|---------------|
| | | | | CHECKED BY RDP | DESIGNED BY HHPR TEAM | DATE APPROVED |
| | | | | | CAD BY HHPR CAD | DIV ENGINEER |
| | | | | PROJECT NO. 37642 | 1/4 SECTION #### | |
| NO. | DATE | DESCRIPTION | APPD. | FHWA PROJECT NUMBER X-CM-XXXX-(PDX) | | |
| | | REVISION | | | | |



Harper Houf Peterson Righellis Inc.
ENGINEERS • PLANNERS
LANDSCAPE ARCHITECTS • SURVEYORS
205 SE Spokane Street, Suite 200, Portland, OR 97202
phone: 503.221.1131 www.hhpr.com fax: 503.221.1171

APPROVALS:

| | |
|-------------------|------------------------------|
| DIVISION ENGINEER | REG. PROF. ENGR. NO. 51538PE |
| CITY ENGINEER | REG. PROF. ENGR. NO. 51538PE |

CITY OF PORTLAND OFFICE OF TRANSPORTATION

SAM ADAMS
STEVE TOWNSEN, P.E.

COMMISSIONER
CITY ENGINEER

Temporary Construction Easement
105 N.E. 8TH ST.

NE 3RD AVE - NE 14TH AVE (PORTLAND) SEC
E BURNSIDE - NE COUCH COUPLET

SHEET NO. **1**

EXHIBIT 46

N.E. 8TH AVE.

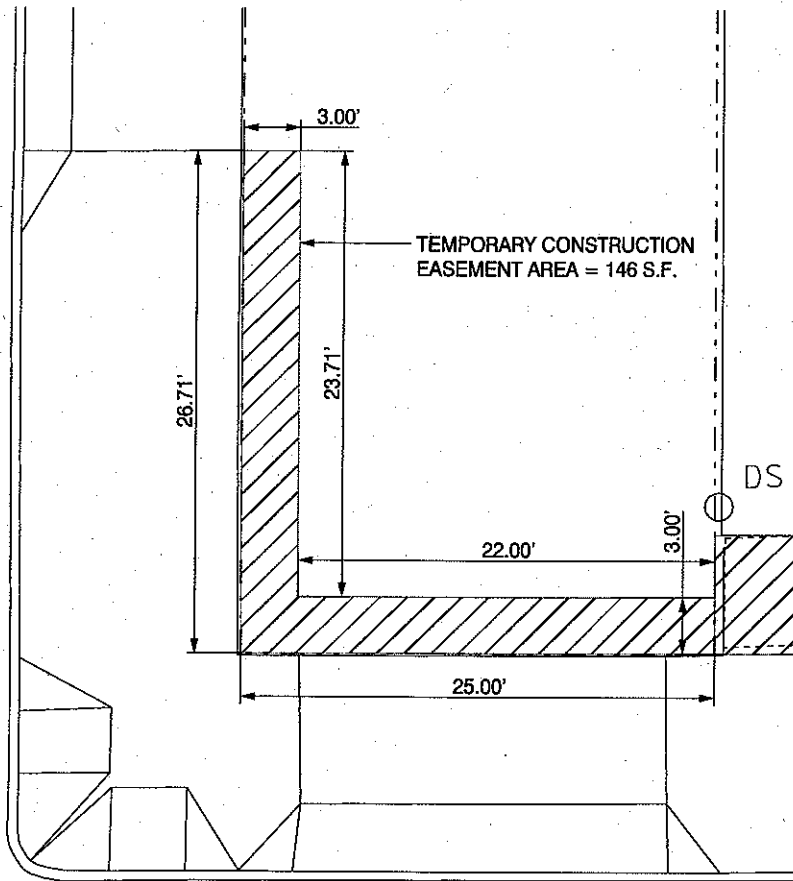

N.E. COUCH ST.



ROW FILE NO. 88
TAX LOT 1N1E35CB 5500

| | | | | |
|----------------------------|--|--|--------------------------|---------------|
| | | CHECKED BY RDP | DESIGNED BY HHPR TEAM | DATE APPROVED |
| | | | CAD BY HHPR CAD | DIV ENGINEER |
| | | PROJECT NO. 37642 | 1/2 SECTION #### | |
| NO. DATE DESCRIPTION APPD. | | FHWA PROJECT NUMBER X-CM-XXXX-(PDX) | | |
| REVISION | | | | |



Harper Houf Peterson Righellis Inc.
ENGINEERS • PLANNERS
LANDSCAPE ARCHITECTS • SURVEYORS
205 SE Spokane Street, Suite 200, Portland, OR 97202
phone: 503.221.1131 www.hhpr.com fax: 503.221.1171

APPROVALS:

| | |
|-------------------|------------------------------|
| DIVISION ENGINEER | REG. PROF. ENGR. NO. 51538PE |
| CITY ENGINEER | REG. PROF. ENGR. NO. 51538PE |

CITY OF PORTLAND OFFICE OF TRANSPORTATION
SAM ADAMS
STEVE TOWNSEN, P.E.
COMMISSIONER
CITY ENGINEER

**Temporary Construction Easement
807 N.E. COUCH STREET**
NE 3RD AVE - NE 14TH AVE (PORTLAND) SEC
E BURNSIDE - NE COUCH COUPLET

SHEET NO.
1

EXHIBIT 47

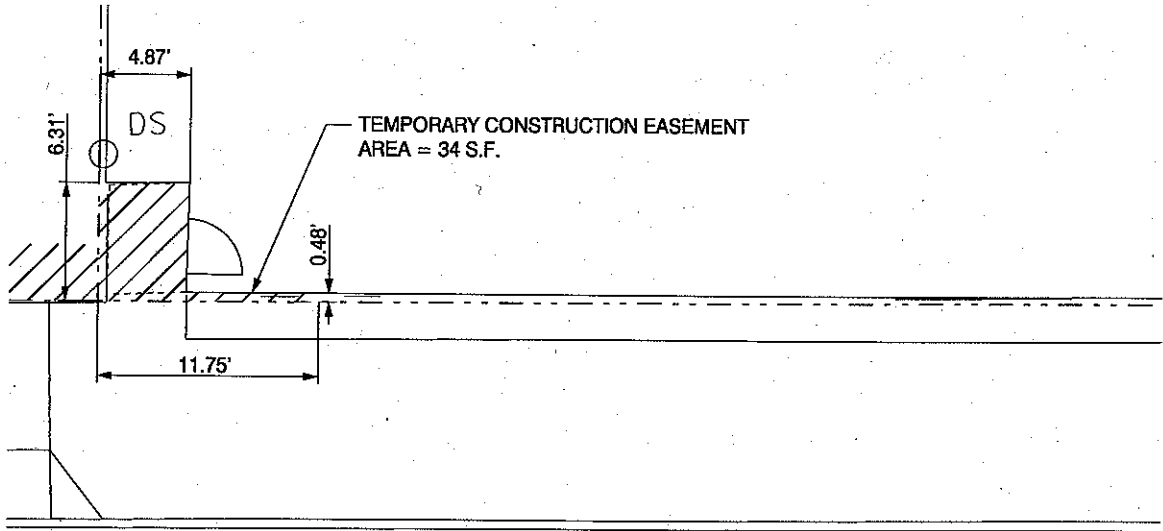

N.E. COUCH ST.

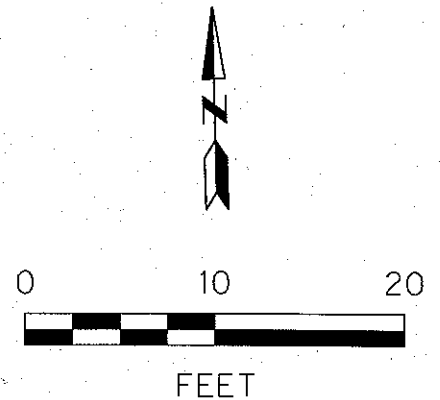

ROW FILE NO. 89
TAX LOT 1N1E35CB 5600

| | | | | | | |
|-----|------|-------------|-------|---|---------------------------------|---------------|
| | | | | CHECKED BY <i>RDP</i> | DESIGNED BY <i>HHPR TEAM</i> | DATE APPROVED |
| | | | | | CAD BY <i>HHPR CAD</i> | DIV ENGINEER |
| | | | | PROJECT NO. <i>37642</i> | SECTION <i>####</i> | |
| NO. | DATE | DESCRIPTION | APPD. | FHWA PROJECT NUMBER <i>X-CM-XXXX-(PDX)</i> | | |
| | | REVISION | | | | |



Harper Houf Peterson Righellis Inc.
ENGINEERS • PLANNERS
LANDSCAPE ARCHITECTS • SURVEYORS
205 SE Spokane Street, Suite 200, Portland, OR 97202
phone: 503.221.1131 www.hhpr.com fax: 503.221.1171

APPROVALS:

DIVISION ENGINEER _____ REG. PROF. ENGR. NO. 51538PE
CITY ENGINEER _____ REG. PROF. ENGR. NO. 51538PE

CITY OF PORTLAND
OFFICE OF
TRANSPORTATION
SAM ADAMS
STEVE TOWNSEN, P.E.
COMMISSIONER
CITY ENGINEER

Temporary Construction Easement
807 N.E. COUCH ST.

NE 3RD AVE - NE 14TH AVE (PORTLAND) SEC
E BURNSIDE - NE COUCH COUPLET

SHEET NO.
1

EXHIBIT 48

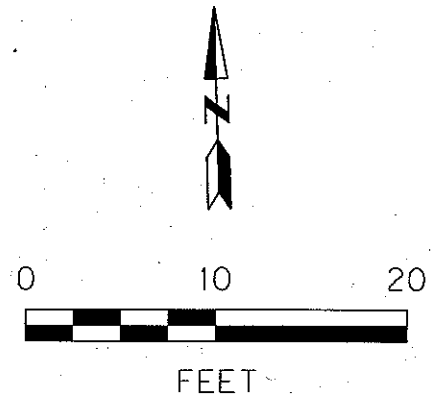
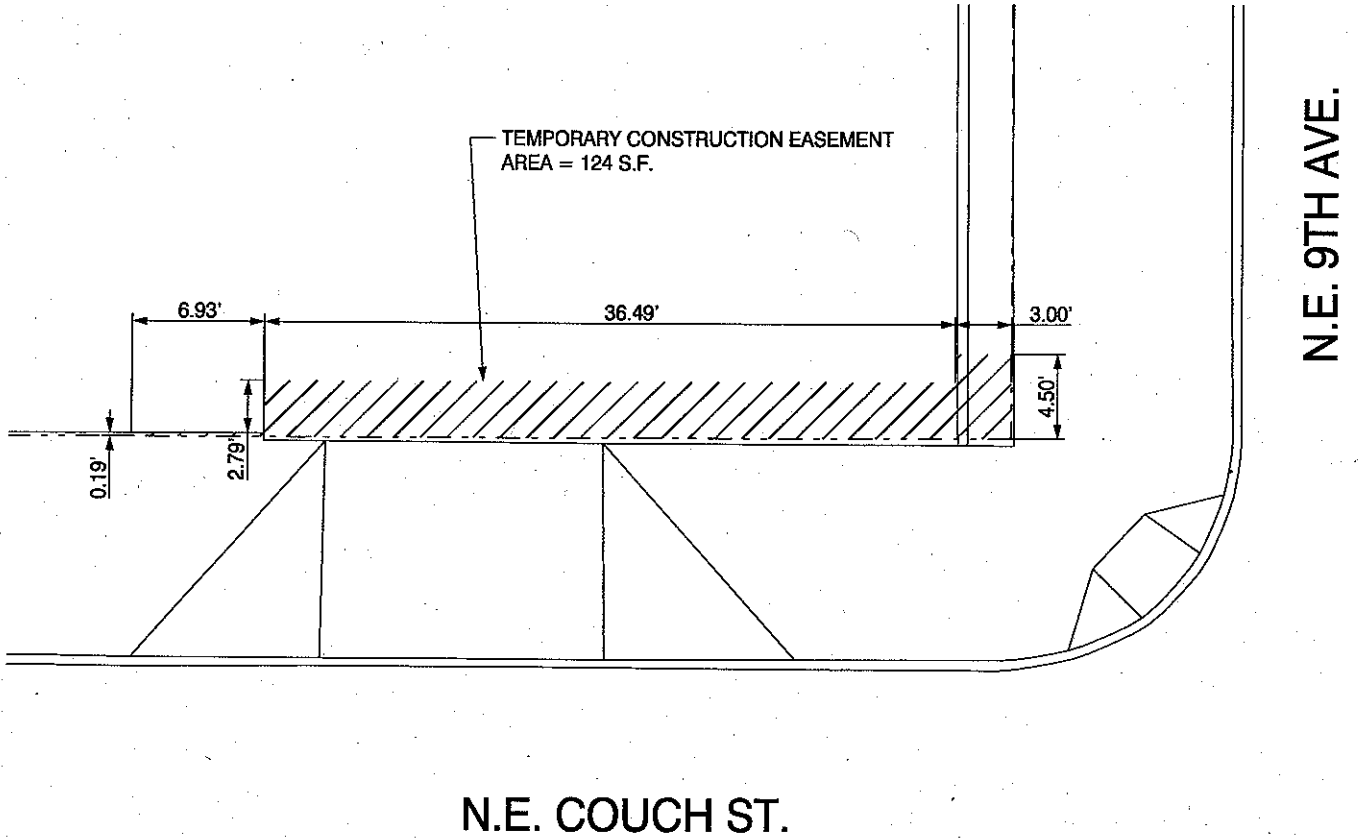

ROW FILE NO. 90
TAX LOT 1N1E35CB 6300

| | | | | | | |
|-----|------|-------------|-------|--|--------------------------|---------------|
| | | | | CHECKED BY RDP | DESIGNED BY HHPR TEAM | DATE APPROVED |
| | | | | | CAD BY HHPR CAD | DIV ENGINEER |
| | | | | PROJECT NO. 37642 | 1/4 SECTION #### | |
| | | | | FHWA PROJECT NUMBER X-CM-XXXX-(PDX) | | |
| NO. | DATE | DESCRIPTION | APPD. | REVISION | | |



Harper Houf Peterson Righellis Inc.
ENGINEERS • PLANNERS
LANDSCAPE ARCHITECTS • SURVEYORS
205 SE Spokane Street, Suite 200, Portland, OR 97202
phone: 503.221.1131 www.hhpr.com fax: 503.221.1171

APPROVALS:

DIVISION ENGINEER _____ REG. PROF. ENGR. NO. 5153BPE

CITY ENGINEER _____ REG. PROF. ENGR. NO. 5153BPE

CITY OF PORTLAND
OFFICE OF
TRANSPORTATION

SAM ADAMS
STEVE TOWNSEN, P.E.

COMMISSIONER
CITY ENGINEER

Temporary Construction Easement
105 N.E. 9TH ST.

NE 3RD AVE - NE 14TH AVE (PORTLAND) SEC
E BURNSIDE - NE COUCH COUPLER

SHEET NO. **1**

EXHIBIT 49

N.E. 9TH AVE.

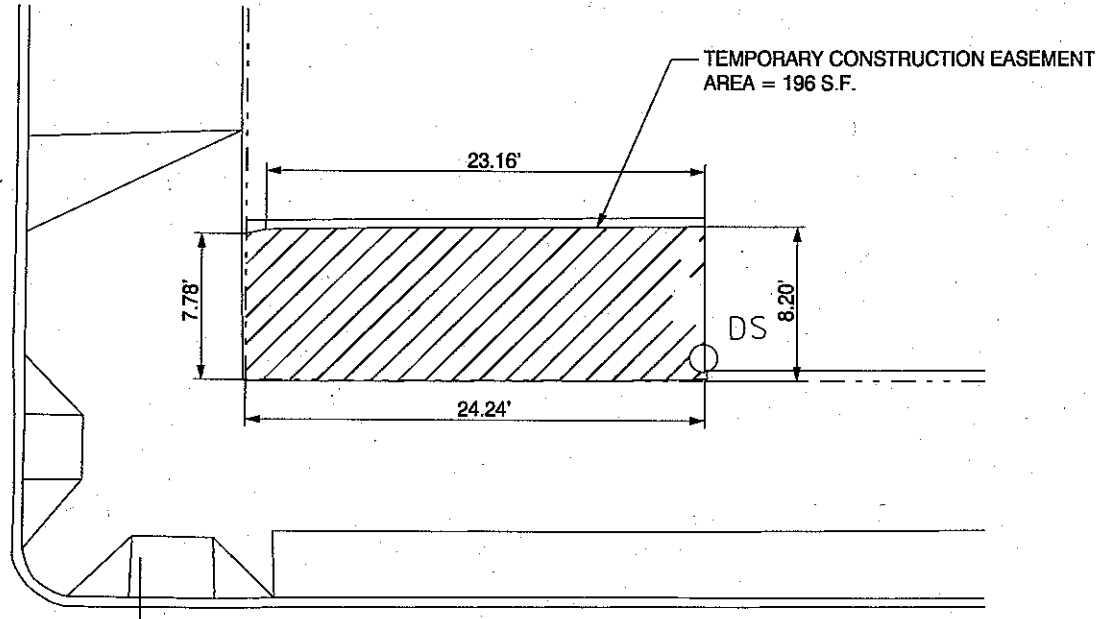

N.E. COUCH ST.

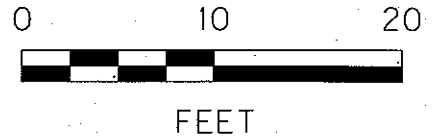

ROW FILE NO. 91
TAX LOT 1N1E35CA 2900

| | | | | |
|-----|------|--|--------------------------|---------------|
| | | CHECKED BY RDP | DESIGNED BY HHPR TEAM | DATE APPROVED |
| | | | CAD BY HHPR CAD | DIV ENGINEER |
| | | PROJECT NO. 37642 | 1/4 SECTION #### | |
| | | FHWA PROJECT NUMBER X-CM-XXXX-(PDX) | | |
| NO. | DATE | DESCRIPTION | APPD. | |
| | | REVISION | | |



Harper Houf Peterson Righellis Inc.
ENGINEERS • PLANNERS
LANDSCAPE ARCHITECTS • SURVEYORS
205 SE Spokane Street, Suite 200, Portland, OR 97202
phone: 503.221.1131 www.hhp.com fax: 503.221.1171

APPROVALS:

DIVISION ENGINEER _____ REG. PROF. ENGR. NO. 51538PE

CITY ENGINEER _____ REG. PROF. ENGR. NO. 51538PE

CITY OF PORTLAND
OFFICE OF
TRANSPORTATION

SAM ADAMS
STEVE TOWNSEN, P.E.

COMMISSIONER
CITY ENGINEER

Temporary Construction Easement
120 N.E. 9TH AVE.

NE 3RD AVE - NE 14TH AVE (PORTLAND) SEC
E BURNSIDE - NE COUCH COUPLET

SHEET NO. **1**

EXHIBIT 50

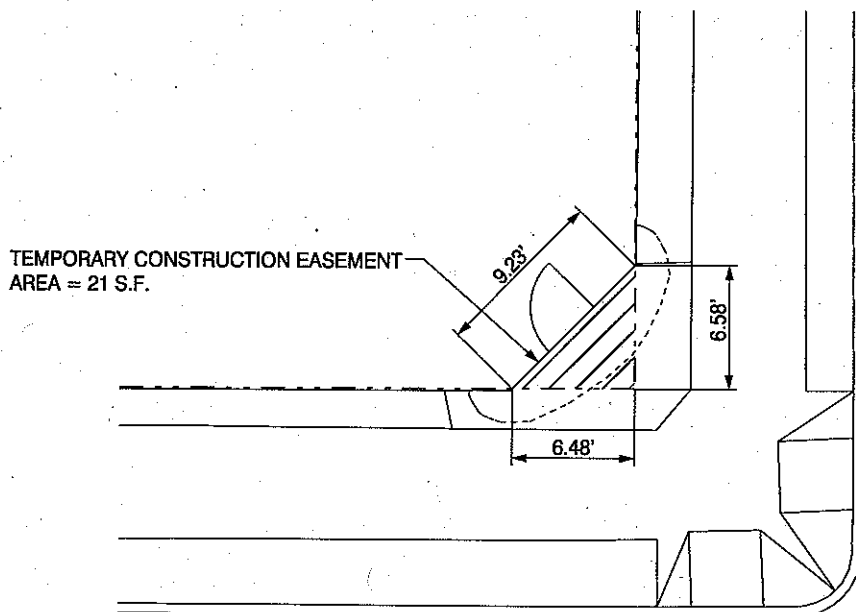

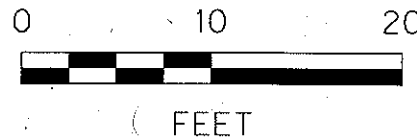

N.E. 10TH AVE.

N.E. COUCH ST.



ROW FILE NO. 93
TAX LOT 1N1E35CA 3100

| | | | | | | |
|-----|------|----------------------|--------------------------|--|---|--|
| | | CHECKED BY RDP | DESIGNED BY HHPR TEAM | DATE APPROVED |  |  Harper Houf Peterson Righellis Inc. <small>ENGINEERS • PLANNERS LANDSCAPE ARCHITECTS • SURVEYORS 205 SE Spokane Street, Suite 200, Portland, OR 97202 phone: 503.221.1131 www.hhpr.com fax: 503.221.1171</small> |
| | | | CAD BY HHPR CAD | DEV ENGINEER | | |
| | | PROJECT NO. 37642 | SECTION #### | | | |
| NO. | DATE | DESCRIPTION | APPD. | FHWA PROJECT NUMBER X-CM-XXXX-(PDX) | | |
| | | REVISION | | | | |

APPROVALS:

| | |
|-------------------|------------------------------|
| DIVISION ENGINEER | REC. PROF. ENGR. NO. 51538PE |
| CITY ENGINEER | REC. PROF. ENGR. NO. 51538PE |



**CITY OF
PORTLAND
OFFICE OF
TRANSPORTATION**

SAM ADAMS
STEVE TOWNSEN, P.E.

COMMISSIONER
CITY ENGINEER

**Temporary Construction Easement
935 N.E. COUCH ST.**

NE 3RD AVE - NE 14TH AVE (PORTLAND) SEC
E BURNSIDE - NE COUCH COUPLET

SHEET NO.
1

EXHIBIT 51

N.E. 10TH AVE.

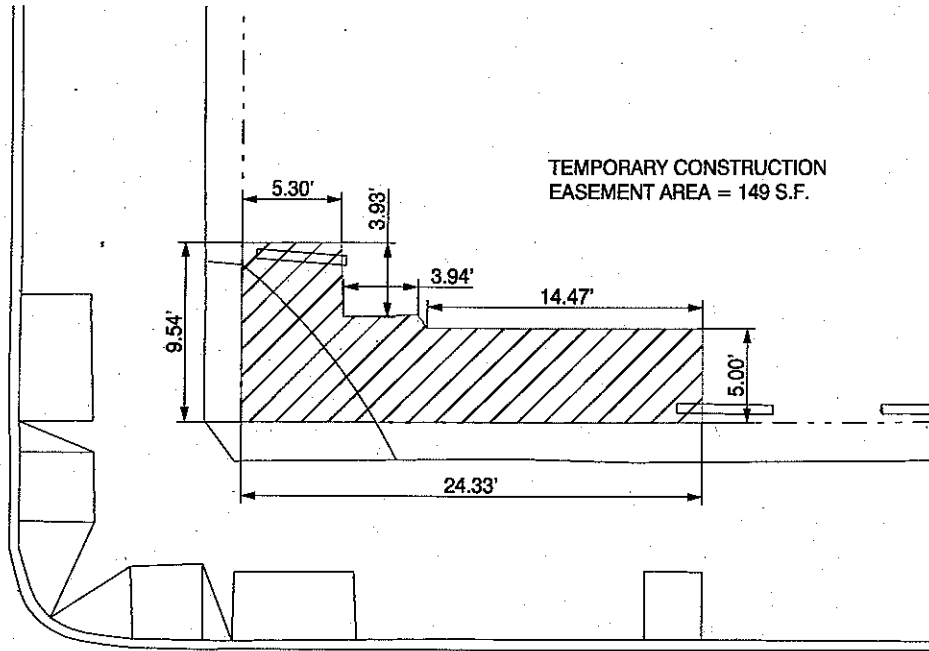

N.E. COUCH ST.

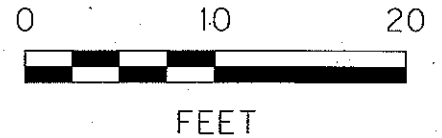

ROW FILE NO. 94
TAX LOT 1N1E35CA 3200

| | | | | | | |
|-----|------|-------------|-------|---|---------------------------------|---------------|
| | | | | CHECKED BY <i>RDP</i> | DESIGNED BY <i>HHPR TEAM</i> | DATE APPROVED |
| | | | | | CAD BY <i>HHPR CAD</i> | DIV ENGINEER |
| | | | | PROJECT NO. 37642 | 1/4 SECTION ### | |
| NO. | DATE | DESCRIPTION | APPD. | FHWA PROJECT NUMBER <i>X-CM-XXXX-(PDX)</i> | | |
| | | REVISION | | | | |



Harper Houf Peterson Righellis Inc.
ENGINEERS • PLANNERS
LANDSCAPE ARCHITECTS • SURVEYORS
205 SE Spokane Street, Suite 200, Portland, OR 97202
phone: 503.221.1131 www.hhpr.com fax: 503.221.1171

APPROVALS:

DIVISION ENGINEER _____ REG. PROF. ENGR. NO. 51538PE

CITY ENGINEER _____ REG. PROF. ENGR. NO. 51538PE

CITY OF PORTLAND OFFICE OF TRANSPORTATION

SAM ADAMS
STEVE TOWNSEN, P.E.

COMMISSIONER
CITY ENGINEER

Temporary Construction Easement
1030 N.E. COUCH ST.

NE 3RD AVE - NE 14TH AVE (PORTLAND) SEC
E BURNSIDE - NE COUCH COUPLET

SHEET NO. **1**

EXHIBIT 52

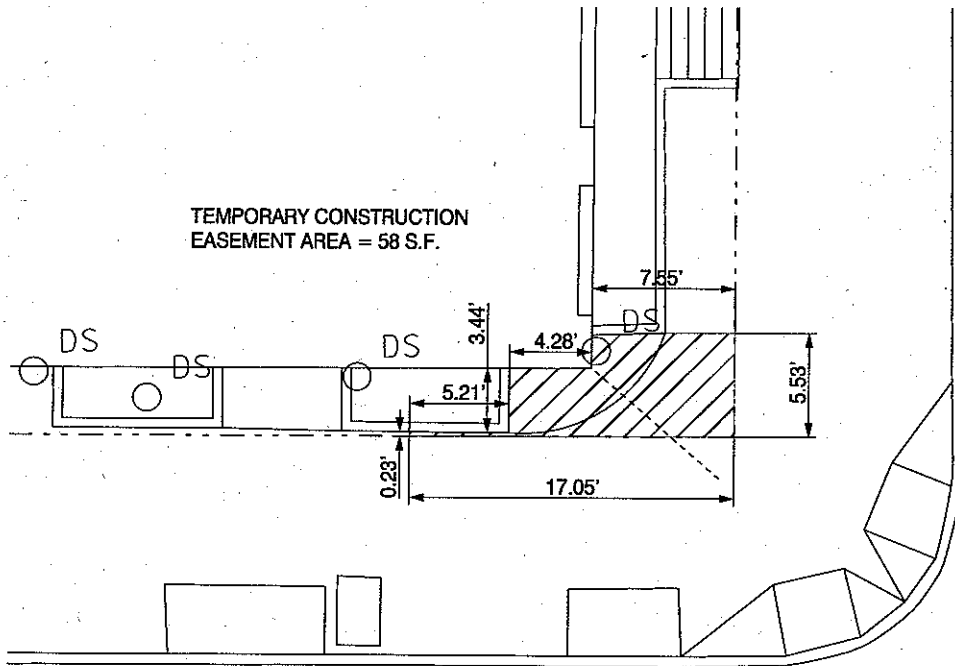

N.E. 11TH AVE.

N.E. COUCH ST.

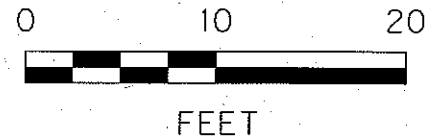

ROW FILE NO. 95
TAX LOT 1N1E35CA 3400

| | | | | |
|----------------------------|--|--|--------------------------|---------------|
| | | CHECKED BY RDP | DESIGNED BY HHPR TEAM | DATE APPROVED |
| | | | CAD BY HHPR CAD | DIV ENGINEER |
| | | PROJECT NO. 37642 | SECTION #### | |
| NO. DATE DESCRIPTION APPD. | | FHWA PROJECT NUMBER X-CM-XXXX-(PDX) | | |
| REVISION | | | | |



Harper Houf Peterson Righellis Inc.
ENGINEERS • PLANNERS
LANDSCAPE ARCHITECTS • SURVEYORS
205 SE Spokane Street, Suite 200, Portland, OR 97202
phone: 503.221.1131 www.hhpr.com fax: 503.221.1171

APPROVALS:

DIVISION ENGINEER _____ REG. PROF. ENGR. NO. 51538PE

CITY ENGINEER _____ REG. PROF. ENGR. NO. 51538PE

CITY OF PORTLAND
OFFICE OF
TRANSPORTATION

SAM ADAMS
STEVE TOWNSEN, P.E.

COMMISSIONER
CITY ENGINEER

Temporary Construction Easement
111 N.E. 11TH ST.

NE 3RD AVE - NE 14TH AVE (PORTLAND) SEC
E BURNSIDE - NE COUCH COUPLER

SHEET NO.
1

EXHIBIT 53

N.E. 12TH AVE.

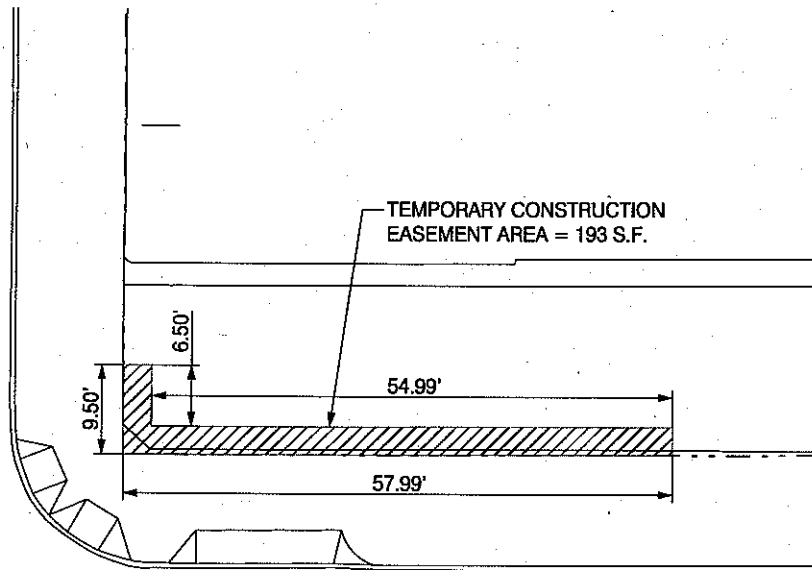

N.E. COUCH ST.

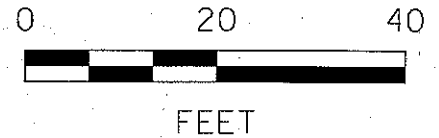

ROW FILE NO. 99
TAX LOT 1N1E35CA 4500

| | | | | | | | |
|-----|------|--|--------------------------|---------------|---|---|--|
| | | CHECKED BY RDP | DESIGNED BY HHPR TEAM | DATE APPROVED |  | Harper HHPR Houf Peterson Righellis Inc. <small>ENGINEERS • PLANNERS LANDSCAPE ARCHITECTS • SURVEYORS 205 SE Spokane Street, Suite 200, Portland, OR 97202 phone: 503.221.1131 www.hhpr.com fax: 503.221.1171</small> | |
| | | | CAD BY HHPR CAD | DIY ENGINEER | | | |
| | | PROJECT NO. 37642 | 1/SECTION ### | | | | |
| | | FHWA PROJECT NUMBER X-CM-XXXX-(PDX) | | | | | |
| NO. | DATE | DESCRIPTION | APPD. | REVISION | | | |

APPROVALS:

| | |
|-------------------|------------------------------|
| DIVISION ENGINEER | REG. PROF. ENGR. NO. 51538PE |
| CITY ENGINEER | REG. PROF. ENGR. NO. 51538PE |



**CITY OF
PORTLAND
OFFICE OF
TRANSPORTATION**

SAM ADAMS
STEVE TOWNSEN, P.E.

COMMISSIONER
CITY ENGINEER

**Temporary Construction Easement
1221 N.E. COUCH ST.**

NE 3RD AVE - NE 14TH AVE (PORTLAND) SEC
E BURNSIDE - NE COUCH COUPLER

SHEET NO. **1**

EXHIBIT 54

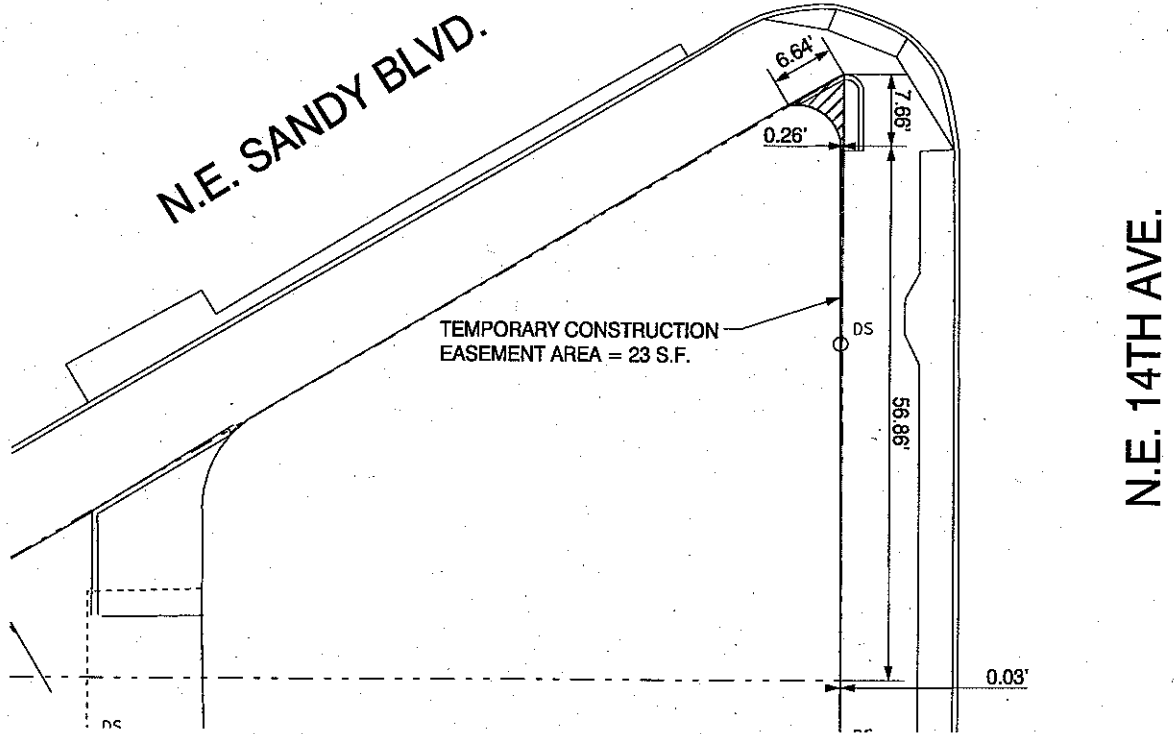

ROW FILE NO. 109
TAX LOT 1N1E35CA 4800

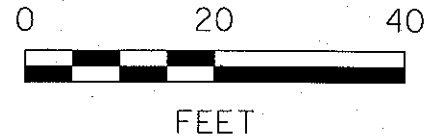

| NO. | DATE | DESCRIPTION | APPD. | PROJECT NO. | SECTION | FIHWA PROJECT NUMBER |
|-----|------|-------------|-------|-------------|---------|----------------------|
| | | | | 37642 | #### | X-CM-XXXX-(PDX) |
| | | REVISION | | | | |



Harper Houf Peterson Righellis Inc.
ENGINEERS + PLANNERS
LANDSCAPE ARCHITECTS + SURVEYORS
205 SE Spokane Street, Suite 200, Portland, OR 97202
phone: 503.221.1131 www.hhpr.com fax: 503.221.1171

APPROVALS:

DIVISION ENGINEER REG. PROF. ENGR. NO. 51538PE
CITY ENGINEER REG. PROF. ENGR. NO. 51538PE

CITY OF PORTLAND
OFFICE OF TRANSPORTATION
SAM ADAMS
STEVE TOWNSEN, P.E. COMMISSIONER
CITY ENGINEER

Temporary Construction Easement
1338 N.E. SANDY BLVD.

NE 3RD AVE - NE 14TH AVE (PORTLAND) SEC
E BURNSIDE - NE COUCH COUPLET

SHEET NO.
1

EXHIBIT 55

E. COUCH ST.

N.E. M.L. KING JR. BLVD.

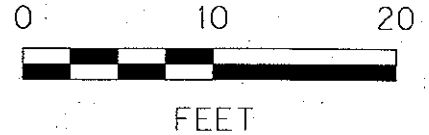
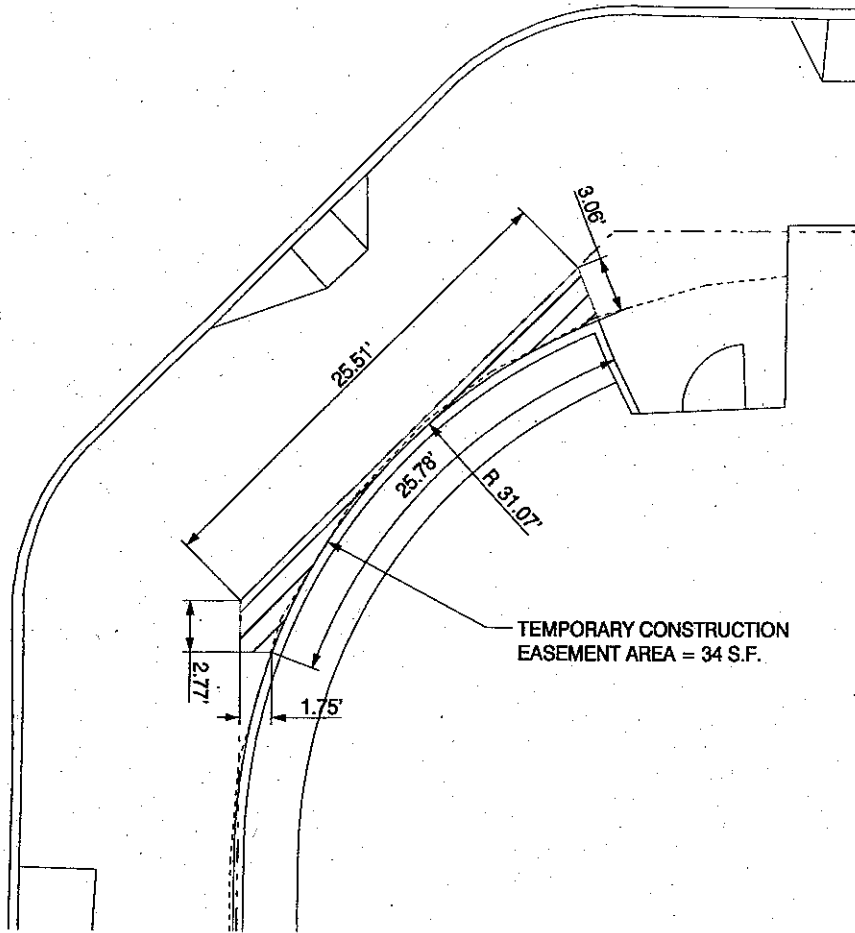

ROW FILE NO. 57
TAX LOT 1N1E35CB 8800

| | | | | | | |
|----------|------|-------------|-------|--|---------------------------------|---------------|
| | | | | CHECKED BY RDP | DESIGNED BY HHPR TEAM | DATE APPROVED |
| | | | | | CAD BY HHPR CAD | DIV. ENGINEER |
| | | | | PROJECT NO. 37642 | SECTION ### | |
| NO. | DATE | DESCRIPTION | APPD. | FHWA PROJECT NUMBER X-CM-XXX-(PDX) | | |
| REVISION | | | | | | |



Harper Houf Peterson Righellis Inc.
ENGINEERS • PLANNERS
LANDSCAPE ARCHITECTS • SURVEYORS
205 SE Spokane Street, Suite 200, Portland, OR 97202
phone: 503.221.1131 www.hhpr.com fax: 503.221.1171

APPROVALS:

| | |
|-------------------|------------------------------|
| DIVISION ENGINEER | REG. PROF. ENGR. NO. 51538PE |
| CITY ENGINEER | REG. PROF. ENGR. NO. 51538PE |

CITY OF PORTLAND
OFFICE OF
TRANSPORTATION

SAM ADAMS
STEVE TOWNSEN, P.E.

COMMISSIONER
CITY ENGINEER

Temporary Construction Easement
30 N.E. M.L. KING BLVD.

NE 3RD AVE - NE 14TH AVE (PORTLAND) SEC
E BURNSIDE - NE COUCH COUPLET

SHEET NO. **1**