

ACCEPTANCE

RECEIVED
MAR 10 10 18 AM 1982
GEORGE YERKOVICH, AUDITOR
CITY OF PORTLAND, ORE.

Portland, Oregon, February 11, 1982

GEORGE YERKOVICH
Auditor of the City of Portland,
Room 202, City Hall
Portland, Oregon 97204

Dear Sir:

This is to advise the City of Portland, Oregon, that I hereby accept the terms and provisions of Ordinance No. 152839, passed by Council February 11, 1982, granting a revocable permit to Columbia Bus Service to install a 12,000 gallon liquid propane storage tank on the property at the Columbia Bus Service Storage and Maintenance lot at 10706 SW Capital Highway, under certain conditions,

and in consideration of the benefits to be received thereunder by me I hereby agree to abide by and perform each and all of the terms and provisions thereof applicable to me.

Very truly yours,

(CORPORATE SEAL)

COLUMBIA BUS SERVICE

[Signature] President

10706 SW Capitol Hwy., Portland, OR 97219

Address

APPROVED AS TO FORM
Approved as to form:

Christopher P. Thomas

CITY ATTORNEY
City Attorney

*When an acceptance is required from a firm or corporation the Acceptance must be signed by an officer of the firm or corporation stating his or her official title, and corporations must affix the corporate seal.

Columbia Bus Service

152839

10706 S.W. Capital Hwy. — Portland, Oregon 97219 — (503) 245-3179

Mildred Schwab
City Commissioner
City of Portland
1220 S.W. 5th
Portland, Or. 97204

January 14, 1982

Dear Ms. Schwab,

We at Columbia Bus Service respectfully request the City's approval to install a 12,000 gallon liquid propane storage tank at our facility at 10706 S.W. Capitol Hwy., Portland, 97219.

Application has been made to the State Fire Marshall's office for permission to place the tank on site. Verne Duncan, State Superintendent of Public Instruction, has granted his approval to convert our school buses to liquid propane carburetion.

Columbia Bus Service contracts with the Tigard School District to transport approximately 4200 school children daily. Approval to convert our buses to propane has been granted by the Board of Directors of the Tigard School District. We solicited their approval for several reasons. 1) The cost difference between gasoline and propane would warrant savings to the School District's Transportation program, 2) Exhaust emissions would be reduced by over 50%, 3) Prolonged equipment life, and last, but not least, 4) The safety of the students aboard the buses would not be compromised.

Propane fuel systems are inherently safer due to the fact that they operate under a sealed system. We ask for your approval to place the storage tank on our property for these reasons.

Per conversations with Matt Greenslade, Special Hazards Inspector for the City of Portland, we are submitting sketches of our facility showing placement of the tank on our property, a letter from the property owner next door, and detailed drawings of the tank and the dispensing devices.



EDUCATIONAL & RECREATIONAL SERVICES, INC.

a subsidiary of ARA Services, Inc.

Petrolanc, a private corporation, will be installing the tank and converting the school buses with state certified professionals.

We are forwarding copies of the enclosed material to Matt Greenslade along with a check for \$100.00 to be kept as a deposit.

We at Columbia Bus Service appreciate your cooperation in this matter, and hope that if you have any questions, you'll feel free to give us a call.

Sincerely,

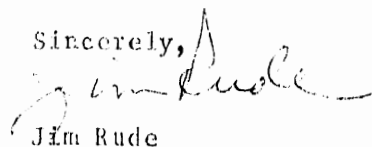

Jim Rude

Terminal Manager

cc: Matt Greenslade
Jan Hiserole
Alan Sharrah
Dave Daly
Howard Hicks

Monday January 11th, 1982

Jan J Fourier
Rt 2 Box 47
McMinnville, Oregon 97128

Columbia Bus Service
Attn: Jim Rude
10706 SW Capitol Hwy
Portland, Oregon 97219

RE: Proposed Propane storage tank

Dear Jim:

Please let this letter serve as positive confirmation of our discussion concerning your plans to place a propane storage tank at the Capitol Highway facility.

Assuming that the placement of the tank will meet with all current city and county regulations, and that any liability caused by the placement of the tank is taken care of, we would have no objections to its placement.

I have enclosed a copy of a plat map for your convenience showing the property lines of the Capitol Highway property.

Please keep me advised of your progress on the above matter. Should further information be needed, please let me know.

Sincerely,

Jan J Fourier

Columbia Bus Service

10706 S.W. Capital Hwy. - Portland, Oregon 97219 - (503) 245-3179

152839

Suzanne Vara
Bureau of Buildings
Room 111
1220 S.W. 5th Ave.
Portland, Or. 97204

January 25, 1982

Dear Ms. Vara

As per our conversation, January 22nd, we understand that to replace our gasoline pumping facility with a liquid propane storage and pumping facility, as a non-conforming use, it will not be necessary to obtain a variance on the present zoning.

If I can be of further assistance in this matter, please let me know.

Sincerely,

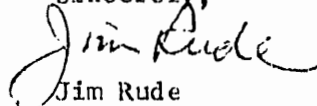

Jim Rude
Terminal Manager

cc: Matt Greenslade
Alan Sharrah



OFFICE of FIRE MARSHAL

152839

FIRE PREVENTION DIVISION CITY OF PORTLAND

From: Matt Greenslade, Fire Marshal's Office, 139/304 Date: Jan. 19, 1982
To: City Treasurer's Office, 131/204
Subject: Deposit Columbia Bus Service Check to Trust Fund

Columbia Bus Service check for \$100.00 to be placed in Trust Fund pending issuance of Council Permit to install a 12,000 gallon liquid propane storage tank at 10706 S. W. Capitol Highway, Portland, Oregon 97219.

COLUMBIA BUS SERVICE

PETTY CASH ACCOUNT
6755 N.E. COLUMBIA BLVD.
PORTLAND, OREGON 97218
284-6466

24-12/1230 100

No 4341

January 13, 1982 19

PAY TO THE ORDER OF City of Portland \$ 100.00

ONE HUNDRED DOLLARS DOLLARS

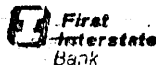

First Interstate Bank
of Oregon N.A.
Gateway Branch
P.O. Box 20967
Portland, Oregon 97220

Alay G. Shaver

⑈004341⑈ ⑆123000123⑆100 012175 4⑈

DETACH AND RETAIN THIS STATEMENT

THE ATTACHED CHECK IS IN PAYMENT OF ITEMS DESCRIBED BELOW • IF NOT CORRECT PLEASE NOTIFY US PROMPTLY • NO RECEIPT DESIRED

Deposit for city of Portland approval of Propane tank placement.

CBS - Columbia Bus Serv.

SBS - Columbia Bus Services

10706 S.W. Cap. Hwy, Portland, Oregon 97229

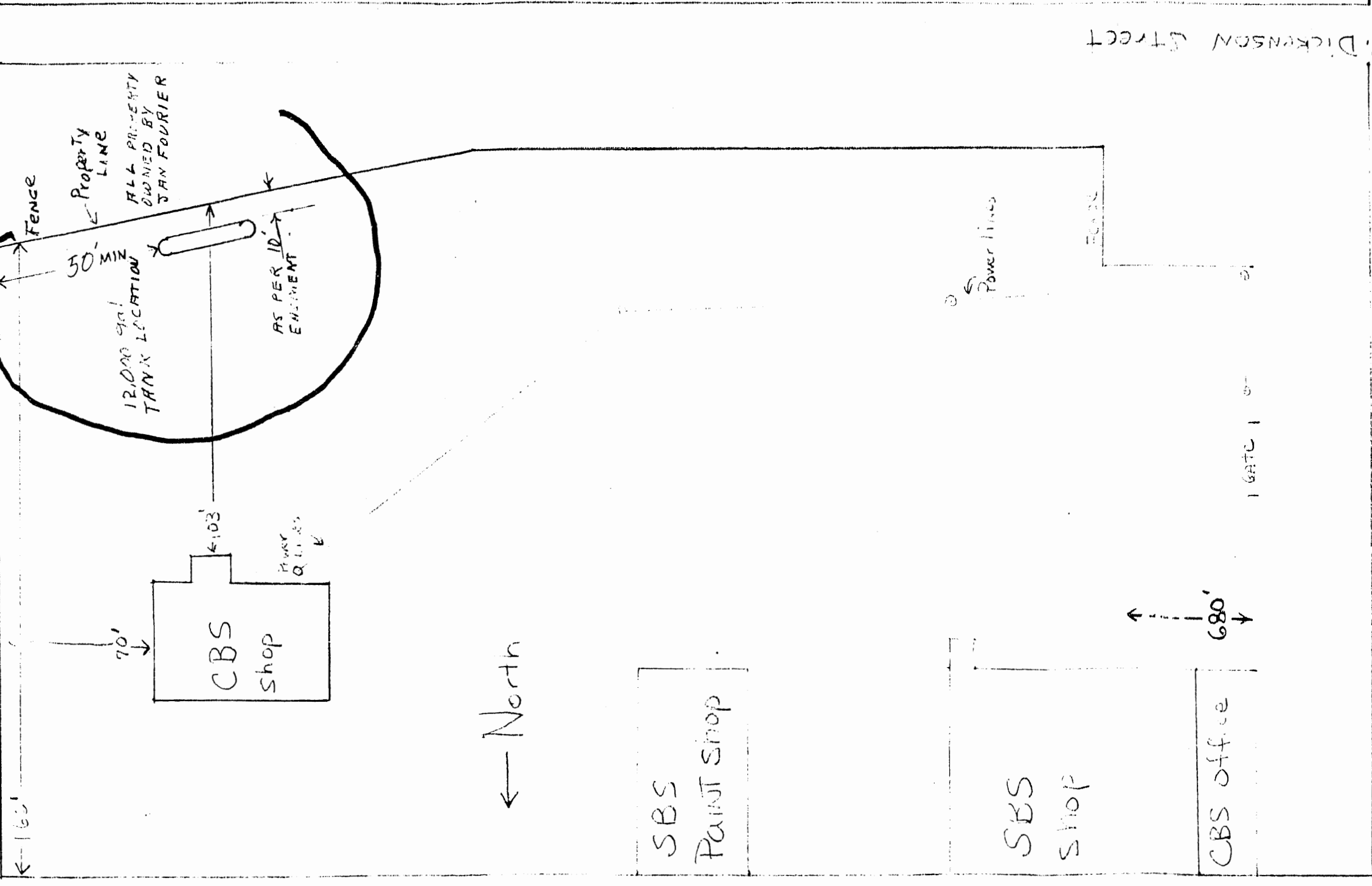

← North

G.W. Dickerson Street

S.W. Cap. Hwy

PIER PLAN

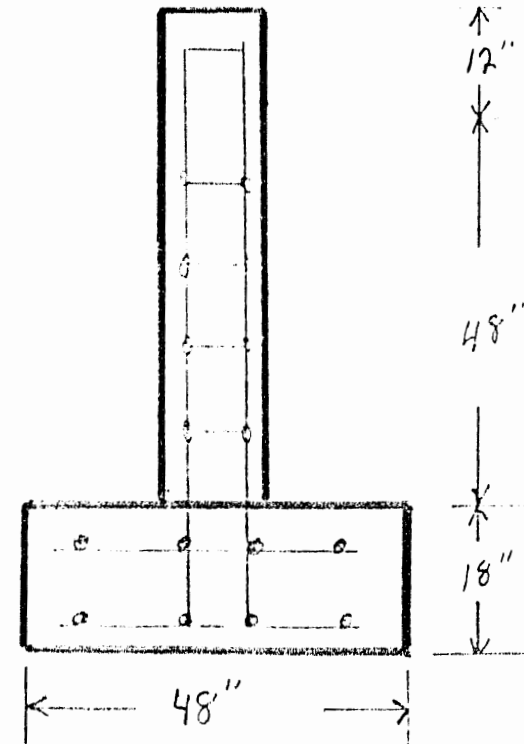
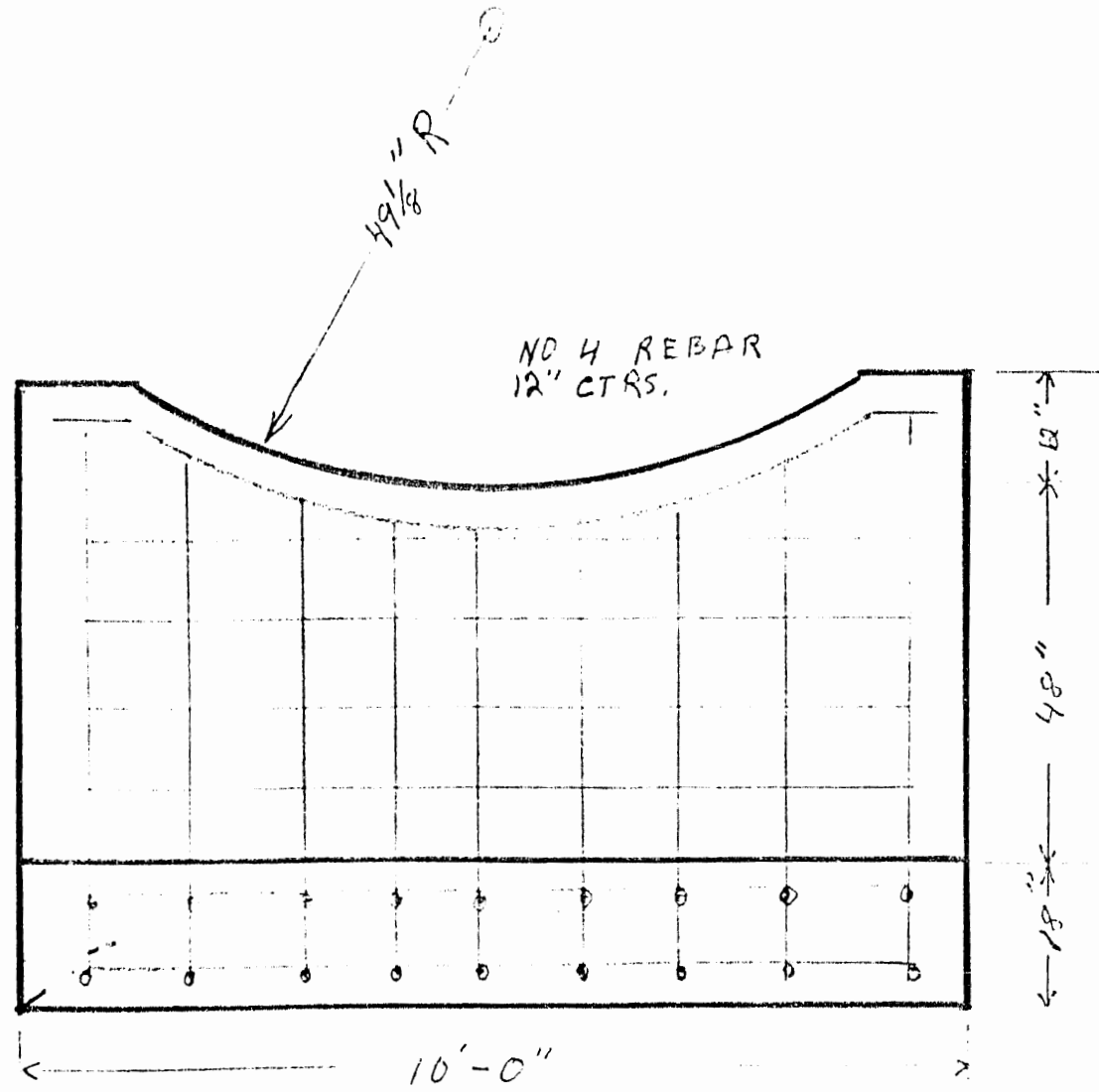

IF EXISTING TANK PIERS
CAN BE MOVED, THEY WILL
BE USED AT THE SITE

THE EXISTING PIERS ARE
CONSTRUCTED APPROXIMATELY
THE SAME HS PLANS
43 THICKS

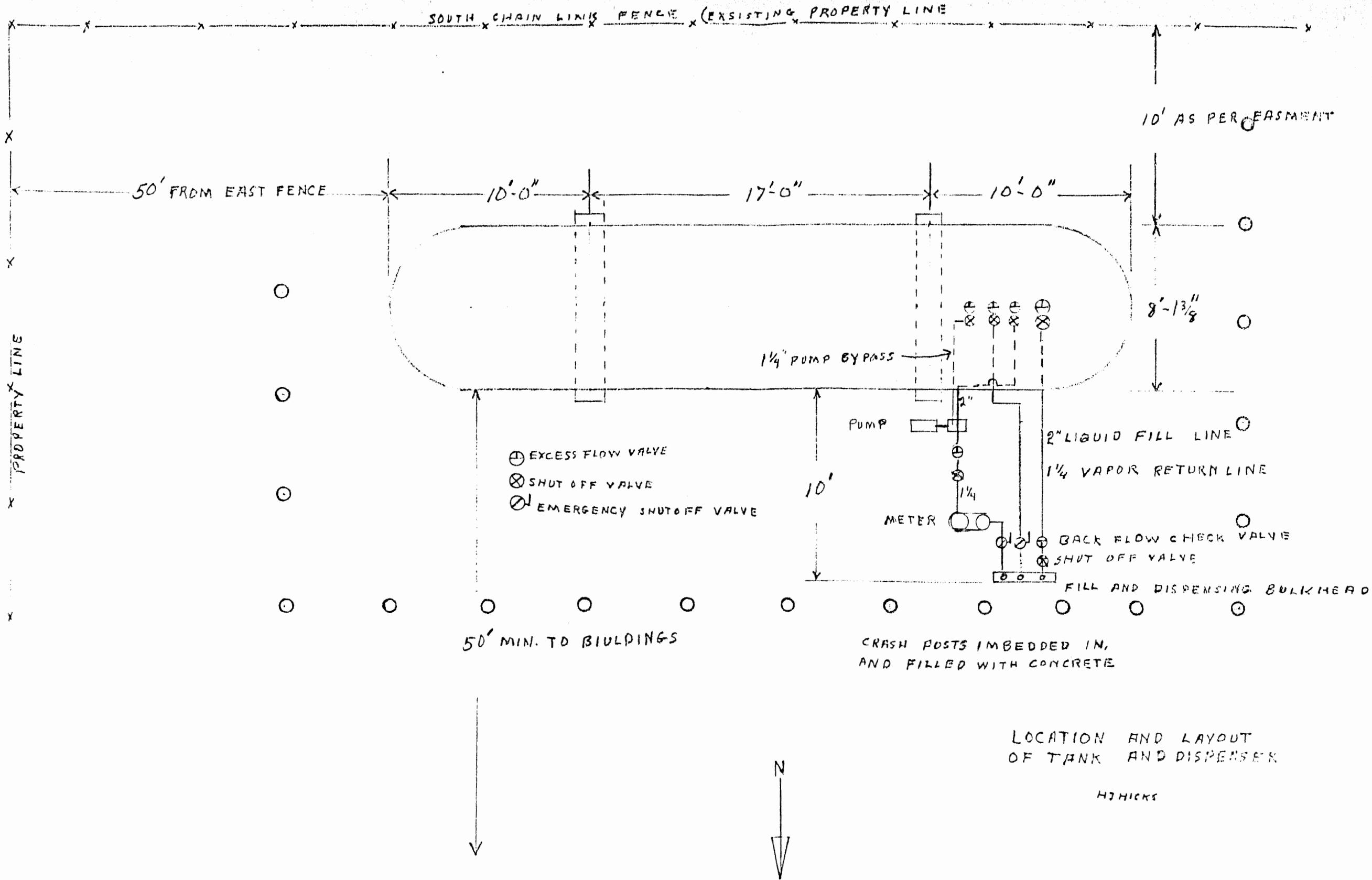

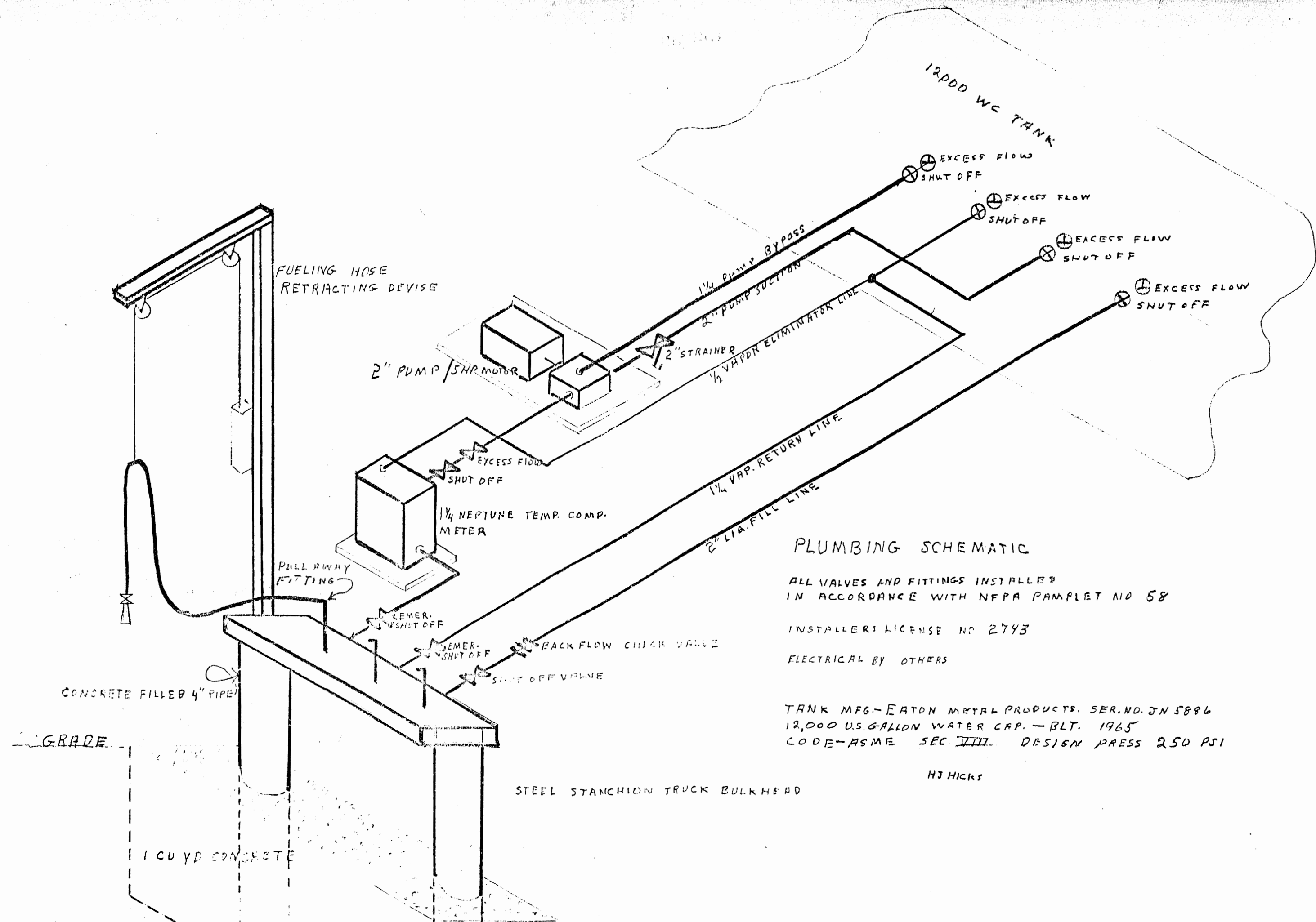

PLUMBING SCHEMATIC

ALL VALVES AND FITTINGS INSTALLED
IN ACCORDANCE WITH NFPA PAMPHLET NO 58

INSTALLER'S LICENSE NO 2743

ELECTRICAL BY OTHERS

TANK MFG.-EATON METAL PRODUCTS. SER. NO. JN 5886
12,000 U.S. GALLON WATER CAP. - BLT. 1965
CODE-ASME SEC. VIII. DESIGN PRESS 250 PSI

HJ HICKS

FUELING HOSE
RETRACTING DEVICE

2" PUMP / 5HP MOTOR

1/4 NEPTUNE TEMP. COMP.
METER

PULL AWAY
FITTING

CONCRETE FILLED 4" PIPE

GRADE

1 CU YD CONCRETE

STEEL STANCHION TRUCK BULKHEAD

12000 WC TANK

1/4 PUMP BYPASS
2" PUMP SUCTION

2" STRAINER

1/4 VAPOR ELIMINATOR LINE

1/4 VAP. RETURN LINE
2" 1/4" FILL LINE

EXCESS FLOW
SHUT OFF

EXCESS FLOW
SHUT OFF

EXCESS FLOW
SHUT OFF

EXCESS FLOW
SHUT OFF

EXCESS FLOW
SHUT OFF

EMER.
SHUT OFF

EMER.
SHUT OFF

BACK FLOW CHECK VALVE

SHUT OFF VALVE

37'-0" O.D.
29'-0" SHELL

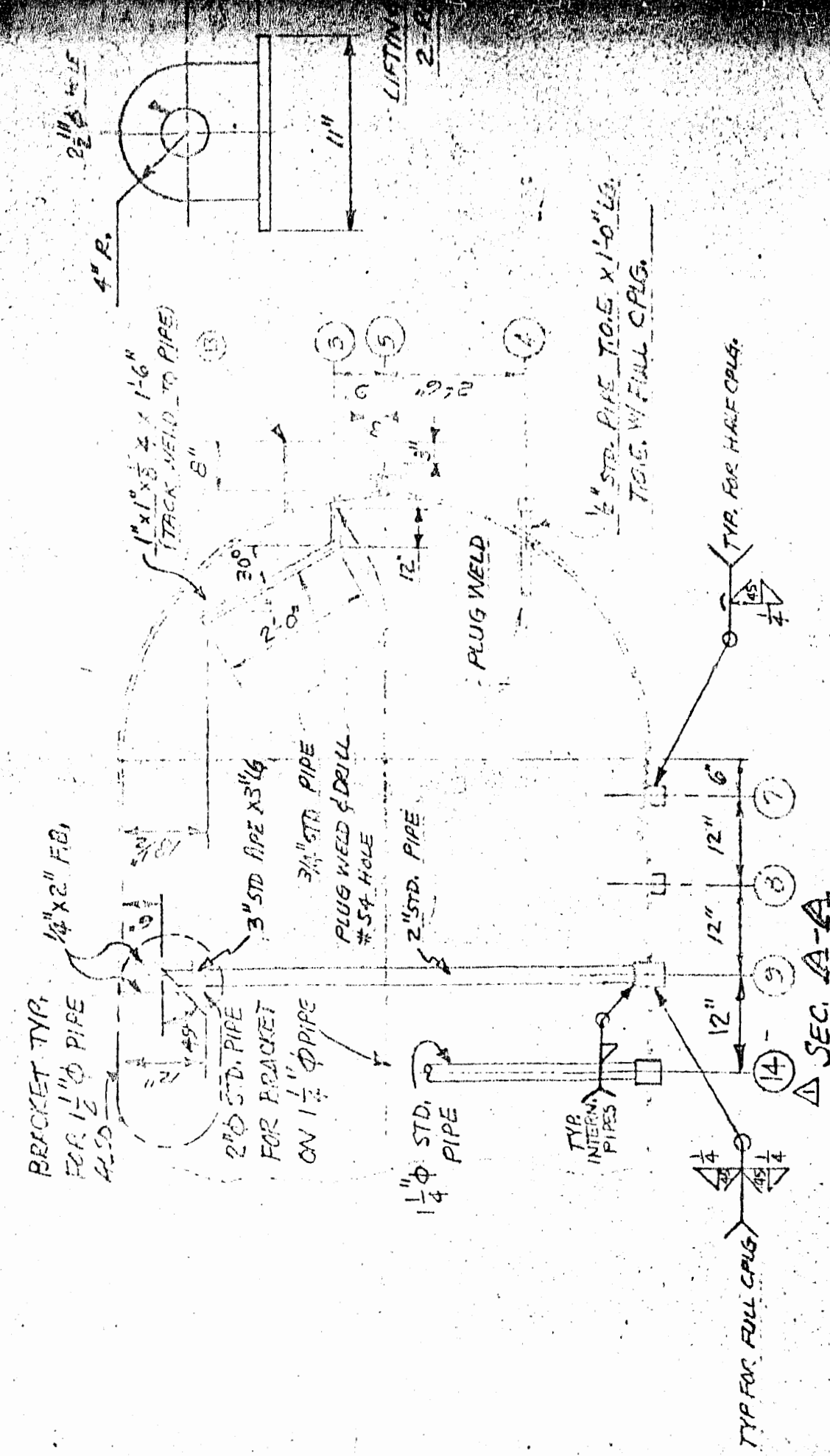
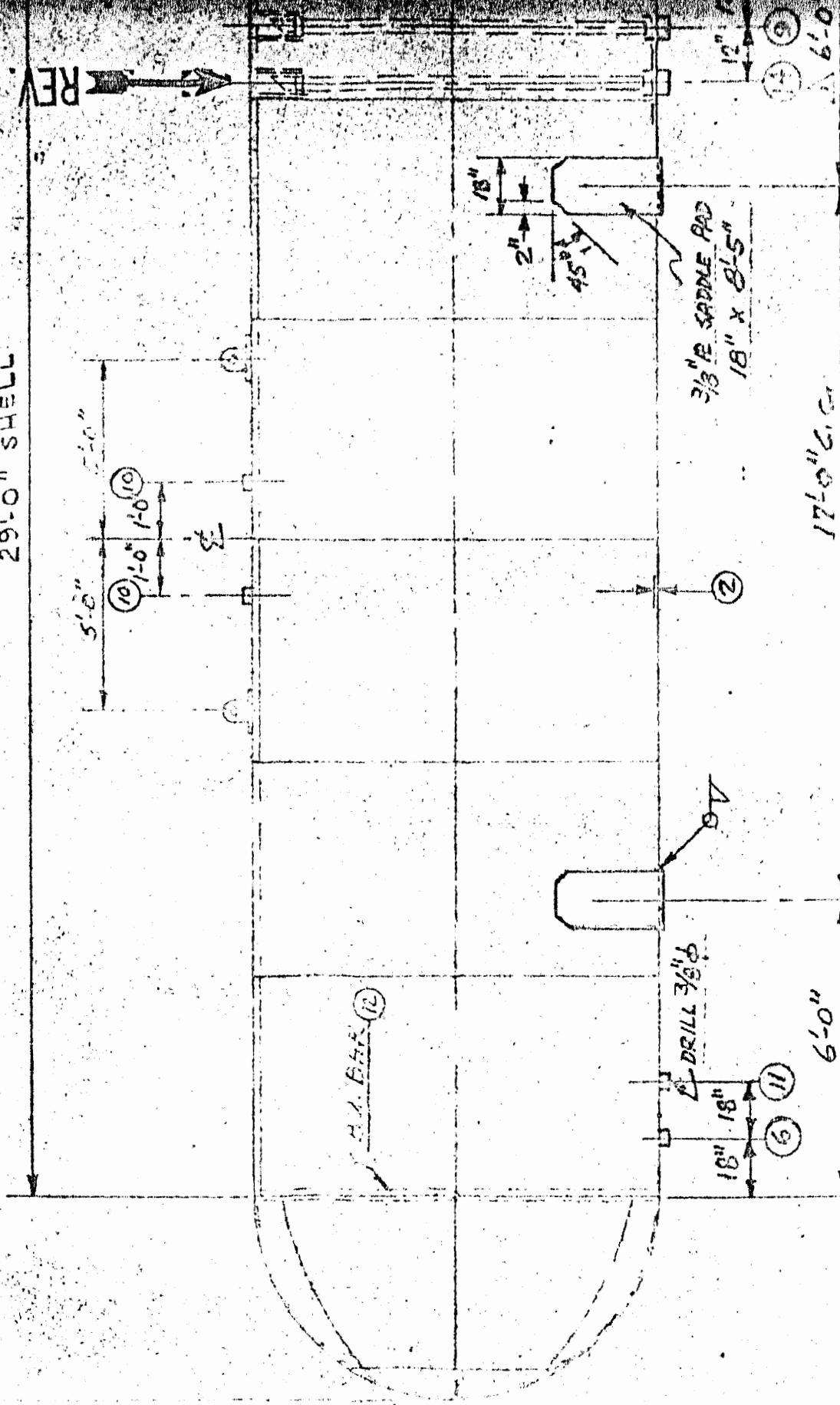

ORDINANCE NO. 152839

An Ordinance granting a revocable permit to Columbia Bus Service to install a 12,000 gallon liquid propane storage tank on the property at the Columbia Bus Service Storage and Maintenance lot at 10706 S. W. Capital Highway, under certain conditions, and declaring an emergency.

The City of Portland ordains:

Section 1. The Council finds:

1. That Columbia Bus Service, a school bus contractor, through Jim Rude, Terminal Manager, has requested a permit to install a 12,000 gallon propane storage tank on their property at 10706 S. W. Capital Highway.
2. That this facility is needed for the refueling of school buses.
3. That inspection of the plans and the site has been made by the Fire Marshal and Senior Building Inspector who recommend that the permit be granted under certain conditions.

NOW, THEREFORE, the Council directs:

- a. That the action of the Commissioner-in-charge of the issuing of the permit be ratified and that a revocable permit hereby be granted to Columbia Bus Service to install a 12,000 gallon propane storage tank at their bus storage and maintenance terminal at 10706 S. W. Capital Highway.
 1. That the four (4) drawings by Columbia Bus Service showing plot, piping, foundation and valves, drawing G-120-B, by Eaton Metal Products, the letter dated January 11, 1982, from Jan Fourier, property owner, the letter of January 25, 1982, from Jim Rude to Suzanne Vara, Bureau of Buildings, and the letter of application dated January 14, 1982, from Jim Rude, Columbia Bus Service, shall be made a part of this permit.
 2. That the tank, related appurtenances, and all piping and equipment shall be installed by a qualified, licensed Liquefied Petroleum Gas Fitter.
 3. That the installation shall be made in accordance with the basic rules and good practices established in National Fire Protection Association Standard #58, entitled "Liquefied Petroleum Gases, 1979."
 4. That all liquid discharge openings shall be fitted with a remotely controlled internal shut-off valve with thermal protection. The thermal control mechanism shall have a fusible element with a melting point not over 220° F. or less than 202°.

ORDINANCE No.

- 5. That the propane tank shall be located not less than 50 feet from any existing building, and that no other building shall be erected within 50 feet of the tank without express approval by the Fire Marshal.
 - 6. That the area immediately around the storage tank and related systems shall be secured by a minimum height 6-foot cyclone type fence, or if premises are fenced and secure, suitable barrier shall be installed to protect the propane tank and system from vehicular damage.
 - 7. That prior to the use of the tank for any propane storage or the system being put on the line, the system as a whole shall be inspected and approved by applicable bureaus of the City of Portland.
 - 8. That all electrical equipment shall be installed under permit from the Electrical Division, Bureau of Buildings, of the City of Portland.
- b. This permit shall not be in force and effect until and unless the permittee shall have first filed with the Auditor of the City of Portland, in form approved by the City Attorney, a document in writing accepting the terms and conditions of this ordinance. Upon the filing of the permittee, file a certified copy of this ordinance in the Deed Records of Multnomah County, Oregon.

Section 2. Inasmuch as this ordinance is necessary for the immediate preservation of the public health, peace and safety of the City of Portland in this: In order that ratification of the granting of the permit may be made and the required documents heretofore filed with the Auditor may be attached and recorded without delay; therefore, an emergency hereby is declared to exist and this ordinance shall be in force and effect from and after its passage by the Council.

Passed by the Council, FEB 11 1982

Commissioner Schwab
 January 28, 1982
 Matthew Greenslade/lh

Attest:

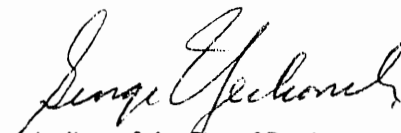
 Auditor of the City of Portland

ORDINANCE No.

5. That the propane tank shall be located not less than 50 feet from any existing building, and that no other building shall be erected within 50 feet of the tank without express approval by the Fire Marshal.
 6. That the area immediately around the storage tank and related systems shall be secured by a minimum height 6-foot cyclone type fence, or if premises are fenced and secure, suitable barrier shall be installed to protect the propane tank and system from vehicular damage.
 7. That prior to the use of the tank for any propane storage or the system being put on the line, the system as a whole shall be inspected and approved by applicable bureaus of the City of Portland.
 8. That all electrical equipment shall be installed under permit from the Electrical Division, Bureau of Buildings, of the City of Portland.
- b. This permit shall not be in force and effect until and unless the permittee shall have first filed with the Auditor of the City of Portland, in form approved by the City Attorney, a document in writing accepting the terms and conditions of this ordinance. Upon the filing of the permittee, file a certified copy of this ordinance in the Deed Records of Multnomah County, Oregon.

Section 2. Inasmuch as this ordinance is necessary for the immediate preservation of the public health, peace and safety of the City of Portland in this: In order that ratification of the granting of the permit may be made and the required documents heretofore filed with the Auditor may be attached and recorded without delay; therefore, an emergency hereby is declared to exist and this ordinance shall be in force and effect from and after its passage by the Council.

Passed by the Council, FEB 11 1982

Commissioner Schwab
January 28, 1982
Matthew Greenslade/lh

Attest:

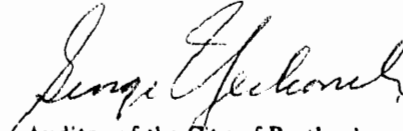
Auditor of the City of Portland

Calendar No. 358

ORDINANCE No. 152839

Title

An Ordinance granting a revocable permit to Columbia Bus Service to install a 12,000 gallon liquid propane storage tank on the property at the Columbia Bus Service Storage and Maintenance lot at 10706 S. W. Capital Highway, under certain conditions, and declaring an emergency.

THURSDAY

Filed FEB 4 1982

GEORGE YERKOVICH
Auditor of the CITY OF PORTLAND

By *Garbon*
Deputy

THE COMMISSIONERS VOTED AS FOLLOWS:		
	Yeas	Nays
JORDAN	/	
LINDBERG	/	
SCHWAB	/	
STRACHAN	/	
IVANCIE		

FOUR-FIFTHS CALENDAR	
JORDAN	
LINDBERG	
SCHWAB	
STRACHAN	
IVANCIE	

INTRODUCED BY
Commissioner Schwab

NOTED BY THE COMMISSIONER
Affairs <i>[Signature]</i>
Finance Administration
Safety
Utilities
Works

BUREAU APPROVAL	
Bureau: Fire Bureau	
Prepared By: M. Greenslade/lh	Date: 1/28/82
Budget Impact Review:	
<input type="checkbox"/> Completed <input checked="" type="checkbox"/> Not required	
Bureau Head: Francis J. Sargant	
<i>Francis J. Sargant</i>	

CALENDAR	
Consent <input checked="" type="checkbox"/>	Regular <input type="checkbox"/>

NOTED BY
City Attorney
City Auditor
City Engineer