

JUN 23 8 57 AM 1981

151630

GEORGE YERKOVICH, AUDITOR  
CITY OF PORTLAND, ORE.

ACCEPTANCE

BY \_\_\_\_\_

Portland, Oregon, May 28 1981

GEORGE YERKOVICH  
Auditor of the City of Portland,  
Room 202, City Hall  
Portland, Oregon 97204

Dear Sir:

This is to advise the City of Portland, Oregon, that I hereby accept the terms and provisions of Ordinance No. 151630, passed by the Council May 27, 1981, granting a revocable permit to Pacific Northwest Bell Telephone Company, a public utility, to install, occupy and maintain a precast underground utility vault in and under N.W. Glisan Street between N.W. 3rd Avenue and N.W. 4th Avenue, at a fee of \$37.75,

and in consideration of the benefits to be received thereunder by me I hereby agree to abide by and perform each and all of the terms and provisions thereof applicable to me.

Very truly yours,

PACIFIC NORTHWEST BELL TELEPHONE COMPANY

(CORPORATE SEAL)

*J. R. Deane R/W Mgr*

825 NE 20th Ave., Portland, OR 97232

Address

APPROVED AS TO FORM  
Approved as to form:

*Christopher P. Thomas*  
CITY ATTORNEY  
City Attorney

\*When an acceptance is required from a firm or corporation the Acceptance must be signed by an officer of the firm or corporation stating his or her official title, and corporations must affix the corporate seal.

## ORDINANCE NO. 151630

An Ordinance granting a revocable permit to Pacific Northwest Bell Telephone Company, a public utility, to install, occupy and maintain a precast underground utility vault in and under N.W. Glisan Street between N.W. 3rd Avenue and N.W. 4th Avenue, at a fee of \$37.75, and declaring an emergency.

The City of Portland ordains:

Section 1. The Council finds:

- i. Pacific Northwest Bell Telephone Company, through Michael R. Kincaid, Engineering Manager, 825 N.E. 20th Avenue, Room 204, Portland, Oregon, 97232, has requested permission under Section 17.56.040 of the City Code to install, occupy and maintain a precast underground utility vault in and under N.W. Glisan Street between N.W. 3rd Avenue and N.W. 4th Avenue.
2. The vault is needed to upgrade the existing system and provide additional service to the area.
3. The plan for the vault attached to this Ordinance as "Exhibit A" has been approved by the City Engineer.
4. The desired vault, under certain conditions, will not be detrimental to the public interest.

NOW, THEREFORE, the Council directs:

- a. A revocable permit is granted to Pacific Northwest Bell Telephone Company, permittee, to install, occupy and maintain a precast underground utility vault in and under N.W. Glisan Street between N.W. 3rd Avenue and N.W. 4th Avenue, and located as shown on the plan marked "Exhibit A" attached to and by this reference made a part of this Ordinance, subject to the following conditions:
  - (1) This permit is for the use of the street area only, and shall not exempt the permittee from obtaining any license or permit required by the City Code or ordinances for any act to be performed under this permit, nor shall this permit waive the provisions of any City Code, Ordinance, or the City Charter, except as herein stated.
  - (2) This permit is revocable at any time at the pleasure of the Council and no expenditure of money or lapse of time, or other act or thing, shall operate as an estoppel against the City of Portland, or be held to give the permittee any vested or other right. Upon revocation of this permit by the Council, the permittee shall within 30 days remove the vault and restore the street area as required by and to the satisfaction of the City Engineer.

# EXHIBIT - "A"

To construct and maintain a vault in and under the street area of N.W. Glisan Street between N.W. 3rd Avenue and N.W. 4th Avenue

For: Pacific Northwest Bell Telephone Co.  
825 N.E. 20th Avenue  
Portland, Oregon 97232

PRECAST CONCRETE VAULT  
TYPE 612-7TA DOUBLE ENTRY  
2-41" TYPE "B" COVERS

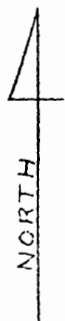
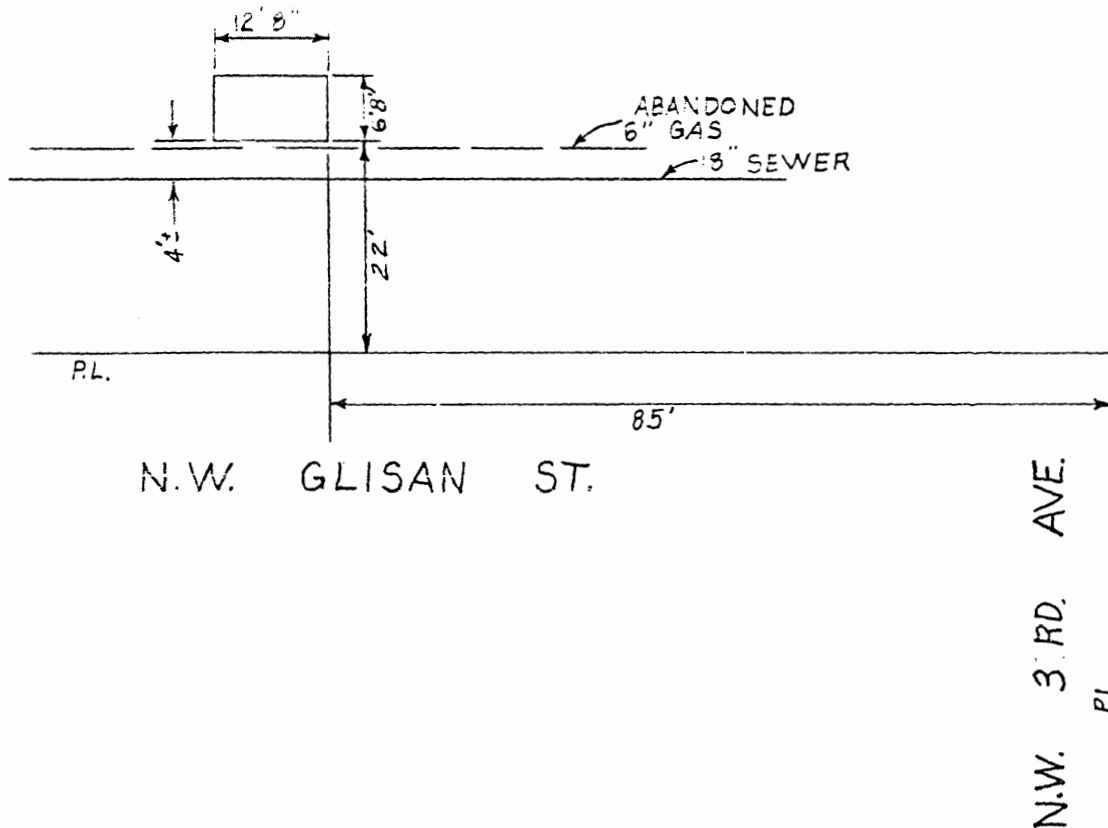

**APPROVED**

*Charles M. [Signature]*

By \_\_\_\_\_  
City Engineer  
Reg. Prof. Engr.

SCALE 1" = 20'  
DRAWN BY L.L.B.  
CHECKED BY HAH  
1/4 SEC. 3029 , DATE: 5-13-1981

## ORDINANCE No.

- (3) The permittee shall hold the City of Portland, its officers, agents, and employees free and harmless from any claims for damages to persons or property, including legal fees and costs of defending any actions or suits, including any appeals which may result from the use of the street area under this permit.
- (4) The permittee shall pay the permit fee of \$37.75 required by Section 17.24.020 of the City Code.
- (5) Before construction begins, the permittee shall obtain from the Traffic Engineer his requirements as to hours to work, traffic control, and the placing of necessary signs and barricades.
- (6) That no work to install this vault in the street area will be permitted during the Rose Festival ban from May 31, 1981 through June 15, 1981 unless otherwise permitted by the City Engineer.
- (7) If, during construction under this permit, it becomes necessary or expedient to modify the location or plan for the vault, the permittee shall first obtain the approval of the City Engineer on revised plans filed in duplicate with the City Engineer. One copy of the approved plan showing the change shall be filed by the City Engineer with the City Auditor to become a part of this Ordinance.

Section 2. This Ordinance will not become effective until the permittee has filed with the City Auditor a document, which has been approved by the City Attorney, accepting the terms and conditions hereof.

Section 3. The Council declares that an emergency exists because delay in the enactment of this Ordinance will result in an unnecessary hardship on the part of the applicant as to the status of the requested permit for construction of a structure in the street area of N.W. Glisan Street between N.W. 3rd Avenue and N.W. 4th Avenue; therefore, this Ordinance shall be in force and effect from and after its passage by the Council.

Passed by the Council, **MAY 27 1981**

Commissioner Mike Lindberg  
Harry A. Hendrickson:jmh  
May 13, 1981

Attest:

  
Auditor of the City of Portland

Calendar No. 1654

ORDINANCE No. 151630

Title

An Ordinance granting a revocable permit to Pacific Northwest Bell Telephone Company, a public utility, to install, occupy and maintain a precast underground utility vault in and under N.W. Glisan Street between N.W. 3rd Avenue and N.W. 4th Avenue, at a fee of \$37.75, and declaring an emergency.

THE COMMISSIONERS VOTED AS FOLLOWS:		
	Yeas	Nays
JORDAN		+
LINDBERG	/	
SCHWAB	/	
STRACHAN	/	
IVANCIE	/	

FOUR-FIFTHS CALENDAR	
JORDAN	
LINDBERG	
SCHWAB	
STRACHAN	
IVANCIE	

Filed MAY 20 1981

By George Yerkovich  
 Deputy Auditor of the CITY OF PORTLAND

INTRODUCED BY  
 COMMISSIONER MIKE LINDBERG

NOTED BY THE COMMISSIONER

Affairs: \_\_\_\_\_  
 Finance and Administration \_\_\_\_\_  
 Safety \_\_\_\_\_  
 Utilities \_\_\_\_\_  
 Works msl/ms

BUREAU APPROVAL

Bureau: Street & Structural Engineering  
 Prepared By: Harry A. Hendrickson:jmh Date: 5/13/81  
 Budget Impact Review:  
 Completed  Not required  
 Bureau Head: R. O. Schmidt  
 R. O. Schmidt, Chief

CALENDAR

Consent  Regular

NOTED BY

City Attorney \_\_\_\_\_  
 City Auditor \_\_\_\_\_  
 City Engineer Approved: John M. Lang, P.E.  
 By: R. O. Schmidt