

Residential Infill Project

AN UPDATE TO PORTLAND'S
SINGLE-DWELLING ZONING RULES

REVISED PROPOSED DRAFT
FEBRUARY 2019

VOLUME 1: STAFF REPORT AND MAP AMENDMENTS



Bureau of Planning and Sustainability
Innovation. Collaboration. Practical Solutions.
City of Portland, Oregon



Acknowledgements

City Council

Ted Wheeler, Mayor
Chloe Eudaly
Nick Fish
Amanda Fritz
Jo Ann Hardesty

Planning and Sustainability Commission

Katherine Schultz, Chair
Chris Smith, Vice Chair
Eli Spevak, Vice Chair
Jeff Bachrach
André Baugh
Ben Bortolazzo
Mike Houck
Katie Larsell
Daisy Quinonez
Teresa St Martin

Bureau of Planning and Sustainability

Ted Wheeler, Mayor, Commissioner-in-Charge
Joe Zehnder, Interim Director

Project Team

Sandra Wood, Principle Planner
Morgan Tracy, Project Manager
Shannon Buono, Senior Planner
Julia Gisler, City Planner
Love Jonson, Planning Assistant
Mark Raggett, Senior Urban Designer
Tyler Bump, Senior Economic Planner
Brandon Spencer-Hartle, Senior Planner

Additional Contributors

Marc Asnis, Modeling and Graphics
Eden Dabbs, Communications
Joan Frederiksen, West District Liaison
Julie Hernandez, Map App Designer
Krista Gust, Graphic Designer
Jena Hughes, Planning Assistant
Nick Kobel, Associate Planner
Neil Loehlein, GIS Mapping
Leslie Lum, East District Liaison
Kevin Martin, Tech Program Manager

Derek Miller, GIS Mapping/Map App
Phil Nameny, City Planner
Nan Stark, North/Northeast District Liaison
Marty Stockton, Southeast District Liaison

Partner Bureaus/Agencies

Bureau of Development Services

Stephanie Beckman, Supervising Planner
Kristin Cooper, Senior Planner
Leah Dawkins, City Planner
Matt Wickstrom, Senior Planner
Sean Williams, City Planner

Bureau of Transportation

Courtney Duke, Senior Planner
Bob Haley, Senior Planner
Bob Kellet, Transportation Planner
Kurt Kruger, Development Review Manager
Teresa Montalvo, Land Use Review Supervisor

Bureau of Environmental Services

Stephen Himes, Development Supervisor
Elisabeth Reese Cadigan, Dev. Services Mgr.

Bureau of Housing

Jessica Conner, Housing Policy Planner
Kim McCarty, Housing Program Coordinator
Mathew Tschabold, Management Analyst

Portland Parks and Recreation

Katie Dunham, Senior Planner

Fire Bureau

Dawn Krantz, Land Use Review Technician

Police Bureau

Richard Kepler, Crime Prevention Specialist

Water Bureau

Mike Saling, Supervising Engineer
Erin Mick, Senior Program Manager

TriMet

Eve Nilenders, Planner

Metro

Jonathan Williams, Senior Dev. Project Mgr.

Consultants

EnviroIssues – Facilitation/Public Engagement
DECA Architecture, Inc. – Architectural models
Dyett and Bhatia – Urban and Regional Planners
Johnson Economics, Inc. – Economic Analysis

Executive Summary

Portland's success is tied to the vibrancy and diversity of our neighborhoods.

The Residential Infill Project is just one tool of many needed to address the housing issues in our city. Affordable housing mandates, rent stabilization and community housing partnerships are also important to address the needs of our most vulnerable community members.

A house is made of brick and mortar, but home is made by the people who live there.

—M. K. Soni

Any plan that ignores the exclusionary pattern of single-dwelling zones will further separate our community between those that “have” and those that “need,” making these areas even more exclusive enclaves for only the wealthiest residents. The Residential Infill Project seeks to remove regulatory barriers that exclude people with fewer means from our neighborhoods to ensure Portland is resilient, prosperous and equitable in the face of our challenging future.

Zoning Code Changes

The Residential Infill Project includes 12 key proposals to increase housing choice in single-dwelling zones, while limiting their overall size to reduce housing costs, retain a compatible scale and improve building form. This is achieved through innovative changes to development rules in the base zones.

Proposals relating to **housing options and scale** are described beginning on **page 12**. These include allowances for duplexes, triplexes, fourplexes and additional accessory dwelling units (ADUs), along with limits on building size using a new floor area ratio (FAR) tool.

Building design proposals begin on **page 30**. These new rules include changes to address building height, limit tall flights of stairs to the front door, remove minimum parking requirements and limit front garages and paving, as well as improve the look of houses built on narrow lots.

Map Changes

The Zoning and Comprehensive Plan Map changes fall into the following categories:

Apply a new ‘z’ overlay zone: Describes areas where additional housing types should *not* be allowed based on natural resources or hazards. The new ‘z’ overlay in those areas will maintain current allowances for duplexes on corner lots or a single ADU with a house. See **page 40**.

Rezone historically narrow lots: Some areas with historically narrow lots are proposed to be changed from R5 to R2.5. See **page 46**.

Remove the current ‘a’ overlay zone: The Alternative Design Density (‘a’) overlay zone in single-dwelling zones is being deleted, with increased housing allowances incorporated into the base zones. See **page 50**.

The Revised Proposed Draft adds increased housing options to the base zone and proposes a new Constrained Sites (‘z’) overlay zone for properties that are *not* eligible for these housing options. Consequently, over 90 percent of lots in the R7, R5 and R2.5 zones will be eligible to use these additional housing options.

In addition, approximately 7,000 parcels are proposed to be rezoned from R5 to R2.5 (higher density) to reflect the existing platted lot size pattern and increased FAR allowance based on their proximity to transit, shops and other amenities.

Outcomes

The construction of additional housing types is expected to occur incrementally. As our housing stock ages, rehabilitation and remodeling will help prolong the useful life of many of these structures, but some houses will ultimately need to be replaced. As land costs continue to climb and fewer buyers are able to afford expensive single detached houses, more middle housing types (duplexes, triplexes and fourplexes) will begin to emerge to respond to that need. When that occurs, new development will be more seismically sound, free of lead and asbestos, and more energy-efficient.

This middle housing will be distributed in neighborhoods across the city. Single-dwelling neighborhoods will continue to be mostly traditional detached houses, infused with other types of units over time. The addition of 24,000 units in triplexes or fourplexes over the next 20 years means roughly 300 to 400 new buildings per year. With nearly 150,000 existing houses, single houses will still account for *more than 95 percent* of the total housing stock in these neighborhoods.

Note that ADUs were once opposed by neighborhoods as a one-size-fits-all approach and a detriment to single-dwelling neighborhoods. Today, they are commonplace and have gained far greater acceptance in many neighborhoods for their benefits and flexibility. Increasing allowances for two ADUs or internal conversions to add units will offer homeowners even greater potential to gently increase the housing capacity within their neighborhoods—without the disruption of redevelopment.

Impacts

These new housing types will complement existing neighborhoods. Smaller in size, they provide more choices for first-time homebuyers, downsizing empty-nesters and middle-wage earners. Also, current homeowners that already have an ADU will be able to add another ADU. These smaller units can house young couples, students, grandparents or caregivers, offering an alternative to larger apartment buildings.

Still others will continue to be burdened by higher prices in the housing market. Vulnerable populations of low-income renters, people of color and seniors on fixed incomes will continue to feel the pressures of rent increases and could be displaced through redevelopment. Homeowners are not immune, though they have more control over deciding whether to sell. Strategies to decrease the risk of displacement are needed regardless of the proposals in the Residential Infill Project.

Conversely, without allowing additional housing types to occur in single-dwelling neighborhoods, one conclusion is certain: When homes are demolished or when vacant sites are developed, the resulting redevelopment will result in only *one* house (likely large and expensive), when options for two, three or four households could have been built in its stead. This will continue to increase pressure and demand on the fixed number of homes allowed in these neighborhoods, putting homeownership further out of reach for many.

Together, these revised proposals reduce the cost of housing, limit the size of new houses, mitigate and lessen displacement citywide, and prioritize a wide range of housing types for people of all ages, abilities and incomes.

Table of Contents

Volume 1

Section 1: Introduction	1
Section 2: Public Involvement	6
Section 3: Summary of Amendments	11
Section 4: Analysis of Amendments	12
Section 5: Map Amendments	40

Volume 2 (under separate cover)

Section 6: Zoning Code Amendments

Section 7: Comprehensive Plan Amendments

Volume 3 – Appendices (under separate cover)

Appendix A: Guidance from the Comprehensive Plan, BPS Staff, September 2017

Appendix B: *Economic Analysis of Proposed Changes to the Single-Dwelling Zone Development Standards*, Memorandum from Johnson Economics, November 2018

Appendix C: *Use of Floor Area Ratios (FARs) in Single Family Zoning*, Dyett & Bhatia Urban and Regional Planners, June 2016

Appendix D: Catalogue of 2015 New Single-Family House Permits in the R2.5 zone, BPS Staff, 2017

Appendix E: *Visitability Best Practices*, Alan DeLaTorre. Ph.D., Alex Freeman, and Matthew Wadleigh (Portland State University), June 27, 2017

Appendix F: R2.5 Zone Changes by District, BPS Staff, 2018

Appendix G: Portland’s Historically Narrow Lots, BPS Staff, 2017

Appendix H: Displacement Risk Analysis, BPS Staff, February 2019

Section 1: Introduction

As Portlanders, we have an opportunity to update the rules that shape our residential neighborhoods so that more people can live in them, while limiting the construction of very large new houses.

Portland's residential neighborhoods are the places where we spend time with friends and family. Where we join our neighbors for block parties, host barbeques in the backyard and chat with the mail carrier. Where we walk our dogs, take our kids to school and grab a coffee. These interactions make our communities stronger and safer.

As a city and community, we're committed to increasing access to these great neighborhoods, while expanding economic opportunities for households and reducing our impact on the environment.

These decisions are particularly important because **Portland's population continues to grow**. By 2035, the number of households in the city will increase by more than 100,000. That's roughly 200,000 new residents—or 30 percent more people than live here today.

The **composition of our neighborhoods** is also changing. The city is becoming more diverse, the overall population is aging and the number of people per household is getting smaller (from 2.3 persons today to 2.1 in 2035, which is less than half the average size of households just a century before). But despite shrinking households, there are few options for smaller households to live in residential neighborhoods, where increasing land costs and market trends have produced mostly larger houses.

The **rising cost of housing** is a top concern across the city, as more people are finding it difficult to afford housing—whether they are buying or renting. Between 2011 and 2015, the median home sale price citywide rose 44 percent—or more than \$100,000. And as of 2015, the median home sale price exceeded \$400,000 in more than half the neighborhoods in the city.

Portlanders are also worried about **the construction of very large homes** that are more expensive and can overwhelm surrounding older homes.

To address these issues around growth and change, the City of Portland is taking a fresh look at the rules affecting development in residential neighborhoods to ensure that housing is available in a variety of sizes and prices for all Portlanders, regardless of age, income, ability, race or origin.

Over the past three years, the Bureau of Planning and Sustainability has engaged Portlanders in the development of proposed changes to our residential zoning rules through online surveys, open houses, public hearings and e-mail updates, resulting in more than 15,000 comments and responses. Portlanders will also have opportunities to share their feedback through public testimony to the City Council.

Why is it important to revisit the zoning code for residential neighborhoods?

By updating the rules that govern the types of housing allowed in our neighborhoods, we have an opportunity to accomplish two main goals:

- 1) Expand housing choices in residential neighborhoods to help ensure a more inclusive and diverse community.
- 2) Limit the size of new buildings to bring them more in line with existing homes.

Just as important as the *amount* of housing in the city are the *types* of housing that are available and *where* that housing is located. If adopted by City Council, the proposed rule changes would expand the range of available housing choices across more neighborhoods. The proposal allows more housing units, *but only if they follow the new limits on the size of new buildings.*

Currently, on many lots, builders can build houses up to 6,750 square feet for just a single household. This proposal would allow for more types of housing, including duplexes, triplexes and even fourplexes when lots meet certain minimum size requirements. Additionally, more opportunities are afforded to create accessory dwelling units (ADUs) with houses and duplexes. In all these cases, new limits would cap the structure size to less than what can be built on a lot today. The proposal also includes flexibility and incentives to retain existing houses or encourage building affordable housing units. Finally, the zoning on narrow lots is updated to allow for increased homeownership options in high-amenity neighborhoods.

Why this is important

The rules that govern the types of housing allowed in our neighborhoods also affect who can live there. These rules are meant to be adapted to suit the evolving needs and values of our communities.

Together, these new rules help increase housing options in the form of ADUs, duplexes, triplexes and fourplexes—smaller and less expensive options that allow for more people to live in our residential neighborhoods while also limiting the construction of very large houses.

Addressing inequity in our community

A history of racially discriminatory decision-making and public policies have contributed to many of today's inequitable outcomes for communities of color. While some groups and neighborhoods prospered, Black, Latino, Native American and immigrant households have faced structural barriers to housing stability and economic mobility. The historic use of racially restrictive covenants and redlining by both public and private entities directly contributed to today's racial disparities in homeownership rates and wealth attainment. It also contributed greatly to the geographic racial segregation that still exists.

Portland's new Comprehensive Plan includes policies to address equity, prevent displacement and provide for ongoing affordability. The proposal to update zoning rules in residential neighborhoods is consistent with these policies. It is intended to create opportunities for more types of housing development. The proposals were evaluated in terms of whether, how and where land use changes could cause further harm to historically under-served and under-represented communities.

Appendix H: Displacement Risk and Mitigation provides a detailed account of the methodology used to identify vulnerable households and determine relative risk. The analysis shows a significant reduction in potential displacement as a result of the project proposals over the baseline scenario. While this reduced risk is encouraging, these zoning changes do not eliminate displacement risk and much greater effort and resources will still be required to right previous systemic wrongs and ensure community stability and future prosperity. The appendix also includes strategies specifically tailored to vulnerable renters and vulnerable homeowners. These strategies could be employed or further bolstered to address and prevent further harms to under-represented communities.

Direction from the 2035 Comprehensive Plan

Portland's 2035 Comprehensive Plan guides how and where land is developed to prepare for and respond to population and job growth. This proposal offers amendments to some of the Comprehensive Plan's most important implementation tools—the Zoning Code and Zoning Map. In addition, the proposal would amend the Comprehensive Plan map itself.

The amendments proposed are consistent with the Guiding Principles, goals and policies of the Plan. The following describes how the Plan shaped the proposals. Additional policy direction is provided in *Appendix A: Guidance from the Comprehensive Plan*.

The 2035 Comprehensive Plan gives direction to use equity as a lens when creating and assessing plans and programs. This is articulated in a Guiding Principle focused on equity and a suite of policies around displacement risk and mitigation. This approach is the result of the Equity Framework and Healthy Connected City Strategy in the Portland Plan. These have been incorporated into several policies in the 2035 Comprehensive Plan that direct the City to evaluate plans and investments for the potential to increase displacement and to mitigate for anticipated impacts.

Guiding Principles

The 2035 Comprehensive Plan includes five guiding principles, recognizing that implementation of the Plan must be balanced, integrated and multi-disciplinary. The proposed residential zoning changes help advance these guiding principles in the following ways:

1. Equity. *Promote equity and environmental justice by reducing disparities, minimizing burdens, extending community benefits, increasing the amount of affordable housing, affirmatively furthering fair housing, proactively fighting displacement, and improving socio-economic opportunities for under-served and under-represented populations. Intentionally engage under-served and under-represented populations in decisions that affect them. Specifically recognize, address, and prevent repetition of the injustices suffered by communities of color throughout Portland's history.*

The proposal furthers this principle by increasing the range of housing types and choices available across the city. Increased opportunity for additional housing options, incentives for affordable housing and reductions in the allowed size of new houses help stabilize and impede rising housing costs. Intentional outreach was conducted to engage with historically under-represented populations and continued in the *Discussion Draft* phase. A Displacement Risk Analysis was also conducted to determine the extent of potential impacts on affected communities. The analysis found that with the increase in allowable units, the net number of impacted vulnerable households

was reduced by about one-third compared to the default Comprehensive Plan scenario, although some areas may experience higher rates of displacement (see *Appendix H*).

2. Economic Prosperity. *Support a low-carbon economy and foster employment growth, competitiveness, and equitably-distributed household prosperity.*

This principle is furthered by providing for smaller, less energy-intensive, less expensive housing options in more areas throughout the city. This offers more opportunities for people across a wider range of the income spectrum to find housing in and around areas of retail and service-sector job growth. More people in and near these areas help to encourage and sustain neighborhood businesses. Allowing increased and well-located housing options affordable to more families supports household prosperity. This helps people spend less of their income on combined housing, utilities and transportation costs and invest a greater percentage of their income in the local economy.

3. Human Health. *Avoid or minimize negative health impacts and improve opportunities for Portlanders to lead healthy, active lives.*

The proposal furthers this principle in several ways. It minimizes personal stress caused by housing instability by allowing for diverse housing types that can better meet changing household preferences, needs, abilities and economic conditions; promotes social interaction through requirements that allow people of all abilities to visit others; and reduces financial stress and increases potential for active living through reduced automobile use by placing housing in areas with greater active transportation and transit options.

4. Environmental Health. *Weave nature into the city and foster a healthy environment that sustains people, neighborhoods, and fish and wildlife. Recognize the intrinsic value of nature and sustain the ecosystem services of Portland's air, water, and land.*

The proposal furthers this principle by increasing open space and natural features while promoting development that responds to positive qualities of the natural setting and site conditions. By implementing a new floor area ratio (FAR) tool, the proposal reduces the allowable amount of development, which reduces material use and waste, better accommodates sustainable stormwater solutions and provides options for additional space to grow and preserve trees. The proposal avoids impacts to areas with significant habitat resource value through the application of a new constraint overlay zone. Also, more compact housing is the single most effective way of reducing heating and cooling demands, lowering energy use and carbon emissions, thereby improving air and water quality.

5. Resilience. *Reduce risk and improve the ability of individuals, communities, economic systems, and the natural and built environments to withstand, recover from, and adapt to changes from natural hazards, human-made disasters, climate change, and economic shifts.*

This principle is furthered by providing additional opportunities for compact housing development. These smaller units are more energy-efficient than most older homes and comparable larger new homes. New housing and houses that are retrofitted for additional units will be built to modern

seismic and fire safety codes, thereby providing additional resiliency. Areas prone to flooding or landslides or with inadequate utility infrastructure were carefully evaluated when determining where additional housing units should be allowed. Moreover, by providing for a broader range of housing types and sizes, people are better able to find a dwelling suited to their needs and circumstances in changing economic climates.

A paradigm shift toward more “middle” housing

Middle housing is a term used to describe housing forms that are compatible in scale with single-dwelling areas but accommodate more units. These housing types range from duplexes, triplexes, and fourplexes on the low-intensity end to bungalow courts in the middle of the spectrum and live-work units and courtyard apartments on the higher-intensity end. This project focuses on the lower-intensity end of the “middle” housing spectrum in single-dwelling zones, while the Better Housing by Design project is exploring the complete range of middle housing in multi-dwelling zones.

Consider a young Portland couple, renting a one-bedroom apartment, that may not be able to afford the significant investment needed to buy a house. As their family grows, they may seek additional indoor and outdoor living space in a walkable neighborhood with good access to amenities. A unit in a duplex or triplex could provide this opportunity at a price that is more affordable than that of a single-family home. In addition, if this young couple moves out of a lower-rent apartment, that unit is then freed up for someone else who is entering the housing market.

Or consider an older adult who no longer wants or is able to take care of a large house and yard but wants to remain near long-time neighbors and businesses in a familiar setting. Community-oriented cohousing and accessory dwelling units (ADUs) could provide viable alternatives for meeting these needs in a desired location.

In both scenarios, greater housing choice typically means more variety in unit prices and living arrangements, and therefore a better chance to find a house in a location and at a price that meets a wider range of needs. Additional housing options, when built at a scale and form compatible with single-dwelling neighborhoods, are considered the “middle” housing spectrum. Duplexes, triplexes and fourplexes along with additional ADUs comprise the part of the spectrum that the Residential Infill Project aims to expand. These new units will be built at a size that complements older, existing homes that have defined Portland’s neighborhoods for decades.

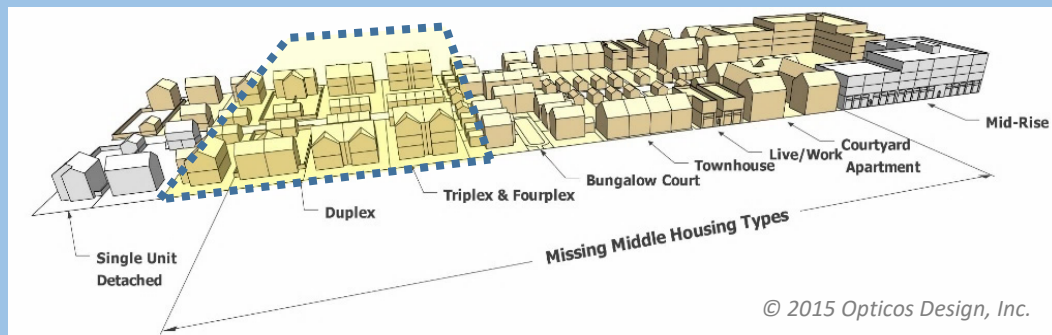

This proposal recommends allowances for a small segment of the range of middle housing types (shown in the dashed box) that can be achieved at a scale and within a form that is compatible with the character of many of the city’s single-dwelling residential neighborhoods.

Section 2: Public Involvement

This project is being completed in two phases. The concepts for the proposals were developed in Phase I, which took place in 2015 and 2016. The proposals in this report are part of the legislative phase (Phase II) and include the Zoning Code and Zoning Map amendments needed to implement the concepts from Phase I. Input from the public in Phase I was invaluable in developing the proposals in Phase II.

We are currently in Phase II. In Fall of 2017 the public reviewed and provided comment on the staff's proposed zoning code and map amendments (the *Discussion Draft*). The proposals in this draft—the *Revised Proposed Draft*—reflect testimony received and deliberation by the Planning and Sustainability Commission (PSC) between May and September 2018.

Phase I: Concept Development

Public involvement from July 2015 to December 2016

Stakeholder Advisory Committee

In September 2015, former Mayor Charlie Hales appointed an advisory committee to assist the Bureau of Planning and Sustainability with the Residential Infill Project. The Stakeholder Advisory Committee (SAC) was composed of nominees from each of the District Coalition Offices, the Planning and Sustainability Commission, East Portland Action Plan, Home Builders Association of Metropolitan Portland, United Neighborhoods for Reform and the Immigrant and Refugee Community Organization. In addition, 13 members-at-large were chosen to ensure the committee was well-balanced among individuals representing neighborhood interests, the development community and those who bring a different perspective related to single-dwelling housing issues, such as anti-displacement, aging and disability, and historic preservation advocates. A balance in terms of gender composition, geographic distribution and community networks was also considered while forming the SAC. (*See Stakeholder Advisory Committee Member Biographies.*¹)

The SAC met 14 times between September 2015 and October 2016. In addition to regular meetings, SAC members attended neighborhood walks and a full-day design workshop to develop a range of concepts and options for the Residential Infill Project concept proposal. A Facebook group was created to provide a forum for SAC members to share and discuss issues and articles related to their work on the project. Members of the public could view all postings, links and uploads to this group page.

The SAC was an advisory group and was not expected to come to a consensus. (*See the SAC Charter and the June 2016 SAC Summary Report.*^{2,3})

¹ "Member Biographies," Bureau of Planning and Sustainability, <https://www.portlandoregon.gov/bps/article/544829>.

² *Stakeholder Advisory Committee Charter*, Bureau of Planning and Sustainability (November 2015), <https://www.portlandoregon.gov/bps/article/564206>.

³ *Stakeholder Advisory Committee Summary Report*, Bureau of Planning and Sustainability (June 17, 2016), <https://www.portlandoregon.gov/bps/article/581153>.

Public Outreach and Feedback

The SAC was just one element of an inclusive public engagement effort. Other efforts included regular project updates, an online open house and questionnaires, public events and City Council hearings. Public input helped formulate the recommendations in the Residential Infill Project Concept Report.

Project Updates

Updates on the project were shared in several ways: e-updates sent to the project mailing list, blog posts for news and updates, BPS E-newsletters and BPS social media accounts (Facebook, NextDoor and Twitter).

Transparency in SAC Meetings

All SAC meetings were open to the public with time for public comments (oral and written) during the meetings. In addition to regular meetings, the public was invited to an open house after the SAC design workshop in January 2016. Announcements of upcoming meetings and summary notes of each meeting were included in e-updates and blog posts. In addition, all SAC meeting agendas, summaries and meeting materials were posted on the project website.

Online Questionnaire

Over 7,000 online questionnaire responses were received between December 9, 2015 and January 12, 2016. The questionnaire asked participants to prioritize the residential infill issues most important to them. The majority of respondents throughout the city said housing affordability and neighborhood compatibility were their top concerns. Other top concerns included demolition of viable homes, preservation of farm and forestland outside the city, and loss of green spaces and tree canopy. Staff used the results to help identify key community values for regulating development in single-dwelling zones. Concepts were developed for community review in the spring. In addition to the many voices and opinions that were shared, the demographic results also helped pinpoint where additional targeted outreach was needed to gain additional input from those not well-represented in this survey. Results, including key findings, methodology, demographic information, responses by geographic areas and demographic groups, and open-ended comments summarized by topic areas were posted on the project website and shared with the SAC.

Public Review of Concept Report

The public review period for the Residential Infill Project Concept Report and Draft Proposals occurred from June 15, 2016 through August 15, 2016. Opportunities for the public to learn more about the project and give staff feedback included:

- An online open house and second questionnaire that offered the public a chance to learn about the project and provide comments on the proposals;
- A series of open houses around the city to learn about the project, review the proposals, ask questions and share feedback;
- Meetings in collaboration with community members including Oregon Opportunity Network's public forum on the Residential Infill Concept Report and Draft Proposals and a special meeting for older adults and people with disabilities; and

- Meetings with organizations to gather feedback and help distribute information about the draft proposal to their members, such as Anti-Displacement PDX, REACH CDC and the Portland Housing Center, among others.

During the eight-week public review period, **over 700** people attended an open house or meeting where the proposals of the project were presented, **8,604** people visited the online open house and staff collected more than **1,500** public comments from the online questionnaire, comment forms, chart pack notes at open houses, emails and letters.

The *Summary Report of Public Comments on the Draft Proposal* includes six appendices that provide the entire text of the comments received, the notes from the open house question and answer sessions and demographic cross-tab tables for the questionnaire responses.^{4,5}

Staff used the feedback to refine the concepts in the Recommended Concept Report to City Council published on October 17, 2016.

Media Coverage

The project received much attention by several news outlets. Stories appeared in several neighborhood newspapers, in addition to *The Oregonian*, *Portland Tribune*, *Willamette Week* and *Portland Mercury*. Staff appearances on OPB, KBOO, KGW, FOX12 and KATU helped to disseminate information and publicize upcoming City Council hearings.

City Council Public Hearing

At the request of former Mayor Charlie Hales, staff brought the concepts directly to City Council so that he would be able to provide input prior to the end of his term. City Council held public hearings on November 9 and November 16, 2016. Nearly 120 people testified in person; Council also received approximately 550 letters and emails during their review. In December 2016 Council passed several amendments to the concepts and passed a resolution directing staff to develop Zoning Code and mapping amendments to implement the concepts. Staff began the code development and map amendment process in early 2017.

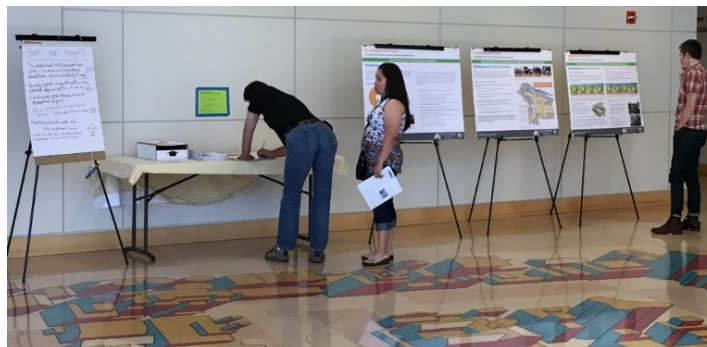

⁴ *Public Comments on the Draft Proposal: Summary Report*, EnviroIssues (September 2016), <https://www.portlandoregon.gov/bps/article/590169>.

⁵ "Appendices: Public comments received on the Draft Concept Proposals," Bureau of Planning and Sustainability (September 2016), <https://www.portlandoregon.gov/bps/71629>.

Phase II: Code and Map Amendments

Public involvement from October 2017 through project completion

As the code and map amendments are developed, the public will have had a chance to review and provide comments on the proposals in the *Discussion Draft*, the *Proposed Draft* to the Planning and Sustainability Commission (PSC), and PSC's *Recommended Draft* to City Council.

Discussion Draft

The public review period for the Residential Infill Project *Discussion Draft* was from October 3 to November 30, 2017. During this time the public had opportunities to learn about the proposals at a kick-off meeting and six drop-in events throughout the city. Staff also presented the proposals at various community meetings and had numerous conversations with groups and individuals through email and phone inquiries. In addition, an interactive online Map App was available that showed parcel-specific information about how the proposals would affect individual properties.

Comments were submitted via mail, email or online using a comment form on the project website. A [What We Heard Summary Report](#) is included on the project website which describes the range of feedback that staff received, along with an [appendix](#) that includes all comments received.^{6,7}

By the numbers

- **433** people submitted **3,425** comments through the online and paper comment forms
- **249** emails were sent to project staff
- Staff received **46** letters from organizations or groups which included nonprofits and advocacy groups, public-sector agencies and commissions, coalitions of for-profit housing developers, business interests, and neighborhood associations and district coalitions
- **36** comments were written on a lobby exhibit in the 1900 Development Services Building

How we got the word out

- News blogs featured on the Residential Infill Project website
- Monthly email updates were sent to the project mailing list (over 1,000 email addresses as of January 2018) to provide project updates and public input opportunities.
- BPS and Bureau of Development Services e-newsletters
- Posts by BPS on NextDoor, Twitter and Facebook (many of which were shared by others)
- Articles in local newspapers (including *The Oregonian*, *Daily Journal of Commerce* and *Portland Tribune*)
- Media coverage on local TV news stations and local radio programs
- BPS project staff provided updates to neighborhood associations and other community groups

⁶ *What We Heard Summary Report*, Bureau of Planning and Sustainability (January 2018), <https://www.portlandoregon.gov/bps/article/670156>.

⁷ "Documents and Resources," Bureau of Planning and Sustainability, <https://www.portlandoregon.gov/bps/67730>.

Proposed Draft to Planning and Sustainability Commission

Comments received during the *Discussion Draft* public review period informed the *Proposed Draft*, which is staff's proposal to the Planning and Sustainability Commission (PSC). The *Proposed Draft* was posted on the project website on April 2, 2018—5 weeks before the PSC's first public hearing on May 8, 2018. As part of the *Proposed Draft* publication and legislative process requirements, the following legal notices were sent:

- **Form 1 Notice**
State notice sent to the Oregon Department of Land Conservation and Development
- **Legislative Notice** (~1,000 notices)
City notice sent to interested parties, recognized organizations, affected bureaus, TriMet, Metro and ODOT and published in the *Daily Journal of Commerce*
- **Measure 56 Notice** (~135,000 notices)
State Ballot Measure 56 notice sent to owners of each lot or parcel of property where there is a proposed change to the base zoning of the property or where there are limits or prohibition of land uses previously allowed in the affected zone.

In addition to these legal requirements, information about the PSC hearings was featured in blog posts on the project website, e-updates to project mailing list, media releases and posts by BPS on NextDoor, Twitter and Facebook.

The PSC received over 1,200 pieces of testimony on the *Proposed Draft* through mail, email, the Map App and verbally. Over 100 people testified in person during hearings held on May 8 and 15 and more than 40 letters from various organizations and neighborhood associations were received.

After the Planning and Sustainability Commission considered public testimony, they held a series of work sessions to consider and deliberate over suggested changes to the Proposed Draft. On September 11, the Commission gave staff direction to develop revised code and map proposals to reflect those changes. This *Revised Proposed Draft* incorporates those changes and will be reviewed by the PSC to ensure that the direction they provided staff through their deliberations and prior work sessions has been effectively incorporated into the proposal. Additional amendments may be introduced by the PSC before their final vote on a formal recommendation to City Council.

Recommended Draft to City Council

City Council is tentatively scheduled to hold public hearings on the PSC's *Recommended Draft* in the Summer of 2019. The public will be invited to testify on the PSC's proposals at that time.

Section 3: Summary of Amendments

On September 11th, 2018, following a series of work sessions over three months, the Planning and Sustainability Commission (PSC) directed staff to revise the Residential Infill Project proposals from the April 2018 Proposed Draft. The PSCs directed changes do the following:

- Increase the variety of available **housing options**, in more locations, while ensuring greater compatibility of **scale** of these buildings.
- Address and improve **building design** in Portland’s single-dwelling neighborhoods.

In response, the Bureau of Planning and Sustainability prepared the following revised proposals that build on existing base zone allowances. The amendments address the scale of infill development and how and where to increase the range of new infill housing options, including development on historically narrow lots. Additional detail and analysis of the 12 proposals is included in Section 4: Analysis of Amendments, noted by page number references below.

Housing Options and Scale

1. Allow for more housing types. *Page 12*
2. Limit the overall size of buildings. *Page 15*
3. For three or four units, at least one unit must be visitable. *Page 19*
4. Require at least two dwelling units when developing a vacant double-sized lot. *Page 21*
5. Rezone half of the historically narrow lots from R5 to R2.5. Allow the remainder of the historically narrow lots in the R5 zone to be confirmed for attached houses. *Page 23*
6. Allow small flag lots through property line adjustments. *Page 26*
7. Continue to allow added different building forms and site arrangements through a planned development review. *Page 27*

Building Design

8. Revise how height is measured. *Page 30*
9. Address building features and articulation. *Page 32*
10. Provide greater flexibility for ADU design. *Page 34*
11. Modify parking rules. *Page 35*
12. Improve building design on lots less than 32 feet wide. *Page 37*

Section 4: Analysis of Amendments

The goal of the Residential Infill Project is to update Portland’s single-dwelling zoning rules to better meet the changing housing needs of current and future residents.

- Portland is expected to grow by more than 100,000 households by 2035. About 20 percent of those units will be in single-dwelling neighborhoods. Still, two-thirds of our housing in 20 years will be the housing that exists today.
- The average age of city residents is increasing, yet most of our housing supply will not be able to meet the mobility needs of these older adults and will be a barrier to aging-in-community.
- The average number of people per household will continue to decrease, while the average new house size continues to increase.

The proposals in this report reflect key changes to the Zoning Code, Zoning Map and Comprehensive Plan Map in residential areas to address these trends by allowing for a wider range of housing types that can serve our growing and changing community. These proposals are intended to allow for a gradual transition to a more prosperous, healthy, equitable and resilient city.

Housing Options and Scale

The proposals create more opportunity for additional housing types on most of the single-dwelling lots in Portland, except those with natural resource or hazard constraints or those that do not have the infrastructure to support additional households.

The proposals result in:

- Greater consistency with the established Portland pattern of houses.
- Increased land-use and resource efficiency.
- Additional outdoor yard space and/or increased privacy and solar access for neighbors.
- Opportunities for smaller, less expensive houses.

1. Allow for more housing types.

Affects R7, R5 and R2.5 zoned properties; ADUs in all zones.

The proposal

- Allow for houses, duplexes, triplexes and fourplexes
- Allow a house to have two accessory dwelling units (ADUs) or a duplex to have one ADU
- Limit lots with the following constraints to a house plus one ADU, or a corner lot duplex:
 - 100-year floodplain
 - Areas identified in the natural resource inventory (NRI)
 - Landslide hazards
 - Unpaved streets
- Set a minimum lot size for lots with 1-2 units and a larger lot size for lots with 3-4 units.

For example:

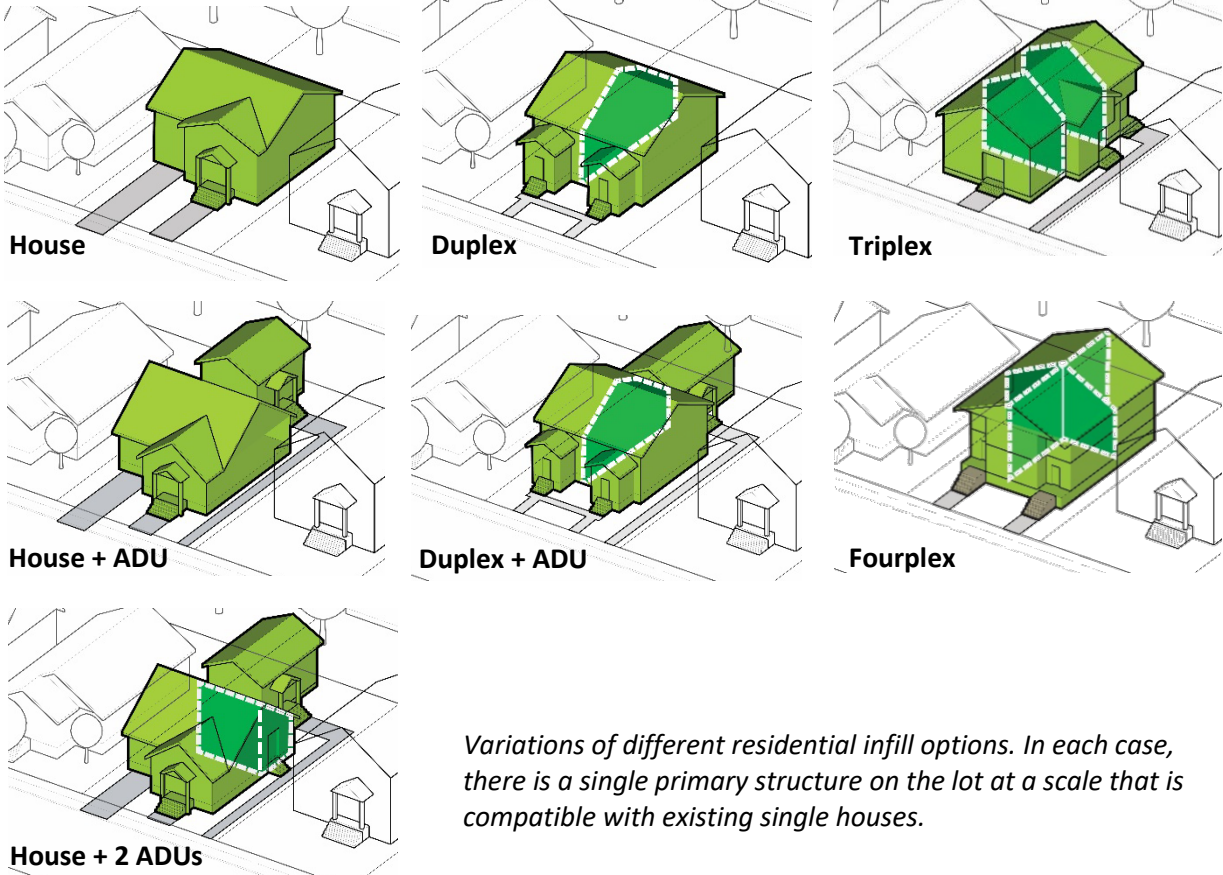

Variations of different residential infill options. In each case, there is a single primary structure on the lot at a scale that is compatible with existing single houses.

What is the intended benefit?

Portland is facing some tough choices about how to adapt to the changing housing needs of current and future residents. Home prices keep climbing and apartments are the predominant housing type being built (about 74 percent of units built in 2016). The additional housing types proposed offer **alternatives** to apartment buildings and single houses. In addition, many neighborhoods already have these housing types from past eras of development.

As the price of land for housing continues to climb, the ability for many households to gain entry into single-dwelling areas grows increasingly out of reach. Current zoning in nearly half of the city's land area limits development to a single house. To recoup the cost paid for the land, larger and therefore more expensive houses are built, or smaller houses are remodeled into larger houses. By providing alternatives that allow two, three or four units on a lot instead, suddenly a wider variety of housing options becomes possible. These units can be sold as condominium units at roughly **half the average cost of a single new house**. This opens opportunities for more middle-wage earners to find a foothold in the housing market and **avoid being priced out of neighborhoods** entirely. The proposed new housing options can help **increase the supply of housing and smaller units** in a way that fills a gap between single houses and apartment buildings.

The proposed housing options **use land and resources more efficiently**. Our current development trends are not keeping pace with our housing demands. While average household sizes have

declined in Portland from nearly 4.2 persons a century ago to about 2.3 persons today, the size of homes has increased from just over 1,000 square feet to 2,700 square feet today. Some neighborhoods are seeing additional new houses built, while simultaneously they are losing population. Smaller unit sizes are also more **energy-efficient** than a single unit twice the size.

What else about the proposal should I know?

Lots that only have frontage on **unpaved streets** would not be eligible to construct additional housing types. These streets are less accessible to bikes and pedestrians, and they require more frequent maintenance than paved streets. Additionally, unpaved streets are less likely to handle stormwater effectively. Lots on paved private streets would be eligible for additional housing types.

Landslide hazards are defined as areas that are subject to deep landslide susceptibility (slow moving, large soil volume), in the path of potentially rapid moving landslides (quick moving mudflow), or on historic landslide deposits and scarps. **Floodplains** include both the FEMA 100-year floodplain and the 1996 flood inundation area. Restricting housing options in these areas reduces the level of asset risk by reducing the number of households that are exposed to these risks.



Example of an unpaved street



Example of an active deep landslide

The additional housing types proposed would only be allowed on lots that meet the following **minimum lot sizes**. Larger lot sizes ensure that sites are big enough in conjunction with their associated FAR limits to accommodate reasonably sized units, plus provide suitable area for yards and any proposed parking.

Comparison of proposed FAR by zone on minimum sized lots with resulting average unit sizes*										
# of Units	Housing Type	R7			R5			R2.5		
		Min lot size	Base FAR	Average unit sizes	Min lot size	Base FAR	Average unit sizes	Min lot size	Base FAR	Average unit sizes
1	House	4,200	0.4	1,680	3,000	0.5	1,500	1,600	0.7	1,120
2	House + ADU, or Duplex		0.5	1,050		0.6	900		0.8	640
3	House + 2 ADUs Duplex + ADU, or Triplex	5,000	0.6	1,000	4,500	0.7	1,050	3,200	0.9	960
4	Fourplex			750						788

*Average unit sizes derived from: (lot size*FAR)/# of units. They do not reflect ADU unit size limits.

Houses may have up to two accessory dwelling units (ADUs). Both ADUs may be detached from the house or one may be attached to or internal to the house. A duplex may only have a detached ADU. In any case, three units in a single building is considered a triplex, including three attached townhouses.

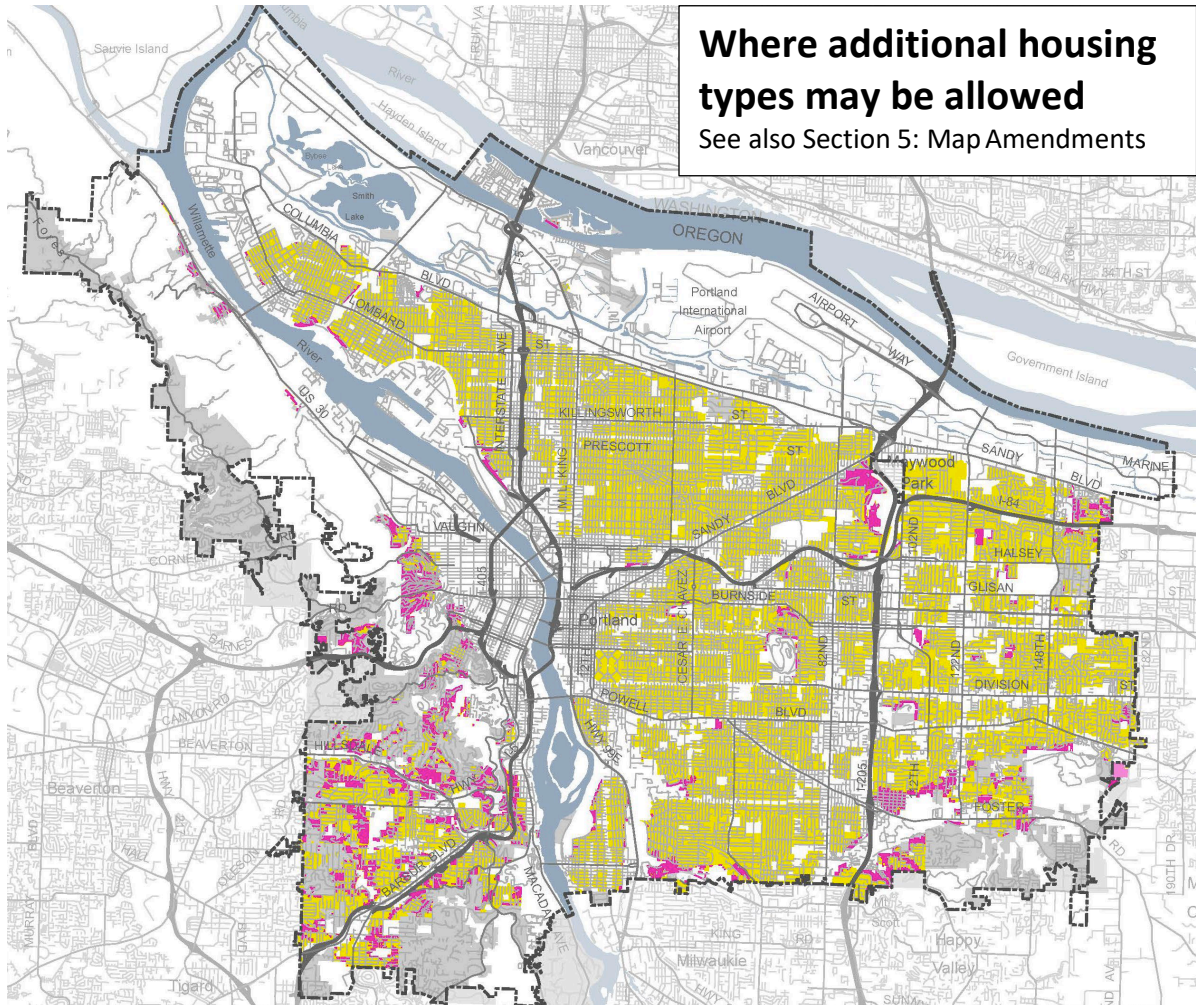

Areas in yellow indicate the R2.5, R5 and R7 zones that are proposed to allow the additional housing types. The magenta areas indicate natural hazard or resource constraints, and the gray areas indicate low-density RF, R20 and R10 zones. See Section 5: Map Amendments for more information.

2. Limit the overall size of buildings.

Affects R7, R5 and R2.5 zoned properties.

The proposal

- Set a total maximum building size, measured by floor-to-area ratio (FAR), that is less than what is achievable today.
- Scale the FAR to increase as the number of units increases on the site.
- Exclude attics and basements from FAR.
- Allow a bonus increase in FAR on the site if:
 - At least one of the units is affordable (80% median family income), or
 - Units are added to a site with an existing house and the street-facing facade of the house remains substantially unaltered.

For example:

On a 5,000 square foot lot in the R5 zone, the following building sizes would be possible.

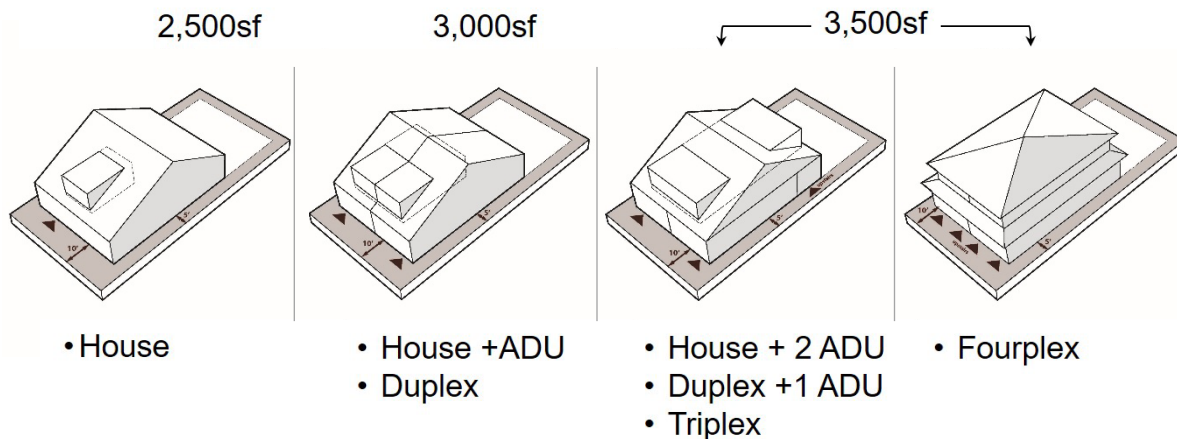

What is the intended benefit?

Using FAR is intended to **prevent disproportionately large buildings, while retaining flexibility** that does not create a barrier to new development or remodels.

Other approaches like reducing building coverage, lowering heights and increasing setbacks could be applied; however, they can excessively limit development of smaller lots, while still allowing overly large buildings on larger lots. FAR provides for a proportionate amount of square footage that is linked to lot size. How that square footage is allocated (either spread out or stacked up) remains flexible. Reducing building coverage alone encourages taller buildings. Combining height limits with building coverage limits creates a complicated set of rules that are less flexible for subsequent additions.

The proposed FARs have been set to **encourage, but not mandate, two-story buildings**. This can result in much lower building coverage than the maximum that is currently allowed.

For example:

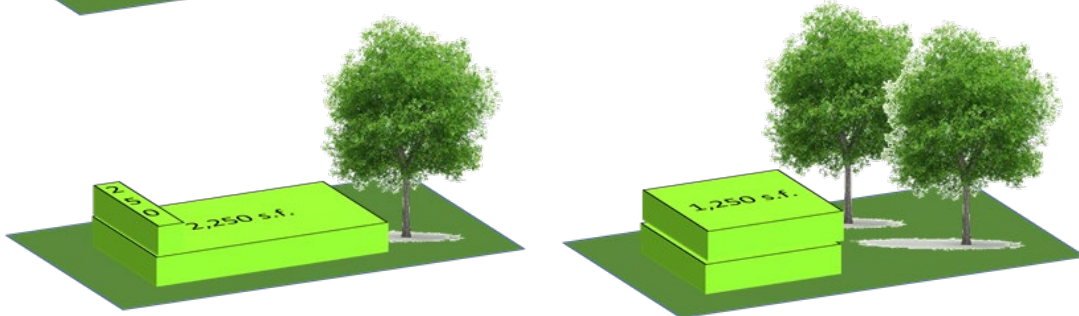

Proposed FAR creates a choice: spread out (45% coverage) or stack up (25% coverage).

	R7 – 7,000 square foot lot	R5 – 5,000 square foot lot	R2.5 – 2,500 square foot lot
Current Code maximum size* Based on building coverage and height limits	7,650 square feet <i>This is roughly 1.1 FAR.</i>	6,750 square feet <i>This is roughly 1.35 FAR.</i>	4,375 square feet <i>This is roughly 1.75 FAR.</i>
Proposed maximum size Base (one unit)	2,800 square feet <i>Maximum 0.4 FAR</i>	2,500 square feet <i>Maximum 0.5 FAR</i>	1,750 square feet <i>Maximum 0.7 FAR</i>
Maximum (three or four units with bonus FAR)	4,900 square feet <i>Maximum 0.7 FAR</i>	4,000 square feet <i>Maximum 0.8 FAR</i>	2,500 square feet <i>Maximum 1.0 FAR</i>
	R7 House Fourplex	R5 House Fourplex	R2.5 (5,000 sq. ft. lot) Duplex** Fourplex

* The current code maximum size is determined by calculating the building coverage and multiplying by the number of stories that can be built under the height limit. For example, for the R5, 5,000 square foot lot, the building coverage is 2,250 square feet, and the height is 30' (3 stories). Multiplying 2,250 times 3 yields 6,750 square feet of total allowable building area.

** In the R2.5 zone on a 5,000 sq. ft. lot, a minimum of 2 units is required (see proposal 4)

What else about the proposal should I know?

Detached accessory structures are included with primary structures in the total calculation of floor area allowed on the site. One FAR standard will apply to the entire site. This provides greater flexibility to have a larger or smaller accessory structure, depending on how much square footage is being used for the primary structure. To encourage ADU creation, additional FAR is provided when there is a second or third unit on the site.

The calculation of total floor area does not include basements (floors where at least 50 percent of the combined wall area is below grade) or portions of attics where the ceiling height is less than 80 inches (the minimum height required by the building code to be considered “habitable space”).

FAR is not an adjustable standard. Due to the inclusion of scaled FARs for two and three units as well as the incentives for affordable housing or converting existing home sites described below, an adjustment process would undermine and negate the benefits those provisions aim to achieve. To achieve additional base FAR, more units must be provided.

Bonus FAR may be obtained in one of two ways:

The first is by adding units to a site while **retaining an existing house or converting the house** to a duplex, triplex or fourplex. The front façade of the house must remain substantially unaltered to achieve this bonus FAR.

The other way to gain FAR is by meeting **affordability requirements**. When one unit is priced for those making up to 80 percent of the median income, then an additional 0.1 FAR can be achieved. This is designed to help make small, affordable infill-housing development projects more feasible by making more FAR available than what is allowed for market-rate housing projects and/or to better accommodate larger families in affordable housing.

The proposed FAR limits take into consideration the typical sizes of new and existing homes in neighborhoods. The first table below summarizes the average size of new houses built in 2015 by zone based on permit data. The second table shows the average size of existing houses by zone based on tax assessor data, which is the best citywide data available. This comparison shows that while many of the new houses being built today surpass the proposed FAR limits, most of the housing stock—older, existing houses—would fall within the proposed limits. The expected outcome of this proposal is new houses will be smaller than what is being built today and more comparable to existing houses.

2015 Houses	R2.5	R5	R7
Number of permits	99	275	51
Largest house size (square feet)	4,574	4,627	4,809
Largest FAR	1.32 to 1	1.27 to 1	.96 to 1
Average house size (square feet)	2,381	2,669	3,252
Average FAR	.75 to 1	.64 to 1	.47 to 1
Permits above the proposed FAR	51%	76%	59%
<i>Includes habitable area only, excluding low attics, garages and unfinished basements.</i>			
Existing Houses	R2.5	R5	R7
Number of houses	13,279	76,027	27,669
Average FAR	0.31 to 1	0.30 to 1	0.21 to 1
Number and percentage of houses that are nonconforming with proposed FAR	476 (3.5%)	9159 (12%)	1412 (5.1%)

Analyzing the risk of displacement

The 2035 Comprehensive Plan defines displacement as when households are involuntarily forced to move from a neighborhood because of increasing values, rents, or changes in the neighborhood's ability to meet their basic needs. **Policy 5.15, Gentrification/displacement risk**, requires new plans to evaluate the potential to cause displacement or increase housing costs in vulnerable communities. *Appendix H* presents the detailed displacement risk analysis summarized here.

Who is vulnerable to displacement?

Economic vulnerability is measured across four variables: households that rent, people who identify with a community of color, people without four-year degrees and low-income households. These socioeconomic factors indicate a reduced ability to withstand housing market price increases.

Displacement Risk Areas are census tracts that have a vulnerable population, have experienced demographic change and have housing market conditions with increasing prices. In addition to those geographic areas, **the analysis also focused specifically on the impact to the 14,000 low-income households who rent single-family homes**. These households are most vulnerable because they have the least control over their housing (they are subject to eviction) and limited choice in housing (based on affordability).

Where is redevelopment most likely?

Redevelopment occurs because a new building might be of higher value than an existing single-family house. In this situation, redevelopment could occur when a developer chooses to demolish an existing house to build a new structure with multiple units. The analysis evaluates two 2035 development scenarios: one for current zoning as the baseline scenario and one for the Residential Infill Project.

Overall, the project proposals are likely to **reduce displacement of low-income renters in single-family homes across Portland**. This reduction is the result of allowing more units to be built on one lot, which means there will be fewer lots redeveloped overall across Portland. Other key findings from the comparison between the baseline current zoning scenario and the proposal include:

- **Inner Portland neighborhoods** like Buckman, Richmond, Eliot, and Humboldt **see minimal change in redevelopment** rates and **moderate increases in housing** units.
- **Middle ring neighborhoods**, including St. Johns, Portsmouth, Concordia, Cully, Montavilla, Brentwood-Darlington and Lents, **see significant increases in new units**, but **lower rates of redevelopment**.
- **West Portland** neighborhoods see minimal change in redevelopment.
- **Most East Portland neighborhoods** see **moderate increases in new housing units** including Centennial, Powellhurst-Gilbert, Mill Park and eastern portions of Lents.
- Conversely, **some areas of Portland see decreases in redevelopment and new units**. These areas include neighborhoods such as Eastmoreland, Southwest Hills, Sylvan-Highlands, Hayhurst, Maplewood and Wilkes. In many cases **the cost to purchase existing houses exceeds the land price threshold necessary to support new development**.
- **Brentwood-Darlington, Lents**, and parts of the **Montavilla** neighborhood that are east of 82nd Avenue are likely to see significant increases in redevelopment that could also lead to the displacement of vulnerable households.

These findings suggest the Residential Infill Project will **reduce displacement of vulnerable households citywide (with some increases in certain areas), increase housing supply and choice and create less-expensive housing options** in Portland's single-dwelling zones.

3. For three or four units, at least one unit must be visitable.

Affects R7, R5 and R2.5 zoned properties.

The proposal

- For lots with three or four units, at least one unit on the site must meet the following visitability requirements:
 - No-step entry
 - Wider doorways
 - Living space and bathroom on the ground floor

There are exceptions for units that are added in an existing building (which can be difficult to remodel to meet visitability requirements), for very steeply sloping lots, or when the slope of the lot from the street to the front door makes this standard impractical.

What is the intended benefit?

The proposed additional housing options include **new “visitability” requirements** to increase the accessibility and resiliency of neighborhoods. These requirements:

- Add to the supply of housing with fewer barriers to people with mobility impairments (including elderly and disabled persons).
- Add housing options for people to stay in their neighborhoods as they age and downsize.
- Offer convenience to other users of all ages, who, for example, use strollers or bicycles.
- Help remove barriers that can lead to social isolation for those with mobility limitations.

As our population continues to live longer, the demographics of the city are also changing and will reflect a higher average age. According to the 2017 American Community Survey, over 36 percent of adults 75 years and older in Portland have an ambulatory disability. About 13 percent of adults between the ages of 65 and 75 and another 10.5 percent of persons under the age of 65 experience mobility issues. As we think about the future housing stock, it is important to think about ways this housing can be readily adapted to suit our changing needs.

Some of those adaptations are fairly straightforward and do not require structural changes, but other costlier and potentially infeasible barriers to overcome include removing steps leading into a home, providing adequate-width doorways, and ensuring there is a bathroom on the accessible floor.



Retrofitting existing development can require extensive and costly modifications.

To be “visitable,” a dwelling must have a zero-step entry, wider doors (34 inches minimum), a bathroom with adequate maneuvering area and an area to socialize (minimum 70-square-foot room) on the same floor as the bathroom and visitable entrance. The proposal to include minimum living space area on the accessible floor ensures that units do not simply include an entry with an interior landing, a half-bath and a stairway to the dwelling area of the house. This is intended as a

relatively low-cost but high-impact way to increase accessibility. It does not accomplish or cost the same as providing for full accessible living, but it does provide a platform for future home modifications that can be tailored to meet the specific needs of the occupant.

What else about the proposal should I know?

Certain situations are exempt from the visitability requirements due to the impracticalities of meeting the standards. For example, existing houses or accessory buildings are exempt because of their fixed set of conditions like the level of the entrance or interior room layouts. Grading to achieve a zero-step entry could negatively impact the building. Reconfiguring interior walls or adding bathrooms where there is no plumbing would likewise be challenging.

Additionally, lots that are very steep (20 percent average slope) or have a steep slope from the street to the front door would require extensive grading, which could add significant cost and potentially remove topographic characteristics that help define the street.

4. Require at least two dwelling units when new development is proposed on a double-sized lot.

Affects R7, R5 and R2.5 zoned properties.

The proposal

- When new development is proposed on lots that are twice the standard size lot for the zone, at least two units will be required.

What is the intended benefit?

Single-dwelling zones only require one dwelling unit on a site, regardless of the site size. Conversely, multi-dwelling zones require that minimum densities be met at the time of development. For example, on a 10,000-square-foot R1 multi-dwelling site, the maximum density is 1 unit per 1,000 square feet (or 10 units), while the minimum density is 1 unit per 1,450 square feet (or 7 units). This ensures that land allocated for certain levels of housing densities are achieving those levels.

In the R7, R5 and R2.5 zones, minimum densities are only ensured when lots are being divided. When new development is proposed, or when a house is demolished on a double-sized or larger lot, current rules allow just a single house to be built. This is an issue in the R2.5 zone where almost 40 percent of the lots are at least double the required average lot size. While this situation applies to fewer than 10 percent of the lots in the R7 and R5 zones, without this provision, a single large house (5,000-square-foot house on a 10,000-square-foot lot in the R5) could be built and would be a lost opportunity for adding housing.

What else about the proposal should I know?

The two dwelling-unit requirement only applies to new development sites and does not apply to lots that have an existing house when additions are proposed. The requirement does not require that large lots be divided. It can be met with a house plus an accessory dwelling unit (ADU), or a duplex on sites where duplexes are allowed. Most lots in these zones will also allow for duplexes, and all corner lots currently permit duplexes.

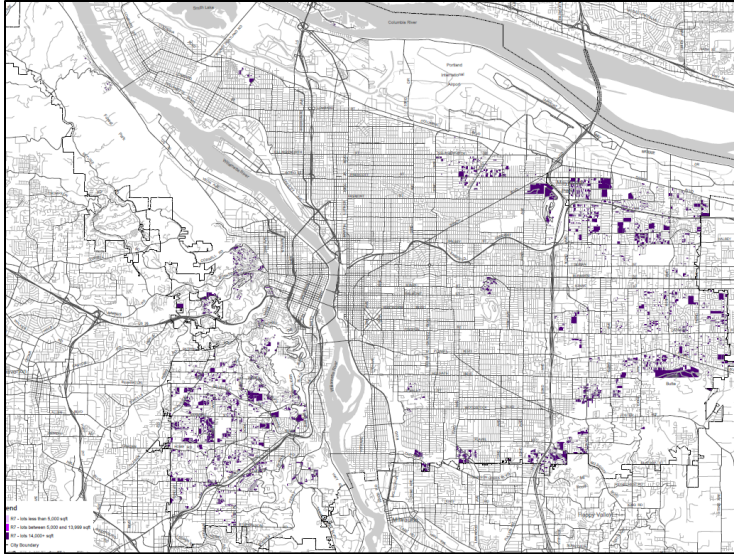

R7

All lots:
32,953

Lots 14,000 sq. ft. and larger:
2,812 (8.5%)

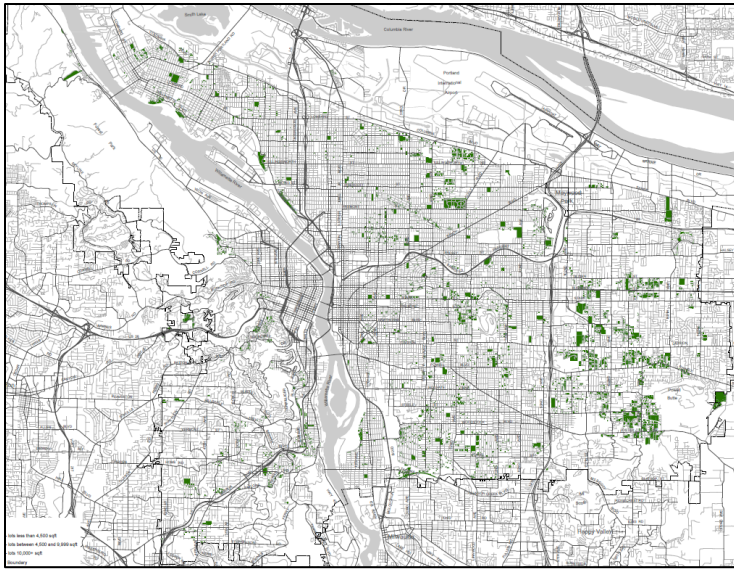

R5

All lots:
73,557

Lots 10,000 sq. ft. and larger:
4,629 (6.3%)

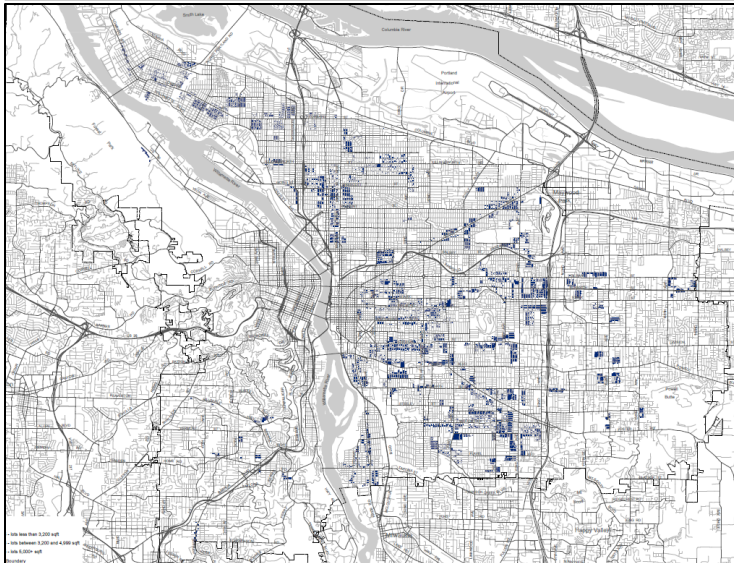

R2.5

All lots:
26,675

5,000 sq. ft. and larger:
10,614 (39.8%)

5. Rezone half of the historically narrow lots from R5 to R2.5. Allow the remainder of the historically narrow lots in the R5 zone to be built with pairs of attached houses.

Affects Historically narrow lots in the R5 zone.

The proposal

- Rezone historically narrow lots that have the highest access to amenities from R5 to R2.5.
- For the remaining historically narrow lots zoned R5 citywide, allow these lots to be developed with attached houses that can be owned separately.

Summary of Lots and Area Proposed for Rezoning		
Citywide Statistics	Lots	Acres
R5 historically narrow lots	14,435	1,804
R5 to R2.5 Rezoning		
R5 Historically narrow lots	6,384	742
Other R5 rezones (not historically narrow lots)	324	40
Total properties rezoned to R2.5	6,708	782

What is the intended benefit?

Some areas of the city have original, **underlying platting that created lots smaller than typical for the current zoning**. These are referred to as “historically narrow lots.” Most of these areas are in R5 zones. A typical R5-zoned property is 50 feet wide by 100 feet deep (5,000 square feet). A typical R5 “historically narrow lot” is 25 feet wide by 100 feet deep (2,500 square feet). The platting pattern and the concentration of historically narrow lots in certain areas of the city predates modern zoning and their location is an artifact of history.

Current rules in the single dwelling zones allow development on any legally-created property that meets the minimum lot size and is at least 36 feet wide. Current rules in the R5 zone also allow development on sites that do not meet the minimum lot dimension standards if the lot has been vacant for five years. This applies to historically narrow lots. While the “vacant lot provision” has probably prevented some demolitions, it has also led to confusion about the zoning pattern and what is allowed and what is not. This issue is sometimes called the “five-year moratorium.” For more information about historically narrow lots, see *Appendix G: Portland’s Historically Narrow Lots*.

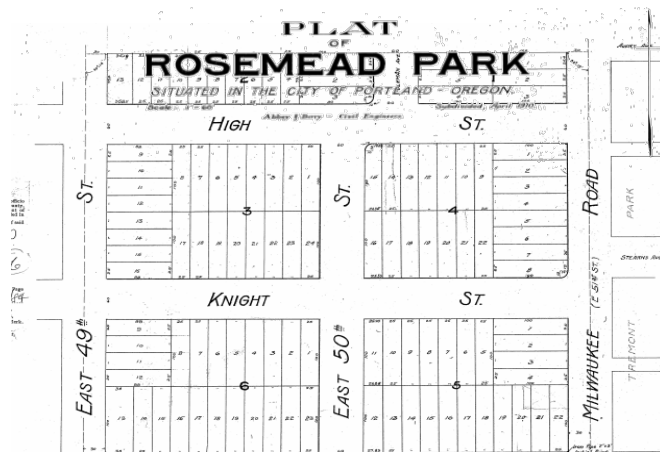

Plat for Rosemead Park, filed 1910. The lots in this plat are 25 feet wide, with varying lot depths.

Rezoning some historically narrow lots to R2.5 is **consistent with Comprehensive Plan** Policy 10.1, which states that the R2.5 Single-Dwelling – 2,500 designation:

“allows a mix of housing types that are single-dwelling in character. This designation is intended for areas near, in, and along centers and corridors, near transit station areas, where urban public services, generally including complete local street networks and access to frequent transit, are available or planned. Areas within this designation generally do not have development constraints. This designation often serves as a transition between mixed use or multi-dwelling designations and lower density single dwelling designations. The maximum density is generally 17.4 lots per acre. The corresponding zone is R2.5.”

There are challenges to addressing historically narrow lots, but there are opportunities too:

Rezoning Some Historically Narrow Lots to R2.5	
Opportunities	Challenges
<ul style="list-style-type: none"> • Rezoning approach is transparent and consistent with lot size and density • Increases supply of lots for housing in the right places • Increases opportunities for fee-simple homeownership • Smaller homes and lots can be less expensive • Promotes smaller, more energy-efficient houses 	<ul style="list-style-type: none"> • Locations of historically narrow lots are not distributed evenly throughout the city • Increases demolition pressures in some neighborhoods • Narrow houses often do not reflect neighborhood character of houses built on wider lots • Multiple driveways eliminate on-street parking opportunities

The rezoning **increases the potential supply of housing in amenity-rich areas**, as called for in the Comprehensive Plan. The rezoning is based on their proximity to centers, parks, schools and other community amenities as well as consistent zoning designations and patterns of development.

The proposal provides the opportunity for a different housing type in the R5 zone—**fee-simple attached houses**. Fee-simple ownership is the most common ownership type in single-dwelling neighborhoods. It differs from condominium ownership in that the land under the house is owned by one owner, instead of being owned in common. Also, since these lots already exist, more costly land divisions would not be required to provide these fee-simple lots.

What else about the proposal should I know?

On the historically narrow lots that will remain zoned R5, the “five-year moratorium” will no longer apply and the underlying lots can be developed when attached houses are proposed. A key distinction between R2.5 and R5 lots is the allowable scale of houses. In the R2.5 zone at 0.7 FAR, each attached house would be up to 1,750 square feet, whereas the lower FAR of 0.5 in the R5 zone limits the maximum size of each attached house to 1,250 square feet. Another distinction is that the R5 zone only allows pairs of attached houses, as opposed to structures with multiple attached rowhouses (up to eight) in the R2.5 zone.

Exceptions would still allow developing detached houses on individual substandard R5 lots. For example, lots wider than 25 feet will permit a detached house. Also, if a detached house is already

built on a 25-foot-wide lot, the house may be rebuilt if accidentally damaged or destroyed. Lastly, if there is existing development on both lots adjacent to a historically narrow lot, that stand-alone lot would be allowed to be built with a detached house, since attaching to existing development on the other lot would be impractical.

Individual historically narrow lots are too small to qualify for the additional housing types described in Proposal 1, so it is not possible to put a triplex or fourplex on these lots. Where two or more substandard lots are combined to meet the minimum lot dimension requirements, this combination of lots could qualify for the additional housing types.

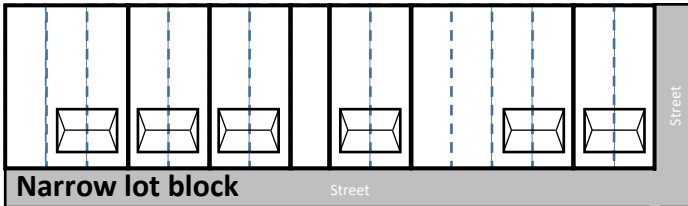

Existing historically narrow lots

This shows an example R5 zoned block with seven tax lots (solid lines) and 16 historically narrow lots (dashed lines).

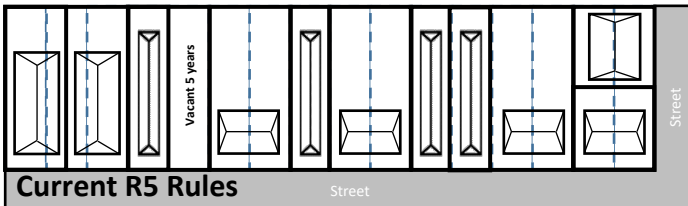

R5 - Current infill potential

Under current rules: • Property lines can be adjusted from three lots to create two 36'+ wide lots. • A house can be built on one lot, leaving the other lot vacant for five years. • The stand-alone lot can be built. • Skinny detached houses can be built on vacant lots. The corner lot can rotate the property line for detached houses.

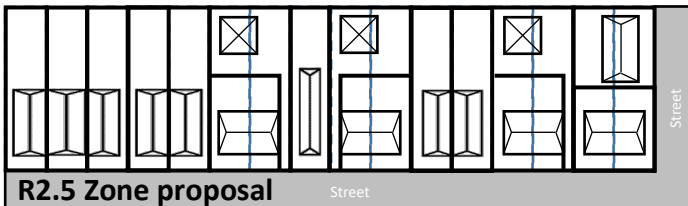

R2.5/R5 - Proposed infill potential

Historically narrow lots will have more infill opportunities: • Houses in R2.5 will have a max 0.7 FAR, while houses in R5 will have a max 0.5 FAR. • Attached houses will be required on narrow lots. In R5, only pairs of attached houses will be allowed. • Flag lots will be allowed through property line adjustments when an existing house is kept. • Stand-alone lots can be built. • Corner lots can rotate property lines for detached houses (R2.5) or attached houses (R5).

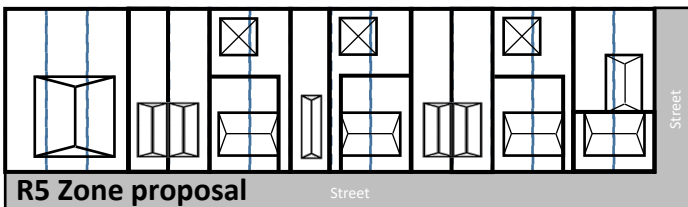

Some small pockets of R5-zoned areas that did not include historically narrow lots have been included in the R2.5 rezone proposal (324 lots, 40 acres) to provide for a transition between existing higher-intensity zones and the proposed rezone areas.

For more information about the criteria used and the location of proposed zone changes, see Section 5: Map Amendments and Appendix F: R2.5 Zone Changes by District.

6. Allow small flag lots through property line adjustments.

Affects R2.5 zones and historically narrow lots in the R5 zone.

The proposal

- Require that the existing house be retained and exempt from FAR limits at the time of the property line adjustment review.
- In the R5 zone, limit the height of the house on the flag lot to 20 feet, limit its size to 1,000 square feet and require additional exterior design elements.

What is the intended benefit?

The proposal allows for a small flag lot to be created either through a property line adjustment (R5 historically narrow lots and other R2.5 lots) or with a land division (R2.5 zones only). In general, flag lots are a less desirable form of development because the lots are disconnected from the public street. Because they are behind an existing house, they are also located next to the back yards of adjacent houses. On the other hand, flag lots afford infill opportunities while retaining existing houses⁸.

A property line adjustment process is quicker and less costly than a land division. This streamlined review process supports the creation of more fee-simple homeownership opportunities with smaller, less expensive units and provides homeowners the opportunity to capitalize on their investment. The provision encourages the preservation of a house by allowing this process and lot configuration only if a house is retained.

For example:

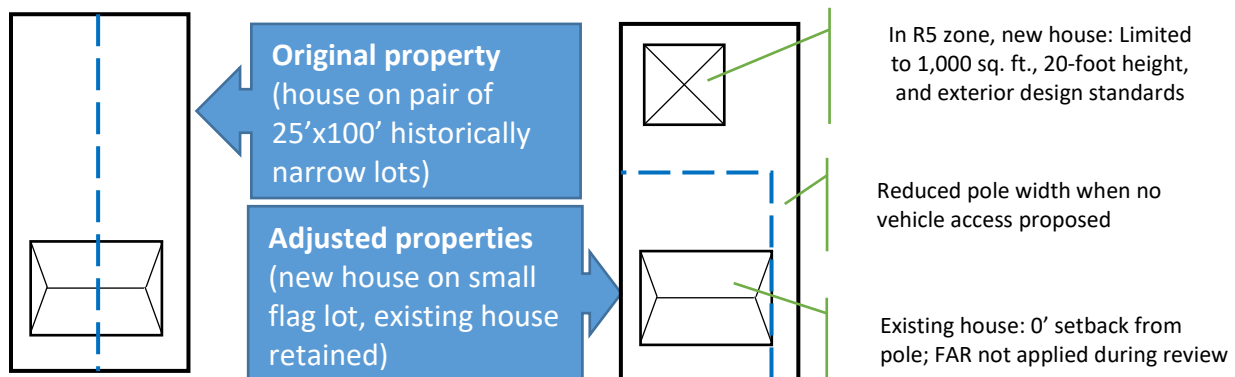

⁸ Staff estimates that in proposed rezone areas, less than 10 percent of historically narrow lots are vacant, while the proportion of lots with flag lot potential is closer to 20 percent.

What else about the proposal should I know?

To provide additional incentives to retain the existing house, the FAR for the existing house will not be reviewed during the flag lot property line adjustment request. Normally, when evaluating property line adjustment requests, the applicable development standards are evaluated to ensure that development remains in compliance. For example, if minimum setbacks or building coverage cannot be met as a result of changing the lot configuration, a land use adjustment is required. Exempting the FAR during a flag lot property line adjustment removes another potential barrier to keeping the existing house.



This image shows how a flag lot created through a property line adjustment could accommodate a small house.

In the R5 zone, additional limitations are proposed on the flag lot to maintain a more conventional pattern of primary structures along the street with smaller detached structures in the back yard. To achieve this, the flag lot house will be limited in size (1,000 square feet) and height (20 feet), and exterior design requirements (similar to what is required for accessory structures taller than 15 feet) will apply.

7. Continue to allow different building forms and site arrangements through a planned development review.

Affects R7, R5 and R2.5 zoned properties.

The proposal

- Align the review procedure, allowable density, and development standards for similarly sized planned developments and land division sites.

What is the intended benefit?

Cottage clusters are groups of relatively small homes that are typically oriented around a shared common space such as a courtyard or garden. Parking is often relegated to the edge of the site. These clustered developments foster a sense of community among residents and can be modeled to suit many specific living needs. The units could be part of a cohousing project, tailored to older adults or people with disabilities or built with other innovative attributes.

Planned Development (PD) is the type of review process used for new cottage cluster projects. The primary difference between a cottage cluster PD and a standard subdivision is the lack of individual lots. Some or all the cottage cluster units share a lot.

The PD review enables the flexibility needed by cottage clusters to respond to site characteristics, constraints and opportunities. Because a cottage cluster is a break from the standard lot pattern, these proposals are reviewed for their site layout and architecture to ensure compatibility with the surrounding neighborhood.



For example: Smaller homes clustered around a common open space in Northwest Heights.

The proposal accomplishes **four key objectives**:

1. It allows for similar densities that would be allowed through a standard subdivision.
2. It more closely aligns the type of review procedure with subdivisions proposing the same number of units.
3. It retains flexibility that allows more types of housing, site layout and building design while ensuring compatibility with the neighborhood through a discretionary review process and providing certainty in the subsequent phases of development through a land use approval.
4. It provides the opportunity for community members to receive public notice and comment on the PD proposal.

4-lot land division

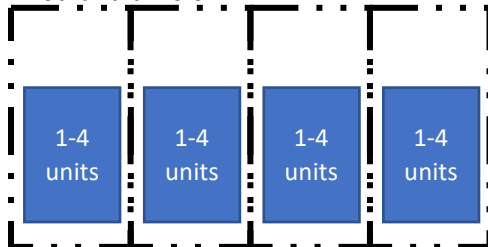

Single lot planned development

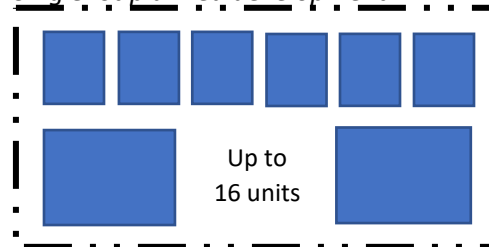

In a standard land division of a 20,000 square foot R5 zoned property into four lots, each could include between 1 and 4 units (house through fourplex). A planned development would allow the same number of units but with greater flexibility in how they are arranged on the site and would be reviewed for context and compatibility during the review. Both would be reviewed through the same review procedure type (Type IIx).

<i>Comparison of Planned Development and Land Division reviews on a 20,000-square-foot R5 site</i>			
	Land Division	Current PD (no LD)	Proposed PD (no LD)
Review Type	IIx	III	IIx
Number of lots	4	1	1
Total number of units	Up to 16 (4 plex x 4 lots)	4 (20,000 ÷ 5,000 sq. ft.)	Up to 16
FAR	4 Houses=0.5 4 Duplexes=0.6 4 Triplex/fourplex=0.7	N/A	0.7
Building coverage	45% per lot (average)	22.5%	22.5% but modifiable
Visitability	1 per triplex/fourplex	N/A	33% of units

What else about the proposal should I know?

Planned developments allow for cottage cluster-style developments, but they also provide the flexibility for other types of housing arrangements, too. This might include garden apartments, courtyard housing, or other combinations of houses, duplexes and triplexes. The proposal is not specific to cottage clusters but rather allows for greater alignment with land division sites in terms of numbers of units, building sizes and review procedures on sites where the land is not being divided into multiple lots.

In the R5 and R7 zones, the allowable units for a planned development site is four times the potential number of lots. However, in the R2.5 zone, the allowable density is just two times the number of potential lots, in part due to the difference between larger lot size required for three or four units (3,200 square feet) as opposed to the underlying lot density (one lot per 2,500 square feet).

Land use review procedures, in order from least to greatest level of process, include Type I and Ix, Type II and IIx, Type III and Type IV. Most PDs currently go through a Type III procedure, which is decided by a Hearings Officer and, if appealed, by City Council. By comparison, a Type IIx land use review, which applies to smaller land divisions, is less expensive, requires less time to process and is a staff decision that can be appealed to the Hearings Officer. Both procedure types utilize the same approval criteria and provide opportunities for appeals at both the City and State level.

The proposal changes the threshold for PDs so that proposals up to 20 units are processed as a Type IIx case, the same maximum number of units that can be reviewed through a Type IIx standard R2.5 subdivision (10 lots with two units each). Any proposal in a single-dwelling zone that includes commercial or multi-dwelling structures (structures containing five or more units), regardless of the number of units being proposed, remains a Type III review procedure.

Building Design

The proposals seek to improve building design, resulting in:

- Building heights that better relate to the site
- Improved roof articulation and front setback alignment
- Reduced impacts from onsite driveways and garages
- Houses on narrow lots that are more consistent with homes on wider lots

8. Revise how height is measured.

Affects All zones, including non-residential zones.

The proposal

- Measure height from the *lowest* point near the house, not the *highest* point.
- Clarify that small dormers are excluded from the height measurement.
- Continue to allow 2½ story houses (30 feet high) on standard lots.

What is the intended benefit?

This change limits the ability to artificially elevate the reference point to obtain a taller structure. It also limits the ability to use dormers to fully extend an additional floor (see examples below).

The revised height measurement method ensures that structures have a **better relationship to the public street and sidewalk**. Lots that slope up from the street currently may allow for a full additional floor when viewed at the street. Lots that steeply slope down from the street will continue to have an alternative method that allows for 23 feet of height above the street elevation. The net effects of the change are lower rooflines and facades that do not tower over the street.

The current height measurement uses the highest point near the house as the base point and measures to the midpoint of the sloped roof. On sloping sites, this can result in houses that exceed 2½ stories. Moreover, retaining walls and fill can be used to artificially elevate one part of the site to obtain a higher base point measurement. By measuring height from the lowest point, it becomes more difficult to artificially raise the height reference point. The entire area around the house would need to be raised (as opposed to the current method, where only a single raised point can establish the base reference point).

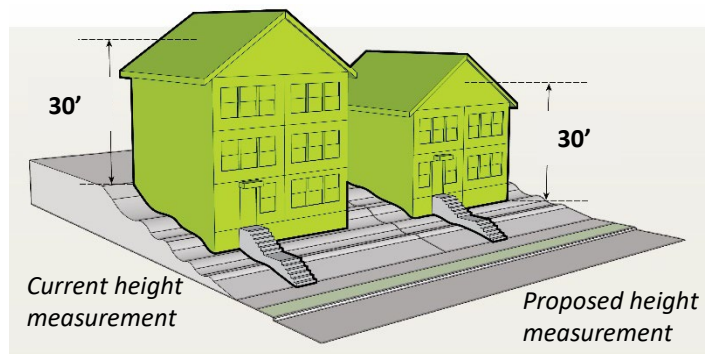

Dormers (which are often not measured under current code and frequently have a higher roof) would be measured for height unless they maintain a minimum 3:1 pitch, are set back from exterior

walls by 1 foot, do not project above the roof ridgeline and are less than 75 percent of the width of the roof they are on.

For example:

Currently, dormers are not included in height measurements.

The changes would include dormers in height measurements unless they met specific limits.



pro.homeadvisor.com



finehomebuilding.com

What else about the proposal should I know?

Since the height measurement is taken along a perimeter that sits 5 feet away from the edge of the building, window wells and exterior stairs to basements would not affect the new height measurement, provided they fall inside the 5-foot perimeter distance. In addition, a 5-foot-wide pedestrian access would be allowed through the perimeter without affecting the measured height. This provides for access to basement units, for example, on raised lots.

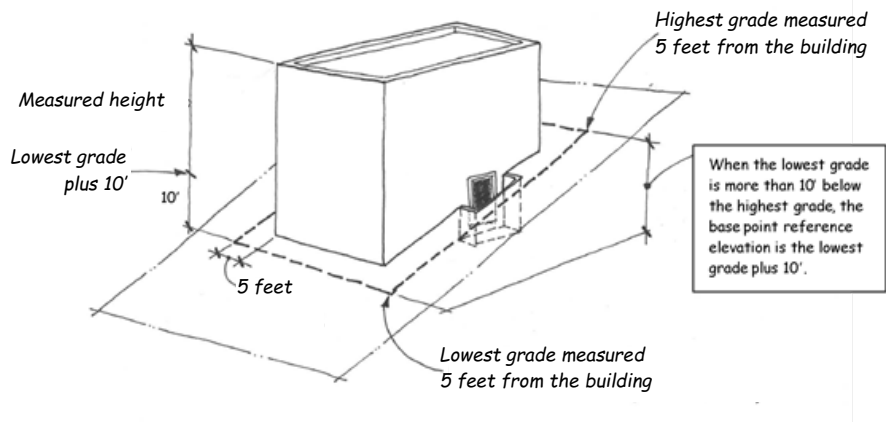

The current code differentiates measurement methods between gable roofs with less than 12:12 pitch (measure to the midpoint) from those with 12:12 and greater roof pitch (measure to the peak). The code also measures to the peak of pyramidal shaped roofs, even though the distinction between these and gable/hipped roofs is nearly imperceptible from the ground.

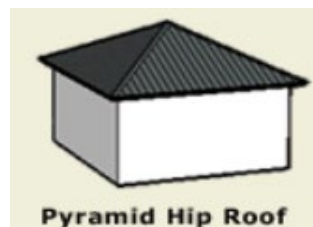
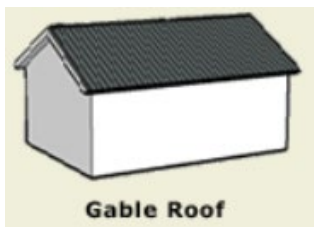

The proposed changes would treat these roof types the same by measuring to the midpoint in both cases, consistent with building code methodology. This allows for steeper pitched roofs that may be taller, but the building profile is typically less bulky than buildings with lower-pitched roofs. This will work together with FAR limits that count tall attic spaces to reduce the overall building bulk.

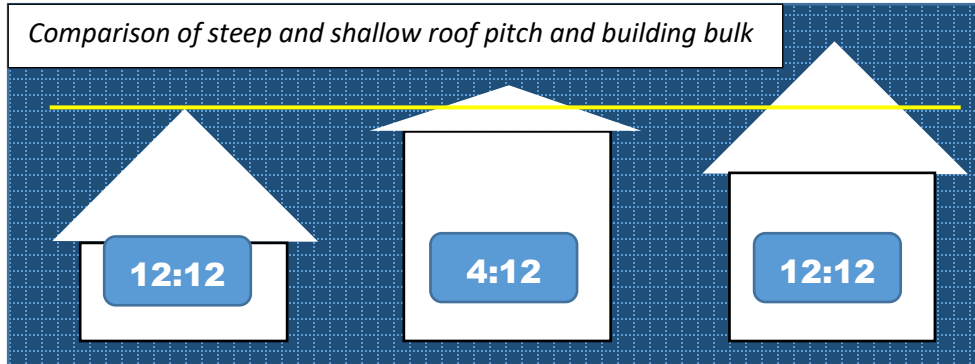

9. Address building features and articulation.

Affects R20, R10, R7, R5 and R2.5 zoned properties.

The proposal

- Limit how high the front door can be above the ground (R10 – R2.5 zones).
- Allow eaves to project up to 2 feet into setbacks (R20 – R2.5 zones).
- Allow the front door of each corner lot duplex unit to face the same street (R20 – R2.5 zones).

What is the intended benefit?

Limiting the height that the front door can be above grade reduces the number of stairs needed to get into a house and ensures that the first level of the house is kept closer to the surrounding grade. This helps to better “anchor” the house and **visually reduces the apparent height** of the structure. It also helps provide a more approachable and less foreboding front door while maintaining the appearance of a conventional single-dwelling structure, and it prevents the façade from being obscured by stairs.

In zones with a required side yard setback of 5 feet, eaves may only project 1 foot into the setback under current rules. Taller, wider houses look and fit better with wider eaves. In addition to **better proportioned buildings**, wider eaves also afford better **protection from sun and rain**.

For example:



Front doors are positioned closer to the ground and both oriented to the same street. Larger eaves better complement the roof.



Tall flights of stairs to raised front doors will no longer be allowed. Increased allowances for eave projections will enable wider eaves to be built.

Current rules require that corner lot duplexes have their front doors and addressing oriented to opposing streets. Removing this limitation provides **greater flexibility for duplex design** and can increase neighbor interaction and strengthen street identity.

What else about the proposal should I know?

The limitation on the height of front stairs does not apply to sites in the 100-year floodplain, where building code requirements mandate that the finished floor level be a certain distance above the 100-year flood elevation. In some cases, the limitation on how far above grade the front door can be could create conflicts with floodplain regulations.

This proposal also includes changes to how eaves are factored into building coverage calculations. Current code exempts eaves of any size from building coverage calculations. As long as a roof projection is cantilevered and not supported by posts, it is considered an eave. Consequently, very large eaves do not count toward building coverage limits. The proposed change to the definition of building coverage will now only exclude eaves that are up to 2 feet deep.

10. Provide greater flexibility for ADU design

Affects Accessory dwelling units (ADUs) in all zones.

The proposal

- Maintain current ADU allowances (living area).
- Allow basement ADU conversions to exceed the 800 sq. ft./75% size cap in an existing house.
- Allow the front door of an internal ADU to face the street.

What is the intended benefit?

Accessory dwelling units have gained popularity in Portland in recent years. They represent an excellent way to provide smaller housing choices and alternatives to apartments while also offering homeowners a way to supplement their income. They provide flexible options for extended family or others while maintaining a greater degree of autonomy than more traditional roommate situations. The current ADU allowances have been in effect for several years and have not placed undue barriers to ADU development. The proposed refinements are intended to further facilitate their creation.

Proposed **accessory dwelling units in basements** will have greater flexibility in size. Current code limits an ADU to 800 square feet or 75 percent of the primary dwelling unit size. In cases where a basement is being converted, the basement may either be slightly larger than the 800 square feet allowed, or the house may have just a single level above the basement meaning the ADU exceeds the 75 percent proportion limit. When this is the case, sections of the basement must be walled off as inaccessible, area must be designed for common use between both units, or an adjustment to the standards is required. To create added incentive to retain existing houses and promote additional ADUs, the size restrictions would not apply for converting a basement into an ADU provided that the entire ADU is in the basement and the home is at least five years old.



Example: Basement ADU

Removing the limitation that restricts having the front door of an accessory dwelling unit on the same façade as the main house will also provide more design options for internal ADUs or greater flexibility to convert space in an existing house to an ADU, such as a garage conversion.

What else about the proposal should I know?

Additional clarification is being added to the code to better differentiate “attached accessory structures” (built inside or alongside a primary structure), “connected accessory structures” (built separate from a primary structure but attached via a breezeway or deck), and “detached accessory structures” (built apart from and not connected to the primary structure). This is intended to more clearly specify that height, building coverage, and design standards for ADUs that are connected by a breezeway are the same as detached ADUs. Connected structures will need to meet base zone setbacks. The connection (e.g., breezeway) is subject to base zone height, building coverage and setback standards.

11. Modify parking rules

Affects Parking for houses, duplexes, triplexes and fourplexes in all zones.

The proposal

- Delete minimum parking requirements for residential uses (RF-R2.5 zones only).
- If a lot abuts an alley, require parking access to be from the alley when parking is provided. (Houses, duplexes, triplexes in all zones, and fourplexes on sites less than 7,500 sq. ft. in single dwelling and multi dwelling zones)
- Prohibit driveways and parking between the building and the street unless the driveway accesses a garage or parking space behind the front of the building. Limit garages to 50% of the building façade. Do not allow garages on facades less than 22' wide. (Attached houses, duplexes, triplexes and fourplexes in RF-R2.5 zones)

What is the intended benefit?

Removing parking requirements for residential uses provides the opportunity to reduce the amount of lot area used for pavement and provides more space for yards and trees. It also offers greater flexibility to site housing and reduces costs when on-site parking is not provided. Further, it promotes preserving on-street parking spaces that could be lost to driveways and curb cuts.

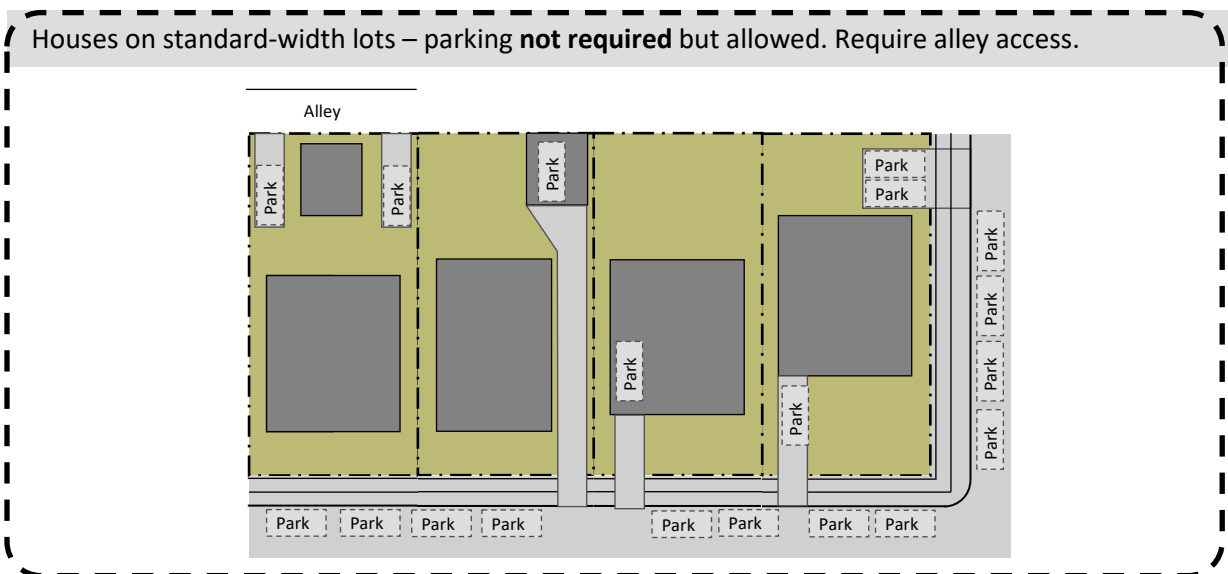

Alley-loaded parking is an optimal parking solution where alleys are present. It preserves the front yard landscaping, retains more area for street trees, eliminates curb cuts and reduces conflicts with pedestrians. However, requiring alley access has been problematic in some cases where the condition of the alley is unimproved, or where there are multiple encroachments (e.g., sheds, gardens, fences). The proposals strike a balance by requiring alley access for vehicles when the lot abuts an alley but not requiring parking to account for those cases when it may be impractical to use or improve the alley.

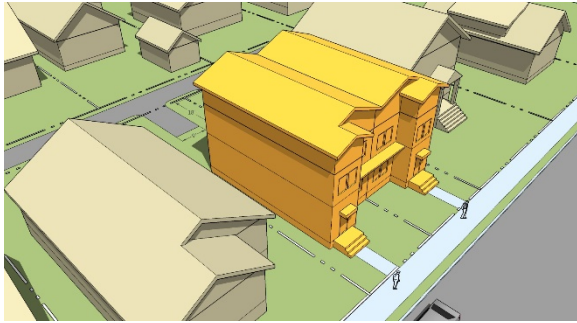

If a lot abuts an alley, then parking may be provided, but it must be accessed from the alley.



Wider building facades (22 feet or wider) would be allowed to have a garage.

Narrow lots present unique challenges for accommodating parking. First, their narrow width means that there is already limited curb space for on-street parking, and each driveway curb cut removes 15 feet of curb (9-foot-wide driveway with 3-foot aprons on each side). This essentially removes one on-street parking space for an off-street space. A series of narrow lots with driveways can effectively eliminate on-street parking opportunities on that side of the street entirely.

Secondly, the narrow width of the front façade of a detached house means that nearly 80 percent of the first floor facing the street is a garage. Attached houses fare slightly better at 60 percent. Current rules limit garages on most lots to 50 percent of the width of the house to **lessen the garage prominence** and **maintain a stronger connection between the living area of the house and the public realm**. When a building is at least 22 feet wide (e.g., a detached house on a 32-foot-wide lot), a garage may be built.

Currently, parking is not required for historically narrow lots, yet a 12-foot-wide garage is allowed. Narrow lots created more recently through a land division are required to have parking, but garages are not allowed, and alley access is required where alleys are present. The proposal combines these requirements so that parking is not required, and vehicle areas and parking are prohibited between the front building line and the street. Garages are limited based on the combined width of the building facades. On lots that abut an alley, parking access from the alley will continue to be required. For other lots, parking located behind the front building line will be allowed.

Narrow lots with attached houses, duplexes, triplexes, fourplexes – parking not required, and prohibited between the building and the street.

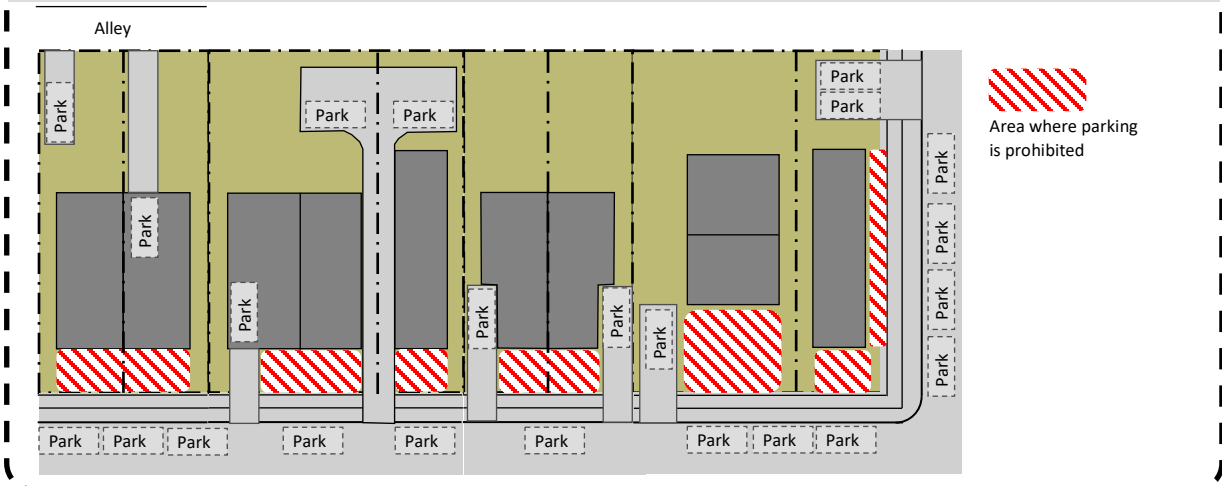

12. Improve building design for all narrow lots.

Affects Any lot less than 32 feet wide (R2.5 zone and historically narrow lots in R5 zone)

The proposal

For development on lots less than 32 feet wide:

- Apply a single set of rules to narrow lots.
- Limit height of a detached house to 1½ times its width.
- Require attached houses on lots 25 feet wide or narrower.
- Require landscaped front yards.
- Allow narrower lots for attached houses in the R2.5 zone.

For example:



Tall, detached narrow houses are discouraged, and front-loaded garages are prohibited on narrow facades.



The proposal requires attached houses with landscaping and other design elements to ensure façade reads as a single building.

What is the intended benefit?

These improvements are intended to enhance the development outcomes on narrow lots. They include some streamlining and consolidation of rules to treat similar lot sizes the same and require building forms that are more consistent with established neighborhood patterns.

Consolidated rules. There are several sets of requirements that currently apply to narrow lots, depending on the date the lot was created. The proposed rules consolidate and update these requirements into one set of narrow lot rules, improving consistency and reducing confusion about development outcomes on lots with similar dimensions and zoning.

Height limit. Narrow facades tend to accentuate vertical proportions and appear taller. Establishing a relationship of building height to building width helps control these proportions and prevent buildings from looking incompatibly taller.

Front landscaping. These standards help soften the appearance of houses on narrow lots and make them look more established by ensuring that new development provides landscaping along the front foundation wall and front yard.

Attached houses. A significant proposed change is the requirement for attached houses when the lots are 25 feet wide and narrower. Attached houses provide wider floorplates (typically 20 feet each versus 15 feet) and their combined width better mirrors the width of more common wider house facades. They are also more energy-efficient and require less material than detached houses. By attaching the houses instead of leaving small side yard setbacks, coupled with the FAR limits on house size, the resulting houses will tend to be less deep than detached houses (e.g., 43 feet versus 58 feet), leaving more useable backyard space (e.g., 46 feet versus 32 feet).

What else about the proposal should I know?

Exceptions for the attached house requirement acknowledge that stand-alone narrow lots exist or that in some cases existing development on the abutting lots may make attached houses impractical.

The current rules for narrow lots allow exceptions through either Design review, Planned Development review or Adjustment review. The proposed change consolidates these into one land use review type: Adjustment review. The Adjustment review evaluates how a proposal will equally or better meet the purpose of the requirement being adjusted, ensures that the proposal will not significantly detract from the livability or appearance of the residential area, and requires that any impacts are mitigated.

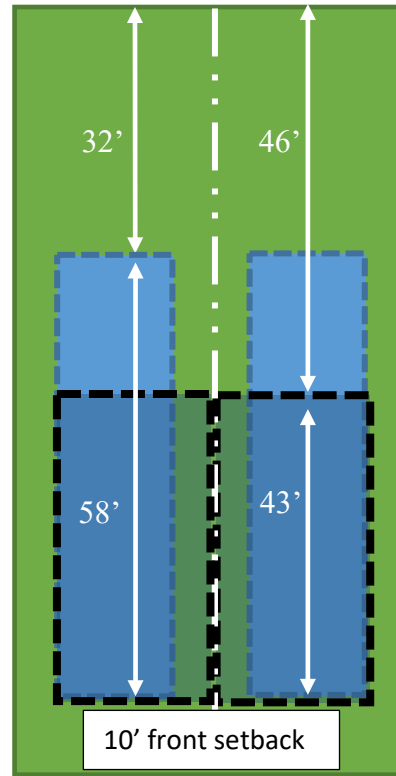

Comparison of back yard space between attached houses and detached houses on pairs of narrow lots

Lot width in the R2.5 zone. Current rules require new lots in the R2.5 zone to be at least 36 feet wide, unless an exception can be justified. This can be difficult for dividing lots that are 50 feet wide and makes it more difficult to retain an existing house on a site. Reducing the minimum width to 21

Reduced lot widths in the R2.5 zone will allow for additional attached houses.

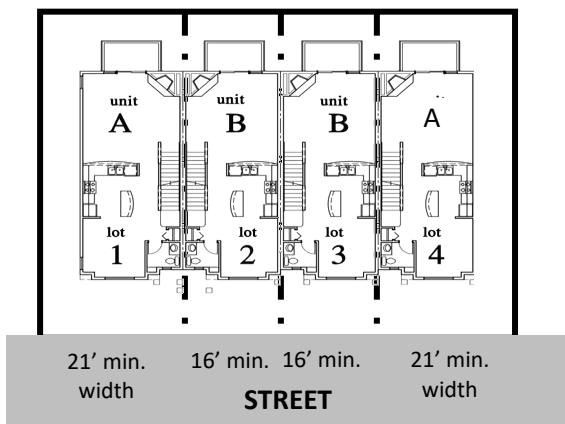

Four-lot attached house land division

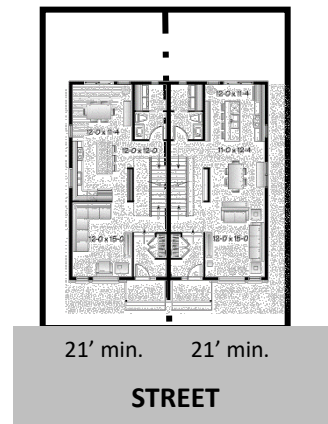

Two-lot "semi-detached" house land division

feet for attached houses allows a 50-foot wide lot to be divided and provides greater flexibility for lots that may be slightly narrower.

When there are three or more attached units in a row (only two are allowed in R5 through R20, but up eight may be attached in the R2.5 zone), lots for the middle units may be 16 feet wide. FAR and building coverage will be applied to the whole rowhouse site, as opposed to each individual lot. This is intended to provide consistent unit widths and sizes (as units on the end are required to have larger lots to accommodate 5-foot-wide exterior side setbacks). See the previous examples above.

Section 5: Map Amendments

This section addresses map changes proposed as part of the Residential Infill Project and is divided into the following subsections:

- A. Defining the Areas in the ‘z’ Overlay Zone:** Explains where and why the proposed Constrained Sites overlay zone (‘z’ overlay) will be applied to select areas;
- B. Rezoning Historically Narrow Lots:** Explains how and where the Comprehensive Plan Map and Zoning Map are proposed to be amended from R5 to R2.5 for some historically narrow lots; and
- C. Removing the Current ‘a’ Overlay Zone:** Explains the reasons and impacts for deleting portions of the current ‘a’ overlay, the Alternative Design Density overlay zone.

The previous section of this report (Section 4: Analysis of Amendments) provides the background and analysis of all the proposals. This section describes the methodology that was used to develop the map proposals.

A. Defining the Areas in the ‘z’ Overlay Zone

The purpose of an overlay zone is to apply distinct requirements or restrictions to specific geographic areas. Overlay regulations work in concert with the underlying base zone to further specific goals such as environmental or historic resource protection.

The *Revised Proposed Draft* allows additional housing options through base zone regulations in all R2.5, R5 and R7 zones. The proposed **Constrained Sites** overlay zone (‘z’ overlay) will limit areas within these zones that are less suitable for locating additional households. These areas either have natural hazards present (like floodplains or landslide hazards) or include inventoried natural resources. The overlay is intended to work in conjunction with the “Residential Infill Options” section of the R2.5 through R7 base zones to clearly define the lots that do not qualify for increased density based on these constraints.

The Planning and Sustainability Commission (PSC) discussed what constraints would be appropriate if the additional housing options were allowed in all R2.5, R5 and R7 zones. Staff received direction to look at the following constraints: FEMA 100-year floodplain, significant natural resources, landslide hazards, unpaved streets, sewer conveyance limitations and water system deficiencies. Coordinating with applicable service bureaus, staff reevaluated these constraints and developed the following approach to implement PSC’s direction.

Going from ‘a’ to ‘z’

*In this revised proposal, the previous application of an ‘a’ overlay that **allowed** additional housing types on roughly 66 percent of the R2.5 through R7 lots is replaced with the ‘z’ overlay, which **restricts** additional housing types on approximately 7 percent of the R2.5 through R7 lots. The remaining 93 percent of the lots in these base zones may utilize the additional housing types, subject to meeting other lot size and infrastructure requirements.*

Identifying constraints

- **Natural hazards and resource constraints**

Properties with the following natural hazards and/or natural resources should not be able to take advantage of new proposed base zone regulations that allow additional housing options.

- Flood risk (Map A1)
 - 100-year floodplain: areas that are within the FEMA 100-year floodplain including the FEMA-defined floodway
 - 1996 flood inundation area
- Landslide prone areas (Map A2). This map combines three types of landslide risk:
 - Deep landslide susceptibility: Deep landslides involve movement of a relatively thick layer of material.
 - Potentially rapid moving landslides: These areas are subject to debris flow hazards. Debris flows are mixtures of water, soil, rock and/or debris that have become a slurry and commonly move rapidly downslope.
 - Landslide scarps and deposits: These show areas where previous landslides have occurred and are indicative of areas more susceptible to future landslides.
- Significant natural resources: Areas ranked as having low, medium, or high value resources on the Natural Resource Inventory. (Map A3)

- **Infrastructure constraints**

The following infrastructure constraints are applicable to development of additional households, but due to their changing status, or ability to be rectified through utility improvements, they were not appropriate to map in the overlay. Assessment of specific infrastructure constraints will occur during the development application review.

- Sewer conveyance limitations: areas that may not be able to connect to a public sewer system due to topographic or other constraints. These constraints are codified in Title 17.
- Stormwater conveyance limitations: areas that may be unable to connect to an approvable off-site stormwater system or use on-site disposal methods. These are codified in Title 17 and the Stormwater Management Manual.
- Water system deficient areas: areas with substandard fire flow or water mains that are too small to accommodate sufficiently sized water meters. These constraints are codified in Title 21 and do not need further site limitations.
- Unpaved streets: These include public streets that lack a paved surface connection to another street. While street standards are also contained in Title 17, the Bureau of Transportation will allow a development to pay a Local Transportation Improvement Charge (LTIC) in lieu of constructing the street improvement. Additionally, a partial improvement in front of one parcel that does not connect to other paved streets does not accomplish the objectives envisioned by the residential Infill options. Private streets that do not connect to maintained public streets will also be ineligible for triplex and fourplexes.

- **Inapplicable constraints**

The following constraints that were used when identifying the *Proposed Draft 'a'* overlay are not factors in determining appropriate locations for the additional housing options.

- Physical barriers to centers and transit corridors: Staff's initial proposal limited additional housing types to within a quarter-mile distance from centers, corridors with frequent transit, and light rail stations. Areas where significant physical barriers that limited convenient connections to centers and transit corridors were also considered constrained, including areas with poor street connectivity, steep topography, natural features and other barriers such as freeways and railroads.

The PSC directed staff to remove proximity to transit and centers as a constraint, preferring to allow the additional housing types across a wider spectrum of the city.

- Johnson Creek Plan District: The PSC agreed that the FEMA 100-year floodplain area of the plan district should be considered "constrained," but not the entire district. The transfer of development rights from sites in this area will continue to be allowed to other residential sites in the district.
- Portland International Airport Noise Impact Zone: The PSC found that the few R7 through R2.5 zoned areas in the Airport Noise Impact Zone are in the lowest noise contour band (55 DNL) which requires that residents be given notice of airport noise but does not limit residential densities as is the case in higher decibel (68 DNL) contours.
- Glendoveer Plan District: The PSC found that the regulations of the Glendoveer Plan District maintain certain larger lot sizes and setbacks for R7 parcels, but not specific densities.

Proposal. Establish the 'z' Constrained Sites Overlay Zone

Based on the direction from the Planning and Sustainability Commission, the result of the overlay mapping is that nearly 93 percent of the lots in R2.5 through R7 zones could qualify for the additional housing types. Consequently, staff determined that it would be more appropriate to embed the additional housing type allowances in the base zone regulations (as opposed to in an overlay) and apply an overlay to the sites that are constrained instead. This is referred to as the 'z' overlay. Properties within the 'z' overlay will retain current allowances for duplexes on corner lots or a single accessory dwelling unit with a house.

Property owners can request to be removed from the constrained sites overlay through a discretionary map change request by demonstrating that the applicable constraints are not present or that the specific location of a mapped constraint (such as the floodplain) is incorrect. Sites may only be added to the overlay through a legislative project, which could occur as a result of new information (like flood elevations, new mandates, etc.).

The proposed 'z' overlay is shown on *Map A4: Proposed 'z' Overlay Zone (Constrained Sites Overlay)*. *Map A5: Proposed 'z' Overlay Zone with R2.5, R5 and R7 Zones* illustrates both the 'z' overlay and the R2.5, R5 and R7 parcels that are not mapped as constrained. The individual constraint layers that were used to map the proposed 'z' overlay are provided in Map A1: FEMA 100-Year Floodplain, Map A2: Landslide Risk, and Map A3: Significant Natural Resources.

Map A1: 100-year floodplain and floodway

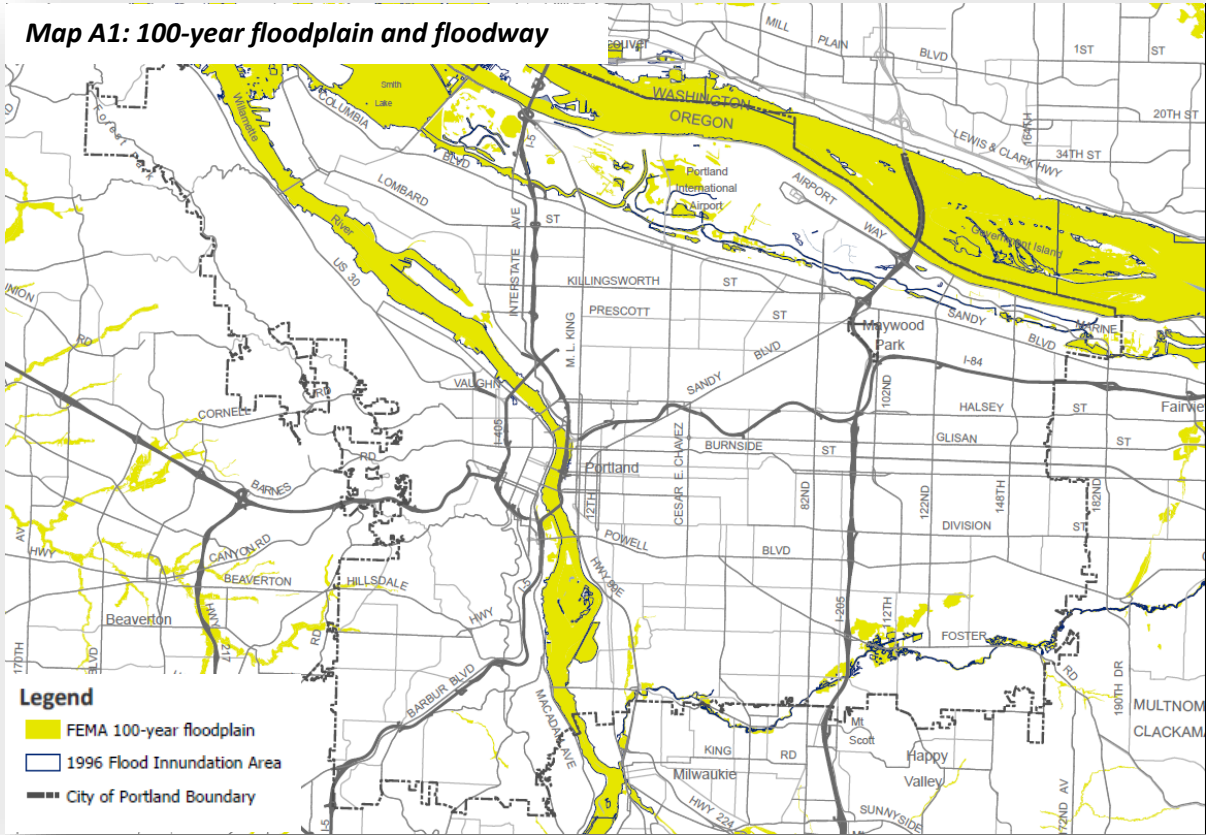

Map A2: Landslide Risk

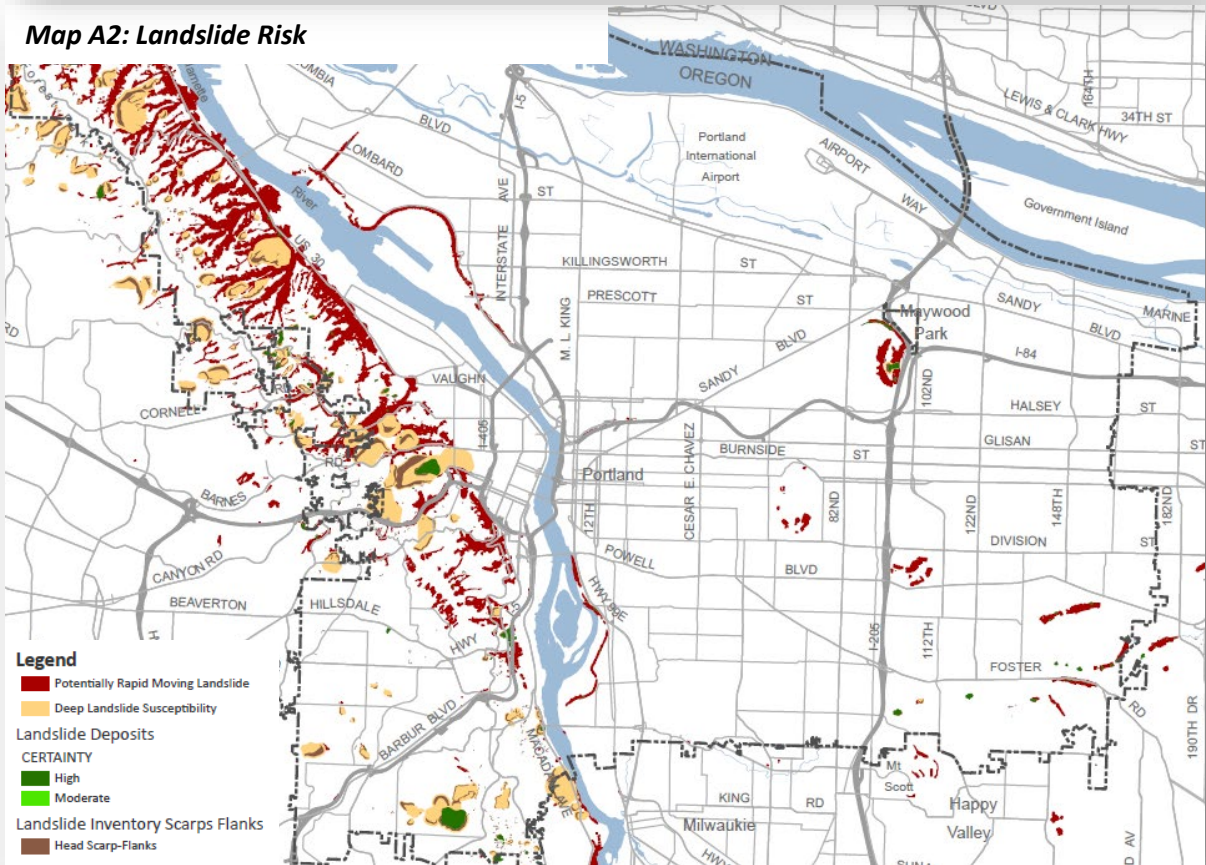

Map A3: Significant Natural Resources

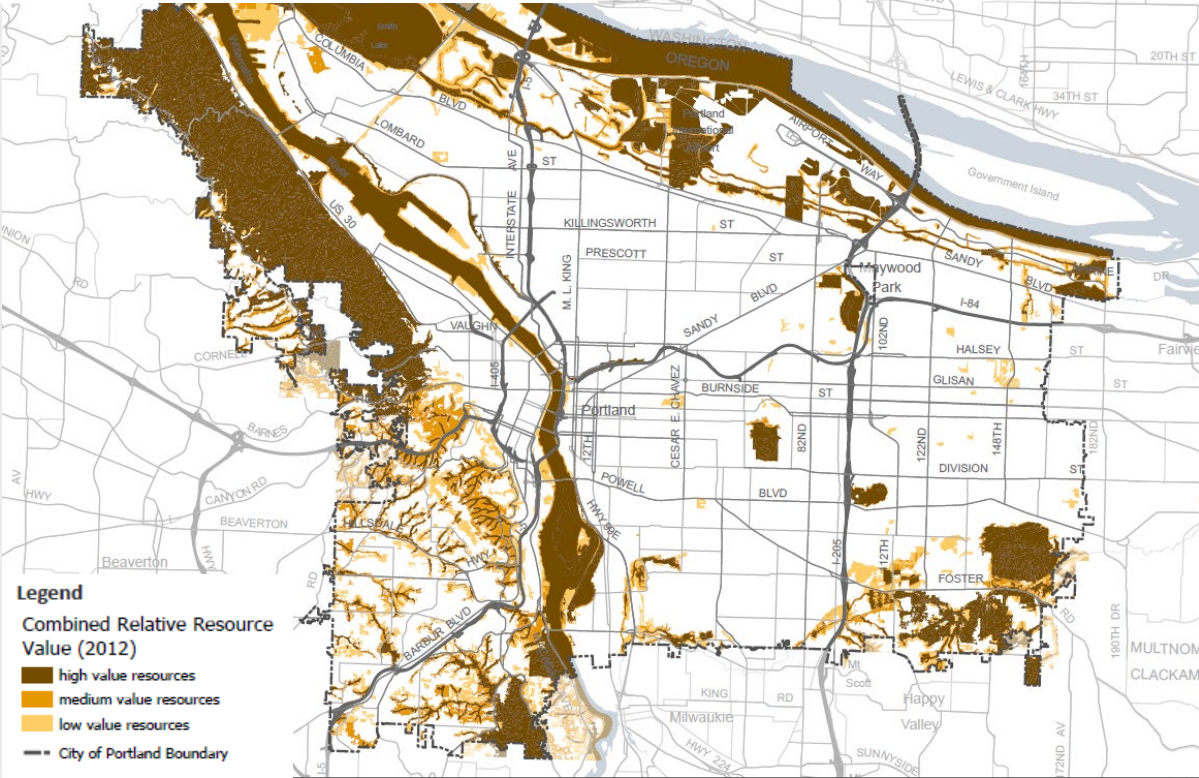

Map A4: Proposed 'z' Overlay Zone (Constrained Sites Overlay)

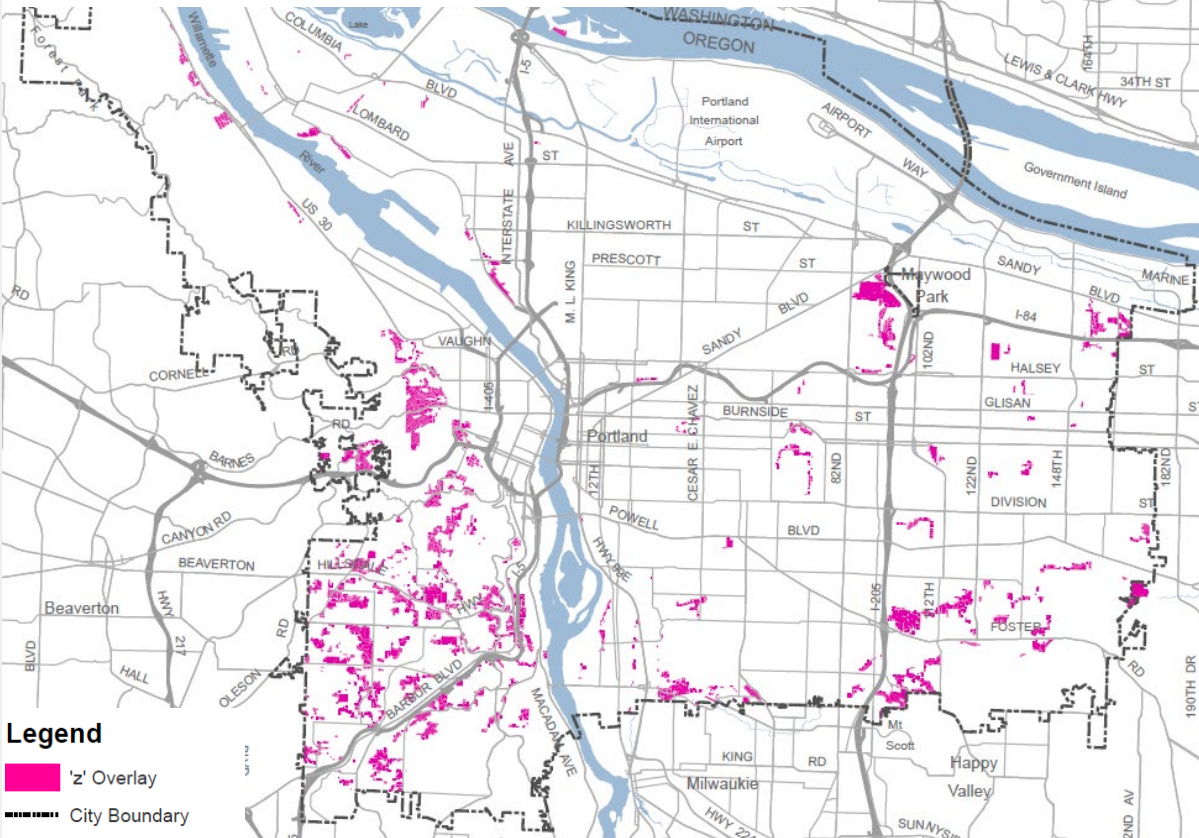

Map A5: Proposed 'z' Overlay Zone with R2.5, R5 and R7 Zones

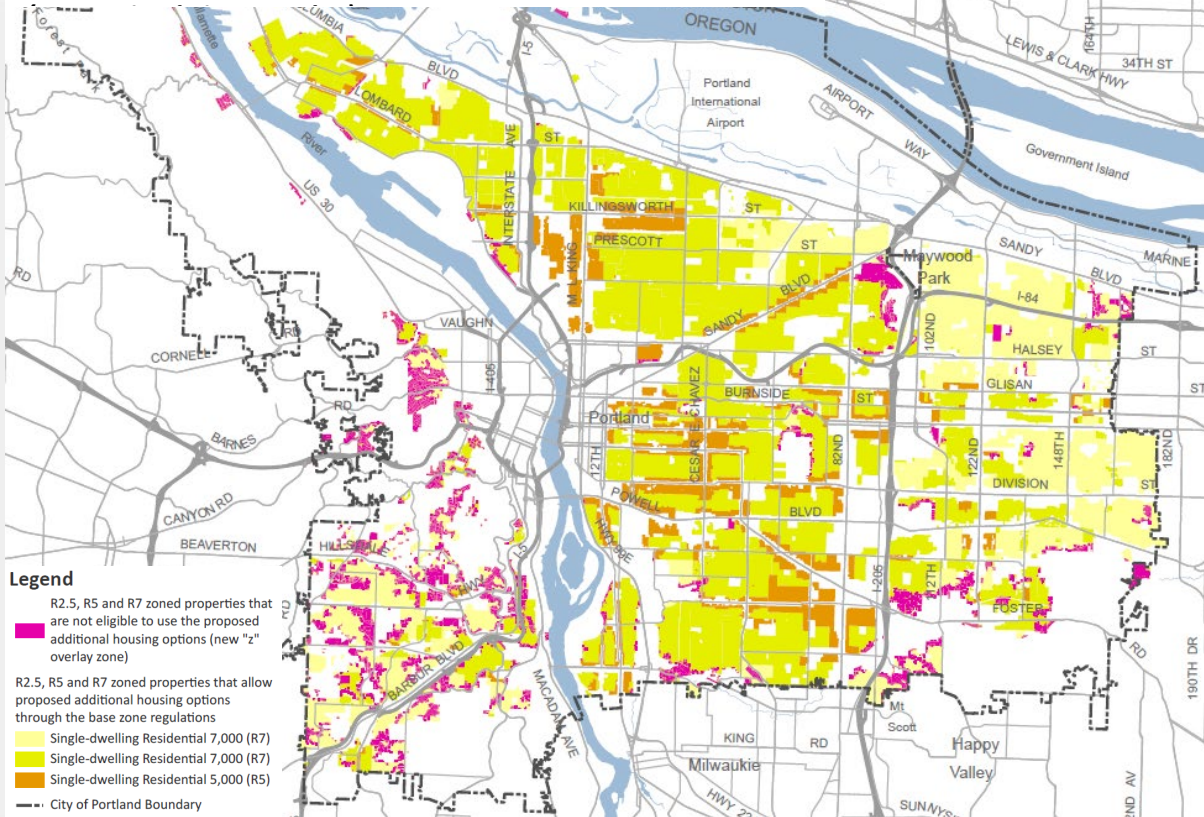

Summary of Areas Encumbered by 'z' Overlay Zone				
	Lots and Acreage in City		Lots and Acreage in proposed 'z' overlay	
	Lots	Acres	Lots	Acres
R7	32,839	7,501	5,674	1,712
R5	79,911	11,553	3,245	745
R2.5	19,804	2,392	156	29
TOTAL	132,554	21,446	9,075	2,486
Percentage of R2.5-R7	100%	100%	7%	12%
Percentage of SD zones	89%	69%	6%	8%
Percentage of city		30%		3%

B. Rezoning Historically Narrow Lots

Some areas with concentrations of historically narrow lots are proposed to be rezoned from R5 to R2.5 in order to ascribe a zoning designation that is consistent with the underlying established lot pattern. This change requires amendments to both the Zoning Map and the Comprehensive Plan Map. The following methodology was used to develop the proposed Comprehensive Plan and Zoning Map amendments for historically narrow lots.

Historically Narrow Lots

Historically narrow lots have underlying platting that creates lots that are smaller than typical for the current zoning. Most of these lots are in R5 zones and typically are 25 feet wide by 100 feet deep (2,500 square feet). The general development pattern consists of two or more combined historically narrow lots with a single house—reflective of a time when vacant land was more plentiful and less costly. This, in combination with subsequent R5 zoning and lot size standards, resulted in areas with R2.5 sized-lots but development patterns more consistent with 50-foot-wide lots. In 1985 the State of Oregon changed rules and required that cities recognize these substandard lots as discrete parcels. For more information on the background of historically narrow lots, refer to *Appendix G*.

There is an opportunity for these properties to be easily separated for two attached houses that can be sold “fee-simple” (i.e., house and land are sold together independent of the other attached unit, as opposed to rental units or condominium ownership units, where the land is owned in common). Alternatively, these lots can be “confirmed” as individual building lots and with a property line adjustment, the existing house can be retained while providing opportunities for a new fee-simple house to be built on the flag lot.

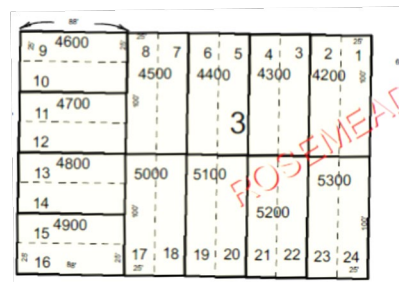

Tax map showing individual tax lots (e.g. 4600) comprised of two historically narrow platted lots (e.g. 9 & 10)

Staff reviewed plats citywide to identify areas with historically narrow lots. A higher concentration of these historically narrow lot plats exists in North and Northeast Portland, less in Southeast Portland and almost none in the east and west areas of the city.⁹ These concentrations of lots created the inventory of lots to further analyze. Single historically narrow lots or very small areas of historically narrow lots may not have been captured. See *Map B1: Historically Narrow Lots with Existing and Proposed R2.5 Zoning*.

Proximity to Centers, Corridors and Neighborhood Amenities

The proposed rezones build on the existing pattern of R2.5 zoning to create a transition from higher-density zoning (mixed-use and multi-dwelling) to surrounding single-dwelling zoning. Rezoning from R5 to R2.5 will also increase the allowable building size (Floor Area Ratio) from 0.5 FAR to 0.7 FAR, meaning these areas will provide a transition in scale from higher-intensity zones to lower-intensity zones. For these reasons, the proposed rezoning is limited to a two- to three-block proximity to:

- Gateway Regional Center, Town Centers and Neighborhood Centers

⁹ There are small pockets of historically narrow lots in the West Portland Park area and in Linnton. However, since 2003, these areas have had larger lot size requirements, based on infrastructure and natural hazard constraints.

- Frequent bus lines, MAX light rail stations and streetcar stops
- Neighborhood amenities such as parks, community centers and schools
- Smaller nodes of commercial zoning or neighborhood-serving retail uses

Physical Factors

In addition, the presence of the following factors weighed *favorably* towards rezoning:

- **Alley access.** Alley access provides greater flexibility and better design of houses on narrow lots.
- **Consistent zoning pattern.** Where adjacent areas were zoned R2.5 or a higher-intensity zoning designation, the R2.5 zone provides for a logical transition to lower-intensity zones.
- **Existing development patterns.** Areas where historically narrow lots have already been developed with narrow houses were weighed favorably.

The following factors weighed *unfavorably* towards rezoning:

- **Discontinuous and unclear zoning patterns.** Creating inconsistent zoning patterns (for example, R2.5 leapfrogging across other zones or creating islands of isolated R2.5 zones) was avoided.
- **Public land.** Publicly-owned properties that are in public use were avoided.
- **Site constraints.** Areas with a high number of unimproved streets, poor connectivity or stormwater or topography issues were avoided.

Equity Lens

These proposed zone changes will allow development of more historically narrow lots with fee-simple housing options. Where development occurs, this could potentially displace existing renters but also benefits current and future homeowners in these areas, especially given that homes developed on narrow lots are likely to be smaller and therefore less expensive than homes developed on larger lots. An equity lens was applied to the rezoning proposal, but the results did not affect the outcome because historically under-served and under-represented groups were not found to be disproportionately impacted.

Consideration of demographic factors. Staff examined the proportion of communities of color in census block groups that coincided with areas where rezones are proposed. The table below shows that the rezoned areas do not disproportionately affect any racial or ethnic group compared to the citywide average.

Comparison of Citywide Race/Ethnicity Composition to Proposed Rezone Areas								
	White	Black/African American	American Indian/Alaskan Native	Asian-American	Pacific Islander	Other race	Two or more races	Latino/Hispanic
Citywide	71.80%	5.52%	0.49%	7.42%	0.62%	0.28%	4.34%	9.54%
Rezones	74.65%	4.91%	0.64%	6.97%	0.91%	0.31%	4.00%	7.61%

Consideration of geography. The platting pattern and the concentration of historically narrow lots in certain areas of the city predate modern zoning, and their location is an artifact of history. Staff therefore examined whether the rezone proposals affected one part of the city more than another. This is not to say that there is equal distribution of these lots by neighborhood.

The table below shows the geographic distribution of R5 zoned historically narrow lots citywide and how many are proposed to be rezoned. Unsurprisingly, East and West areas have the fewest historically narrow lots, while North has the most, which corresponds to the concentration of historically narrow lots in these areas.

Allocation of Narrow Lots and Proposed Rezones			
	Total narrow lots	Narrow lots proposed to be rezoned	Percent of narrow lots proposed to be rezoned
North	5,878	2,138	36%
Northeast	4,567	2,220	49%
Southeast	3,281	1,984	60%
West	447	27	6%
East	262	170	65%
Total	14,435	6,539	45%

The table shows that out of 14,435 historically narrow lots in the city, about 45 percent—6,539 lots—are proposed to be rezoned.

It also shows that the rezones are proposed for about one-half to two-thirds of the narrow lots in all parts of the city, except for the West pattern area. This is also not surprising, as most of the historically narrow lots in West are in West Portland Park, an area with steep slopes, unpaved streets and considerable infrastructure constraints.

Proposal: Rezone half the historically narrow lots from R5 to R2.5

The proposal amends the Comprehensive Plan and rezones almost half—6,539 out of 14,435—of the historically narrow lots in the city from R5 to R2.5. The rezones are proposed in areas with the most convenient access to services and where physical barriers and site constraints are not present. The proposal does not disproportionately affect one racial or ethnic group more than another. Finally, about one-half to two-thirds of the historically narrow lots are proposed to be rezoned to R2.5 in each quadrant of the city, except West, largely due to existing restrictions in West Portland Park, and North, where many narrow lots were farther from transit and commercial services.

While the proposed additional housing types in the base zone would allow a duplex, triplex or fourplex on combinations of two or more of these narrow lots (because one narrow lot would not meet minimum lot size requirements), rezoning them provides for more floor area, which provides for larger family-sized units (1,750 square feet each versus 1,250 square feet allowed in R5).

The proposed rezones are shown on *Map B2: Proposed Comprehensive Plan Map and Zoning Map Changes (R5 to R2.5)*. *Map B1: Historically Narrow Lots with Existing and Proposed R2.5 Zoning* provides the context for the proposed rezones with other current R2.5 zoning along with the distribution of historically narrow lot plats throughout the city.

Map B1: Historically Narrow Lots with Existing and Proposed R2.5 Zoning

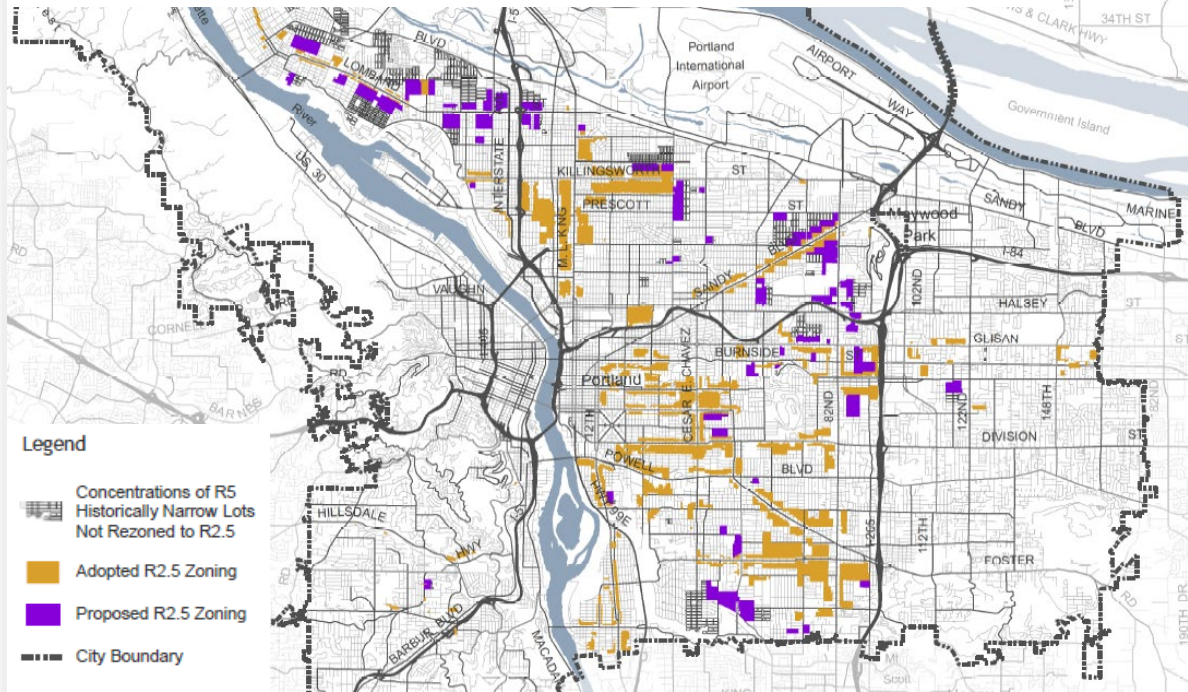

Map B2: Proposed Comprehensive Plan Map and Zoning Map Changes (R5 to R2.5)

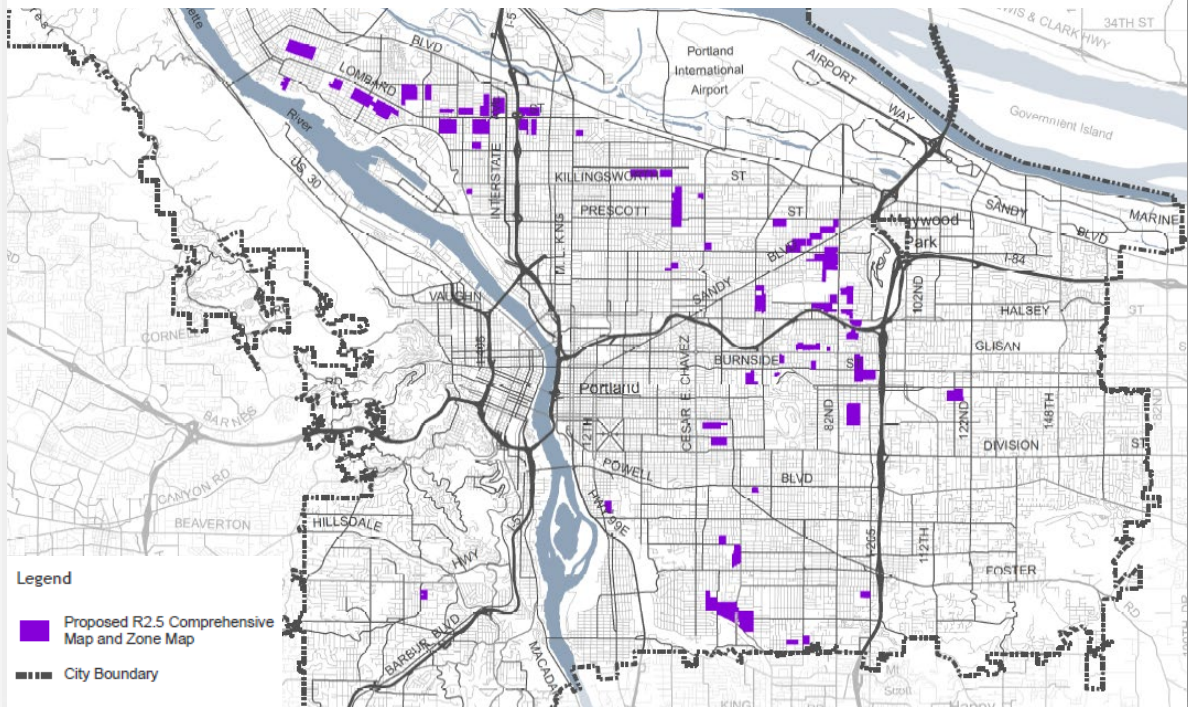

C. Removing the Current ‘a’ Overlay Zone

The ‘a’ Alternative Design Density overlay zone was adopted with the Albina Community Plan in 1993 as a way to allow additional housing options that met certain design requirements. It was applied to R1, R2 and R3 (multi-dwelling zones) and R2.5, R5, R7 and R10 (single-dwelling zones). The ‘a’ overlay first applied in the Albina community (North/Northeast Portland) and was later expanded to areas in Lents, Powellhurst-Gilbert and Sellwood.

In single-dwelling zones, the original ‘a’ overlay offered an additional dwelling unit in the form of an internal ADU, attached houses on vacant lots, and triplexes on 4,800-square-foot lots in the R2.5 zone. Design review, with the option of using Community Design Standards, was required for these additional units.

In more recent years, many of the original ‘a’ overlay provisions have been incorporated into the base zone regulations. The regulations that remain in the ‘a’ overlay have not been well-utilized. In fact, of the nearly 45,000 properties in the overlay zone, staff estimates that fewer than 250 properties have used the ‘a’ overlay provisions.¹⁰ This was in large part due to the requirements for Design review and later due to the incorporation of similar allowances in the base zones, where Design review was not required.

Proposal: Remove the ‘a’ overlay zone from single dwelling zones

The proposal removes the ‘a’ overlay for all single-dwelling zones sites as shown on *Map C1: Alternative Design Density Overlay Zone to be Removed (RF-R2.5 Zones)*. Concurrently, the Zoning Code is being amended to delete the associated single-dwelling ‘a’ overlay zone provisions (see Section 6: Zoning Code Amendments in *Volume 2*).

Removing the ‘a’ will have little impact in the single-dwelling zones. The new base zone’s additional housing types will be allowed on these lots, provided the lot is of adequate size and does not have the new ‘z’ overlay applied. There are 25 lots with R2.5a zoning that are large enough for a triplex today that with the application of the ‘z’ will be restricted from building three or four units.

The Better Housing by Design project, which is addressing the regulations in multi-dwelling zones, is proposing to remove the remaining ‘a’ Alternative Design Density overlay zone from those zones, as the provisions are incorporated or superseded by changes in the base zone.

¹⁰ Staff analyzed building permit records for properties in the current ‘a’ and flagged those that either went through a design review or used the Community Design Standards (prerequisites for use of the ‘a’). Of the 45,420 properties, there were 5,889 permits for new construction or exterior alterations between 1995 and 2016. Of those, 68 properties applied for design review, and 144 properties used Community Design Standards. In addition, according to the 2003 Accessory Dwelling Unit Monitoring Project Inventory, there were 13 ADUs created in the ‘a’ before they were allowed more broadly.

Map C1: Alternative Design Density Overlay Zone to Be Removed (RF-R2.5 zones)

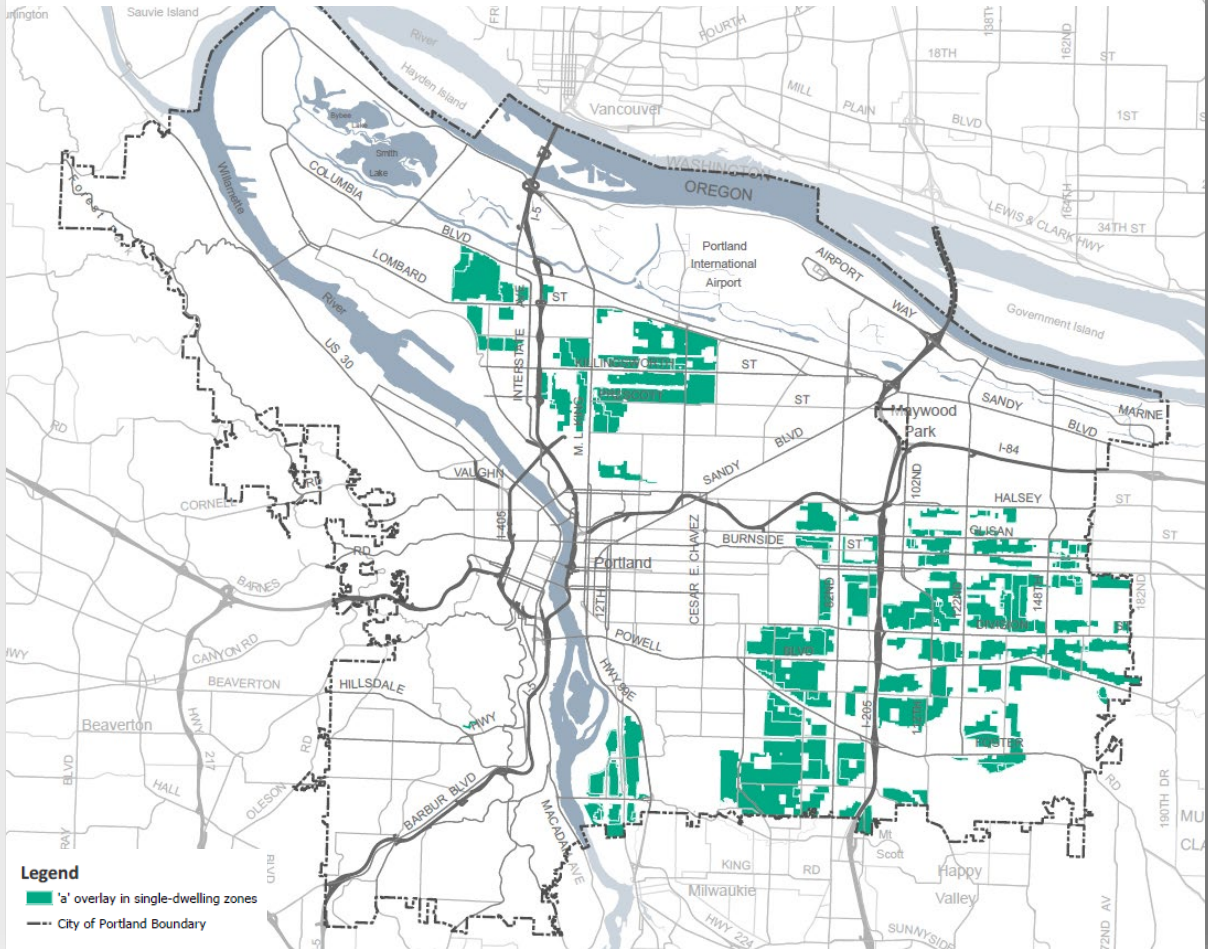

The Residential Infill Project is updating Portland’s single dwelling zoning rules to meet the changing needs of current and future residents.

For more information:

Visit the project website www.portlandoregon.gov/bps/infill

Email the project team Residential.Infill@portlandoregon.gov



What is the “Revised Proposed Draft”?

The Portland Planning and Sustainability Commission (PSC) held public hearings on May 8 and 15, 2018. Over 130 people testified in person, and more than 1,200 written comments were received. The PSC, through several work sessions, revised staff’s proposal in response to the testimony. This necessitated a new draft Code and Commentary in order to ensure that the changes did not create inconsistencies with other regulations. The PSC will review this ***Revised Proposed Draft*** and may decide to further amend the proposal before finalizing their recommendation to Portland City Council. The public will have an opportunity to provide formal testimony to City Council on the ***Recommended Draft***.