

# 1732 NE 2ND AVE

DESIGN REVIEW PRESENTATION

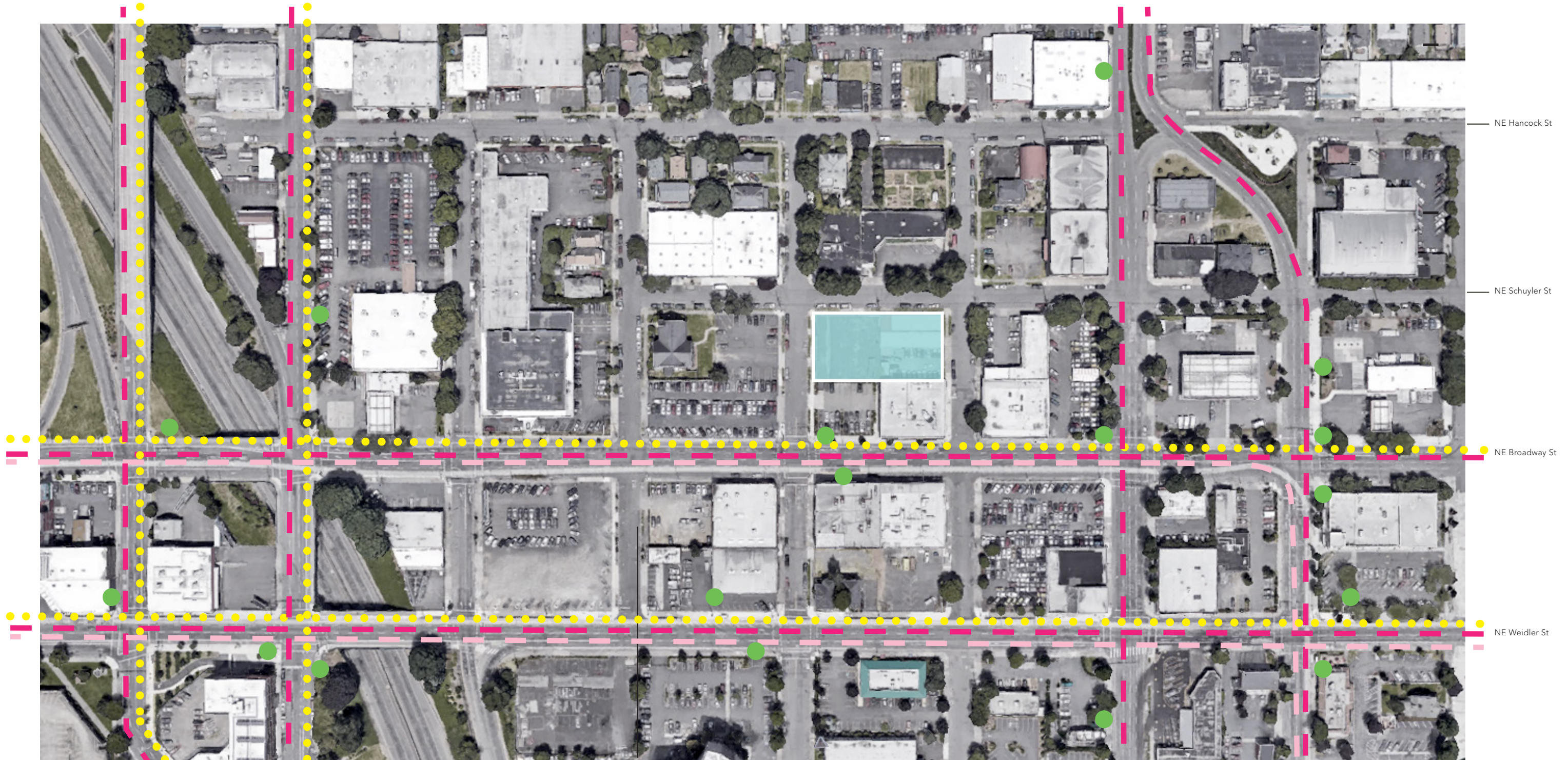

# SITE AND CONTEXT



- Site
- Bike Transit
- Bus Transit
- Streetcar
- Transit Stop

N Vancouver Ave
N Williams Ave
I-5 Freeway
NE Victoria
NE 1st Ave
NE 2nd Ave
NE 3rd Ave
NE MLK Blvd
NE Grand Ave



# URBAN CONTEXT

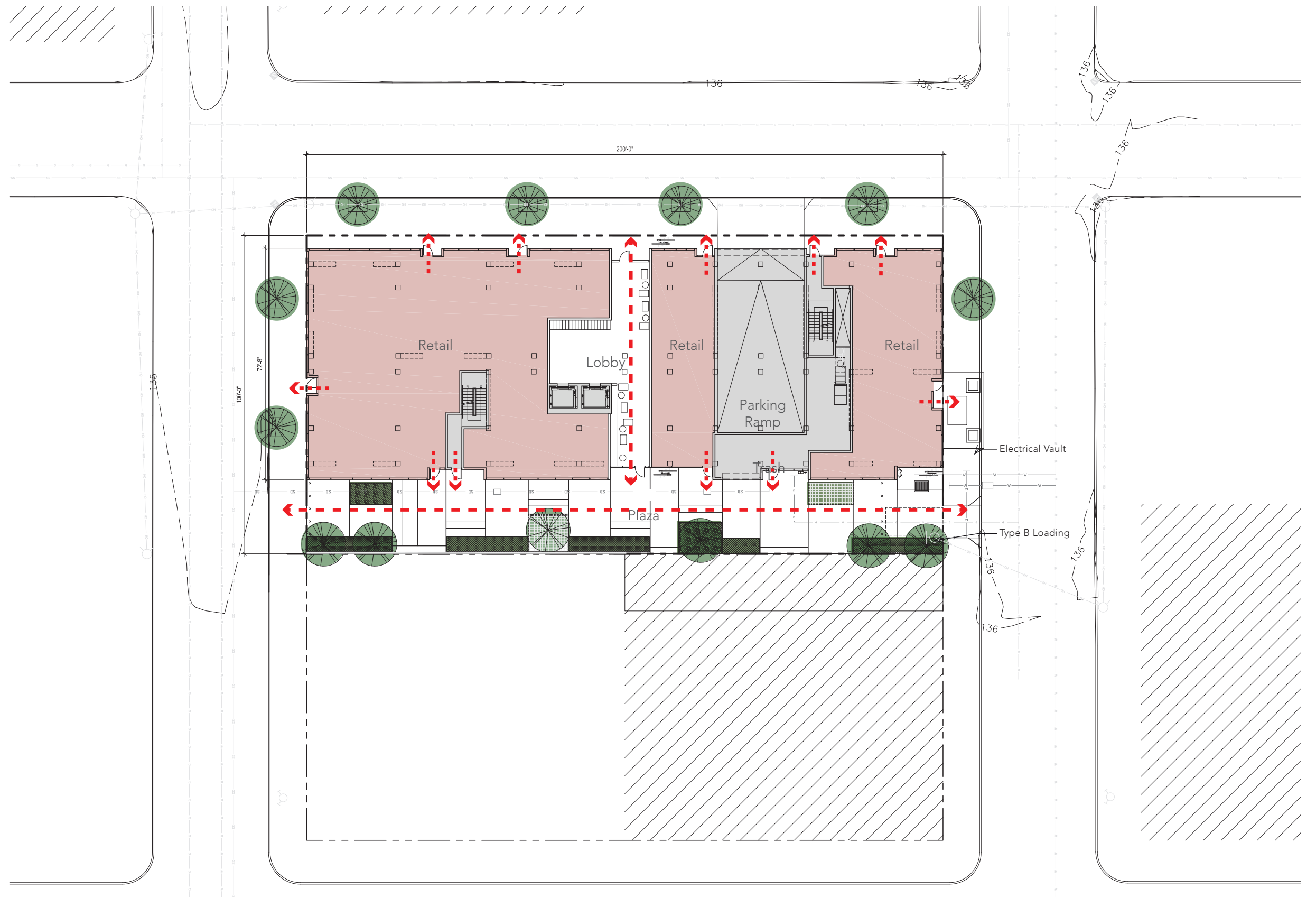

# PROPOSED SITE PLAN

# MASSING, URBAN GESTURE AND MODULAR DESIGN CONCEPTS



## MODULAR EXAMPLES

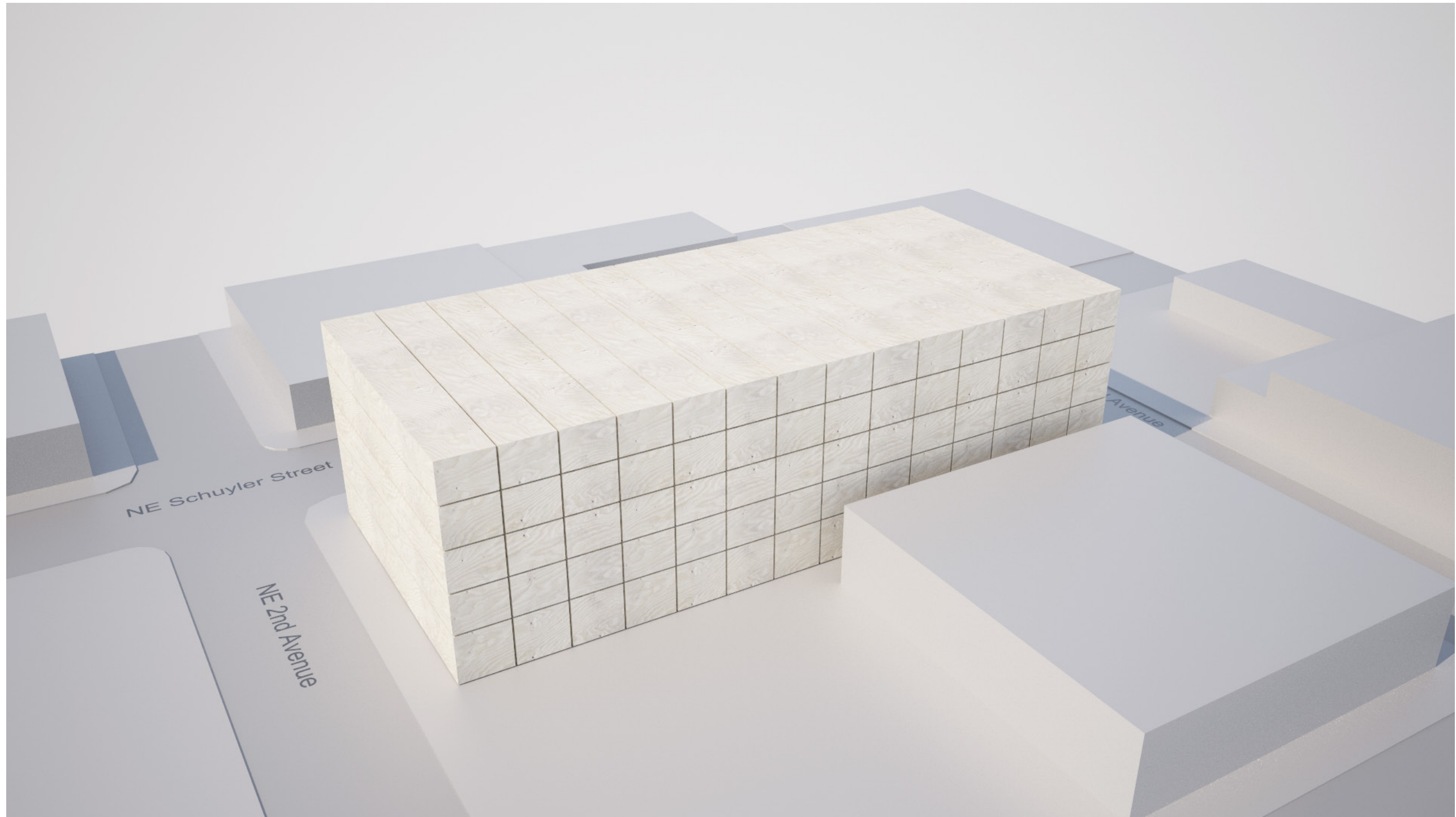

# MASSING DIAGRAM

SITE

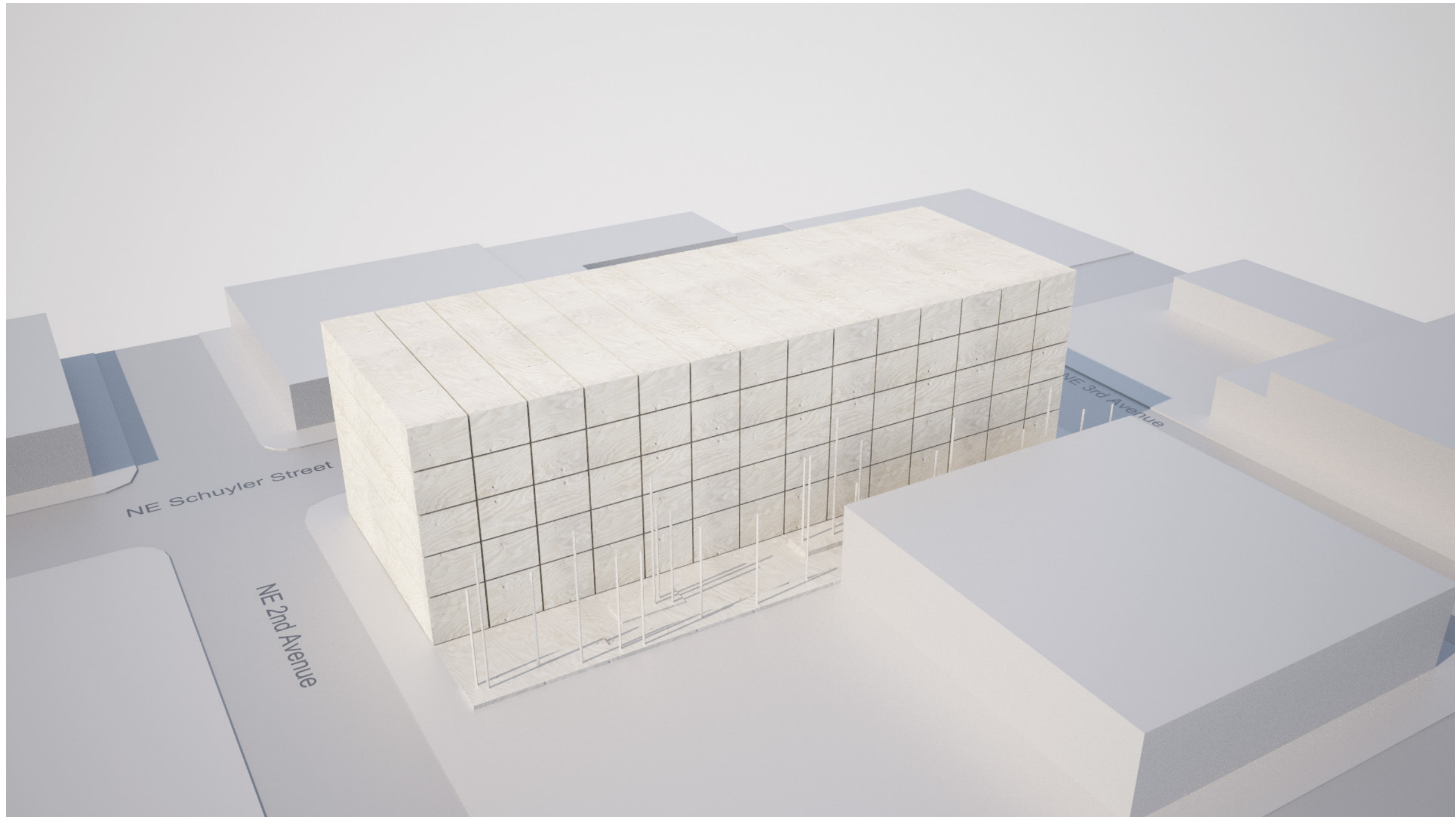

# MASSING DIAGRAM

SHIFT



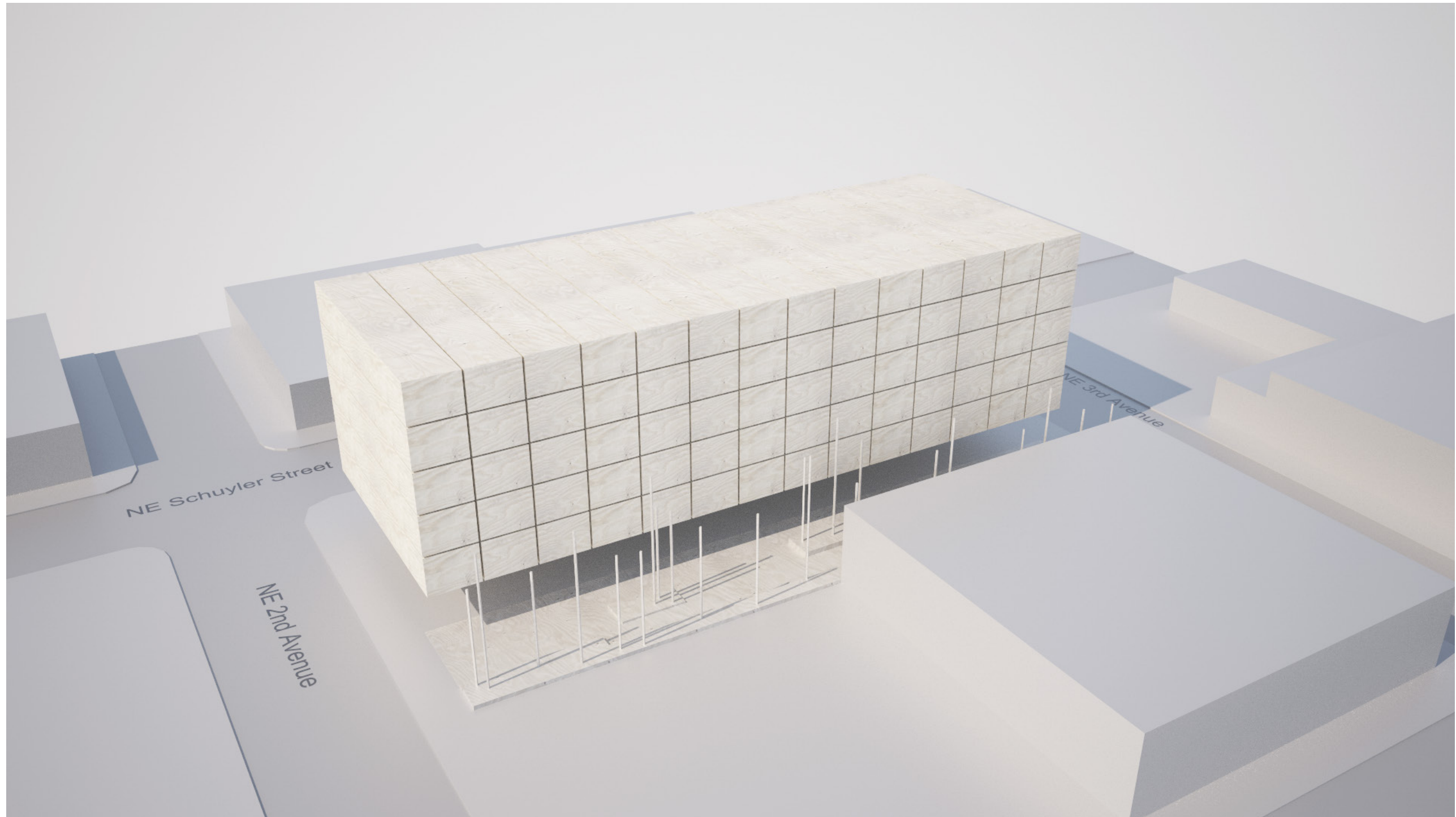

# MASSING DIAGRAM

LIFT

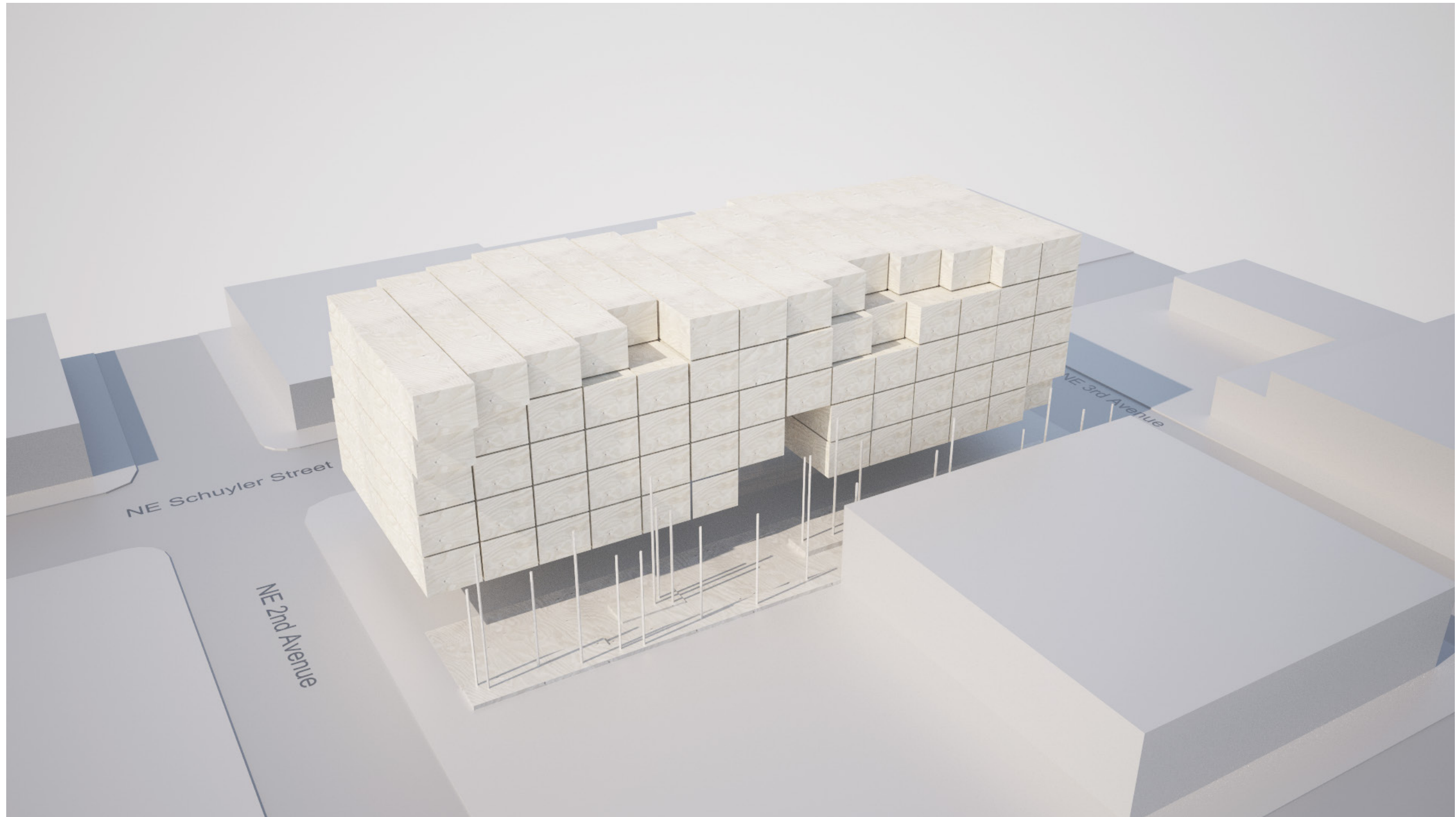

# MASSING DIAGRAM

PUSH / PULL

## 6 STORY DESIGN CONSIDERATIONS

1. Maintain district character in transition
2. Further articulation toward organic massing
3. Modify structure to enhance open ground floor active use
4. Further information regarding stucco and gasketing
5. Increased canopy coverage



# SIDE BY SIDE

NORTH ELEVATION



# SIDE BY SIDE

SOUTH ELEVATION



# PROPOSED BUILDING

NORTH ELEVATION



# PROPOSED BUILDING

SOUTH ELEVATION



# PROPOSED BUILDING

GROUND LEVEL STOREFRONT





NE 3RD AND SCHUYLER ST



SOUTHWEST CORNER



GROUND LEVEL STOREFRONT



NORTH ELEVATION



VIEW FROM BROADWAY

## 9 STORY DESIGN CONSIDERATIONS

1. Maintain district character in transition
2. Further articulation toward organic massing
3. Modify structure to enhance open ground floor active use
4. Further information regarding stucco and gasketing
5. Increased canopy coverage



# SIDE BY SIDE

NORTH ELEVATION



# SIDE BY SIDE

SOUTH ELEVATION





# PROPOSED 9 STORY BUILDING

NORTH ELEVATION



## PROPOSED 9 STORY BUILDING

VIEW FROM BROADWAY



# PROPOSED 9 STORY BUILDING

NE 3RD AND SCHUYLER ST



# PROPOSED 9 STORY BUILDING

SOUTHWEST CORNER

# DETAILS

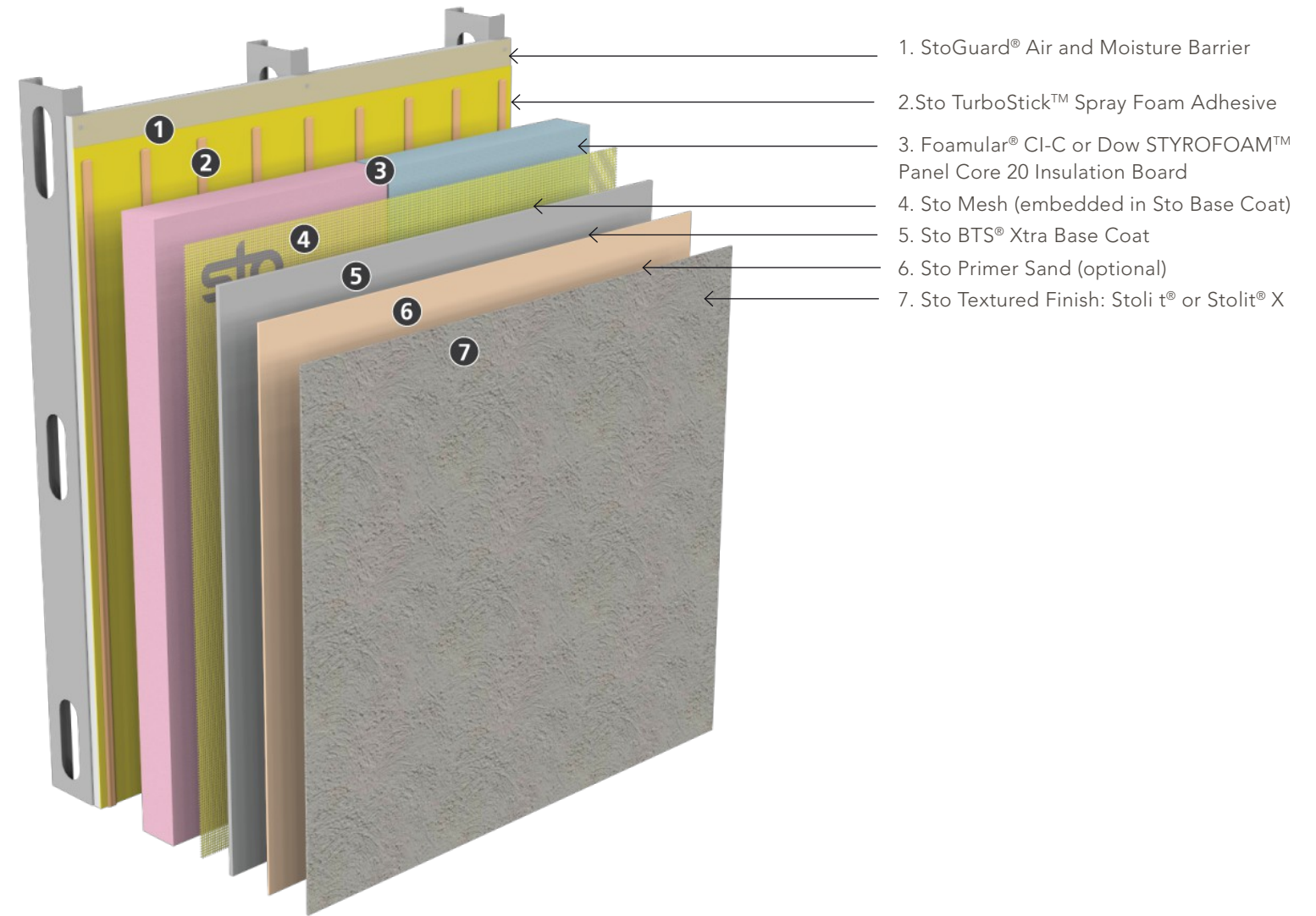
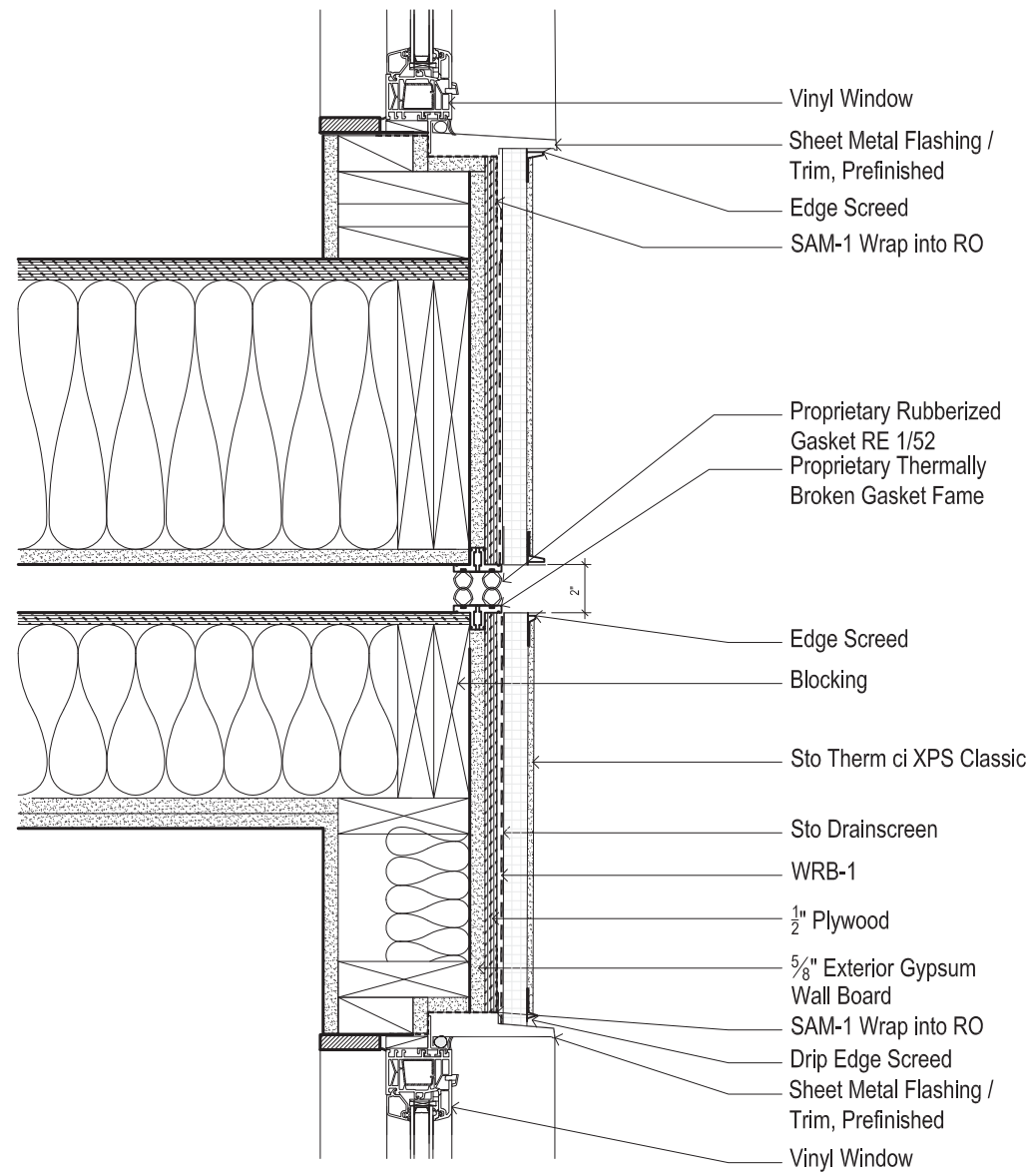

# MATERIALS

## STUCCO DETAILS

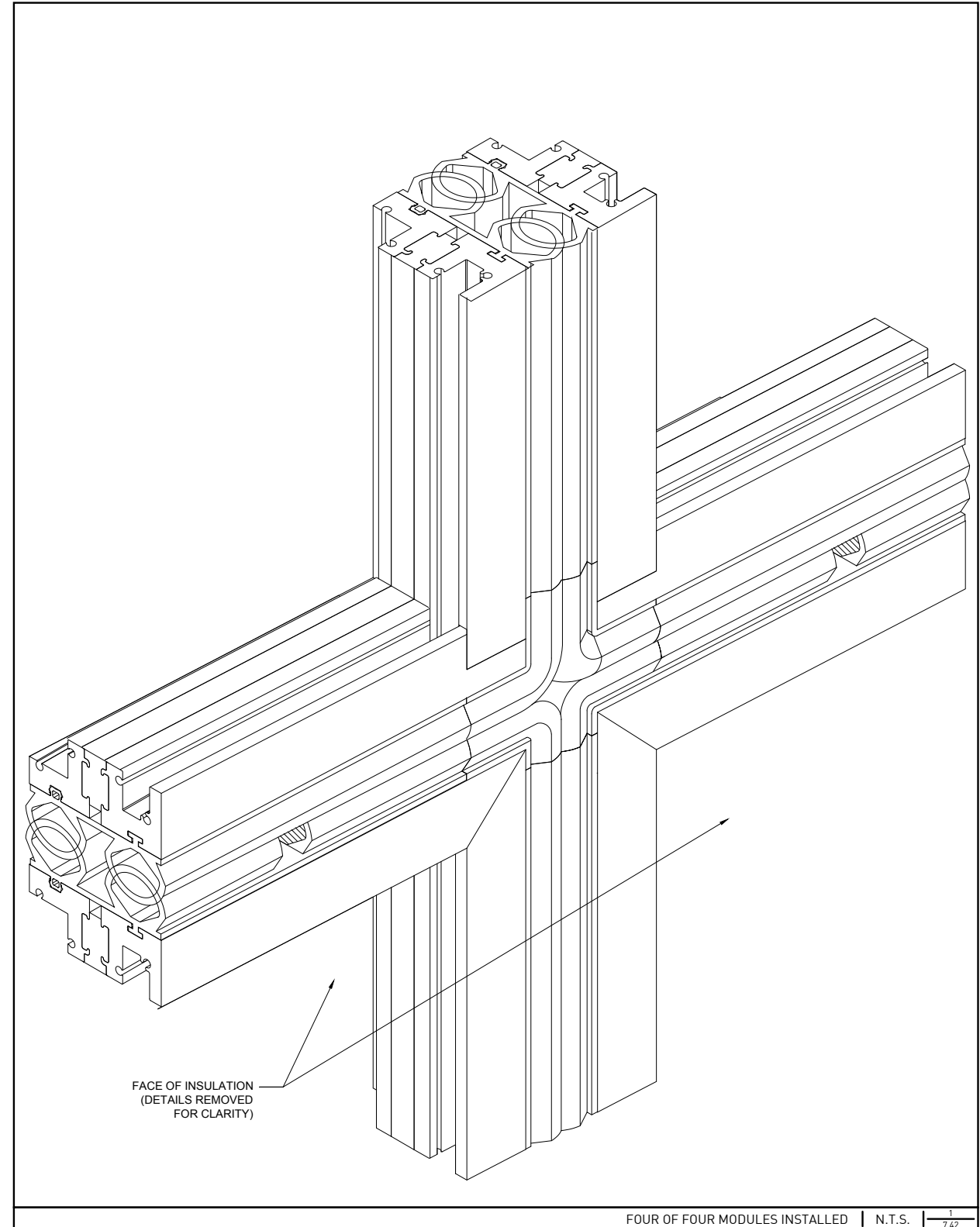
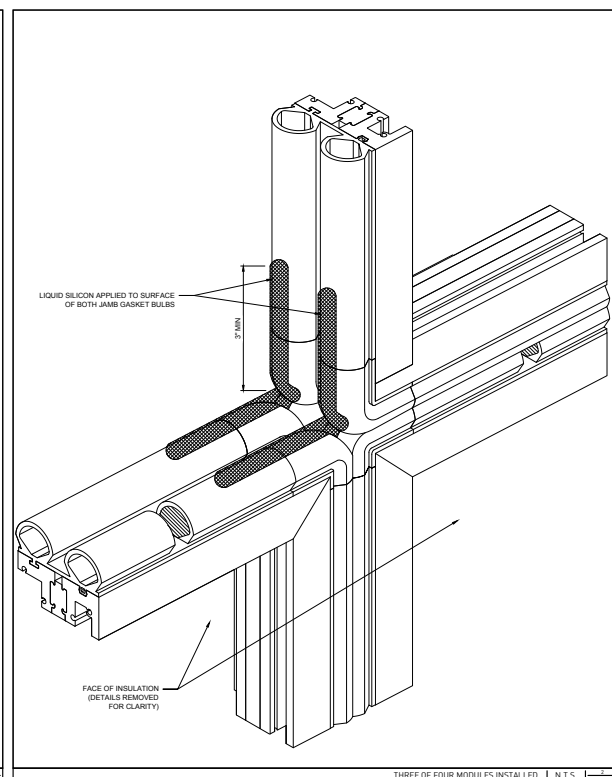
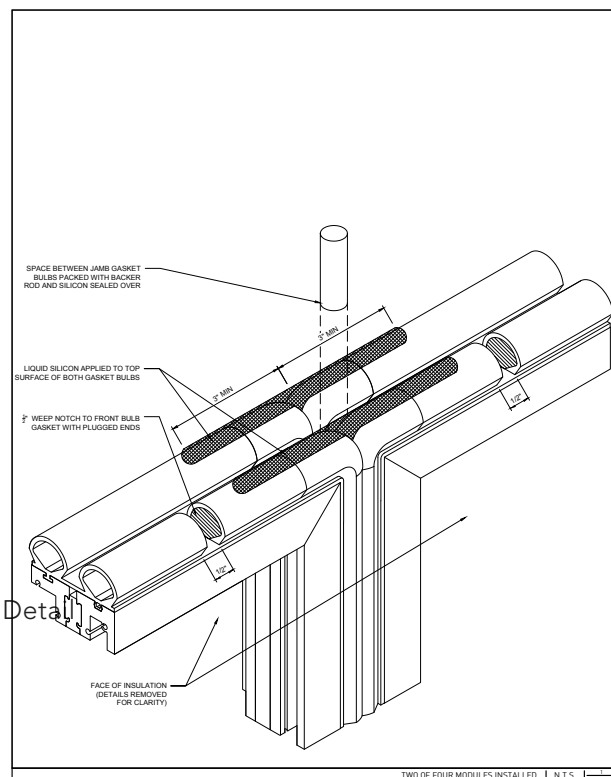
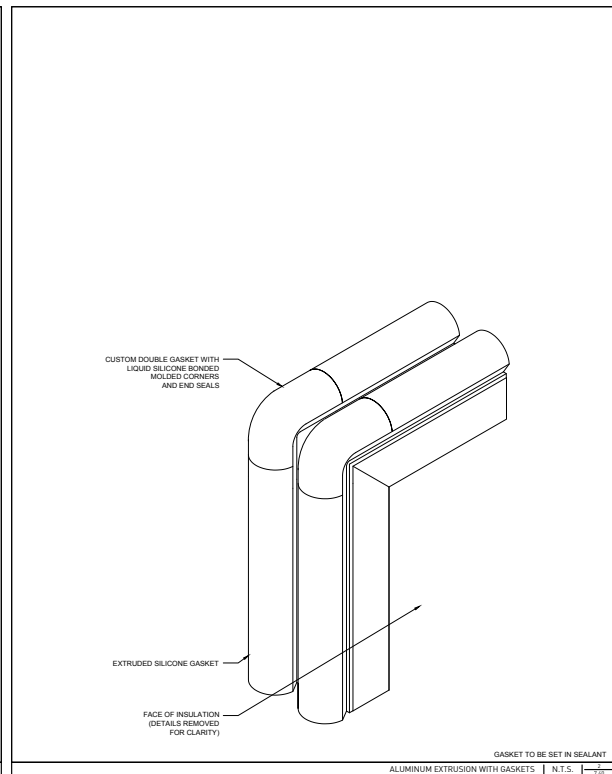
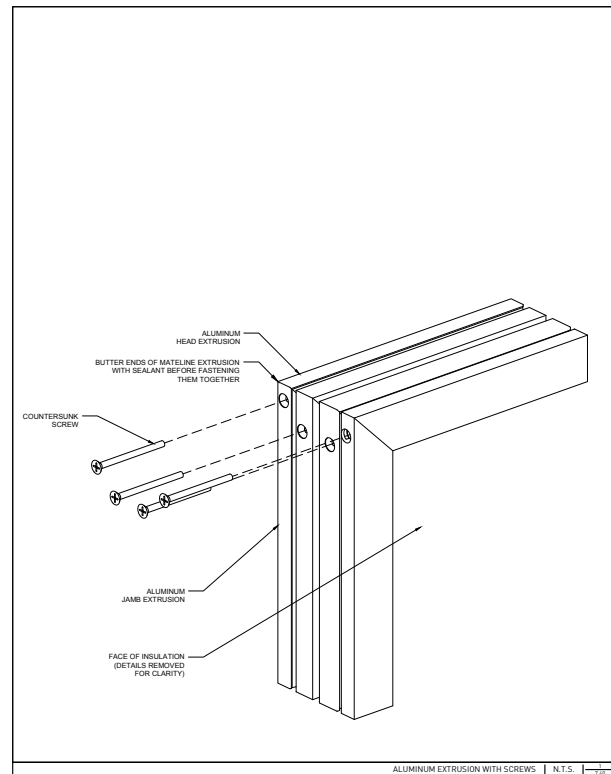

1. Gasket Detail

# MATERIALS

## GASKET DETAILS







VIEW FROM COURTYARD

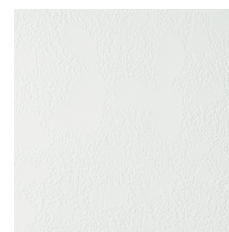

1. STUCCO



2. GLASS

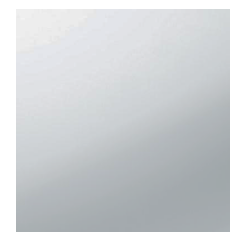

3. SPANDREL GLASS



4. ACM METAL PANEL

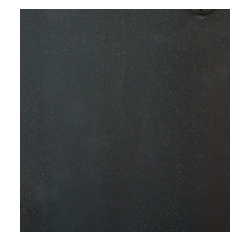

5. STEEL SIDINGS

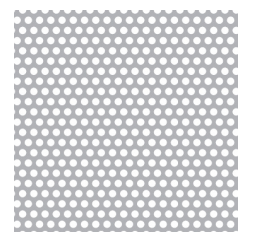

6. METAL SCREEN

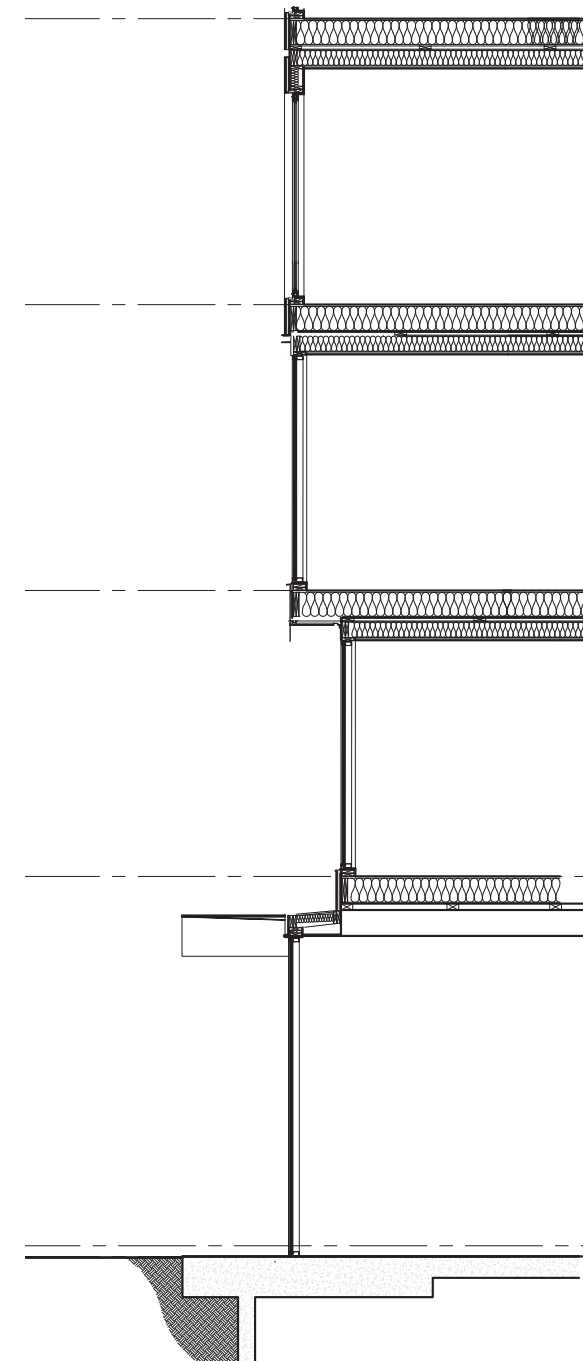

TYPICAL CANOPY VIEW

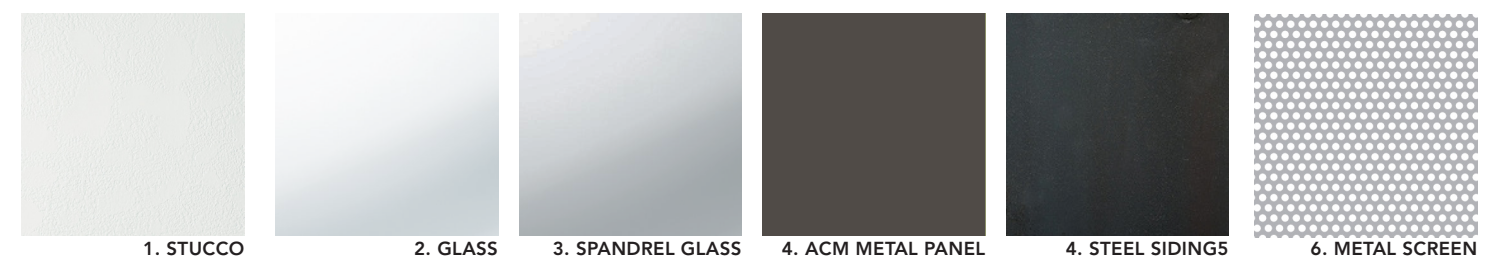

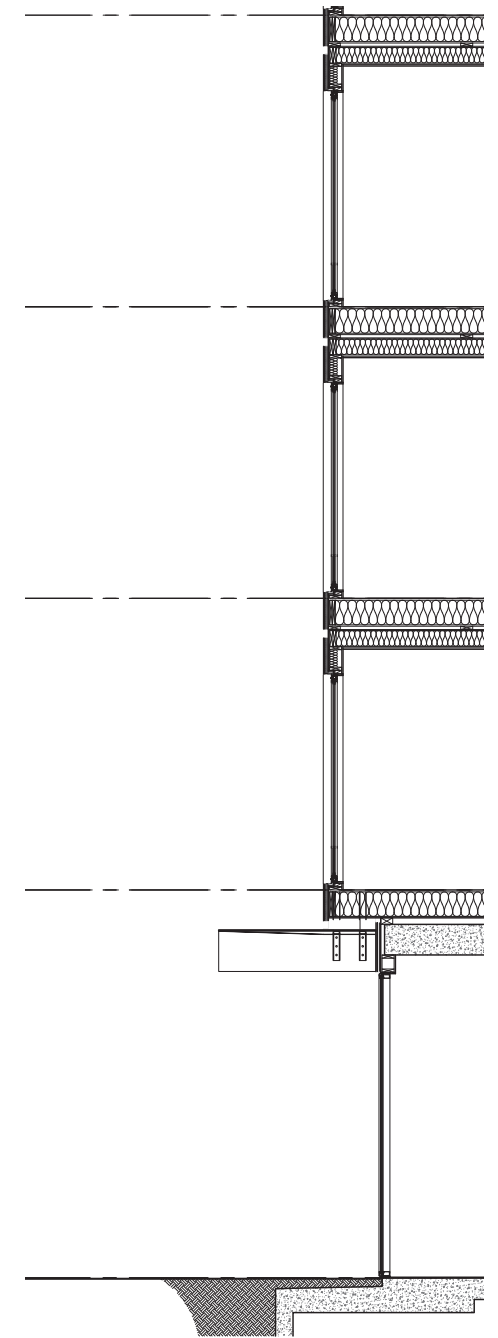

TYPICAL CANOPY VIEW

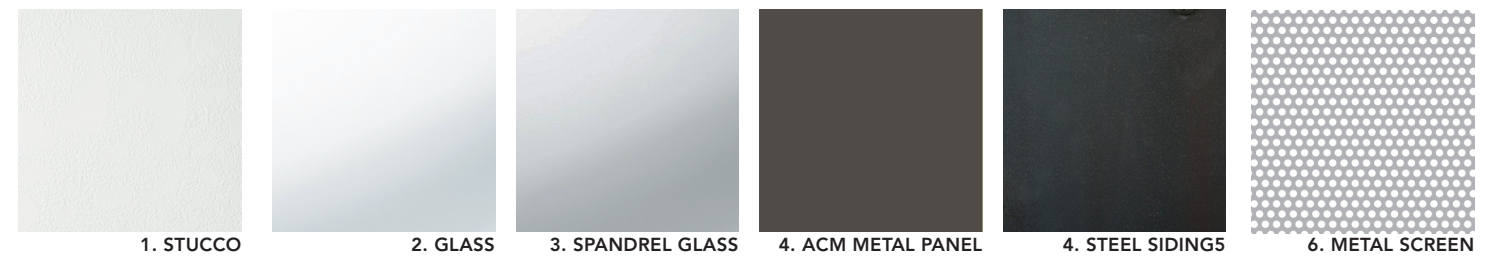

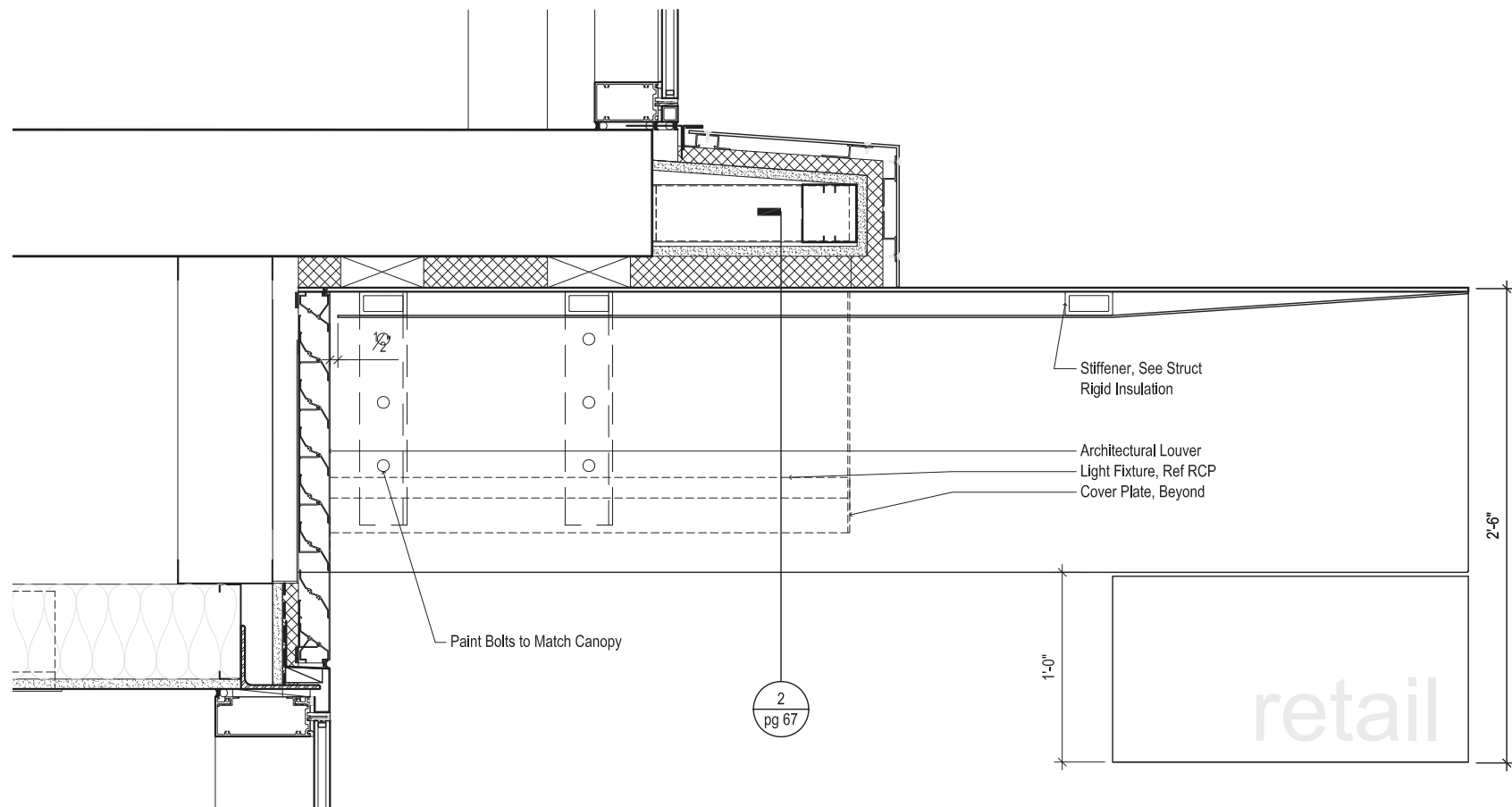

1. Canopy Section with Light

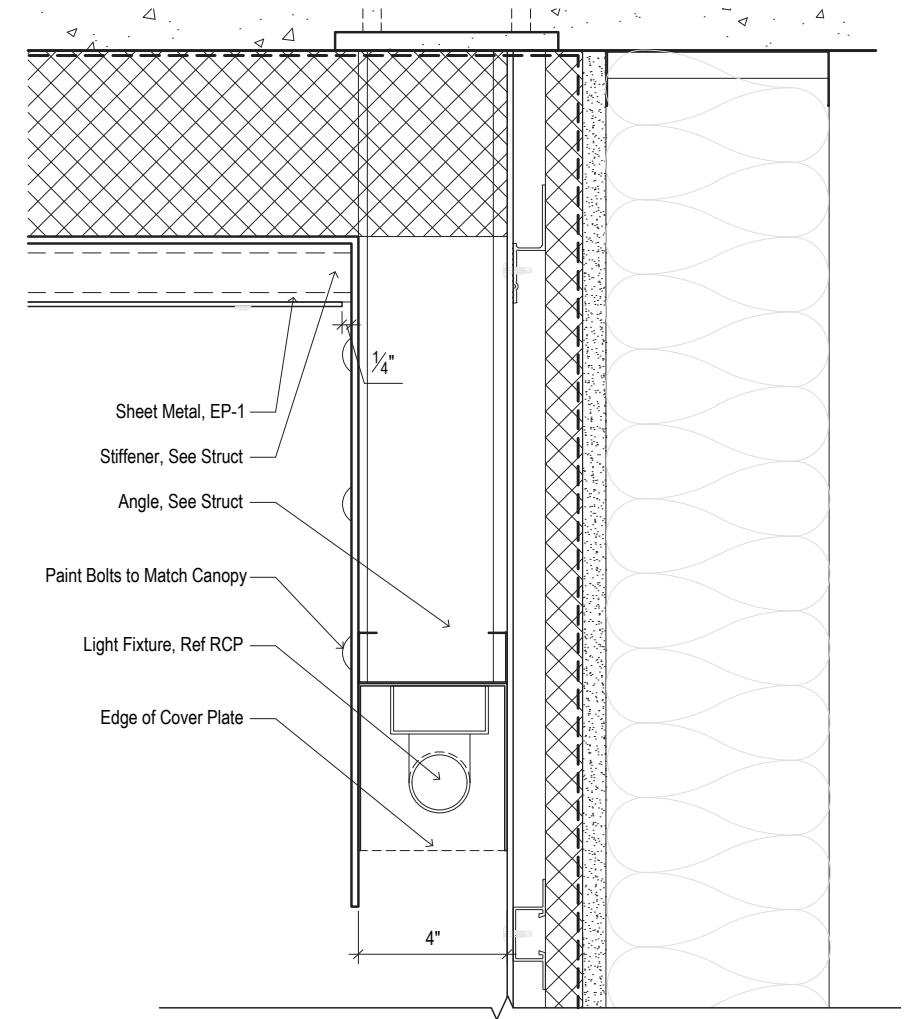

2. Canopy Light Detail

CANOPY LIGHTING DETAILS

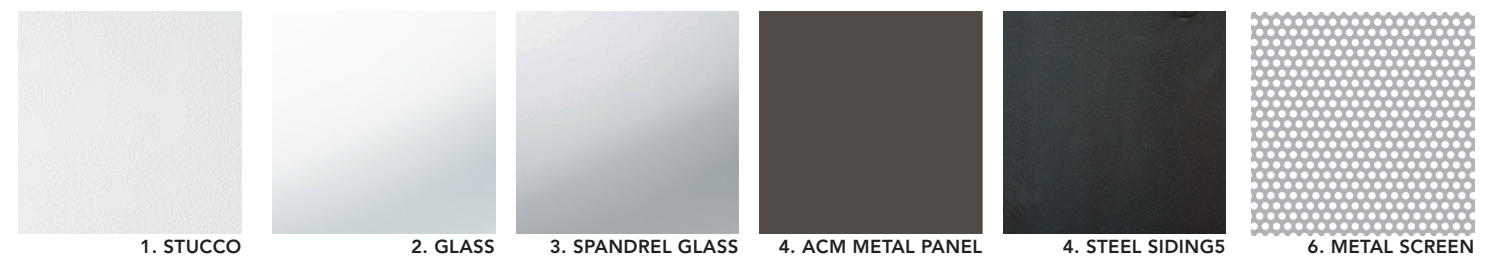

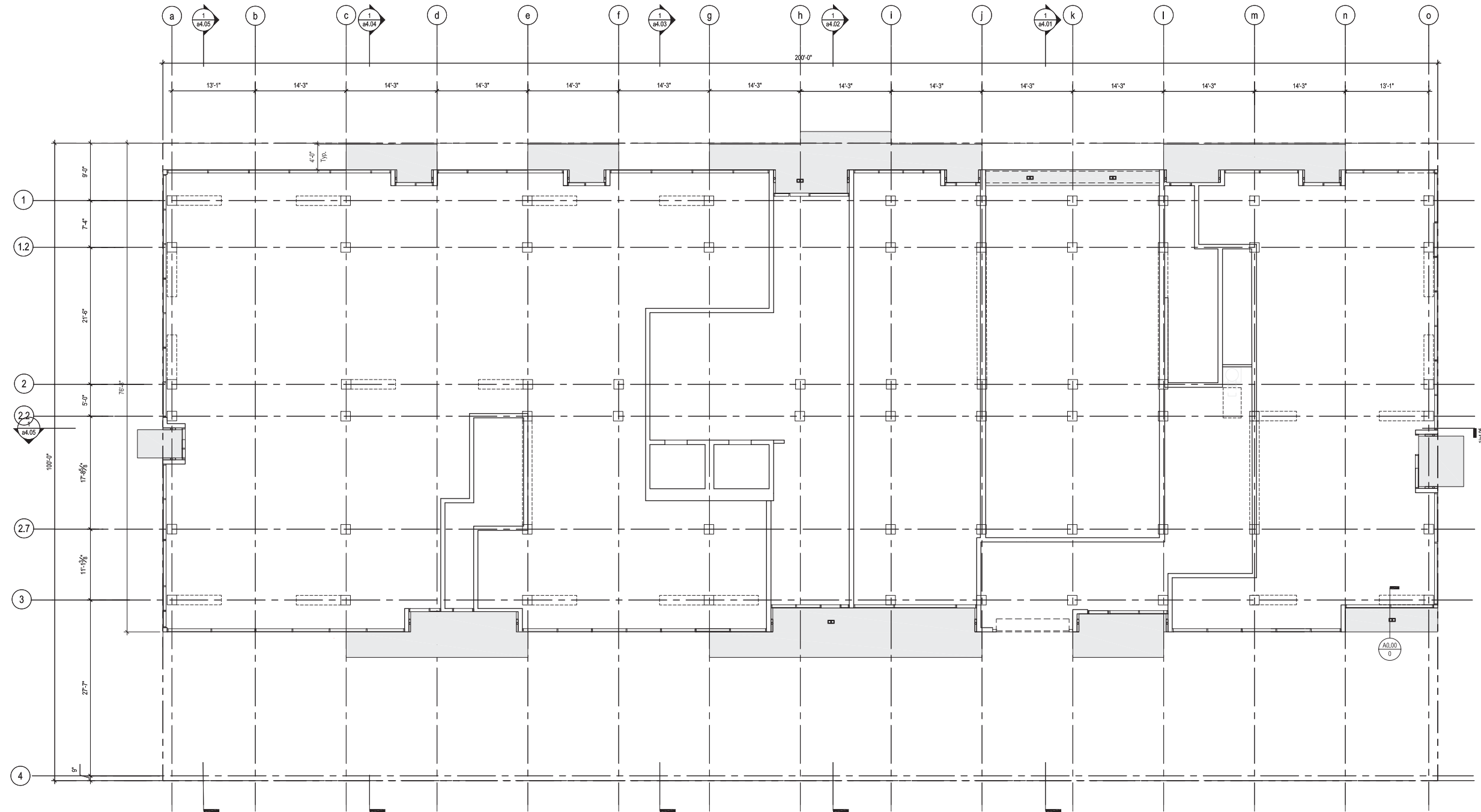

RCP: CANOPIES AND EXTERIOR LIGHTING

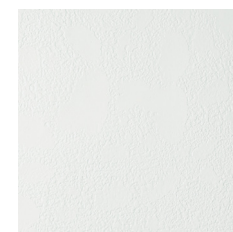

1. STUCCO



2. GLASS

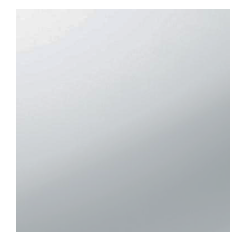

3. SPANDREL GLASS

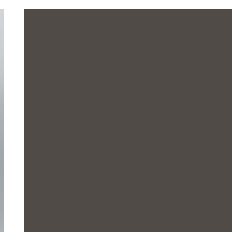

4. ACM METAL PANEL

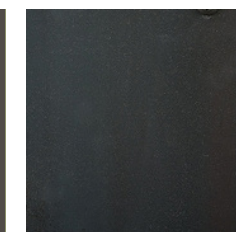

4. STEEL SIDINGS

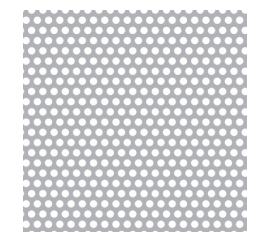

6. METAL SCREEN

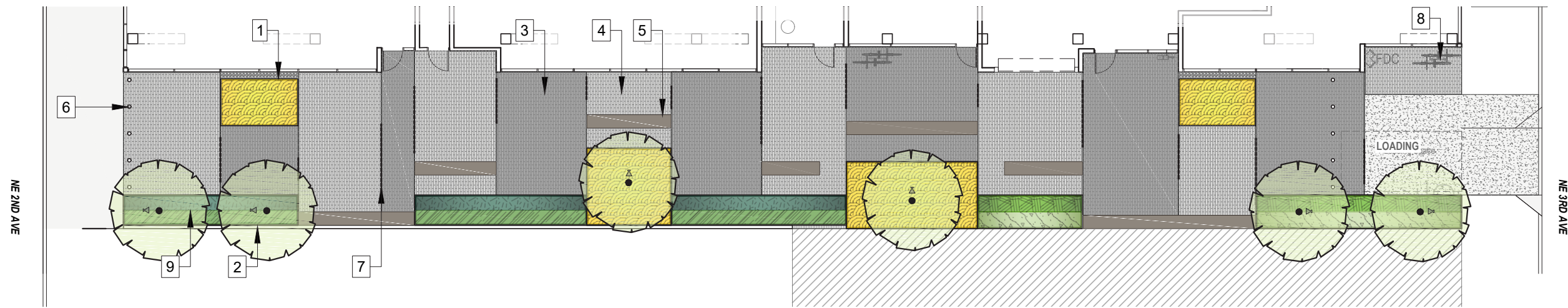

1 6 STORY BUILDING - PLAZA MATERIALS PLAN ENLARGEMENT



1 16" STEEL PLANTER  
(SEE DETAIL 2)



2 30" STEEL PLANTER  
(SEE DETAIL 2)



3 PERMEABLE PAVER  
TYPE 1

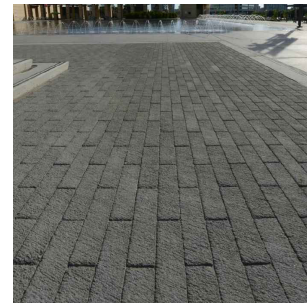

4 PERMEABLE PAVER  
TYPE 2



5 BENCH (SEE DETAIL 1)

NOTE:  
TO SEE DETAILS REFER TO LANDSCAPE  
DETAILS SHEET

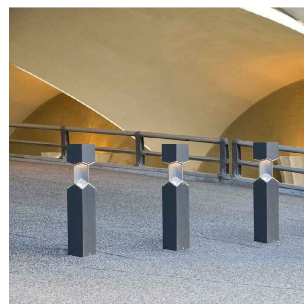

6 BOLLARD

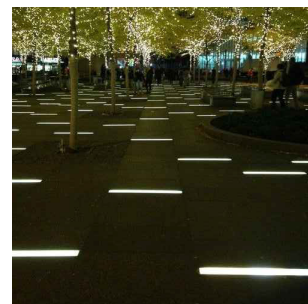

7 LED PAVING LIGHT  
STRIP (SEE DETAIL 3)



8 BIKE RACK



9 UPLIGHTING



SITE KEY  
NTS

LANDSCAPE LIGHTING DETAILS

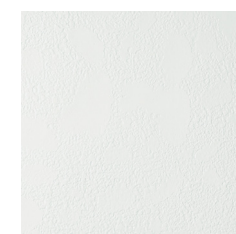

1. STUCCO



2. GLASS



3. SPANDREL GLASS



4. ACM METAL PANEL

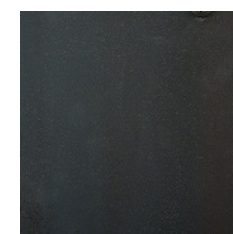

4. STEEL SIDINGS

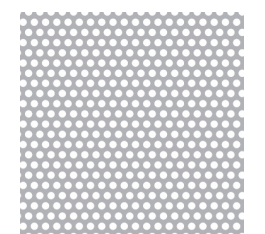

6. METAL SCREEN



SOUTHWEST CORNER, GROUND LEVEL

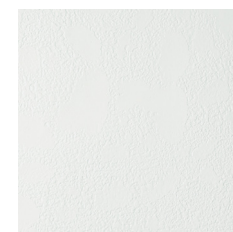

1. STUCCO



2. GLASS

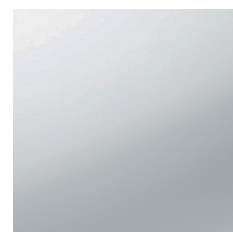

3. SPANDREL GLASS



4. ACM METAL PANEL

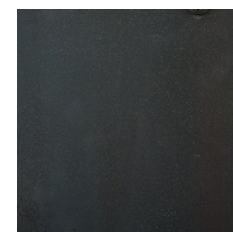

4. STEEL SIDINGS

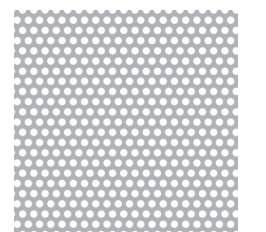

6. METAL SCREEN



SOUTHEAST CORNER, GROUND LEVEL

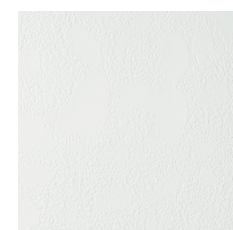

1. STUCCO



2. GLASS



3. SPANDREL GLASS



4. ACM METAL PANEL

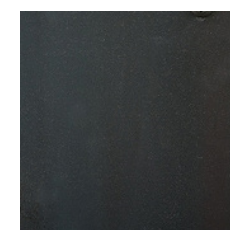

4. STEEL SIDINGS

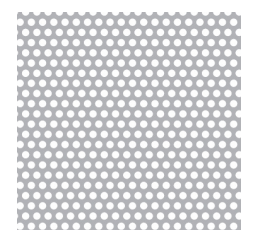

6. METAL SCREEN





## 6 AND 9 STORY NORTH ELEVATION



# APPENDIX

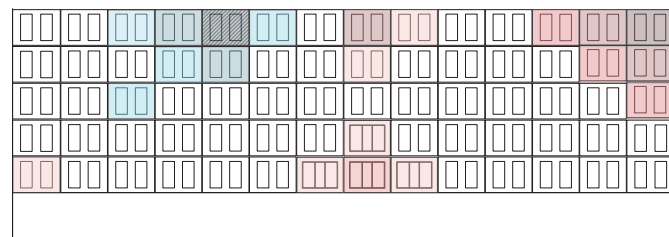

North Elevation Diagram

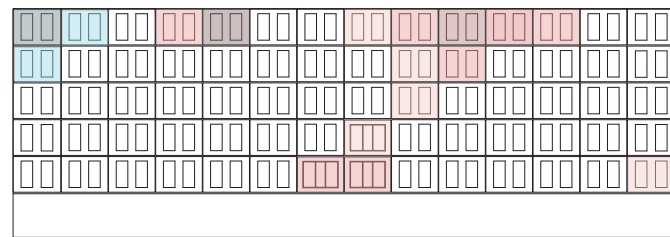

South Elevation Diagram

# SOUTH ELEVATION

6 STORY

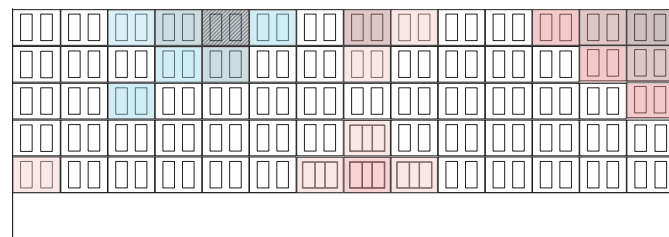

North Elevation Diagram

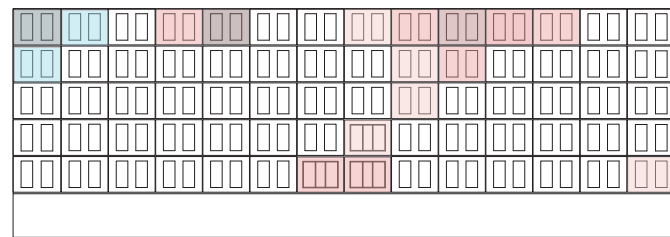

South Elevation Diagram

# NORTH ELEVATION

6 STORY

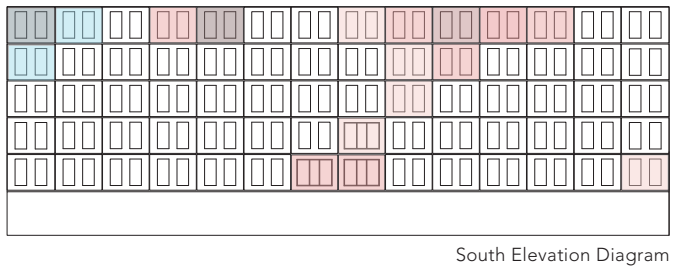
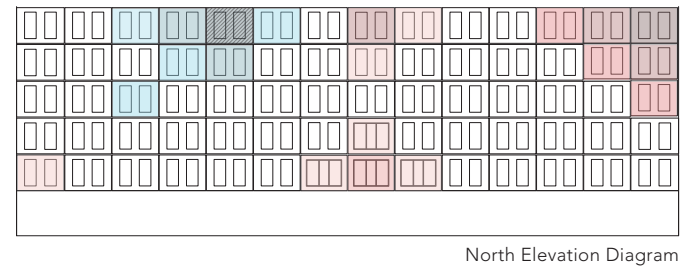
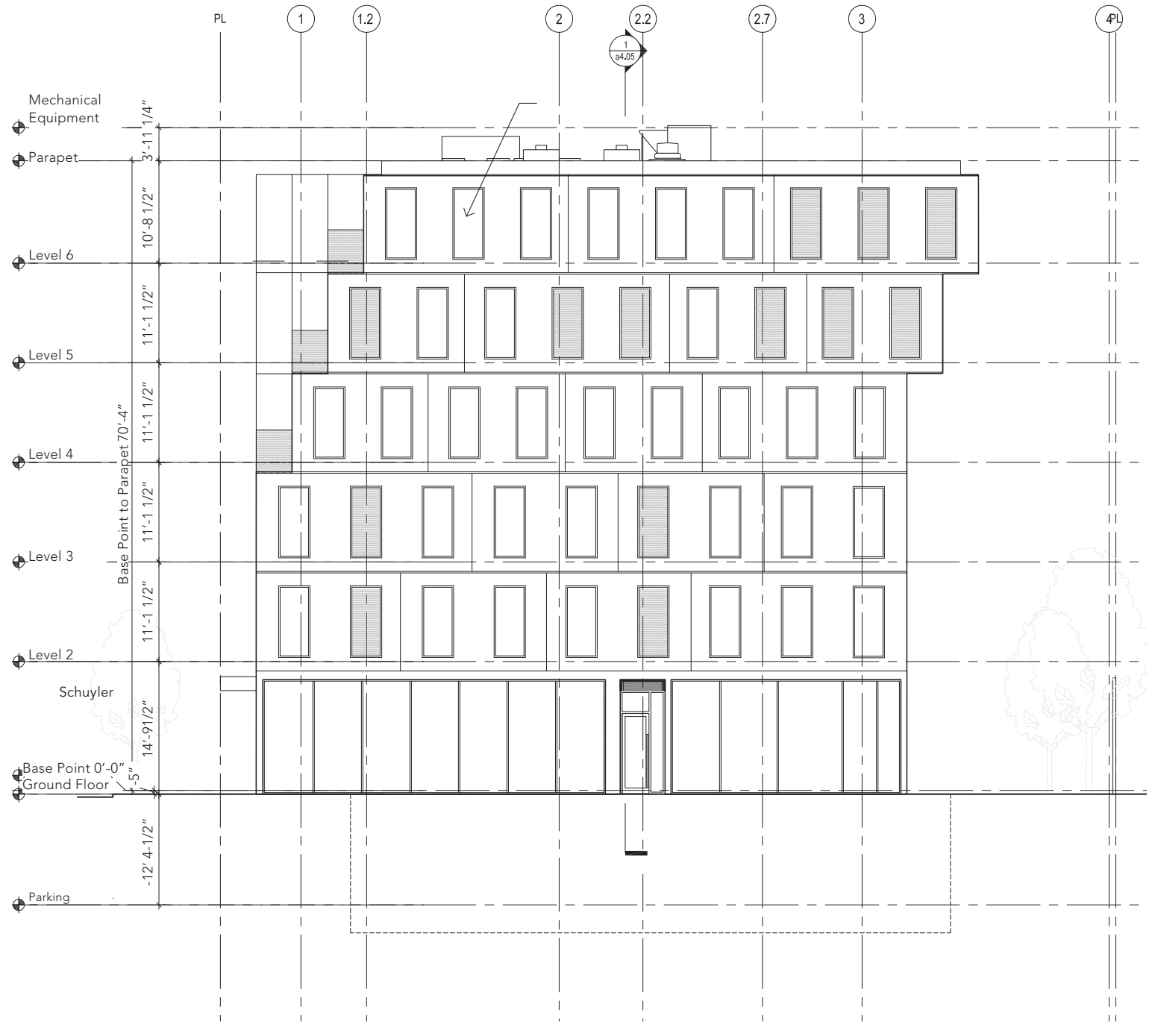
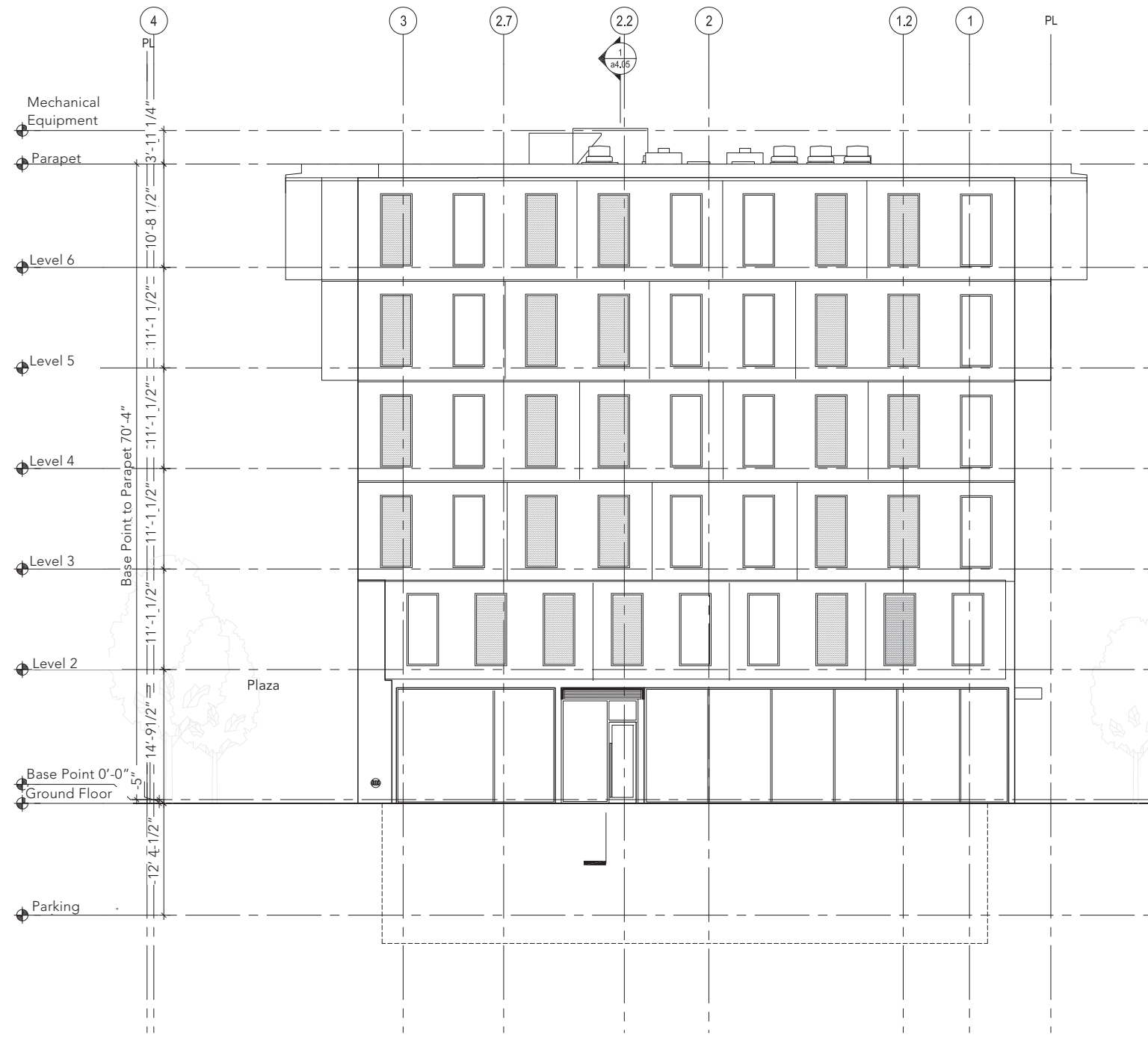

# EAST AND WEST ELEVATION

6 STORY

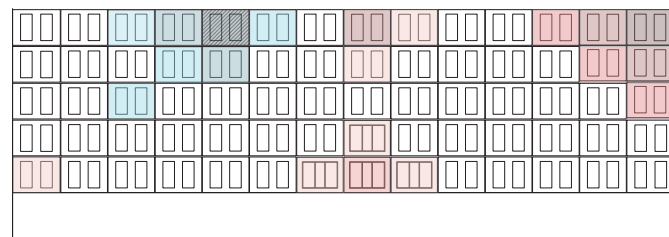

North Elevation Diagram

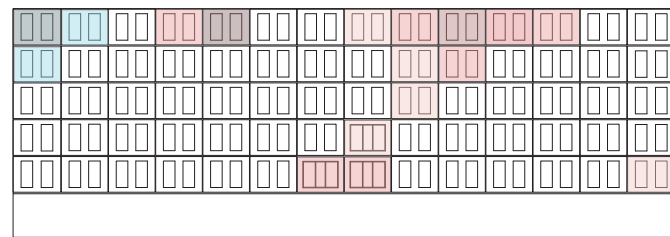

South Elevation Diagram

# SOUTH ELEVATION

## STRUCTURE DIAGRAM

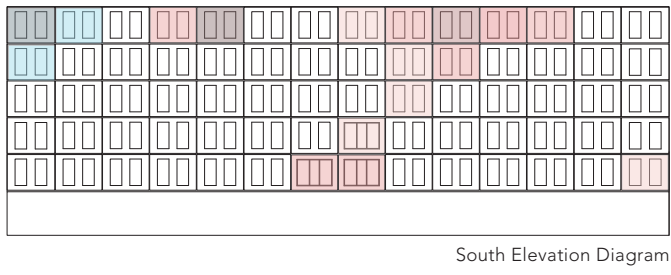
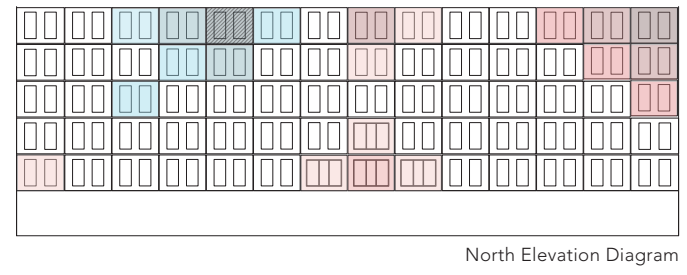

# NORTH ELEVATION

## STRUCTURE DIAGRAM



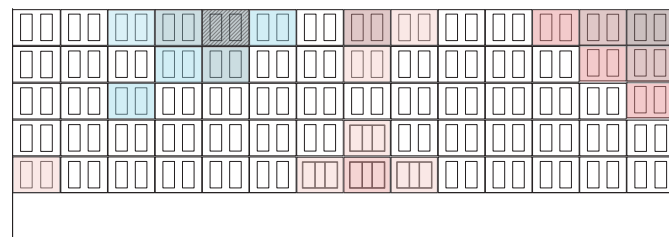
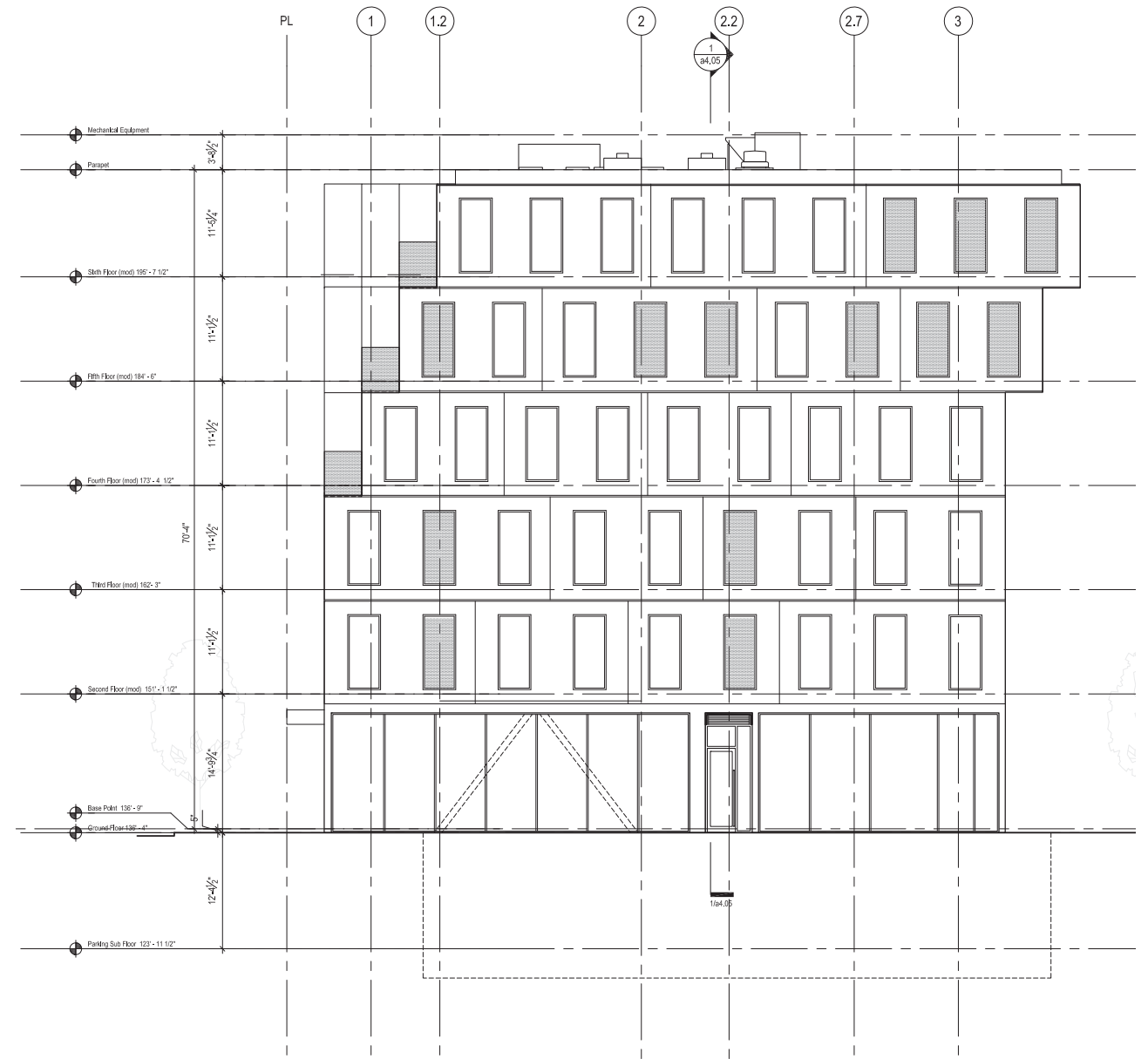
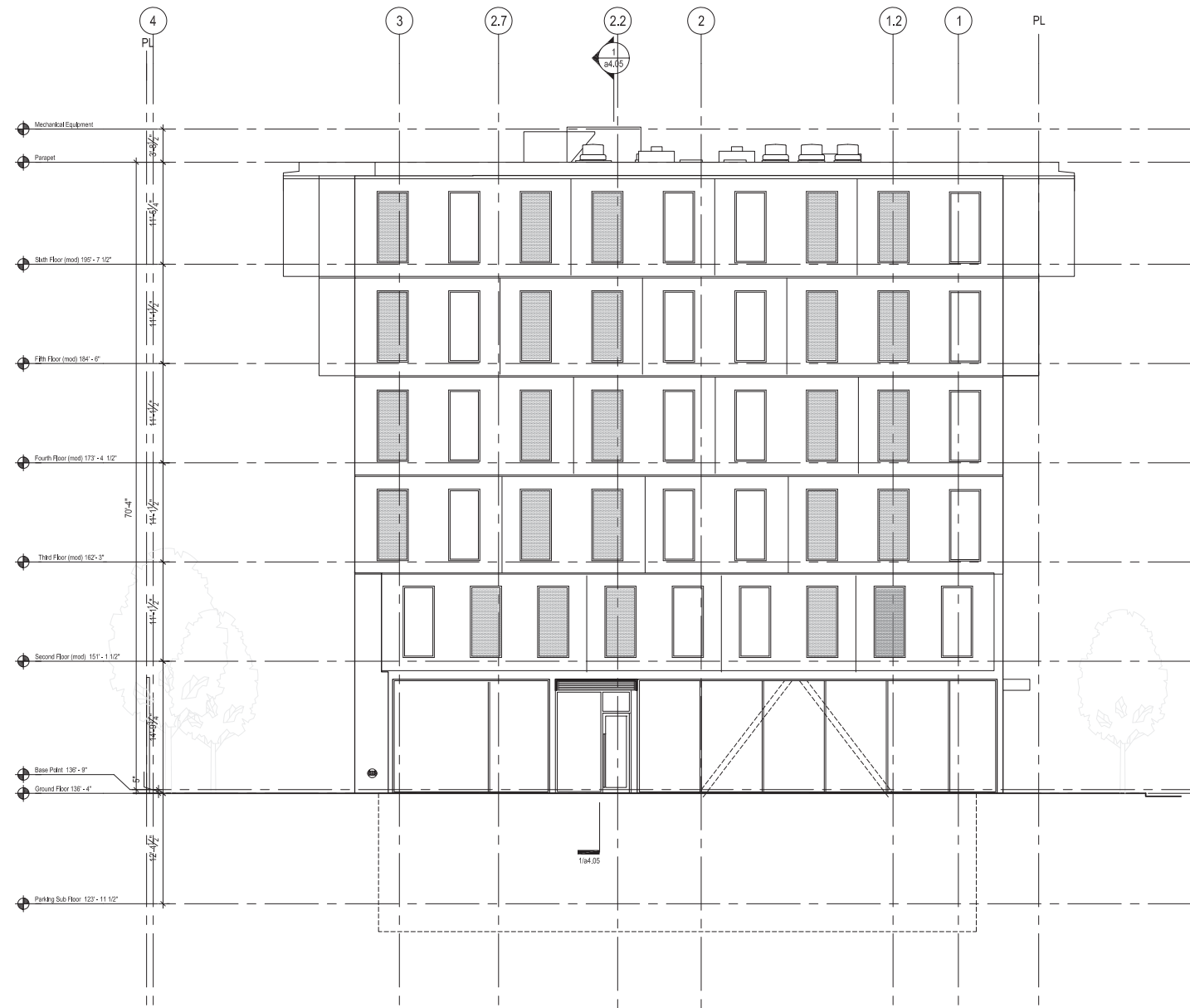

North Elevation Diagram

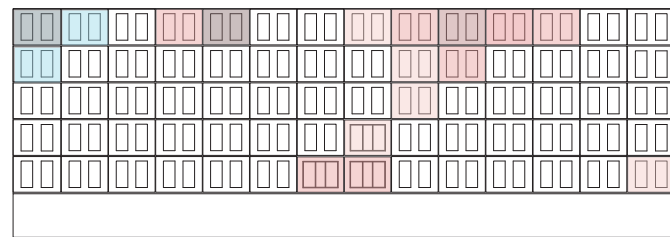

South Elevation Diagram

# EAST AND WEST ELEVATION

## STRUCTURE DIAGRAM

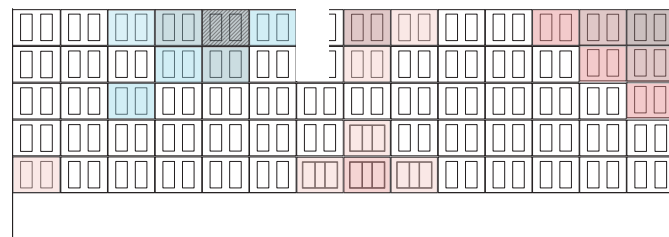

North Elevation Diagram

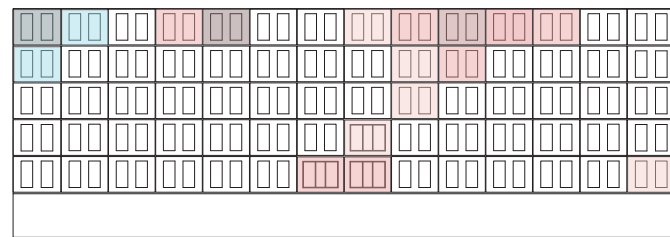

South Elevation Diagram

# SOUTH ELEVATION

9 STORY

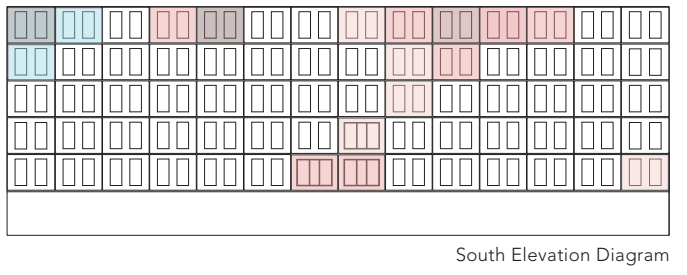
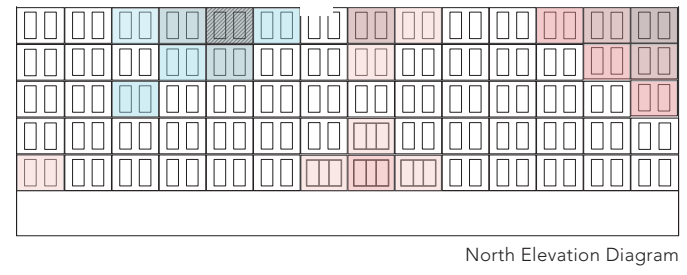

# NORTH ELEVATION

9 STORY

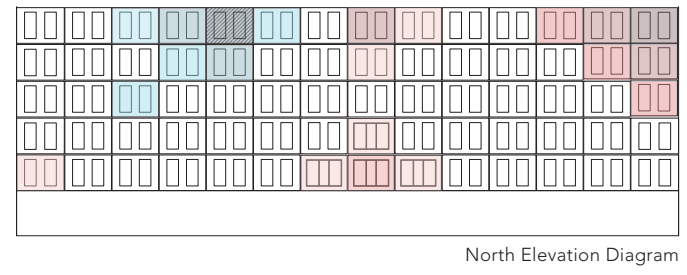

North Elevation Diagram

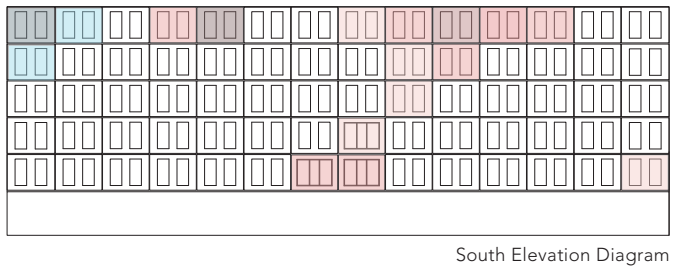

South Elevation Diagram

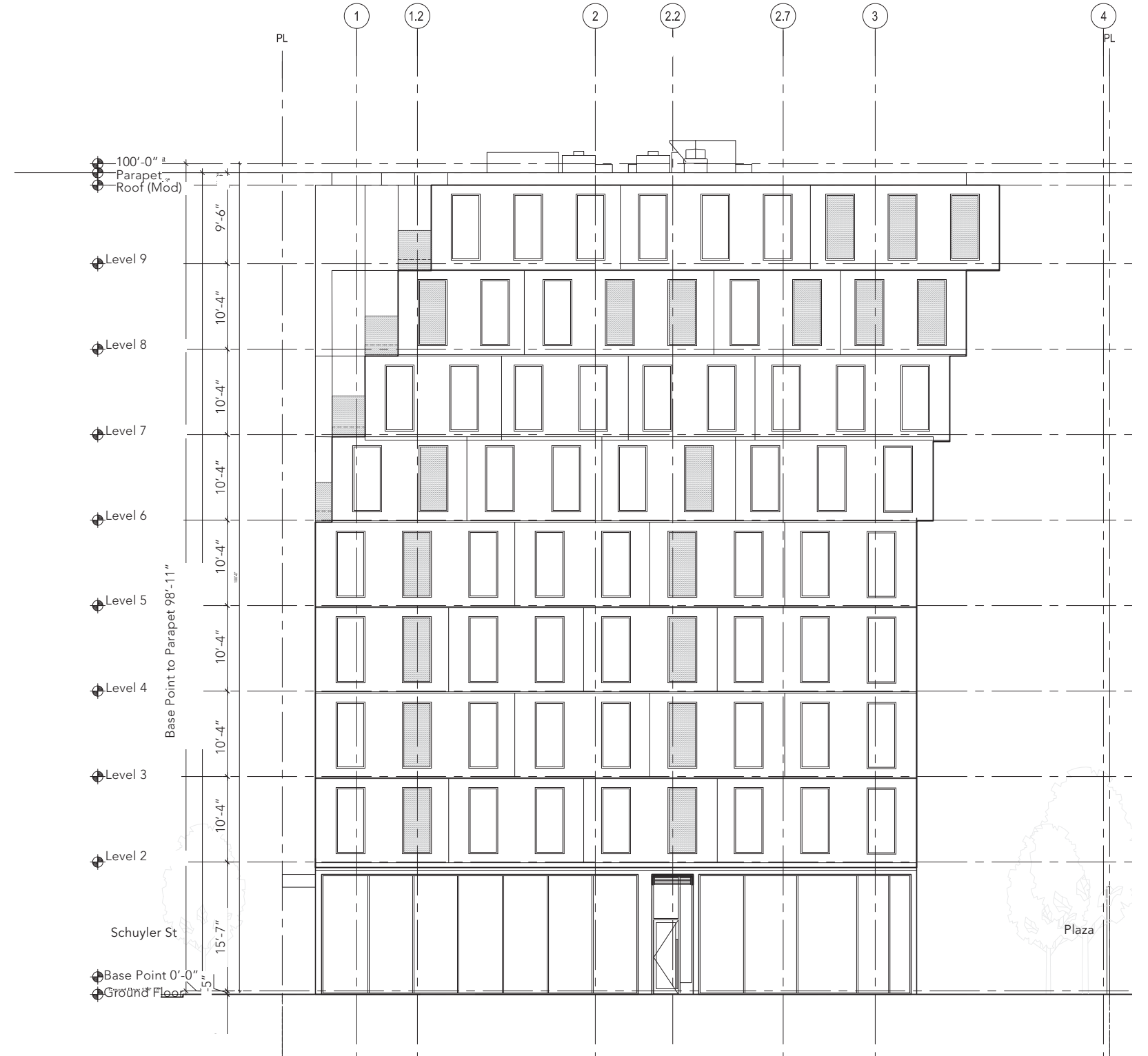

# EAST AND WEST ELEVATIONS

9 STORY

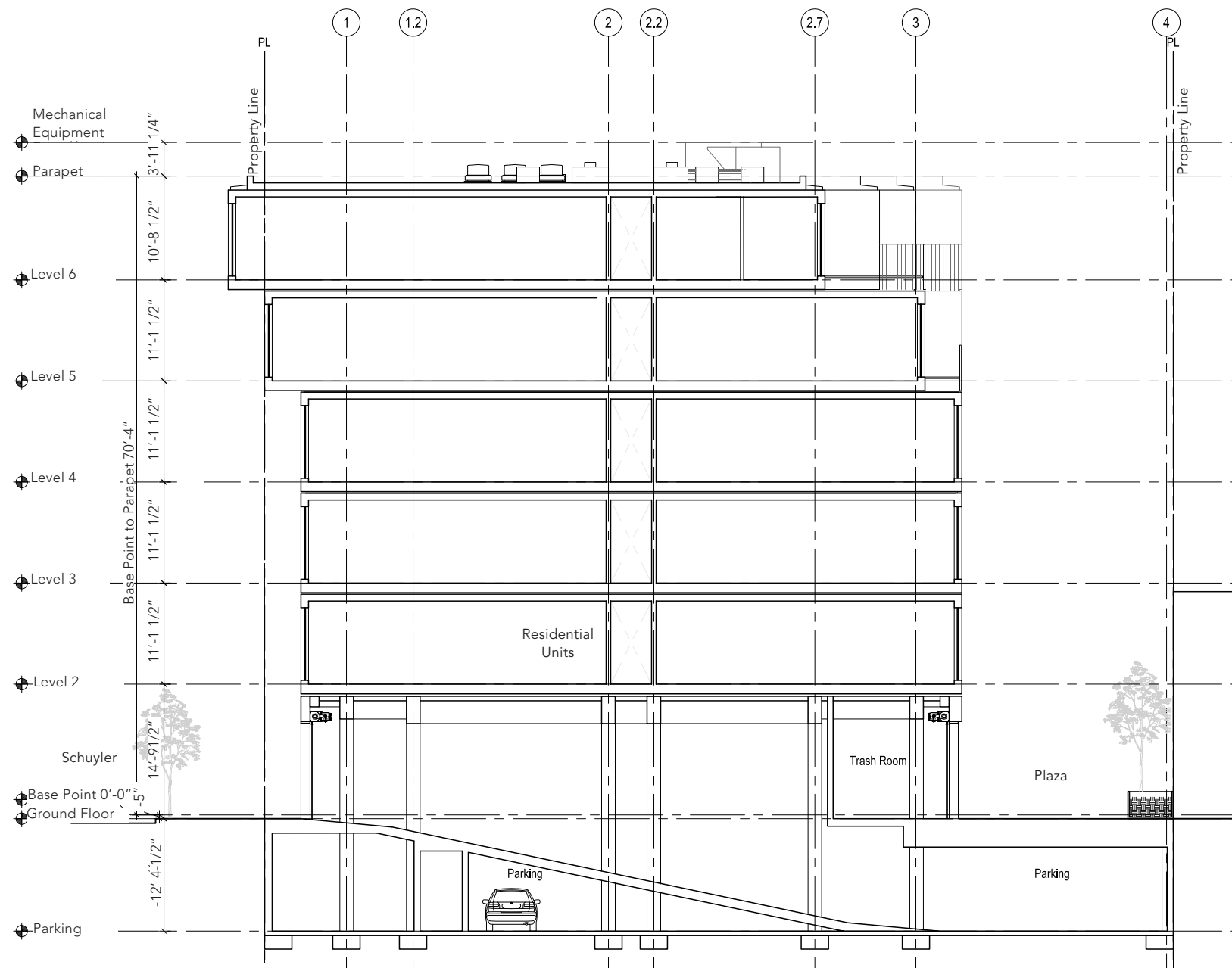

BUILDING SECTION THROUGH WEST UNITS

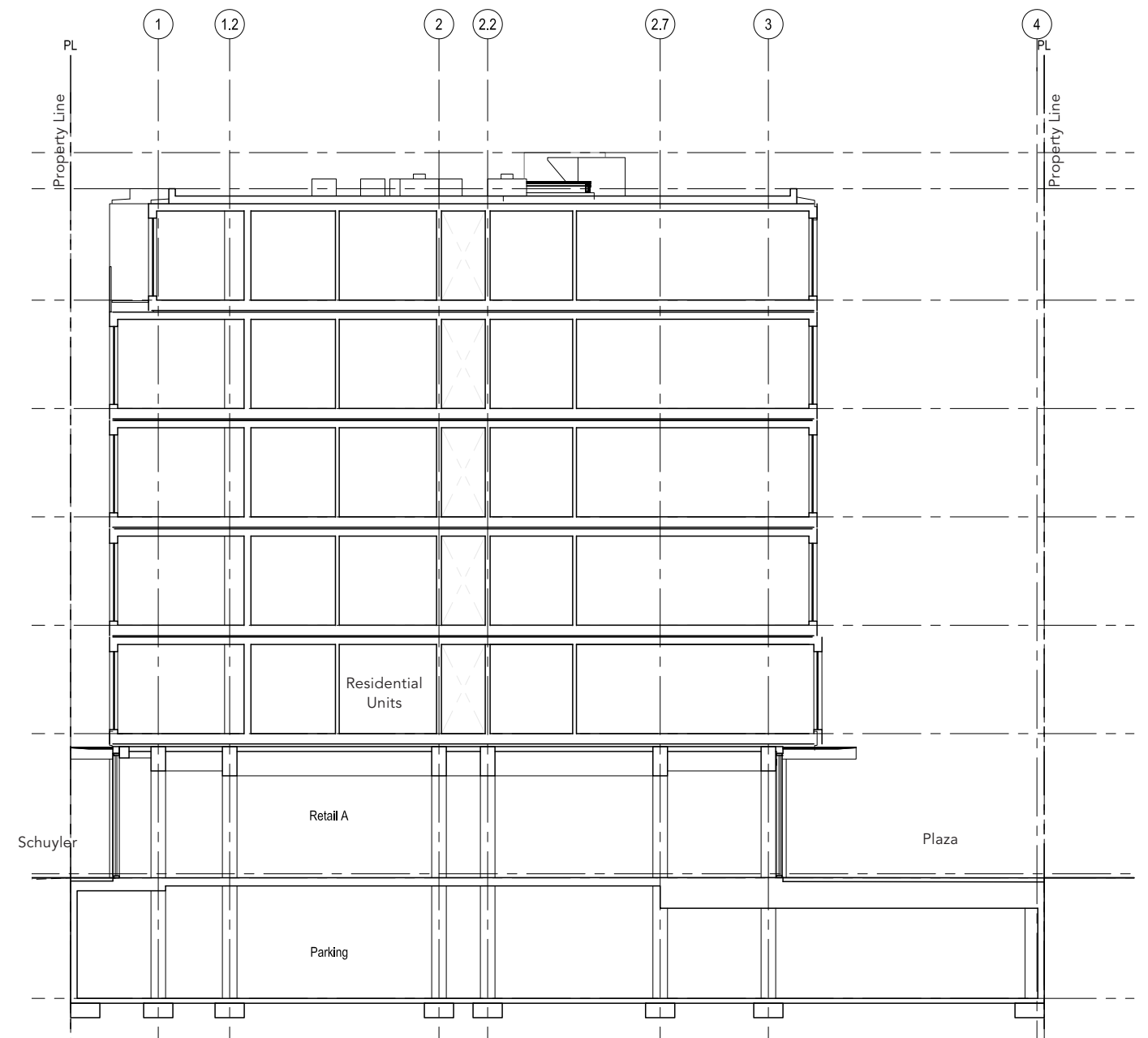

BUILDING SECTION THROUGH RETAIL ENTRANCES

# BUILDING SECTIONS

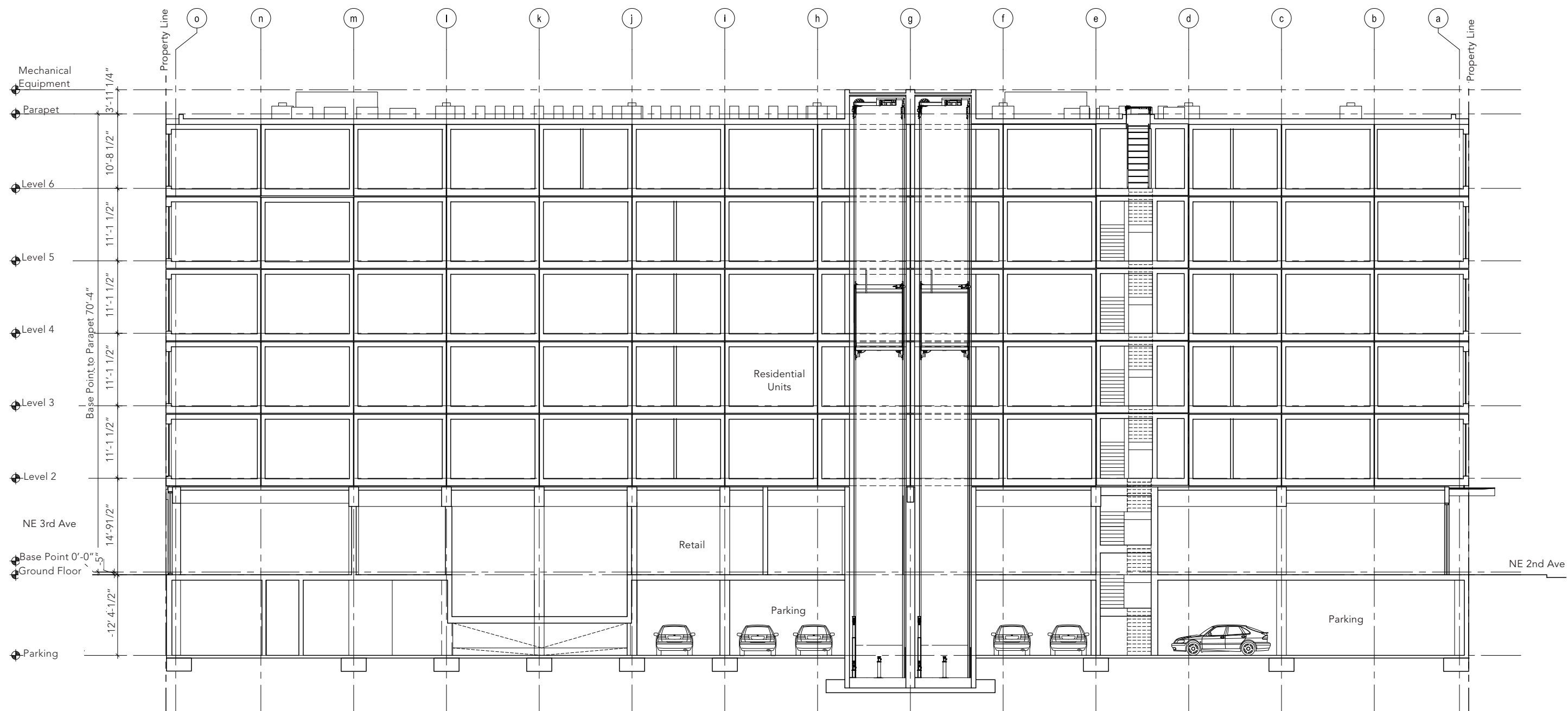

# BUILDING SECTIONS



NORTH ELEVATION

# FLOOR PLANS



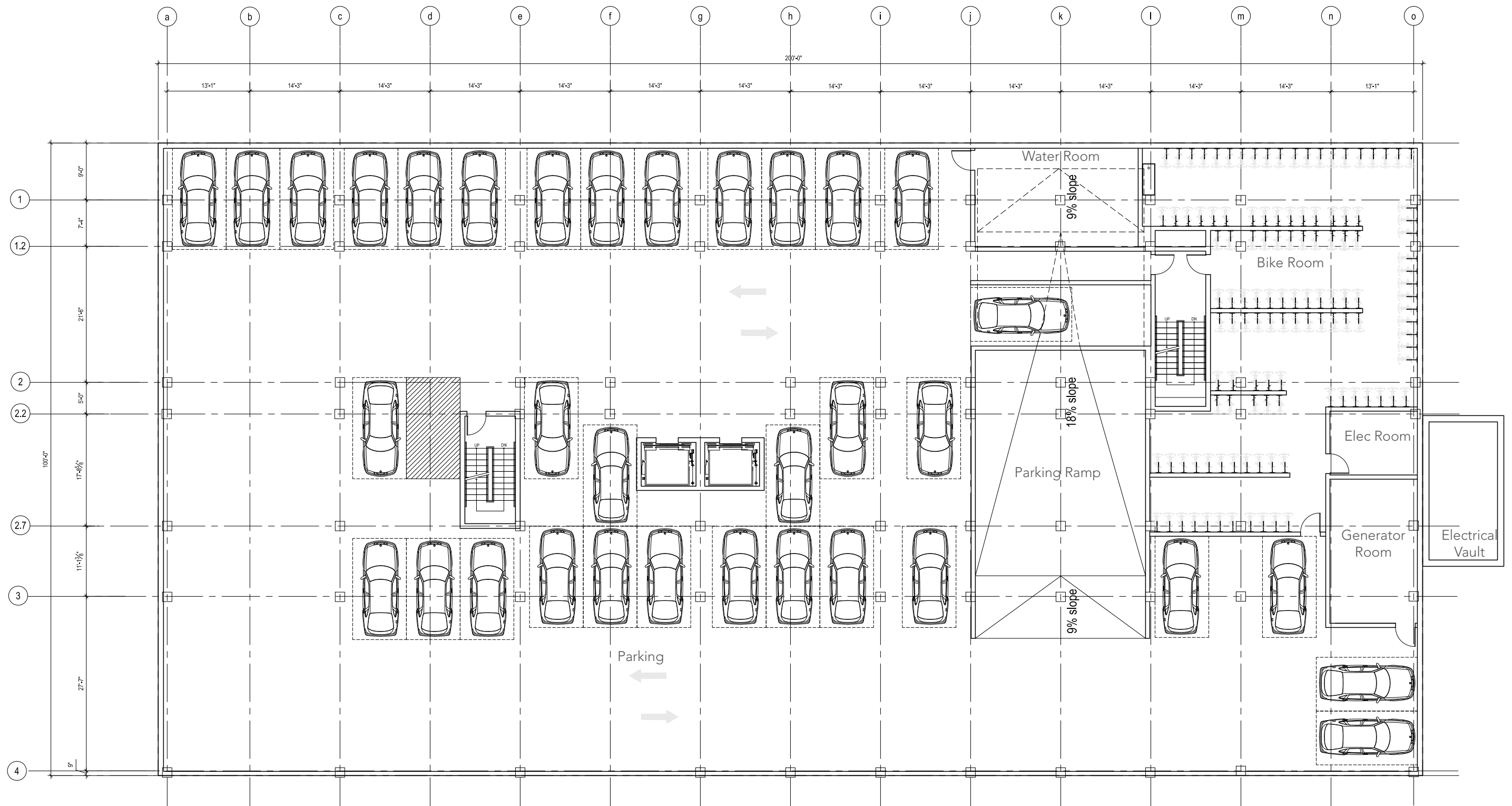

# 6 STORY BASEMENT PLAN

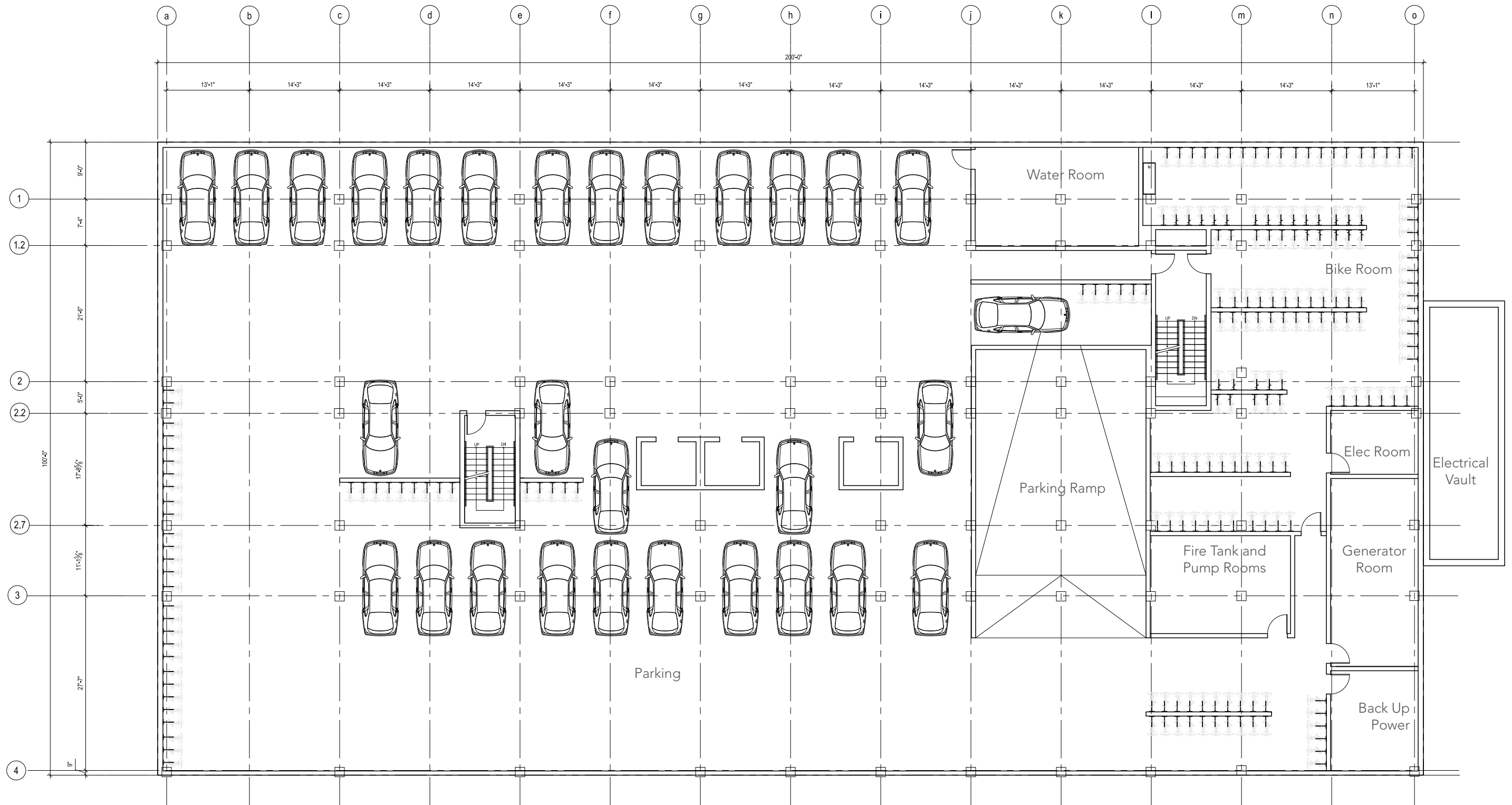

# 9 STORY BASEMENT PLAN

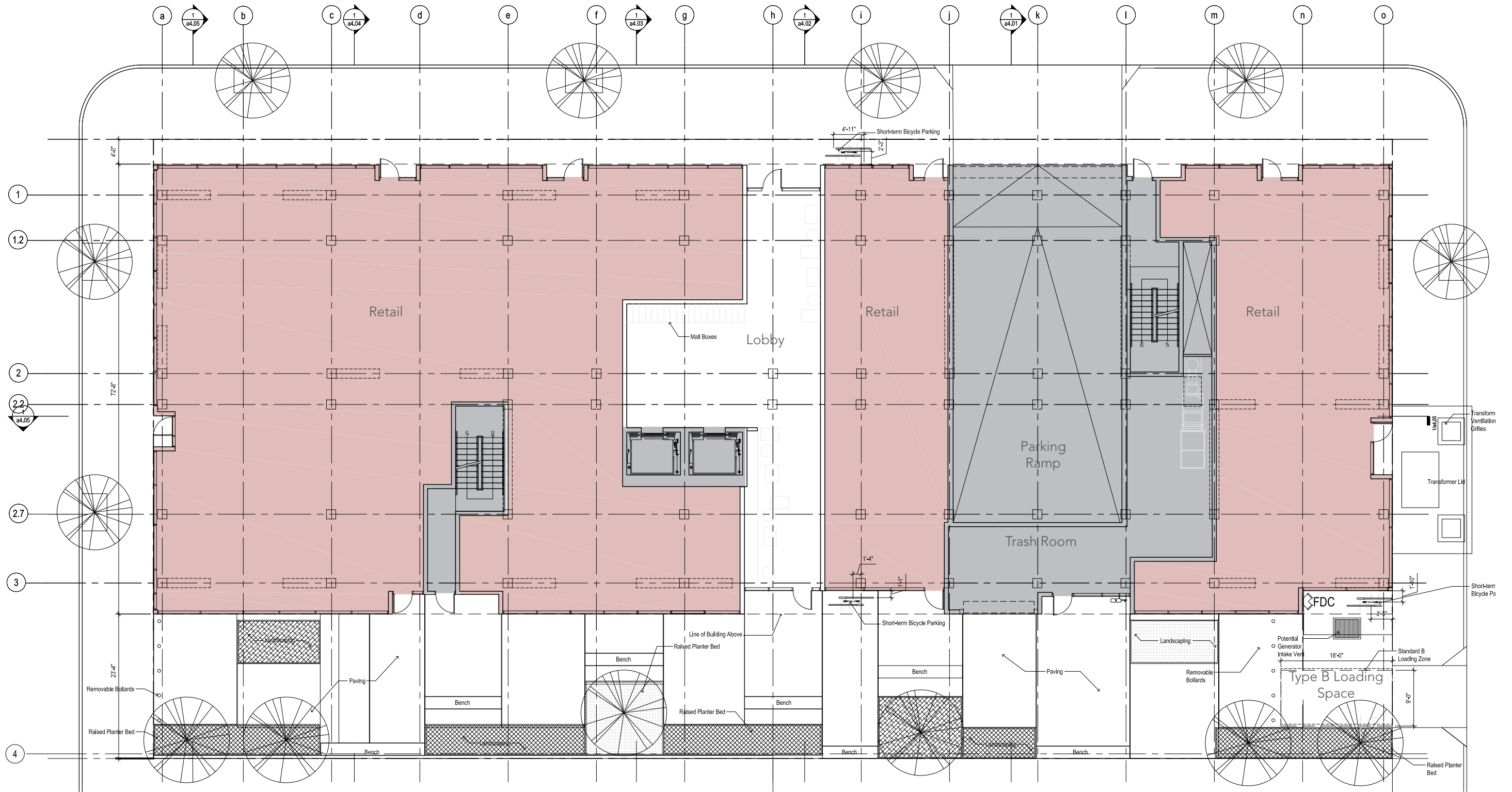

# 6 STORY GROUND FLOOR PLAN

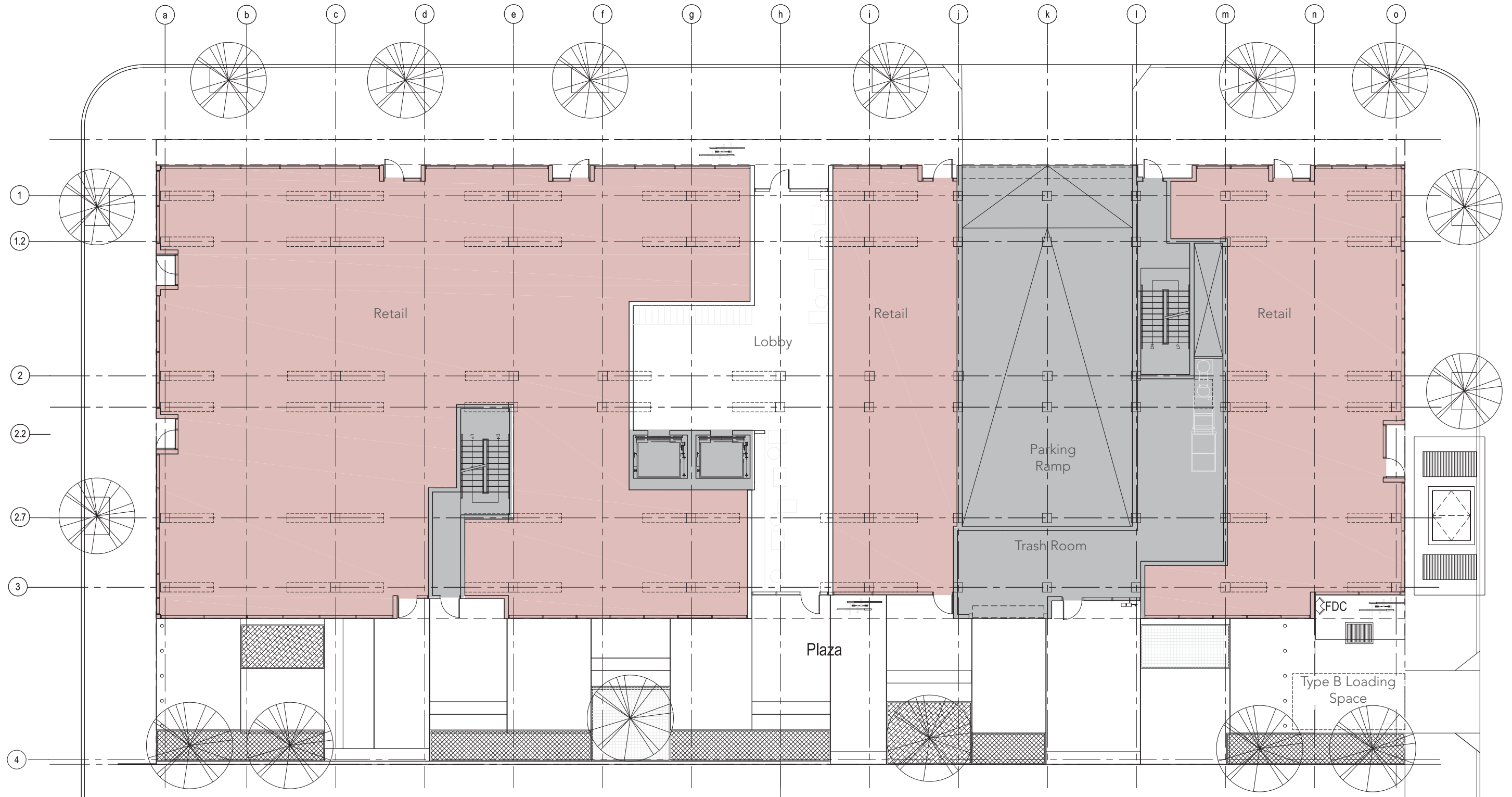

## PREVIOUS 6 STORY GROUND FLOOR

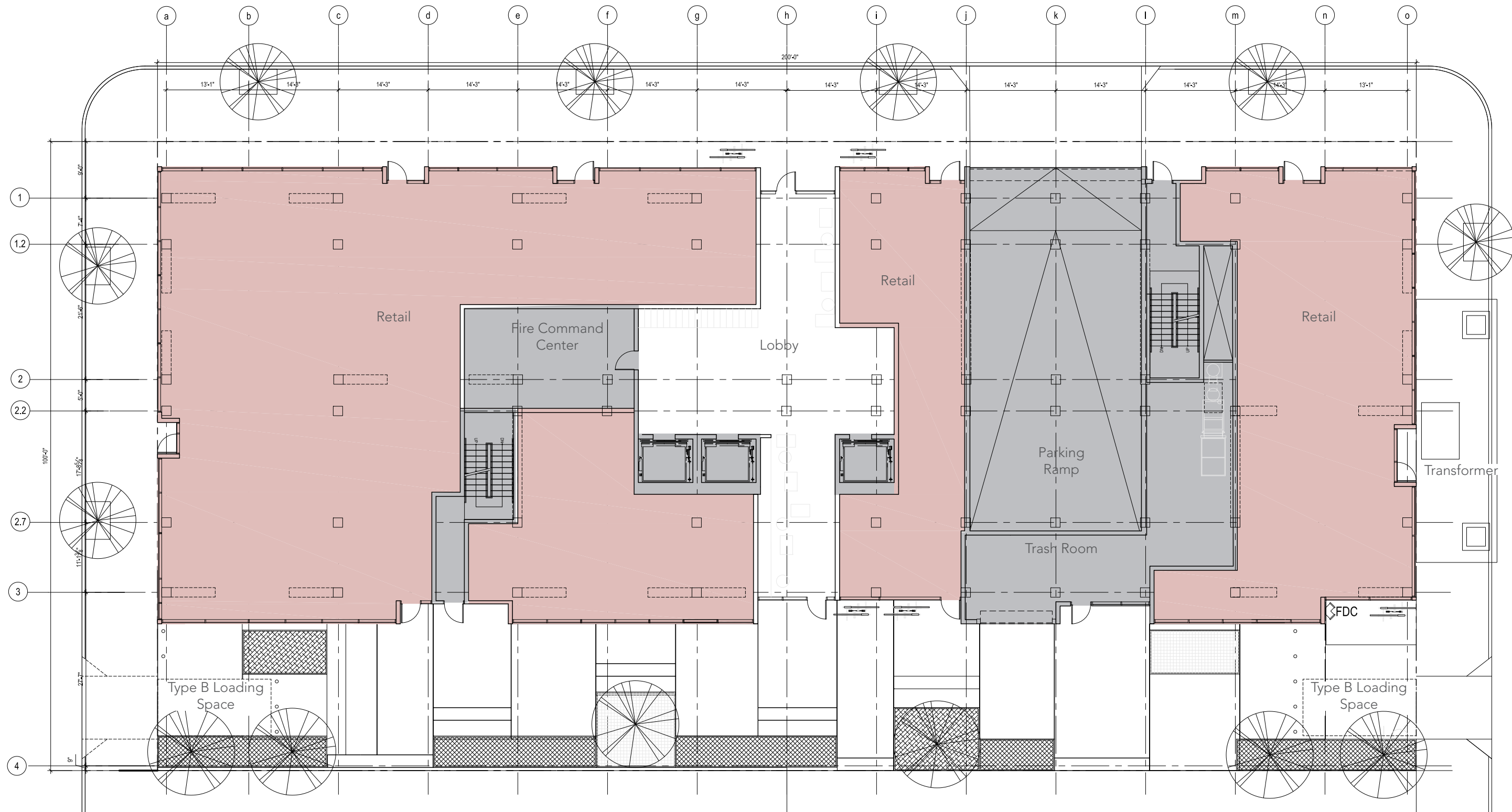

# 9 STORY GROUND FLOOR PLAN



- 2 Bedroom Unit
- 1 Bedroom Unit
- Studio

# 6 STORY SECOND FLOOR PLAN

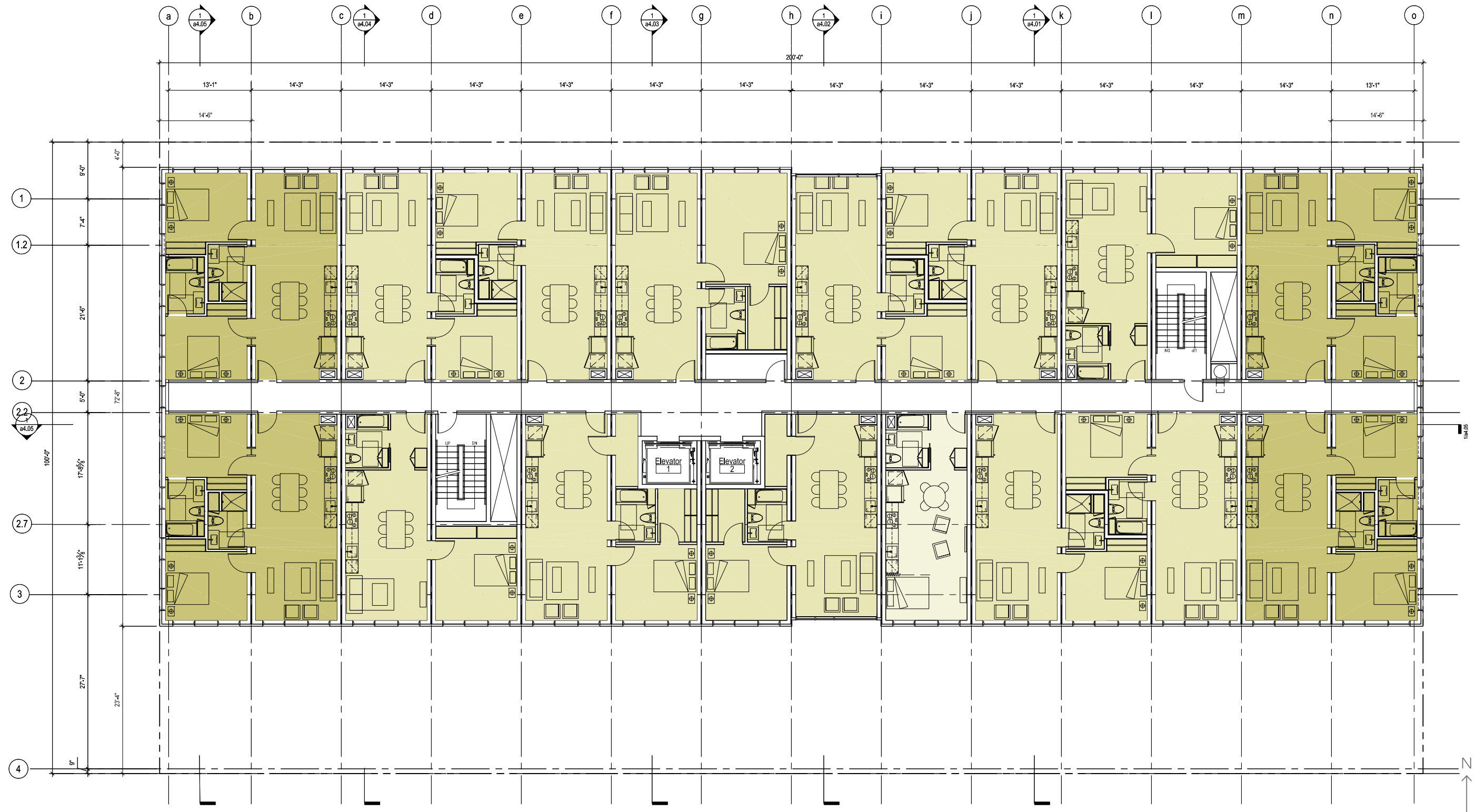

- 2 Bedroom Unit
- 1 Bedroom Unit
- Studio

# 6 STORY THIRD FLOOR PLAN

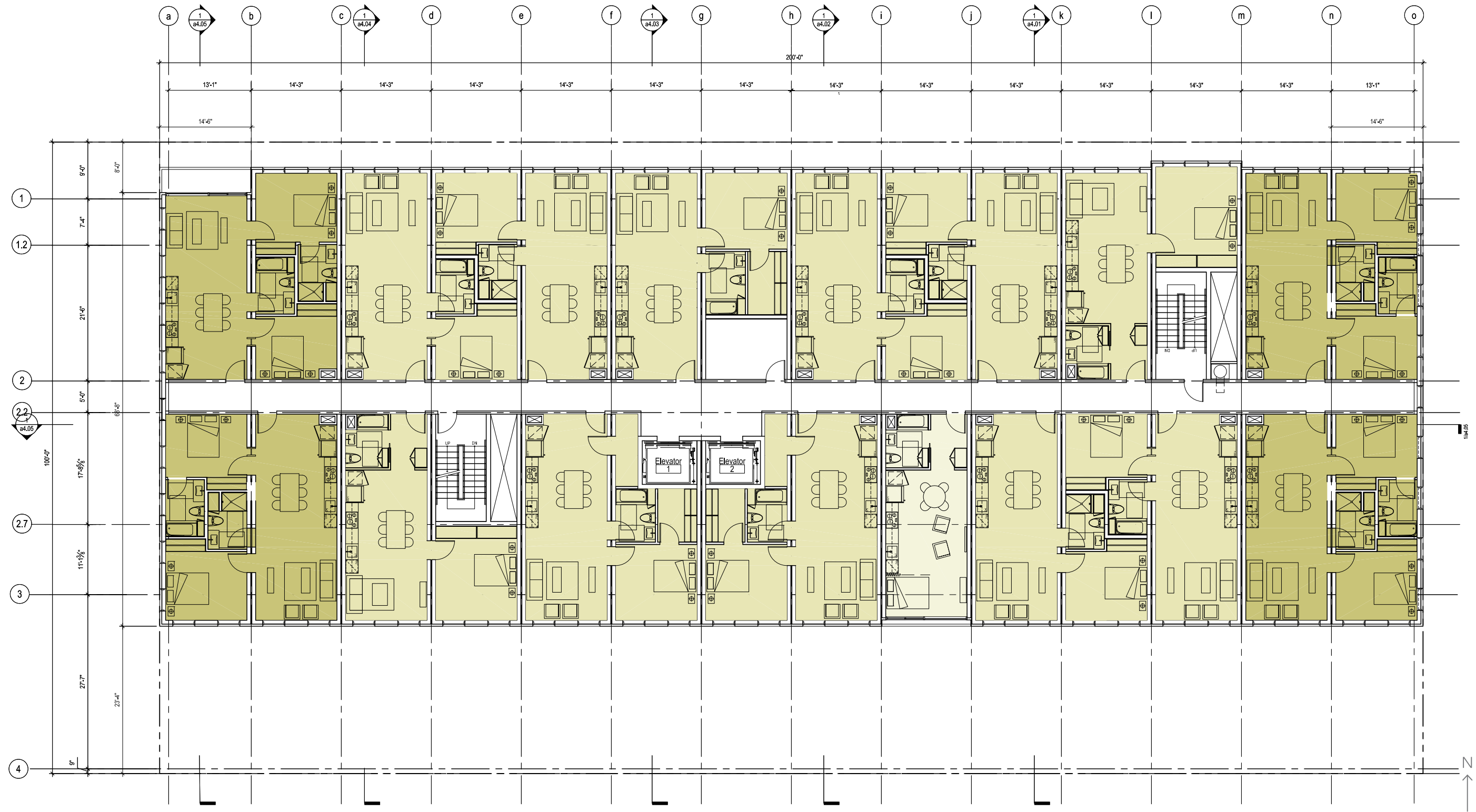

- 2 Bedroom Unit
- 1 Bedroom Unit
- Studio

# 6 STORY FOURTH FLOOR PLAN





- 2 Bedroom Unit
- 1 Bedroom Unit
- Studio

# 6 STORY FIFTH FLOOR PLAN



- 2 Bedroom Unit
- 1 Bedroom Unit
- Studio
- Common Space

# 6 STORY SIXTH FLOOR PLAN

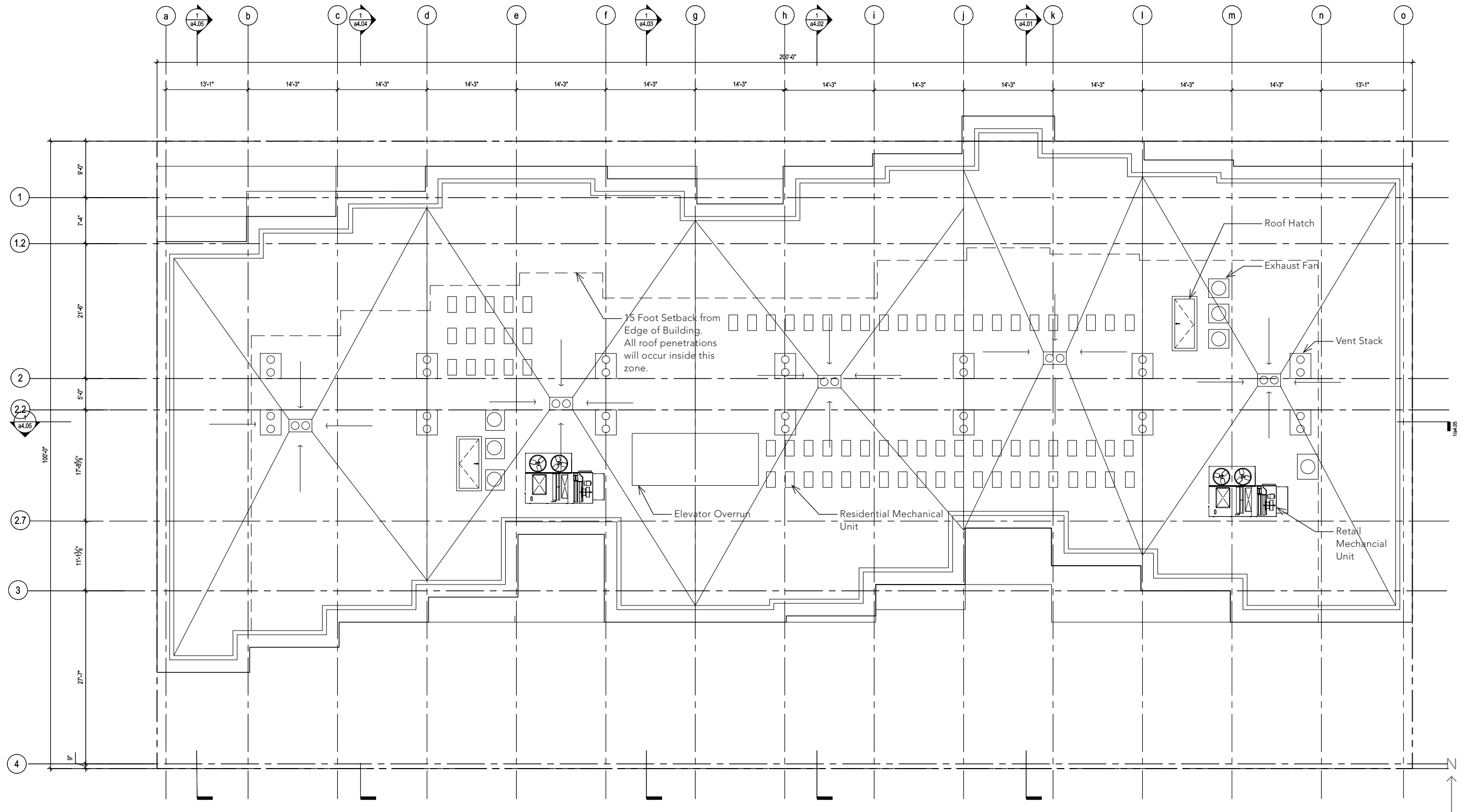

# 6 STORY ROOF PLAN

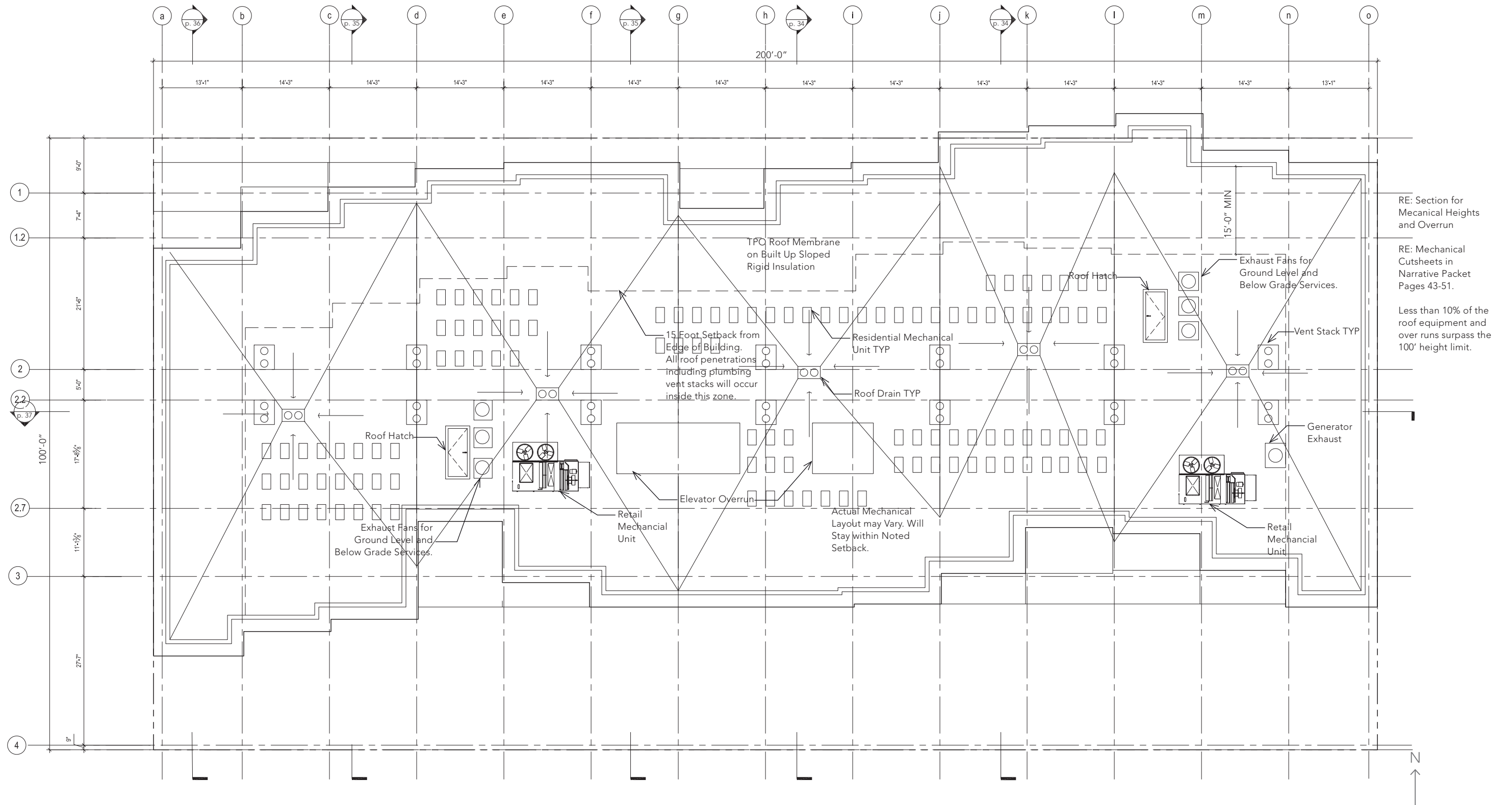

# 9 STORY ROOF PLAN



## CONTEXT IMAGES

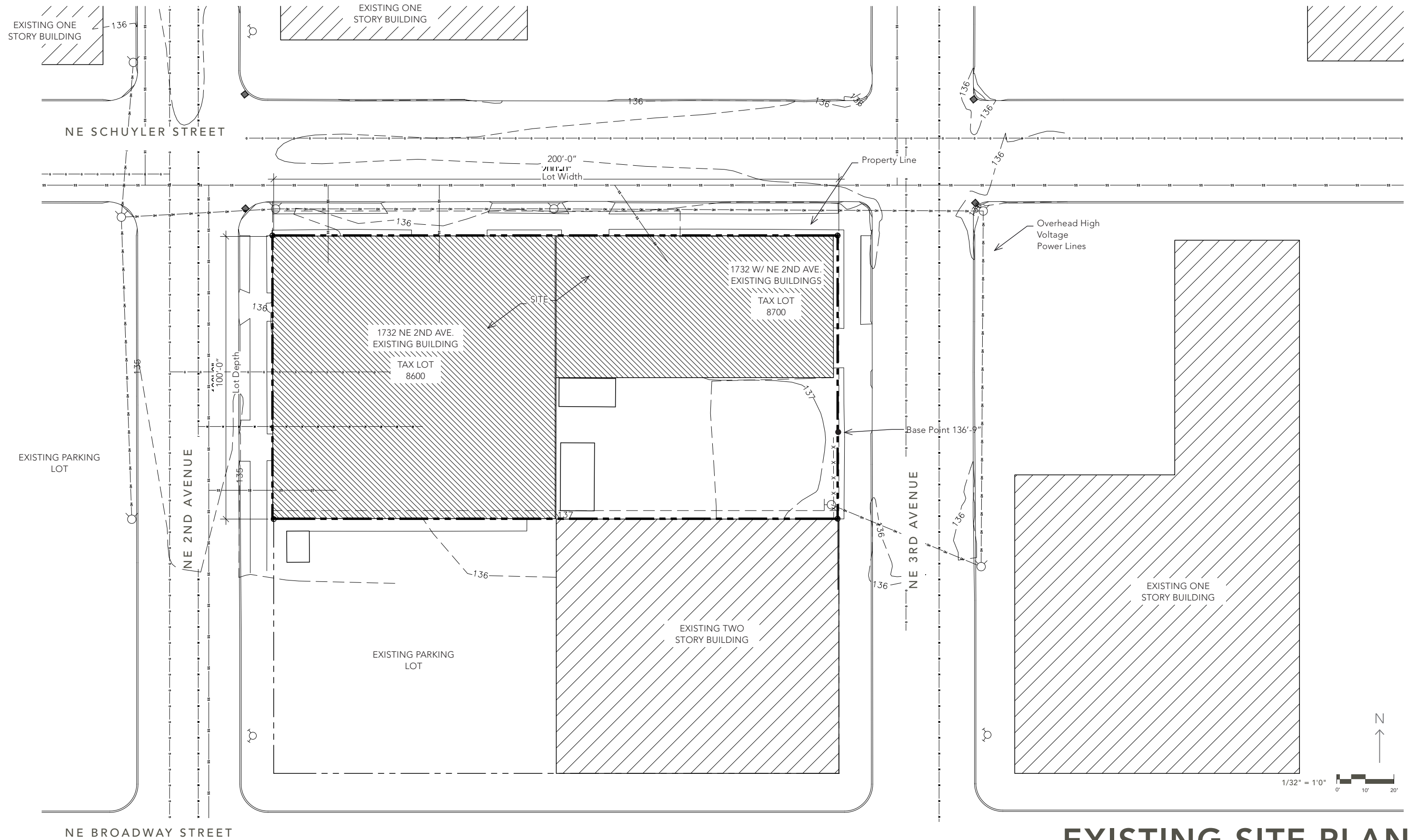

# EXISTING SITE PLAN

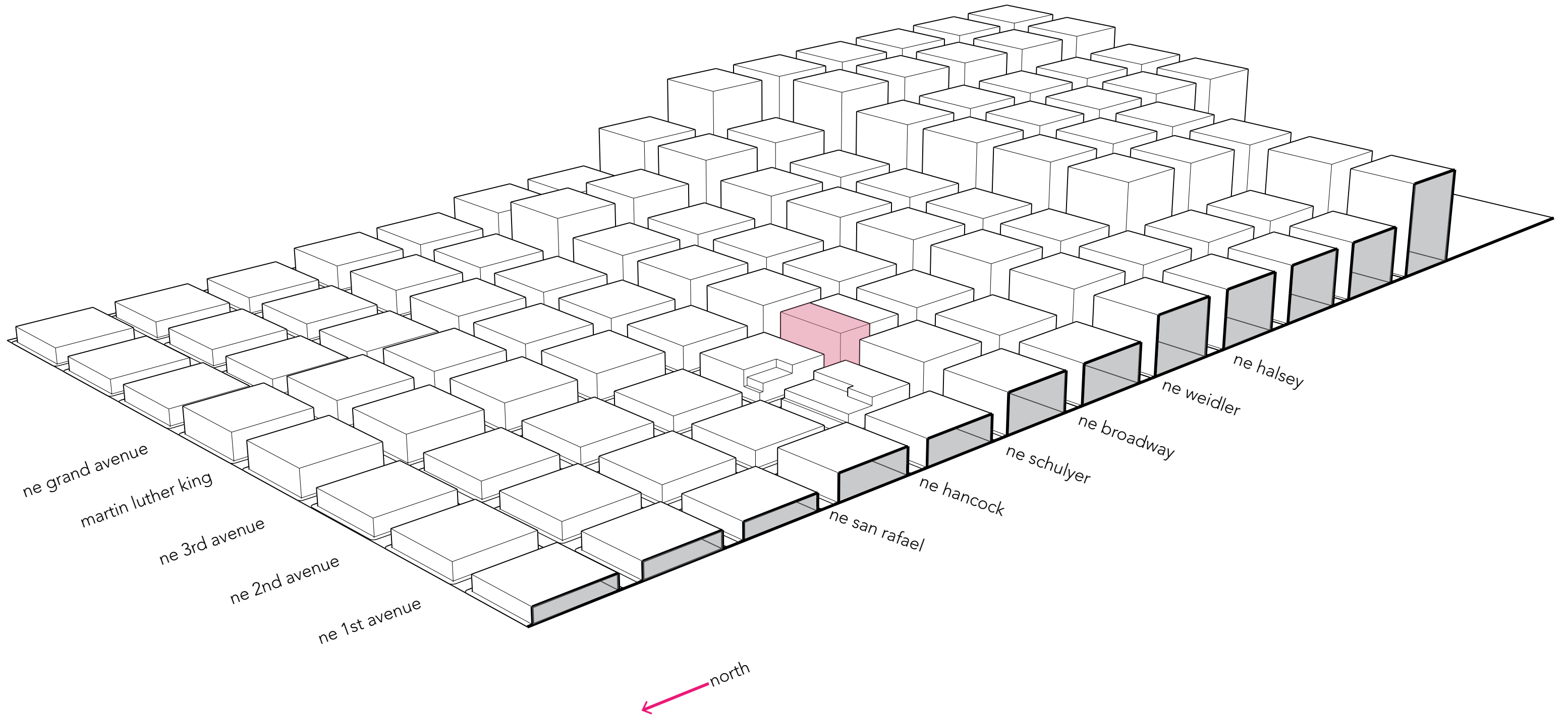

# ZONING RELATIONSHIPS

Lloyd District

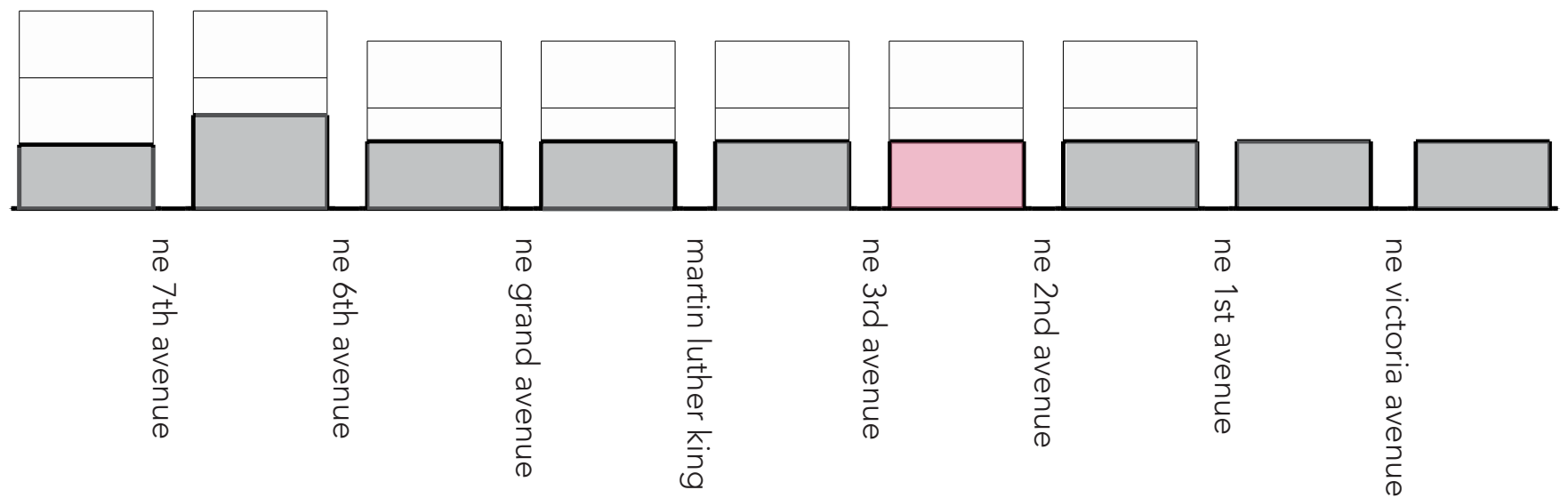
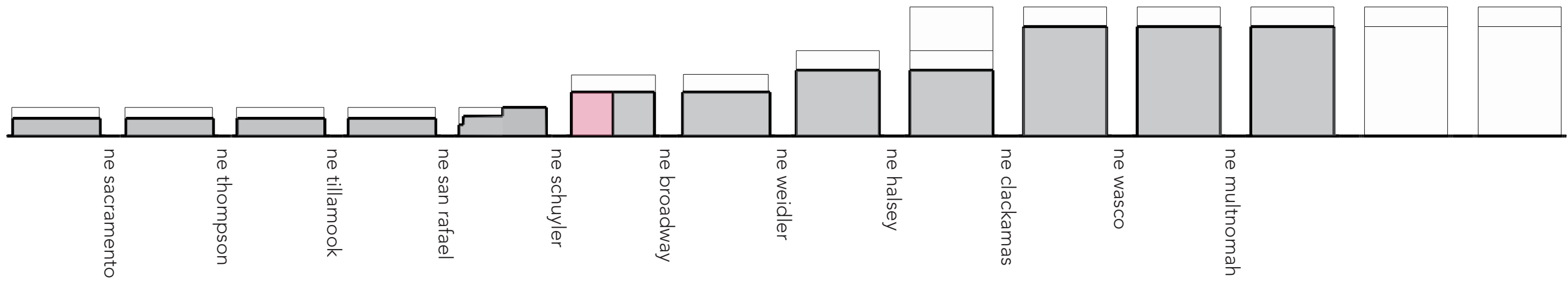

# ZONING RELATIONSHIPS

Lloyd District