



NEUBERGER HALL

Type III Design Review Hearing | August 03, 2017

PORTLAND STATE UNIVERSITY

HACKER



CAMPUS MAP

TWO BUILDINGS - PARK BLOCKS + BROADWAY



PSU URBAN CENTER



SOUTH PARK BLOCKS

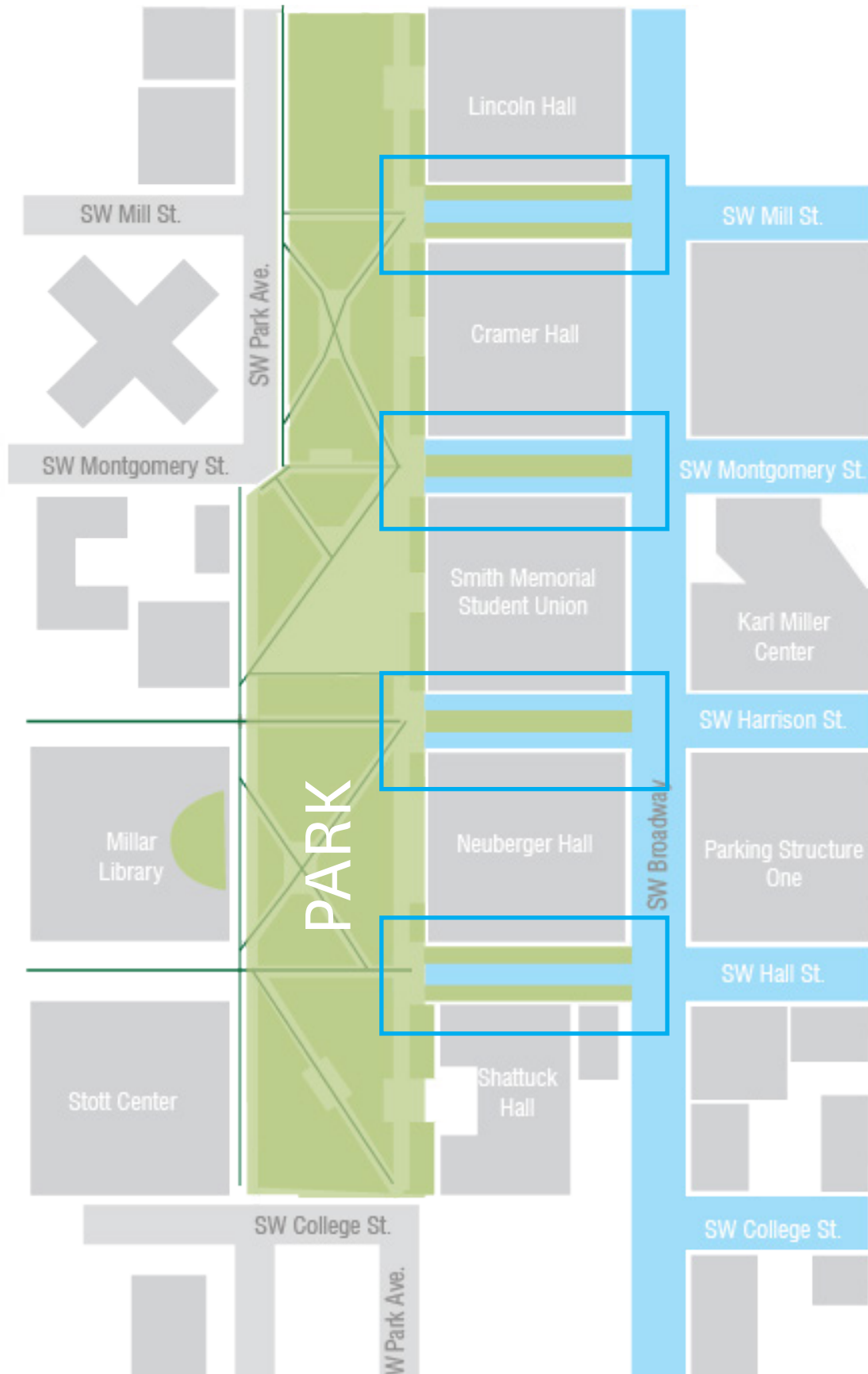

CITY

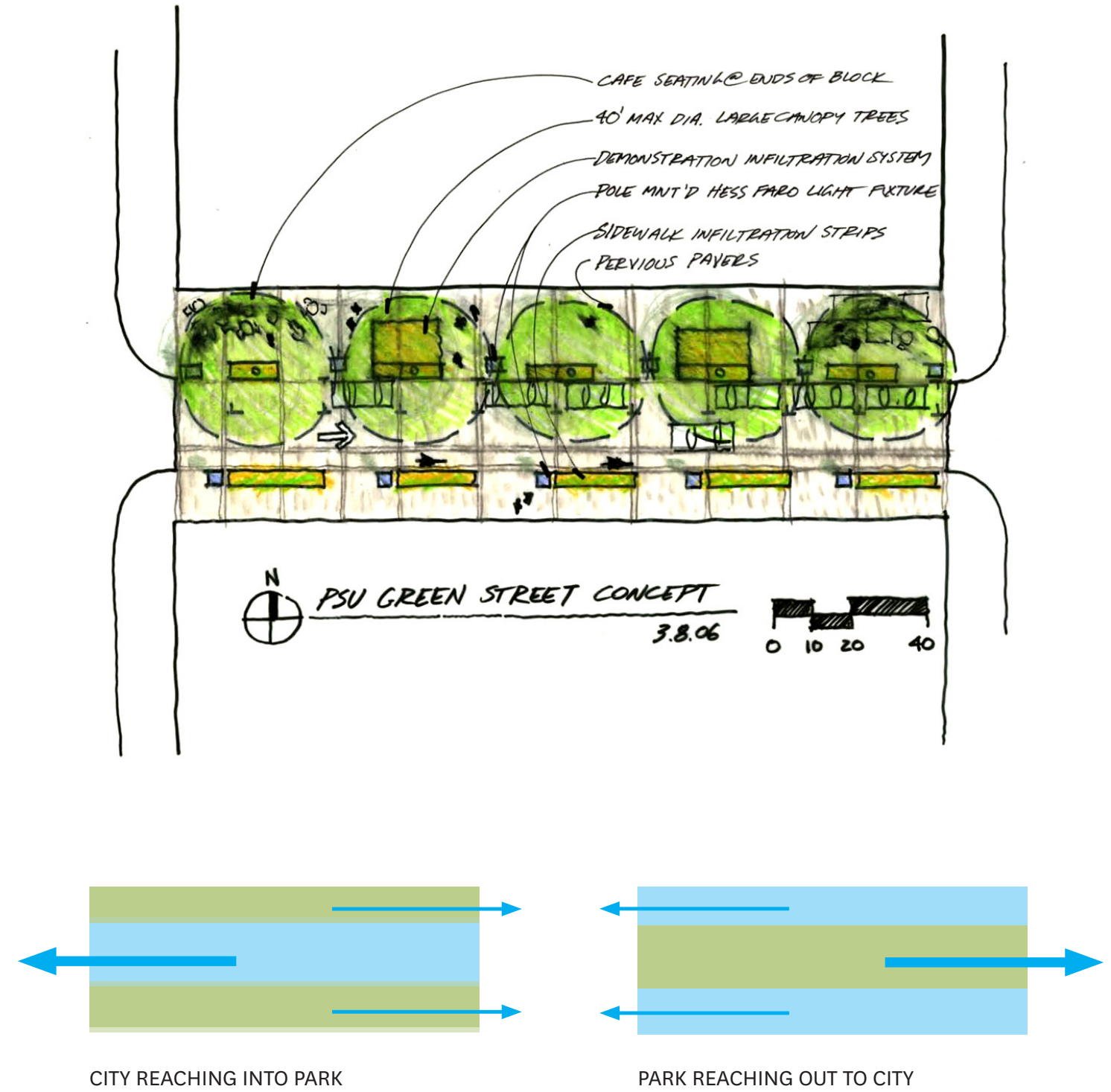

EAST AND WEST TRANSITIONS

HACKER



FROM BROADWAY



FROM PARK

EAST AND WEST TRANSITIONS

HACKER

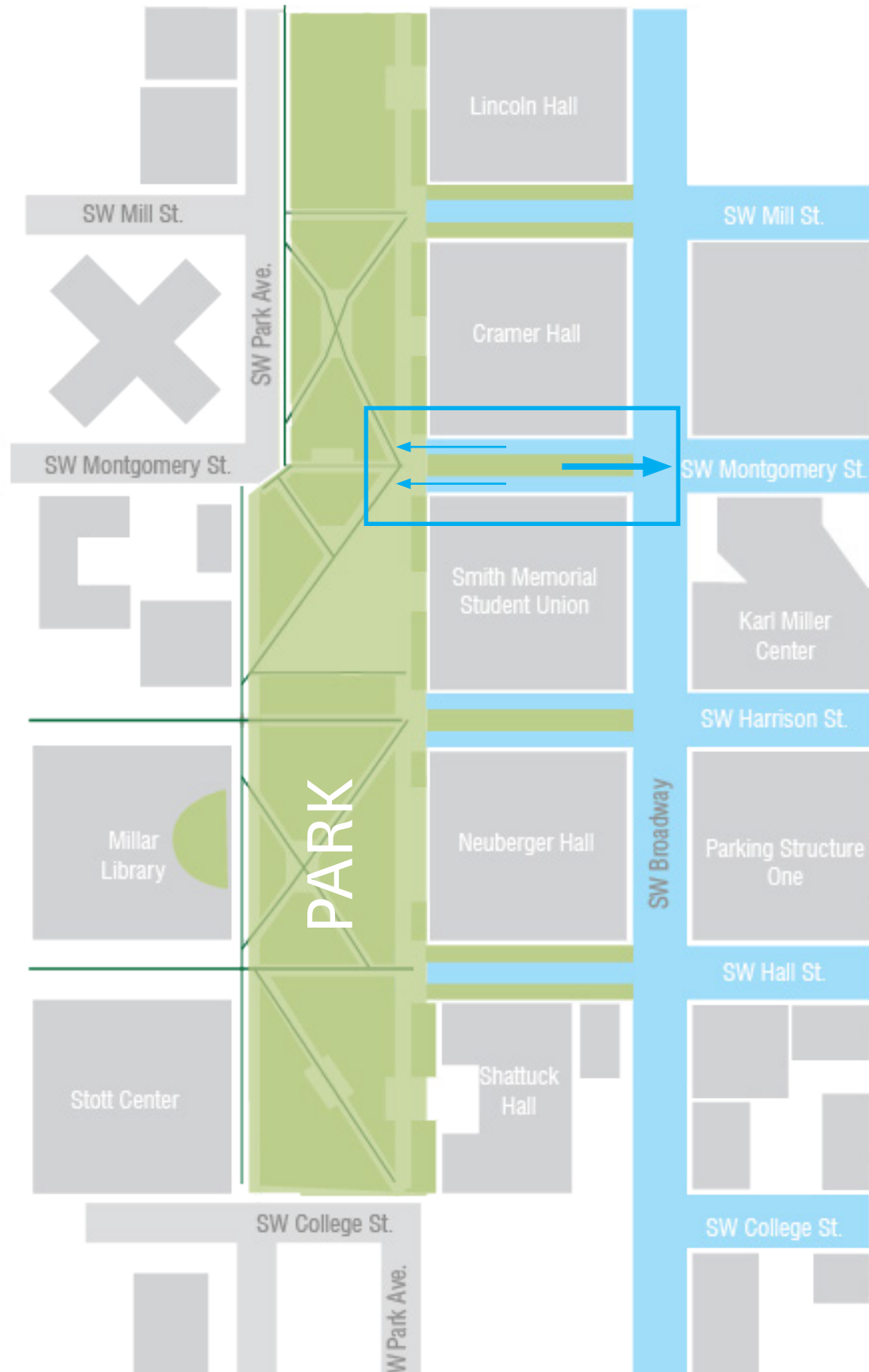

FROM BROADWAY



FROM PARK

CITY

EAST AND WEST TRANSITIONS

HACKER

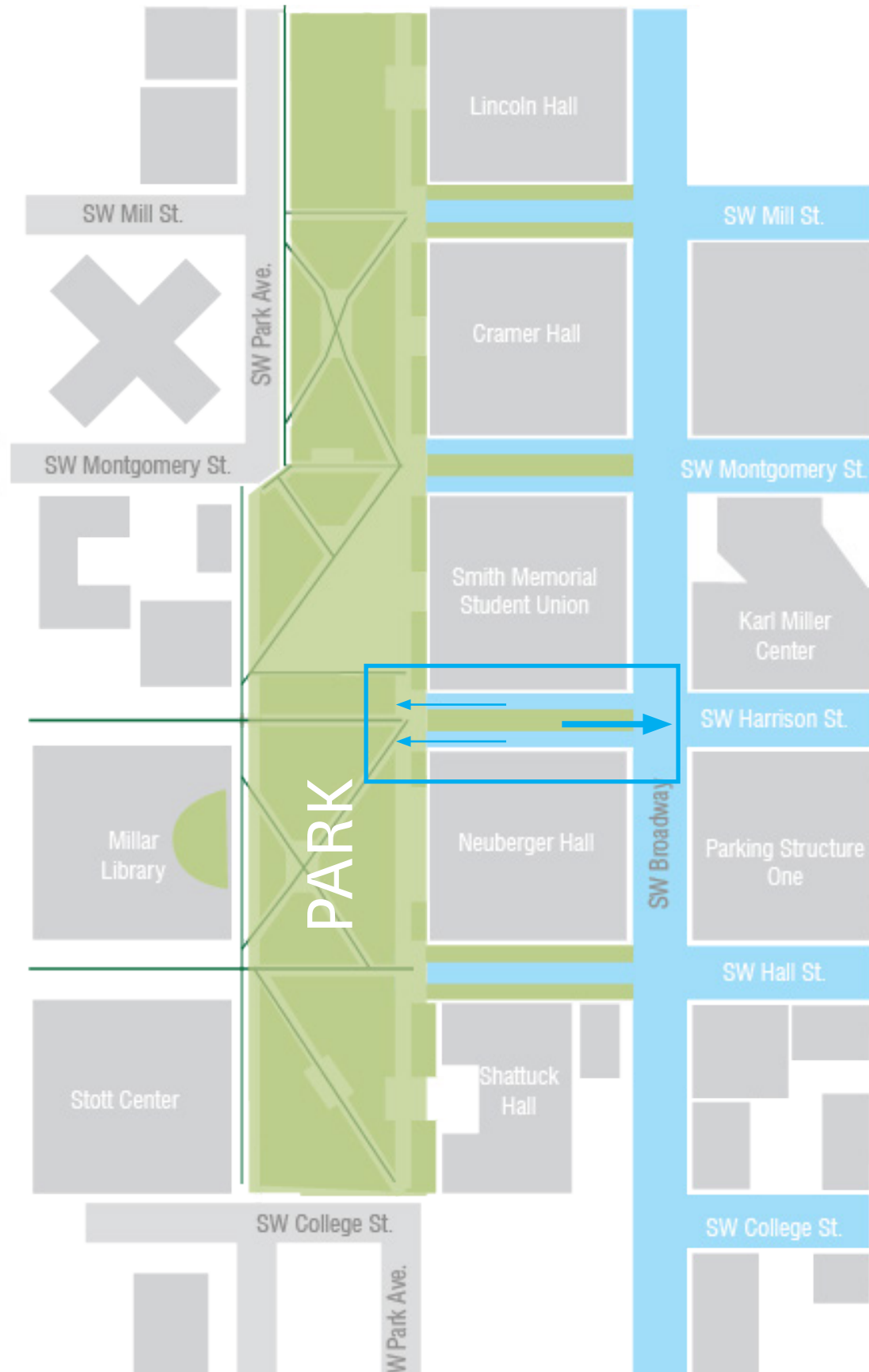

CITY



FROM BROADWAY



FROM PARK

EAST AND WEST TRANSITIONS

HACKER

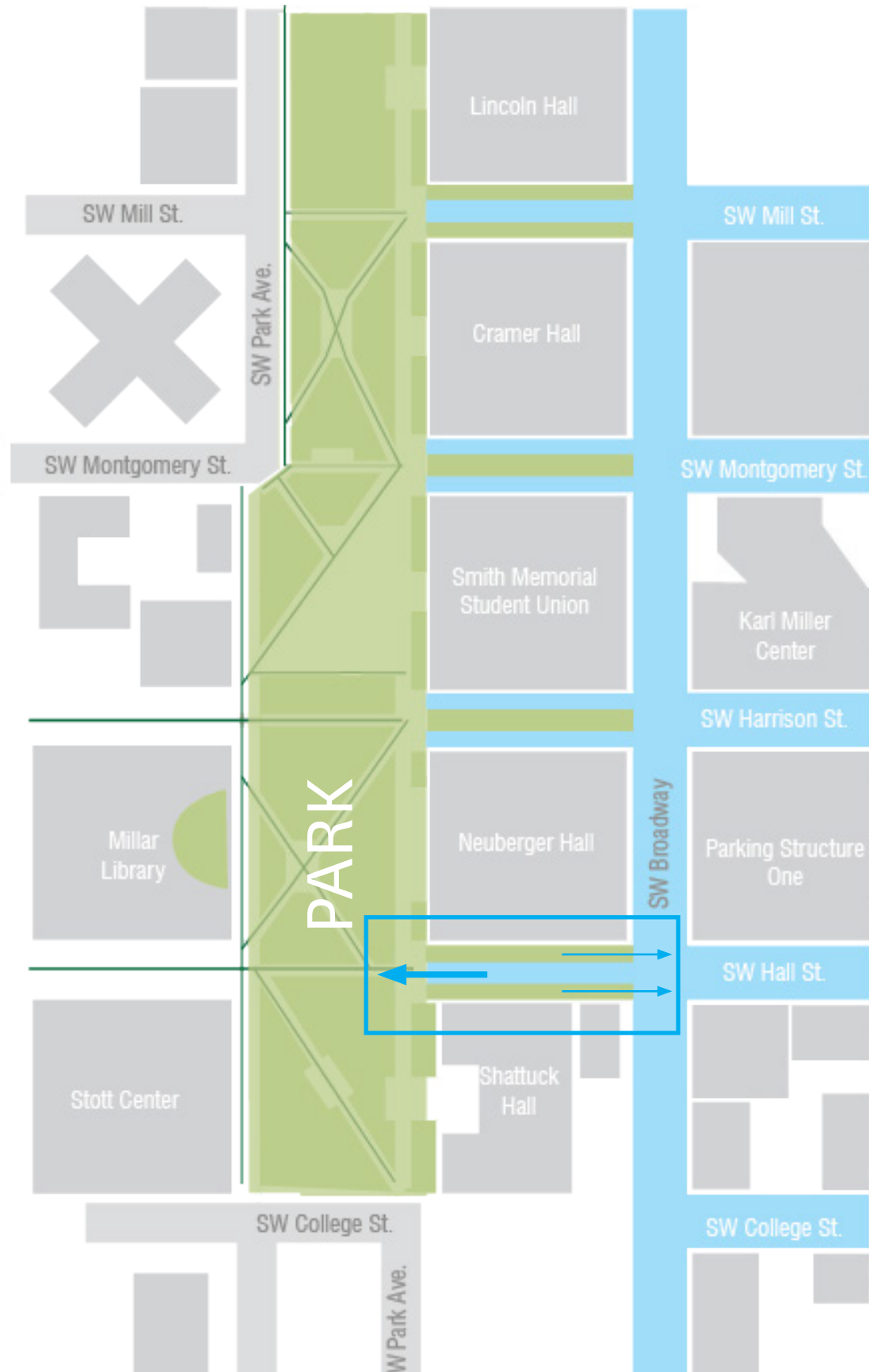

CITY



FROM BROADWAY



FROM PARK

EAST AND WEST TRANSITIONS

HACKER



LINCOLN HALL FROM BROADWAY



SHATTUCK HALL FROM PARK

PORCHES AND STOREFRONTS

HACKER

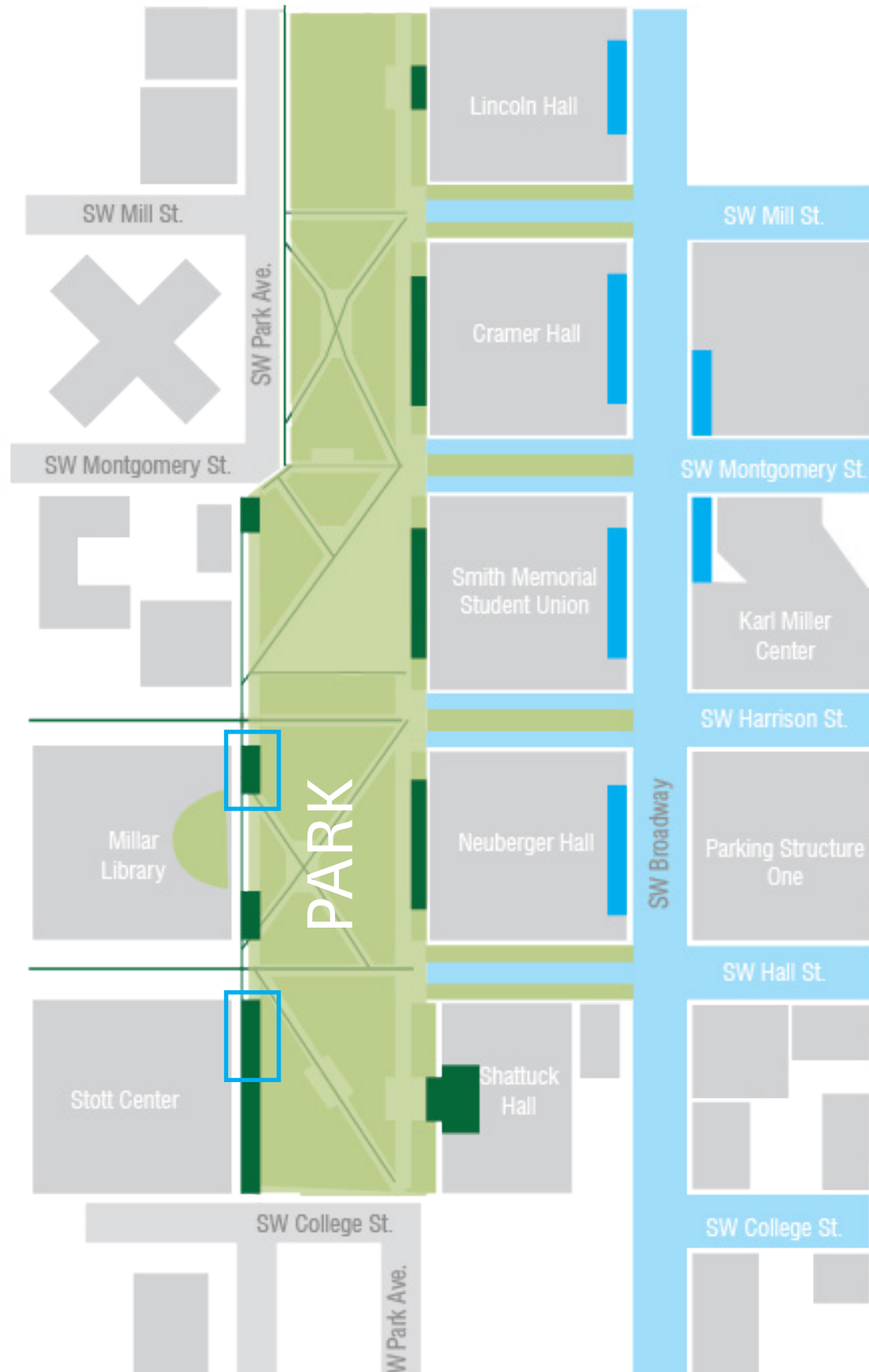

MILLAR LIBRARY FROM PARK



STOTT CENTER FROM PARK

PORCHES AND STOREFRONTS

HACKER



MILLAR LIBRARY FROM PARK



STOTT CENTER FROM PARK

PORCHES AND STOREFRONTS

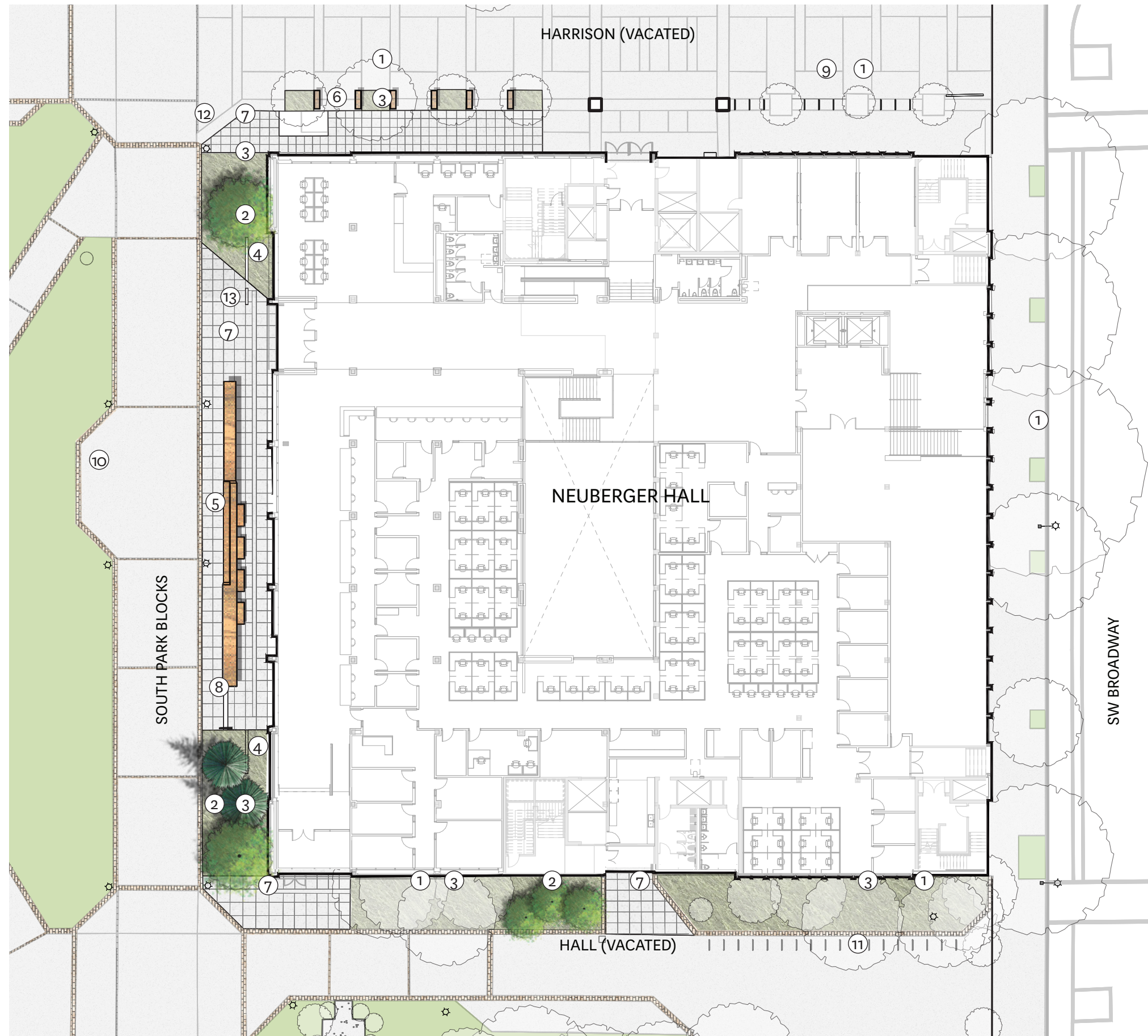

KEY

- ① Existing Trees to Remain
- ② Proposed Trees
- ③ Refurbished Planting Area
- ④ Vegetated Stormwater Area
- ⑤ "Social Jetty"
- ⑥ Bench
- ⑦ Scored Concrete Paving
- ⑧ Steps w/ Handrails
- ⑨ Relocated Bicycle Racks
- ⑩ Seating to remain
- ⑪ Bicycle Racks to Remain
- ⑫ Existing Lightpole to Remain
- ⑬ Museum Sign



SITE PLAN

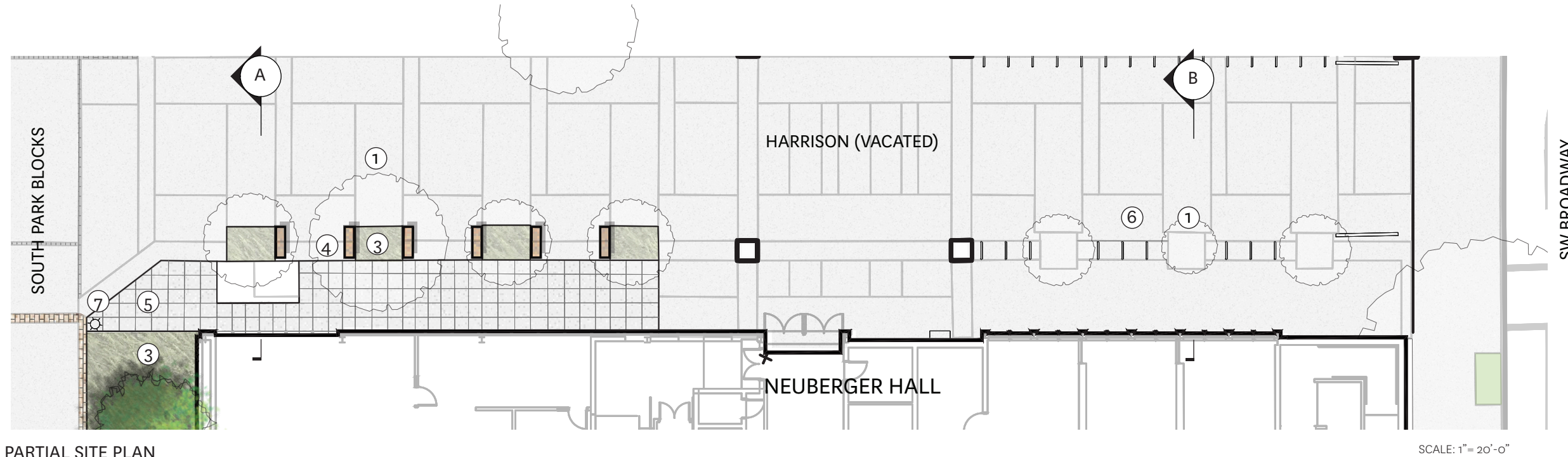

PARTIAL SITE PLAN

SCALE: 1" = 20'-0"

- KEY**
- ① Existing Trees to Remain
 - ② Proposed Trees
 - ③ Refurbished Planting Area
 - ④ Bench
 - ⑤ Scored Concrete Paving
 - ⑥ Relocated Bicycle Racks
 - ⑦ Existing Lightpole to Remain

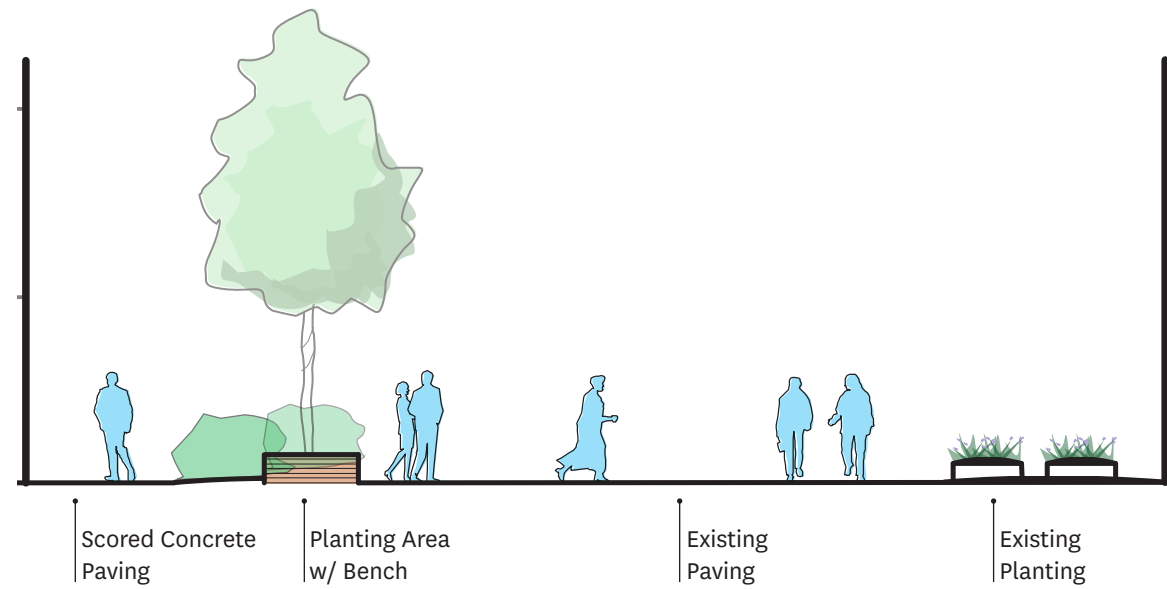

SECTION - A
SCALE: 1" = 10'-0"

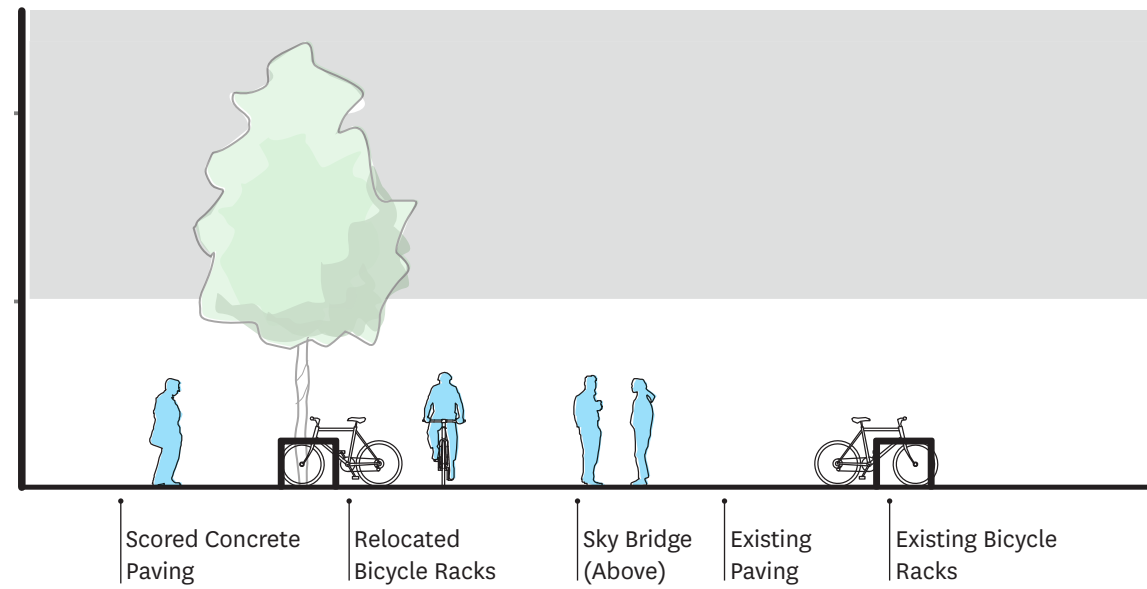

SECTION - B
SCALE: 1" = 10'-0"

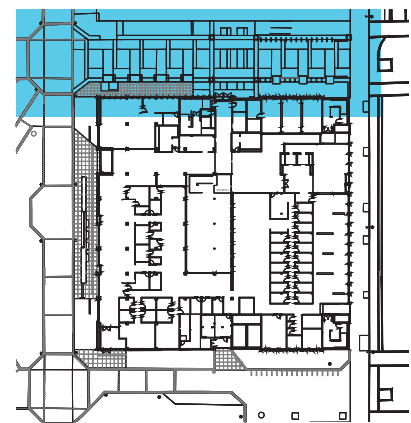

PARTIAL SITE PLAN - NORTH



ELEVATION - NORTH

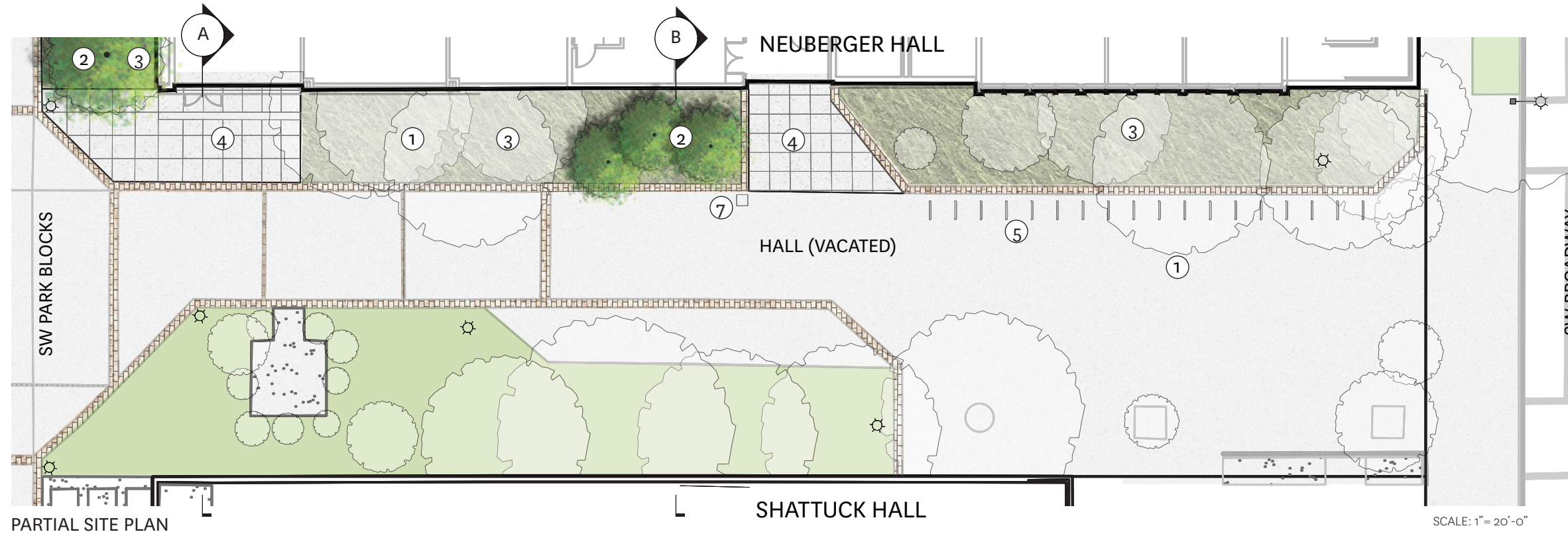

KEY

- ① Existing Trees to Remain
- ② Proposed Trees
- ③ Refurbished Planting Area
- ④ Scored Concrete Paving
- ⑤ Bicycle Racks to Remain
- ⑥ Existing Lightpole to Remain
- ⑦ Emergency Call Beacon

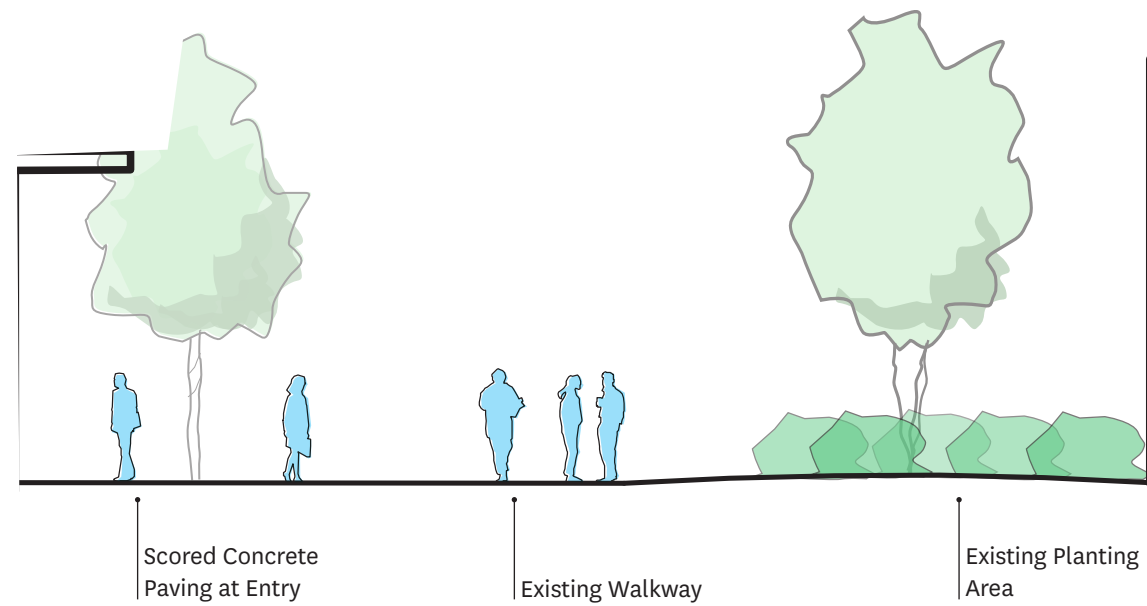

SECTION - A
SCALE: 1" = 10'-0"

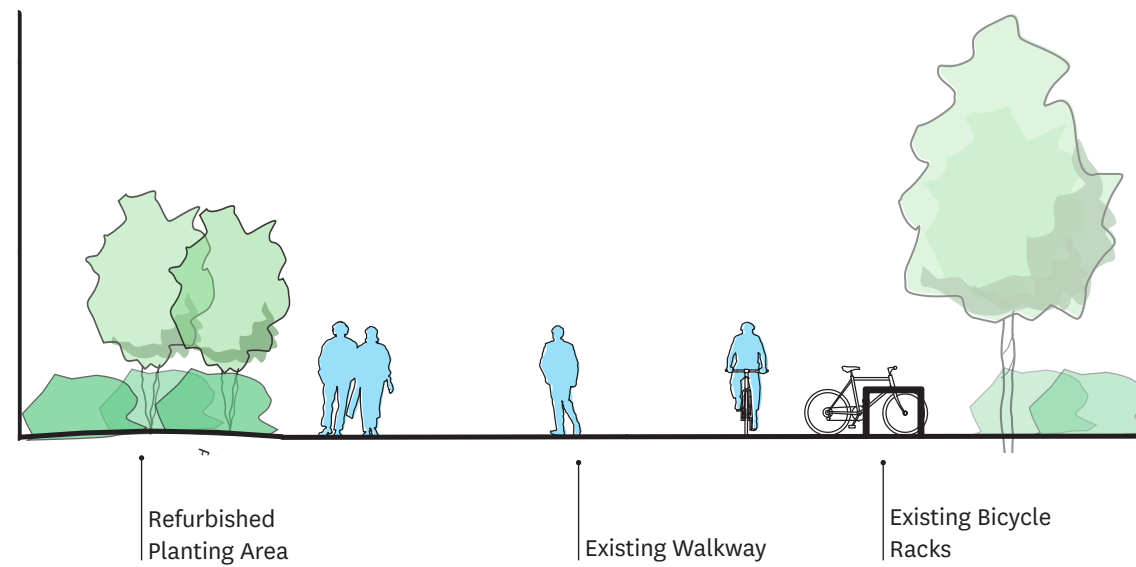

SECTION - B
SCALE: 1" = 10'-0"

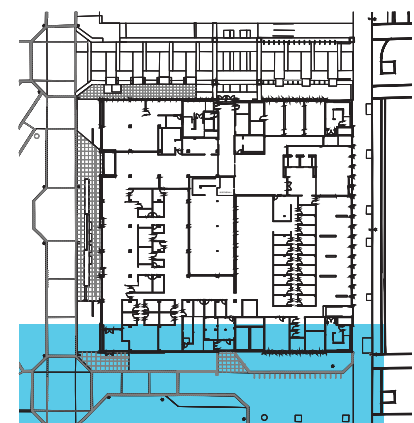

PARTIAL SITE PLAN - SOUTH



ELEVATION - SOUTH





PLACES TO PAUSE



PLACES TO PAUSE - SOCIAL JETTY



PLACES TO PAUSE - SOCIAL JETTY



PLACES TO PAUSE - SOCIAL JETTY



“Social Jetty”

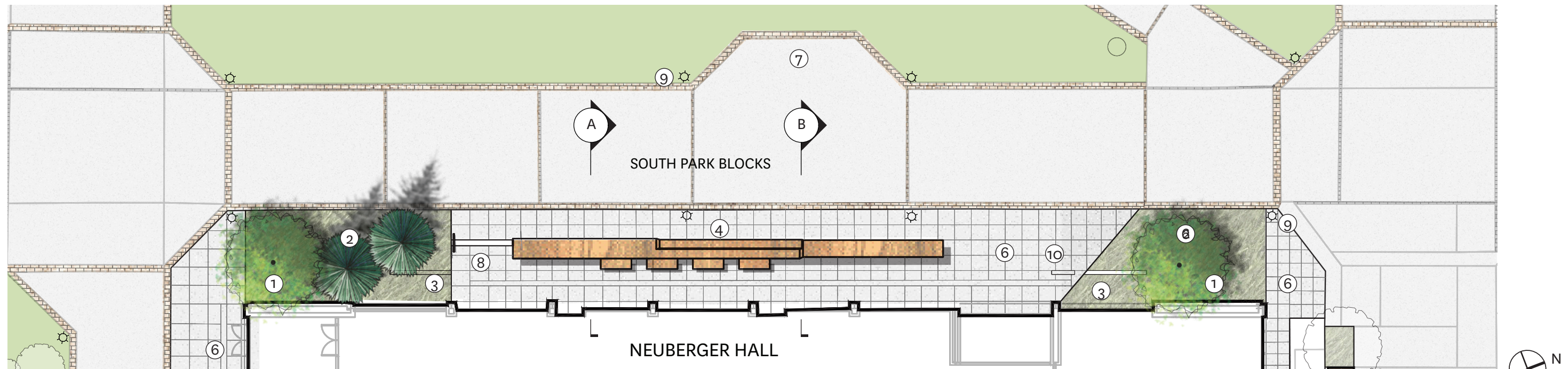

PARTIAL SITE PLAN OF WEST TERRACE

SCALE: 1" = 20'-0"

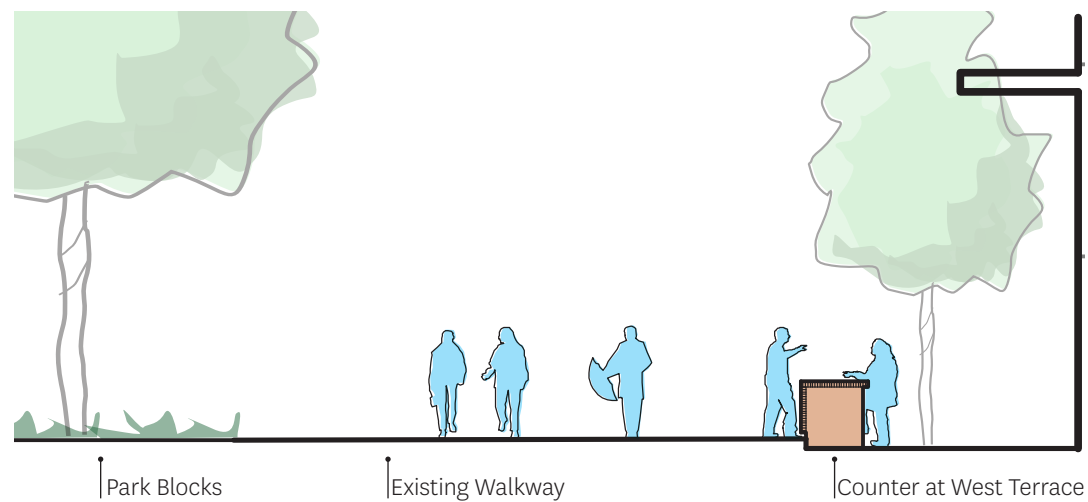

SECTION - A
SCALE: 1" = 10'-0"

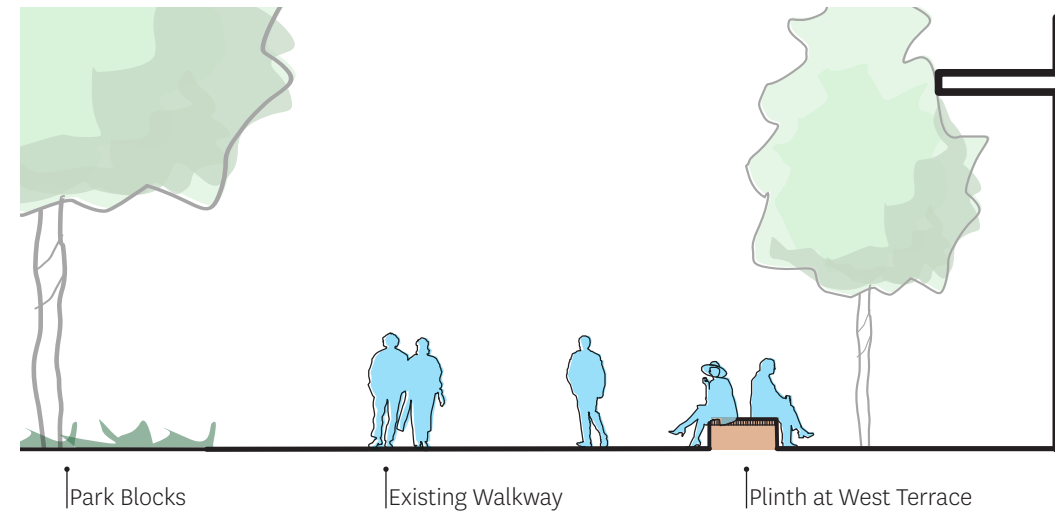

SECTION - B
SCALE: 1" = 10'-0"

KEY

- ① Proposed Trees
- ② Refurbished Planting Area
- ③ Vegetated Stormwater Area
- ④ “Social Jetty”
- ⑤ Bench
- ⑥ Scored Concrete Paving
- ⑦ Seating to Remain
- ⑧ Steps w/ Handrails
- ⑨ Existing Lightpole to Remain
- ⑩ Museum Sign

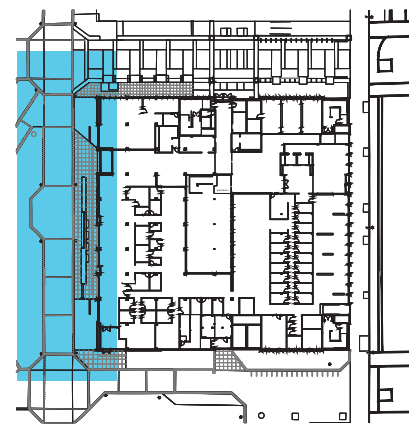

PARTIAL SITE PLAN - WEST

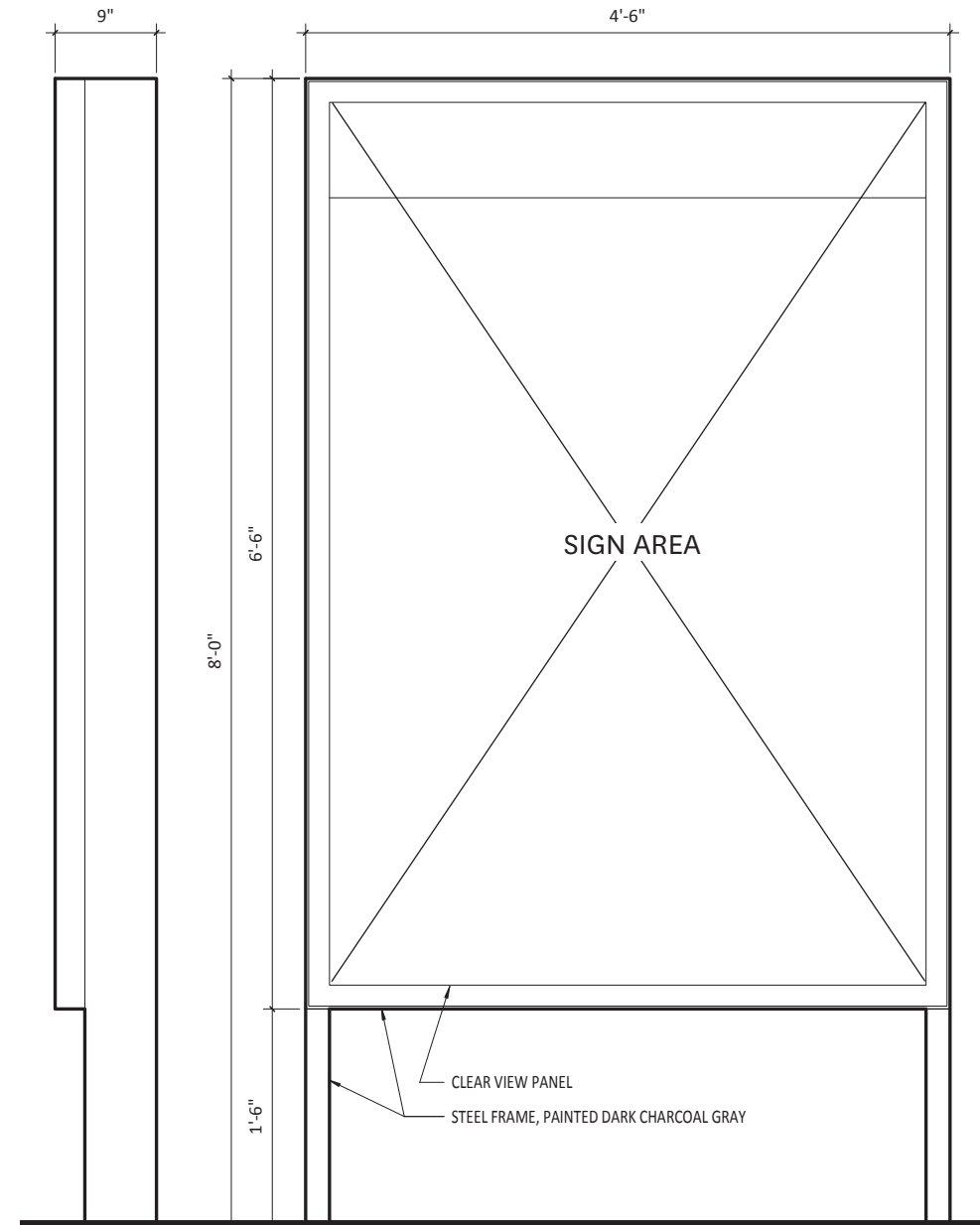
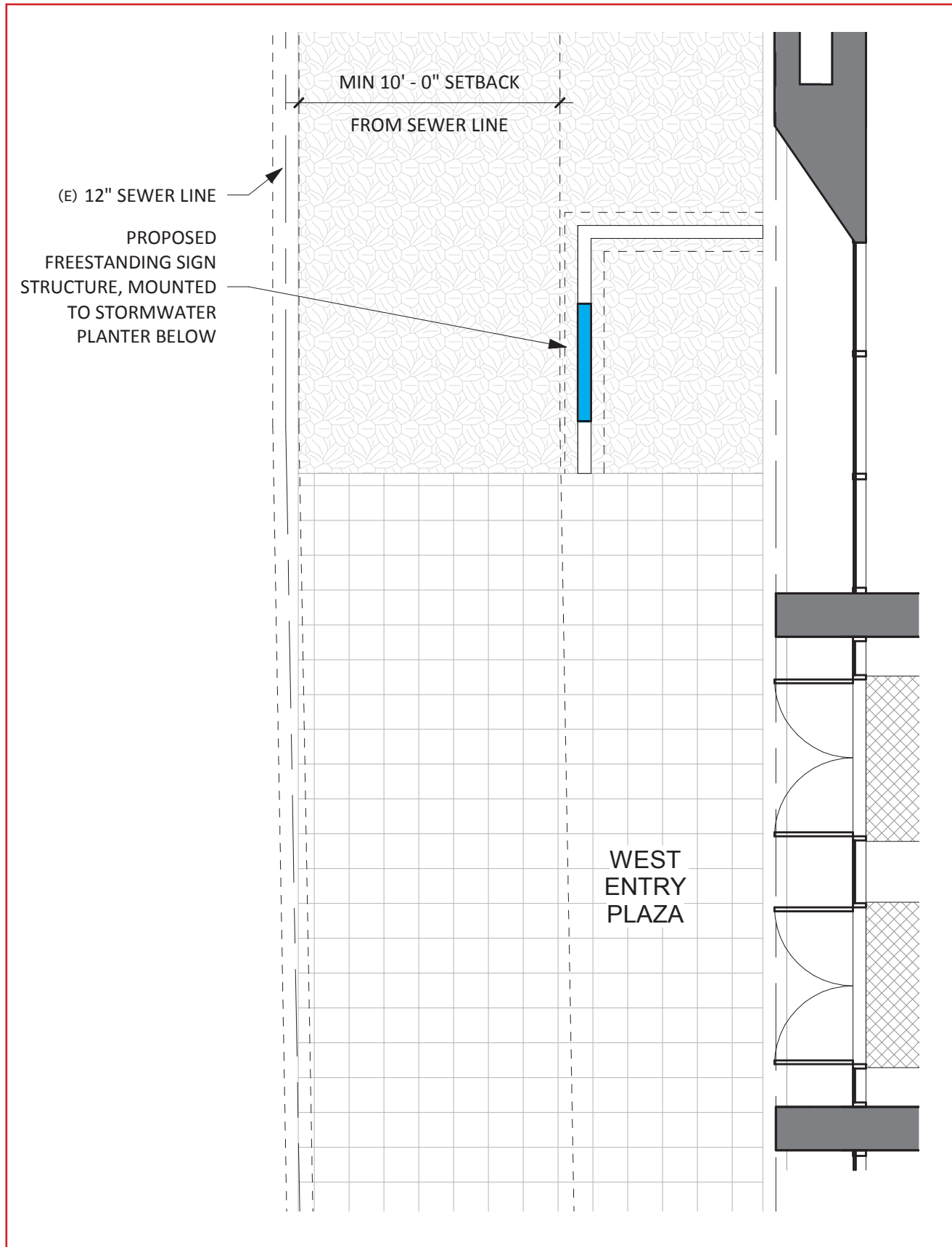

Side View

Front View

ELEVATION
3/4" = 1' - 0"

PLAN VIEW
3/4" = 1' - 0"

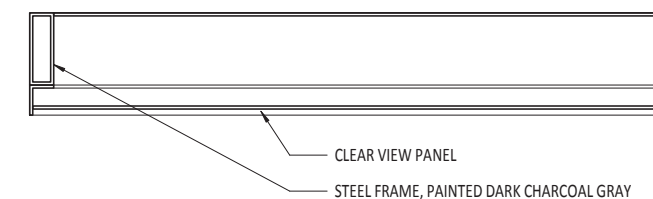

PRECEDENT 1 - Freestanding Sign



PRECEDENT 2 - Freestanding Sign

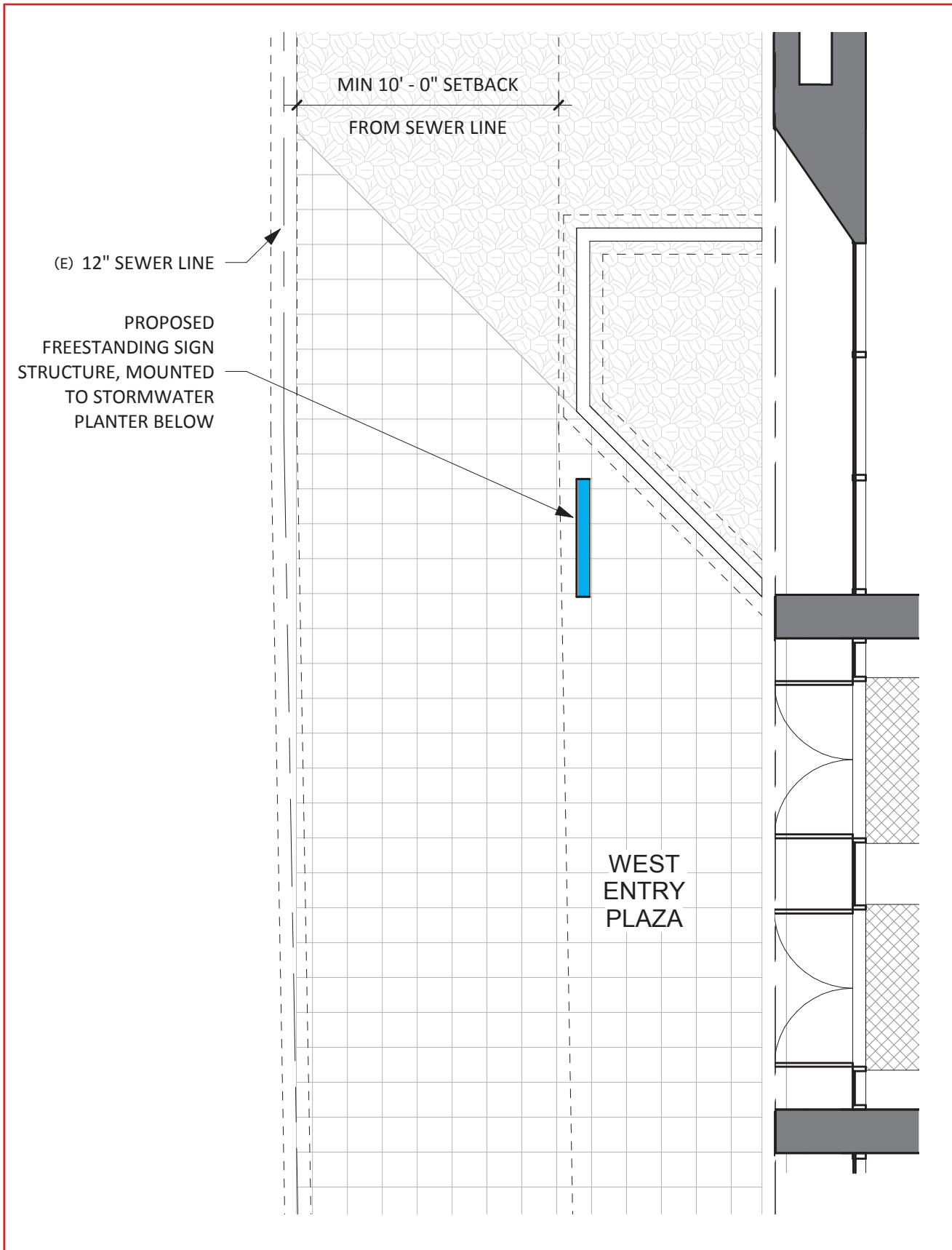

RENDERING: NEUBERGER HALL WEST ENTRY FROM PARK



HARRISON
(VACATED)

Refurbished
Planting Area

Refurbished
Planting Area

Vegetated
Stormwater Area

Building Entry

Seating Plinth

Counter

Vegetated
Stormwater Area

Refurbished
Planting Area

HALL
(VACATED)

ELEVATION - WEST

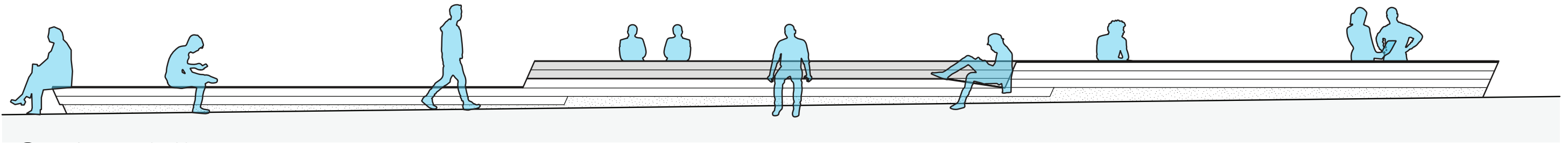

1 WEST ELEVATION COUNTER
SCALE: NTS

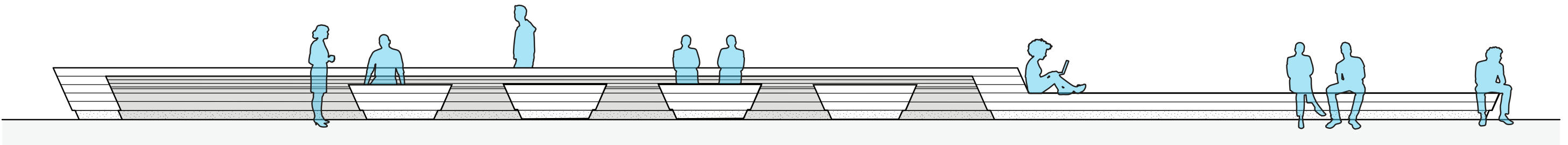

2 EAST ELEVATION COUNTER
SCALE: NTS

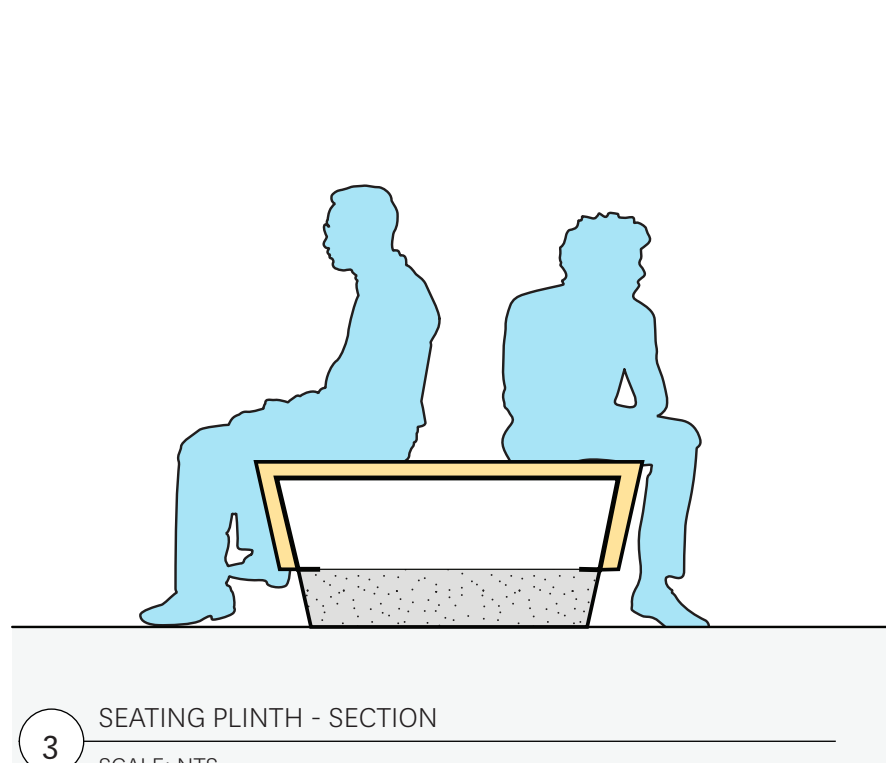

3 SEATING PLINTH - SECTION
SCALE: NTS

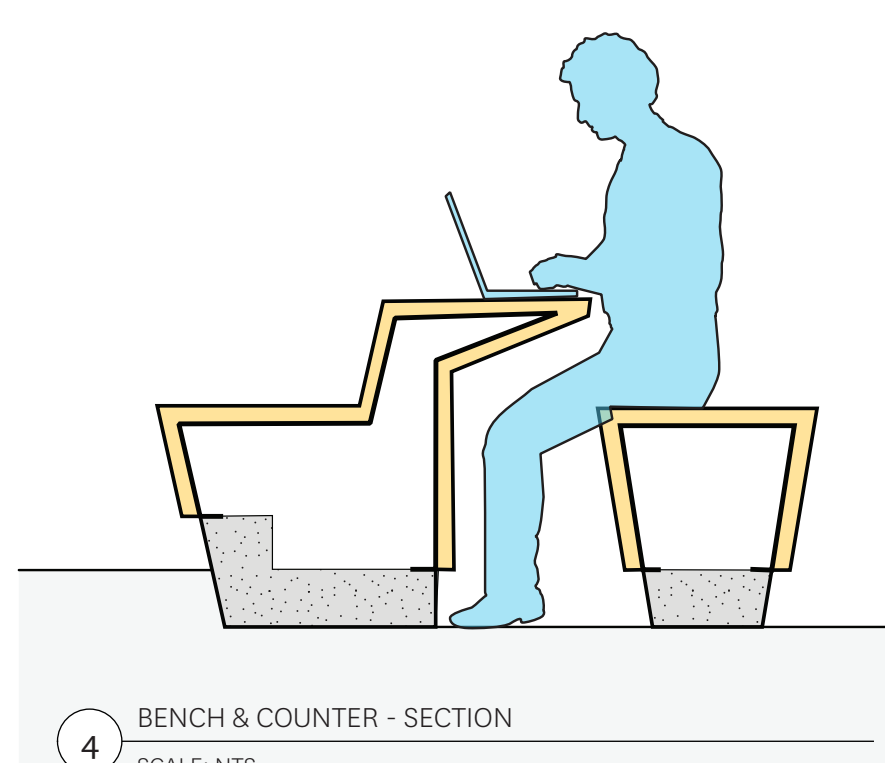

4 BENCH & COUNTER - SECTION
SCALE: NTS

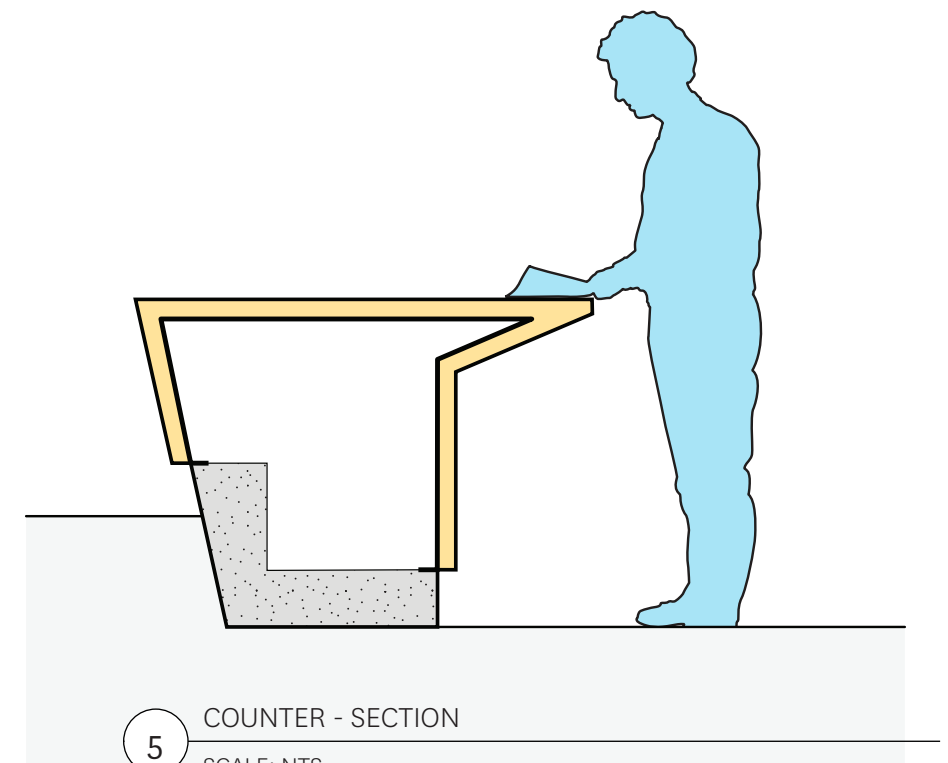

5 COUNTER - SECTION
SCALE: NTS

SITE FURNISHING DETAILS

GENERAL NOTES:
 1. ALL LUMBER IS 5/4X4 (1x3.5) IPE. CUT BOARDS LENGTHWISE TO ACHIEVE 1x1.75. SET WITH 1/4" GAPS UNLESS OTHERWISE NOTED. ATTACH TO STEEL FROM OUTSIDE FACE WITH XXX. COUNTERSINK AND FILL HOLES.
 2. ALL STEEL FRAMES ARE 3" X 1/2" STAINLESS STEEL UNLESS OTHERWISE NOTED. USE 3" X 1/2" ANCHOR TO ATTACH FRAMES TO GP CONCRETE BASE.

1 COUNTER DETAIL NOTES
 SCALE: NTS

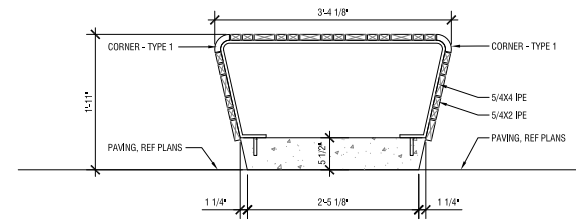

2 COUNTER - SECTION
 SCALE: 1/4\"/>

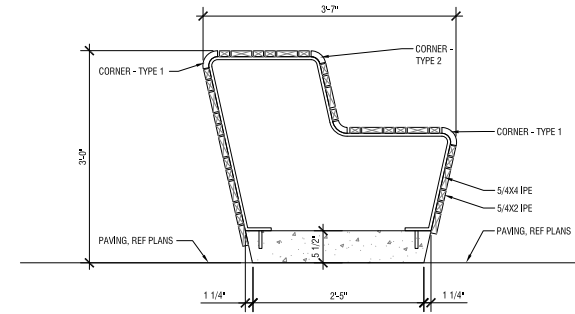

3 COUNTER - SECTION
 SCALE: 1/4\"/>

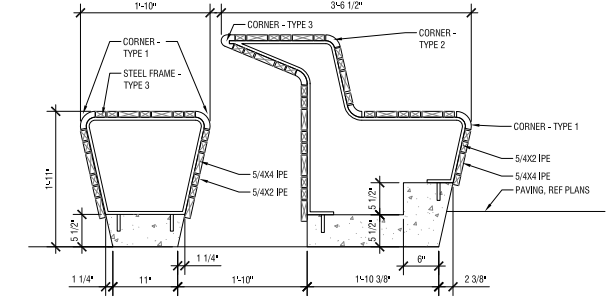

4 COUNTER - SECTION
 SCALE: 1/4\"/>

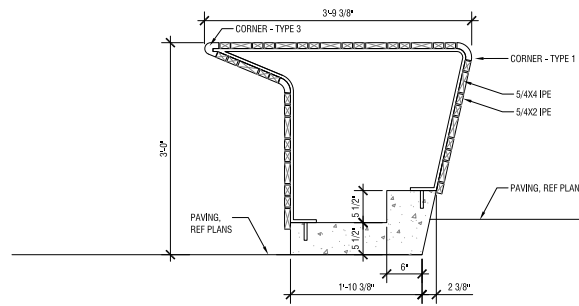

5 COUNTER - SECTION
 SCALE: 1/4\"/>

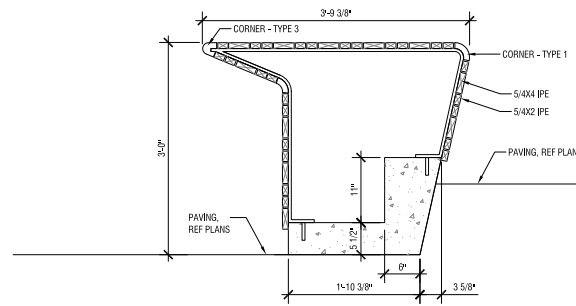

6 COUNTER - SECTION
 SCALE: 1/4\"/>

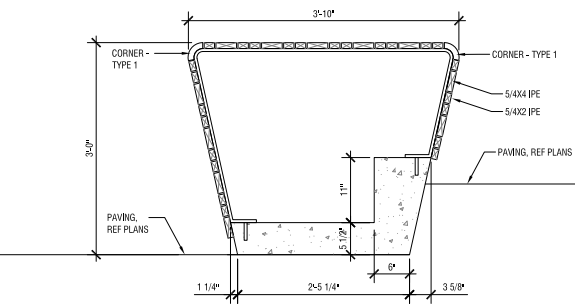

7 COUNTER - SECTION
 SCALE: 1/4\"/>

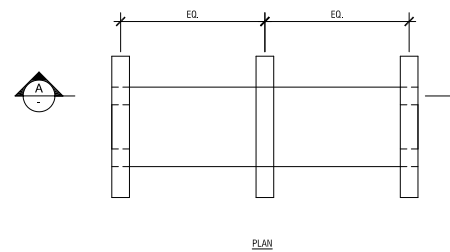

8 COUNTER SEAT - SECTION
 SCALE: 3/4\"/>

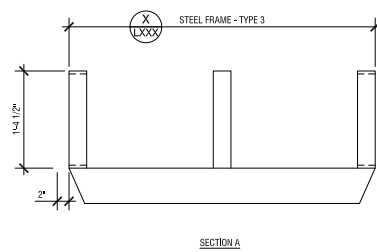

9 SKATE DETERRENT DETAIL
 SCALE: 1/4\"/>



EXISTING EAST FACADE

BROADWAY - EXISTING CONDITION



PROPOSED EAST FACADE



VIEW FROM SW PARK

PARK - NEUBERGER HALL (1961)



SOUTH PARK BLOCKS



SOUTH PARK BLOCKS



SOUTH PARK BLOCKS



FACADE CONCEPT - EXISTING FRAMEWORK





PROPOSED WEST FACADE | SW PARK



PROPOSED WEST FACADE | SW PARK

GROUND FLOOR MATERIALS



PROPOSED WEST FACADE | SW PARK

WEST FACADE - PROPOSED



PROPOSED WEST FACADE | SW PARK

EXISTING STRUCTURE

WEST FACADE - PROPOSED



PROPOSED WEST FACADE | SW PARK

WEST FACADE - PROPOSED



PROPOSED WEST FACADE | SW PARK

WEST FACADE - PROPOSED



PROPOSED WEST FACADE | SW PARK

EXISTING MULLIONS

WEST FACADE - PROPOSED



PROPOSED WEST FACADE | SW PARK

WEST FACADE - PROPOSED



PROPOSED WEST FACADE | SW PARK

WEST FACADE - PROPOSED



PROPOSED WEST FACADE | SW PARK

SLAB EDGE

WEST FACADE - PROPOSED



PROPOSED WEST FACADE | SW PARK

WEST FACADE - PROPOSED



PROPOSED WEST FACADE | SW PARK

FRAME

WEST FACADE - PROPOSED



PROPOSED WEST FACADE | SW PARK

WEST FACADE - PROPOSED



PROPOSED WEST FACADE

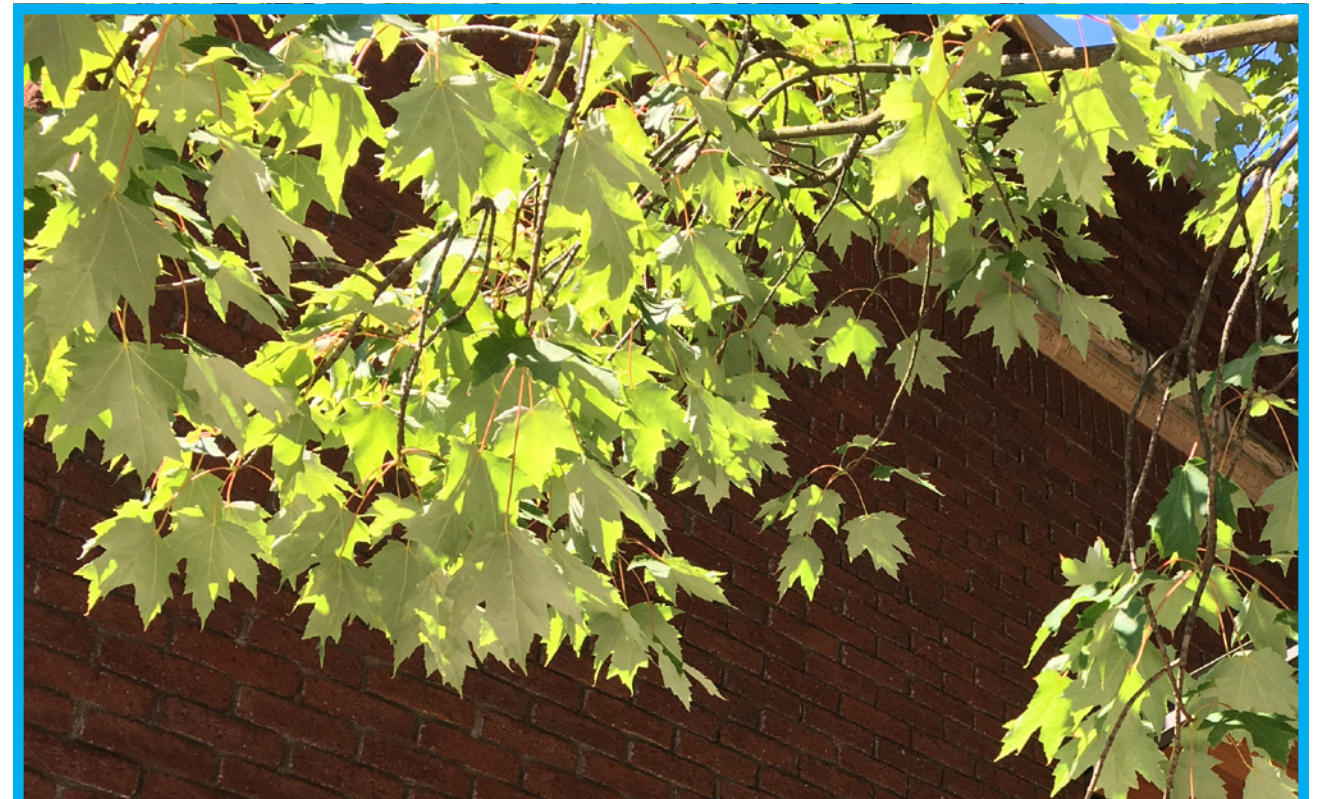

FOLIAGE OVER BUILDING

WEST ELEVATION STRATEGY - METAL



PROPOSED WEST FACADE

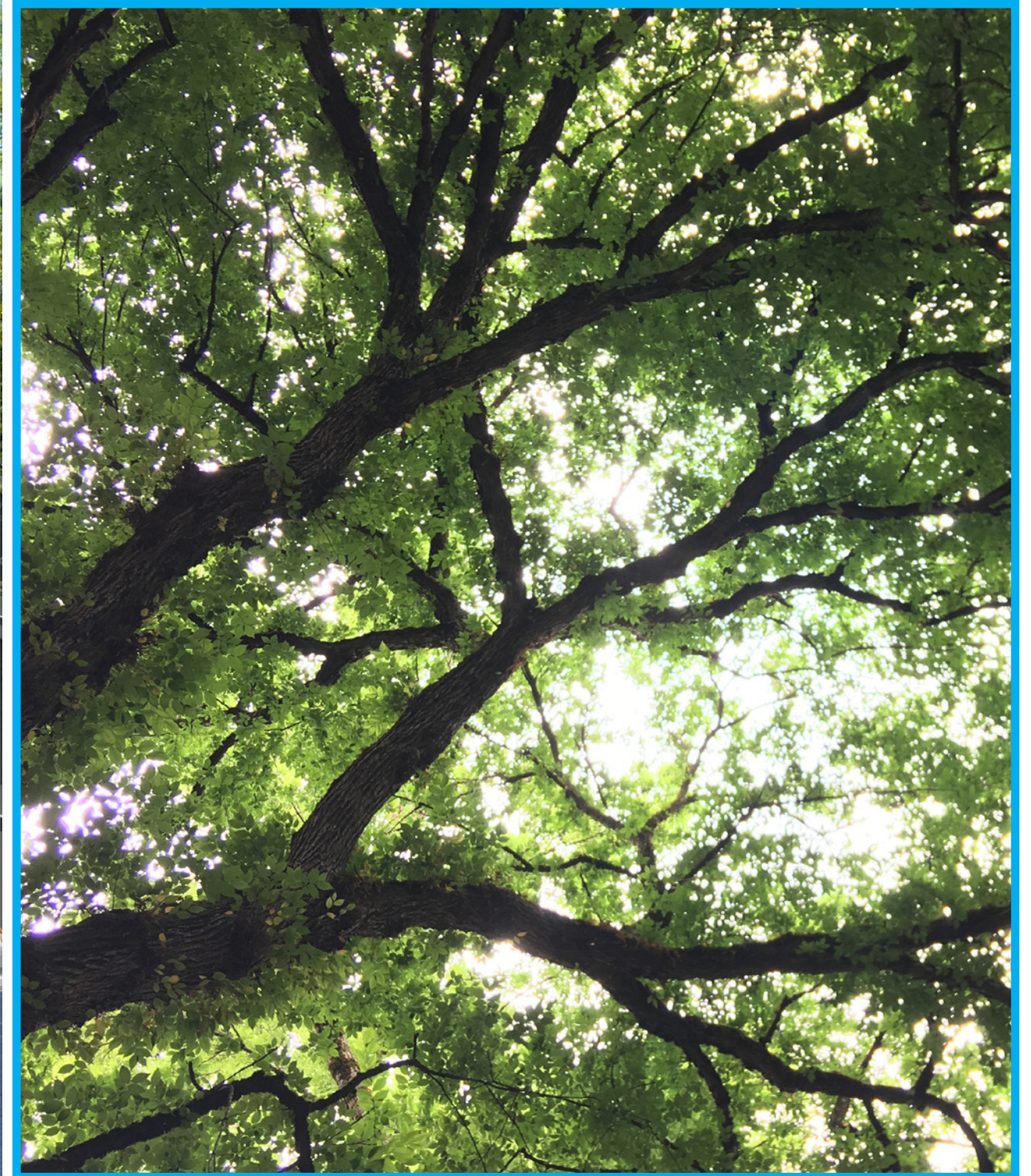

FOLIAGE BEHIND SKY

WEST ELEVATION STRATEGY - METAL

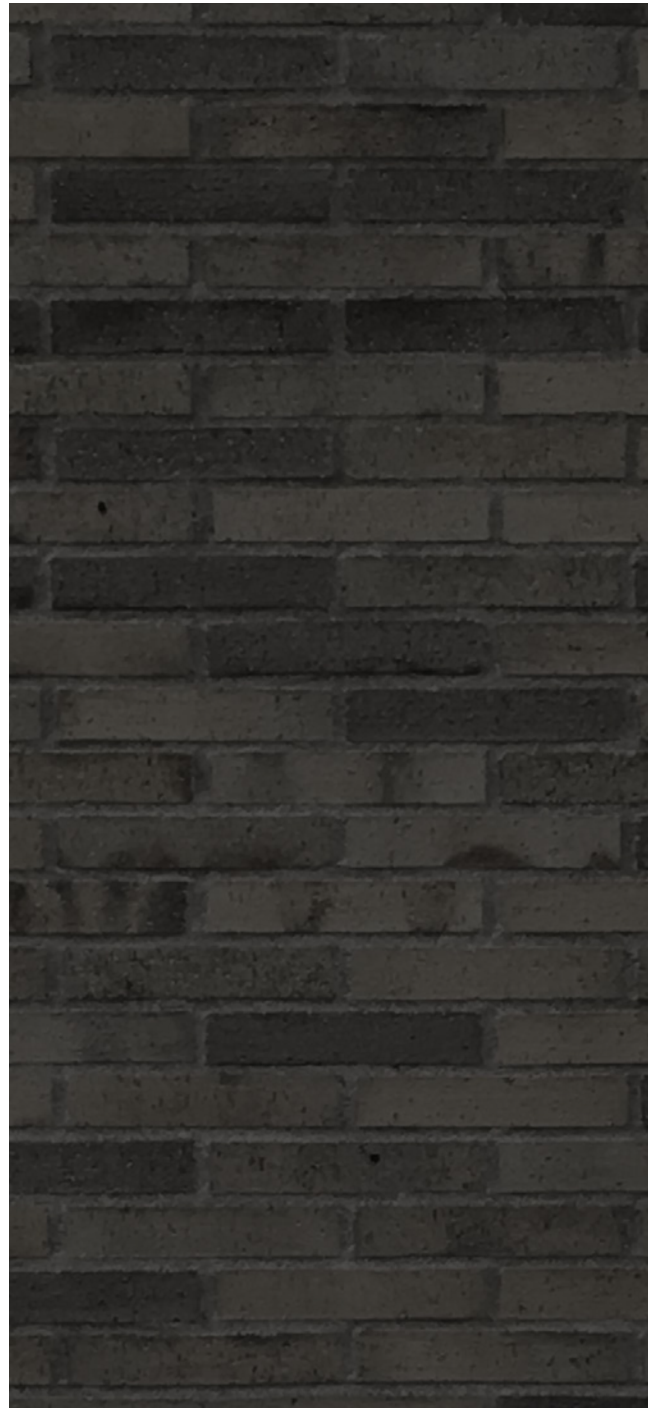

BRICK MASONRY

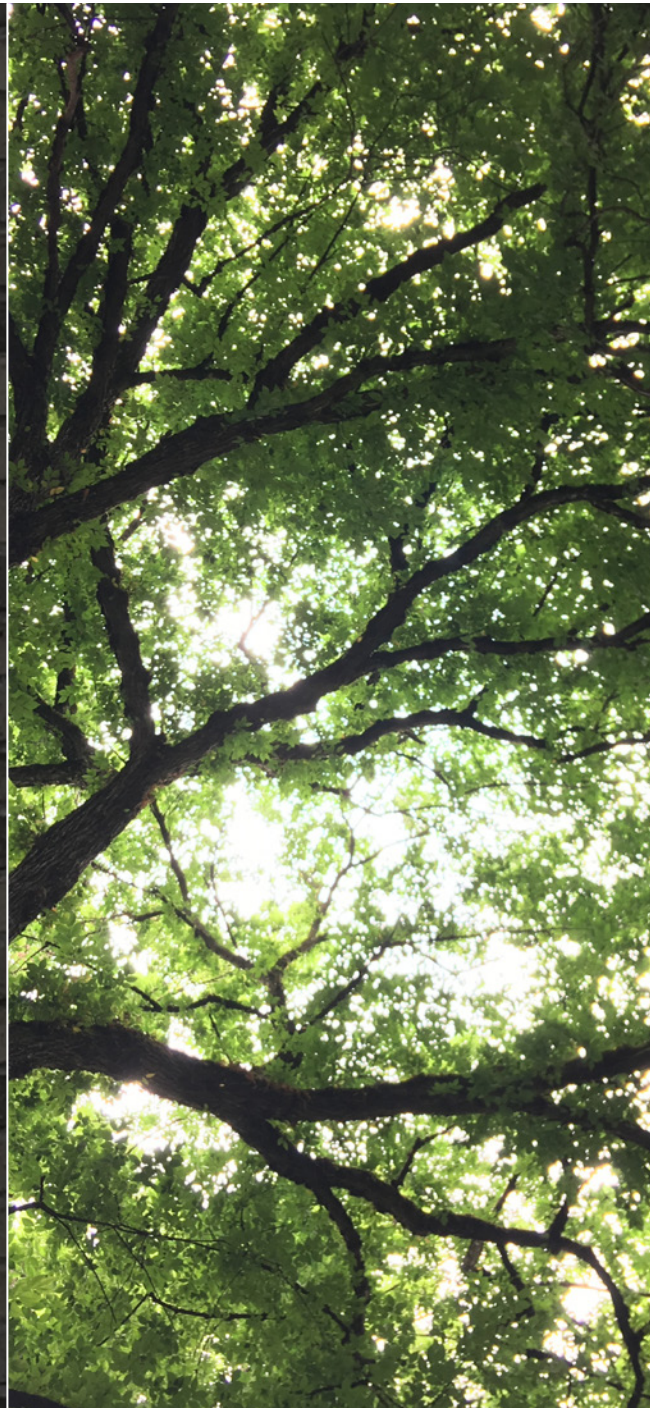

PARK FOLIAGE



COMPOSITE
METAL PANEL
(DARK GRAY)



GLASS WINDOW SYSTEM



WOOD
SOFFIT



COMPOSITE METAL PANEL
(METALLIC SILVER)

MATERIALS - STRATEGIES FOR DURABILITY





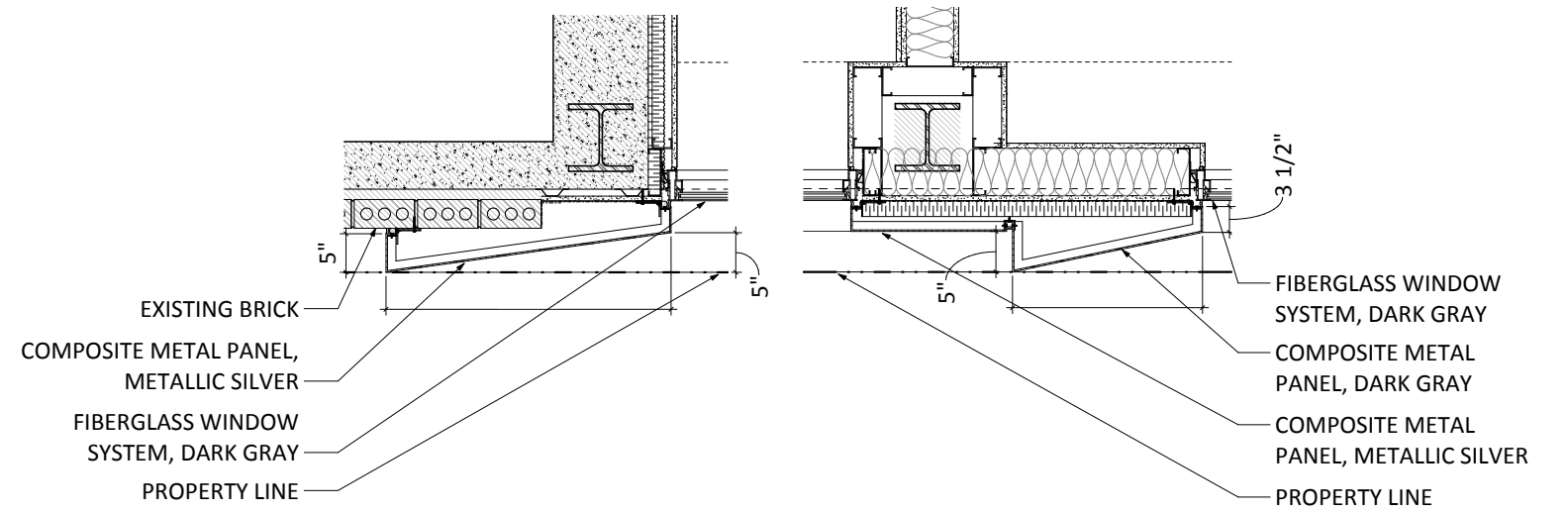

01-02

PLAN DETAIL at Metal Panel
NO SCALE

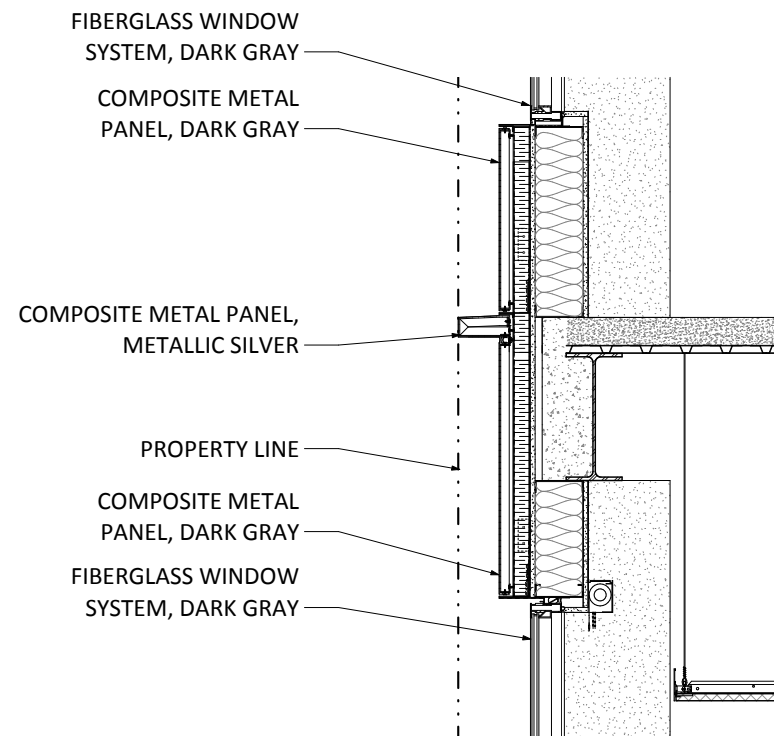

03 PLAN DETAIL at Metal Panel
NO SCALE



Exterior Cladding System | SW Park

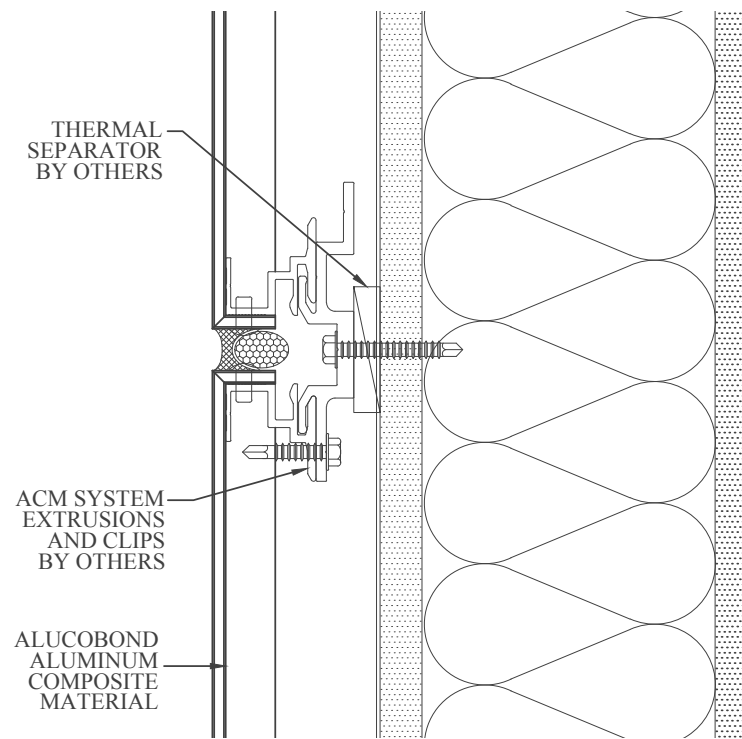

HORIZONTAL JOINT DETAIL



MATERIAL SAMPLE: COMPOSITE METAL PANEL



PRECEDENT: COMPOSITE METAL PANEL

MATERIAL CLADDING DETAILS

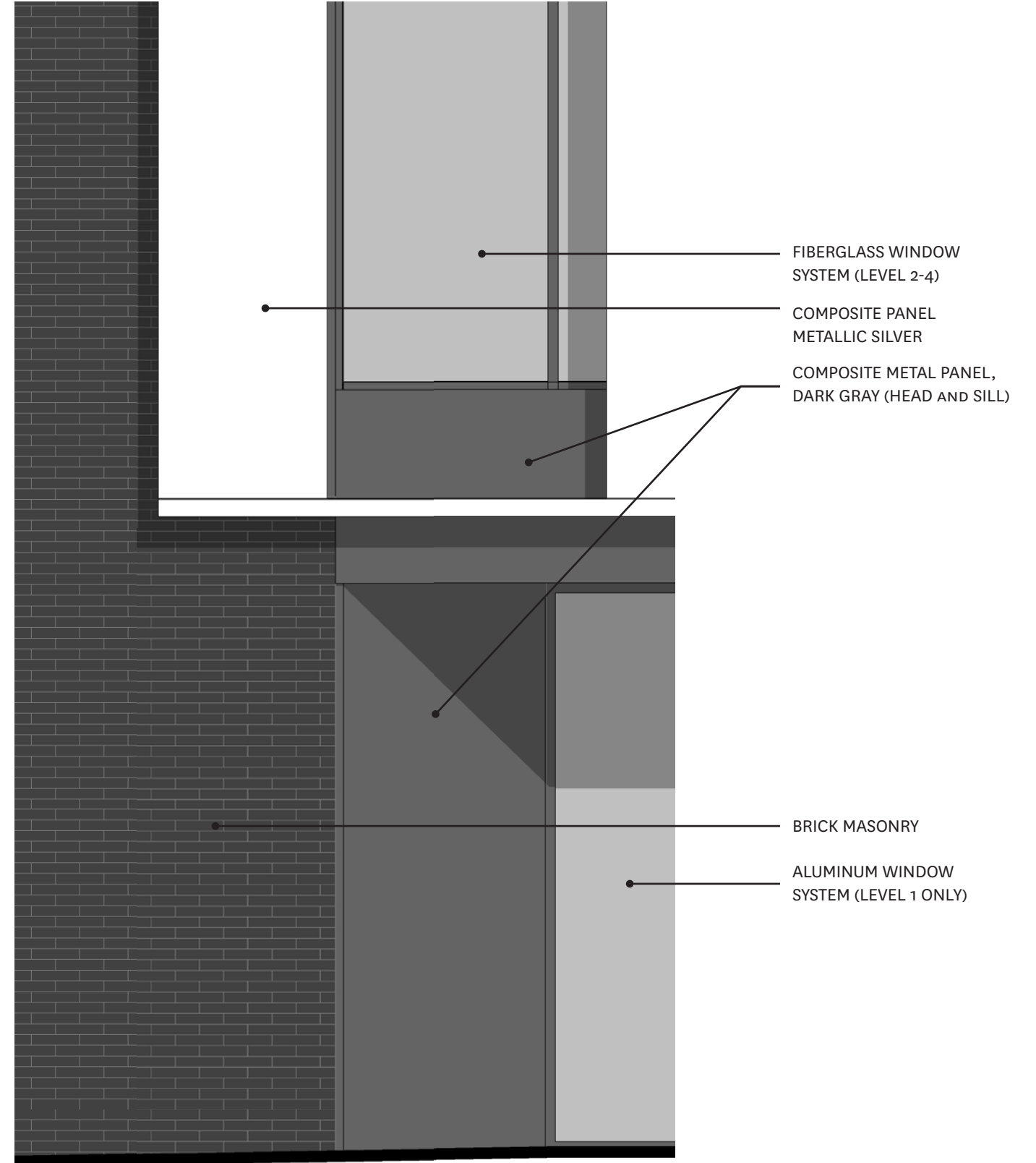

BRICK MASONRY AT GROUND LEVEL



PROPOSED NORTH FACADE | SW HARRISON

NORTH ELEVATION - PROPOSED



HARRISON - NEUBERGER HALL (1961)



HARRISON - NEUBERGER HALL (1961)



PROPOSED SOUTH FACADE | SW HALL

SOUTH ELEVATION - PROPOSED



PARK ENTRIES



PUBLIC ART - SW PARK



SCULPTURE CURRENT LOCATION



SCULPTURE DETAIL

PUBLIC ART - TOM HARDY SCULPTURE

END



FACADE MATERIAL - PROPOSED



FACADE MATERIAL - WITH BRICK LIME WASH



PROPOSED WEST FACADE | SW PARK

FACADE MATERIAL - PROPOSED



PROPOSED WEST FACADE | SW PARK

FACADE MATERIAL - WITH BRICK LIME WASH



HARRISON - NEUBERGER HALL (1961)

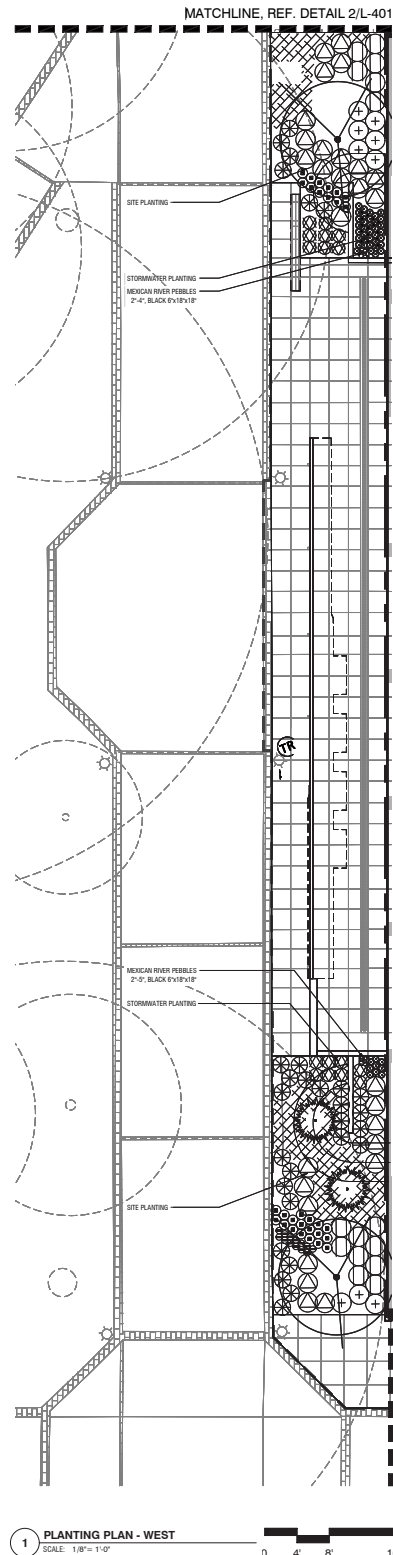

1 PLANTING PLAN - WEST
SCALE: 1/8" = 1'-0"

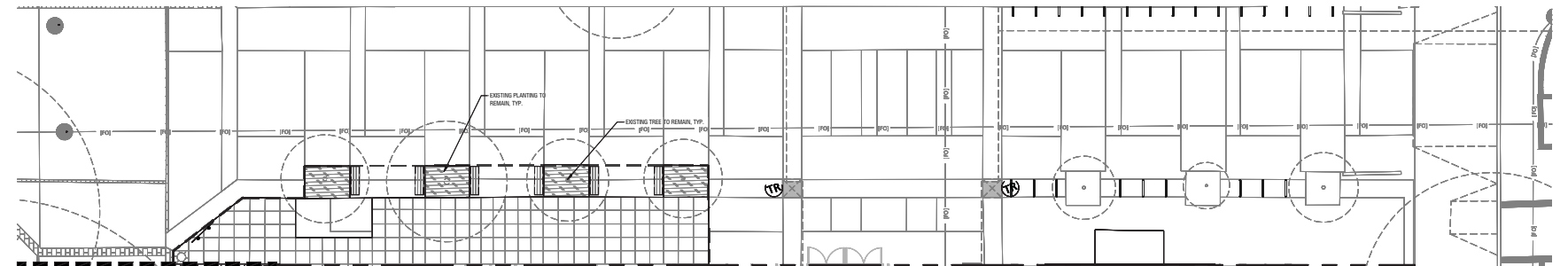

2 PLANTING PLAN - NORTH
SCALE: 1/8" = 1'-0"

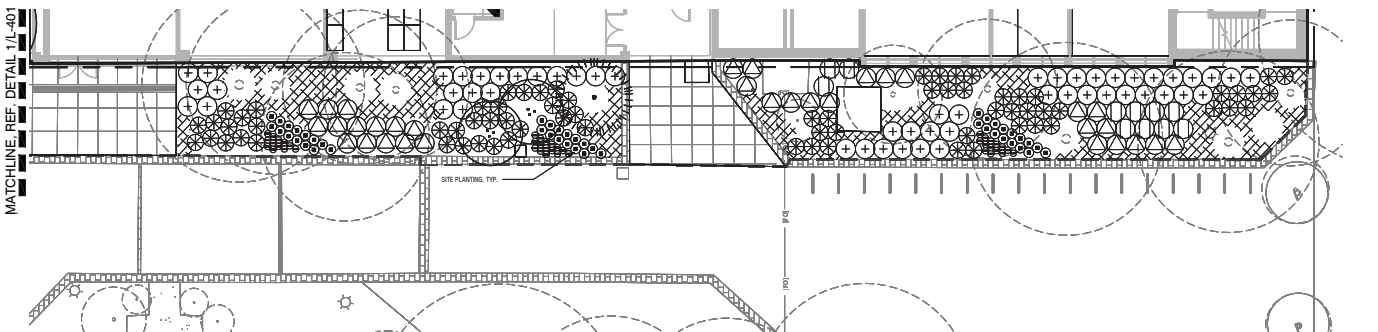

3 PLANTING PLAN - SOUTH
SCALE: 1/8" = 1'-0"

SITE PLANTING

SYMBOL	LATIN NAME	COMMON NAME	CONT./SIZE	SPACING	NOTES
TREES					
	ACER CIRCINATUM	VINE MAPLE	2.5" CAL / B&B	AS SHOWN	
	CERCODIPHYLLUM JAPONICUM ROTIFOLIUS	RED FOX KATSURA	2.5" CAL / B&B	AS SHOWN	
	THUJA PLICATA HOGAN	HOGAN'S RED CEDAR	10" - 12" HT. / B&B	AS SHOWN	
	TSUGA MERTENSIANA	MOUNTAIN HEMLOCK	8" - 10" HT. / B&B	AS SHOWN	
SHRUBS					
	IRIS TENAX	OREGON IRIS	#1 CONT.	12" O.C.	
	MAHONIA EURHYMENOCARPA	SOFT CARESS MAHONIA	#5 CONT.	30" O.C.	
	POLYGONATUM ODORATUM VARIEGATUM	SOLOMON'S SEAL	#1 CONT.	18" O.C.	
	POLYSTICHUM MUNIFOLIUM	WESTERN SWORD FERN	#5 CONT.	30" O.C.	
	SARCOCOCCA CONFUSA	SWEET BOX	#5 CONT.	30" O.C.	
	SKIMMIA JAPONICA RUBELLA	JAPANESE SKIMMIA	#5 CONT.	30" O.C.	
GROUNDCOVERS					
	PACHYSANDRA TERMINALIS	JAPANESE SPURGE	#1 CONT.	12" O.C.	

SYMBOL	LATIN NAME	COMMON NAME	CONT./SIZE	SPACING	NOTES
HERBACEOUS PLANTS AND SHRUBS					
	IRIS TENAX	OREGON IRIS	#1 CONT.	12" O.C.	
	JUNCUS PATENS	SPREADING RUSH	#1 CONT.	12" O.C.	
	MAHONIA EURHYMENOCARPA	SOFT CARESS MAHONIA	#5 CONT.	30" O.C.	
	POLYSTICHUM MUNIFOLIUM	WESTERN SWORD FERN	#1 CONT.	24" O.C.	

SYMBOL	LATIN NAME	COMMON NAME	CONT./SIZE	SPACING	NOTES
	IRIS TENAX	OREGON IRIS	#1 CONT.	12" O.C.	
	JUNCUS PATENS	SPREADING RUSH	#1 CONT.	12" O.C.	
	MAHONIA EURHYMENOCARPA	SOFT CARESS MAHONIA	#5 CONT.	30" O.C.	
	POLYSTICHUM MUNIFOLIUM	WESTERN SWORD FERN	#1 CONT.	24" O.C.	

4 PLANTING SCHEDULE
SCALE: NTS

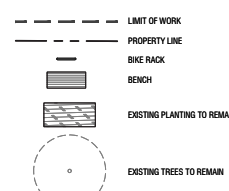

5 LEGEND
SCALE: NTS

- WORK OR ANY DISTURBANCE OUTSIDE THE LIMITS OF WORK SHOWN REQUIRE WRITTEN PERMISSION BY OWNER.
- ASCERTAIN ALL FACTS CONCERNING CONDITIONS TO BE FOUND AT THE LOCATION OF THE PROJECT INCLUDING ALL PHYSICAL CHARACTERISTICS ABOVE AND BELOW THE SURFACE OF THE GROUND AND TO FULLY EXAMINE THE PLANS AND SPECIFICATIONS, BRING ANY DISCREPANCIES IN DIMENSIONING OR LAYOUT TO THE ATTENTION OF THE OWNER'S REP. PRIOR TO BEGINNING WORK. WHERE CONFLICT IS REQUIRED, COST OF PROCEEDING WITHOUT OWNER'S REP. WRITTEN CLARIFICATION AND AUTHORIZATION TO PROCEED SHALL BE AT THE CONTRACTOR'S EXPENSE.
- ATTENTION: OREGON LAW REQUIRES YOU TO FOLLOW RULES ADOPTED BY THE OREGON UTILITY NOTIFICATION CENTER. THESE RULES ARE SET FORTH IN OUR 855-841-0000. YOU MAY OBTAIN COPIES OF THE RULES BY CALLING THE CENTER. NOTE: THE TELEPHONE NUMBER FOR THE OREGON UTILITY NOTIFICATION CENTER IS (503) 225-1000. EXCAVATIONS MUST NOTIFY ALL PERTINENT COMPANIES OR AGENCIES WITH UNDERGROUND UTILITIES IN THE PROJECT AREA AT LEAST 48 BUSINESS DAY HOURS, BUT NOT MORE THAN 10 BUSINESS DAYS PRIOR TO COMMENCING AN EXCAVATION, SO UTILITIES MAY BE ACCURATELY LOCATED.
- LOCATE ALL UNDERGROUND, SURFACE AND OVERHEAD UTILITIES PRIOR TO ANY WORK. CALL FOR LOCATES AND COORDINATE WITH UTILITY SERVICE PROVIDERS.
- TAKE EXTRA CARE IN EXCAVATING AREAS ADJACENT TO EXISTING AND PROPOSED UNDERGROUND UTILITIES. REFERENCE CIVIL AND ELECTRICAL DRAWINGS FOR UTILITY INFORMATION.
- PROTECT EXISTING LANDSCAPE, BENCH MARKS, UTILITIES, SIDEWALKS, DRIVEWAYS AND CURBS FROM EQUIPMENT, VEHICLE TRAFFIC AND GENERAL CONSTRUCTION ACTIVITIES. PROTECT UNDERGROUND IRRIGATION SYSTEM.
- ANY DAMAGE RESULTING FROM THIS WORK MUST BE RESTORED AT THE CONTRACTOR'S OWN EXPENSE.
- "APPROVAL" DOES NOT RELEASE CONTRACTOR FROM RESPONSIBILITY FOR PROVIDING MATERIALS OR METHODOLOGIES AGREED UPON OR AS SPECIFIED.
- VERIFY ALL DIMENSIONS AND CONDITIONS PRIOR TO EACH PHASE OF CONSTRUCTION. NOTIFY OWNERS REPRESENTATIVE PRIOR TO PROCEEDING WITH WORK. WHERE CONFLICT IS REQUIRED, COST OF PROCEEDING WITHOUT OWNER'S REPRESENTATIVE WRITTEN CLARIFICATION AND AUTHORIZATION TO PROCEED SHALL BE AT THE CONTRACTOR'S EXPENSE.

6 GENERAL NOTES
SCALE: NTS

- PROTECT ALL EXISTING TREES INCLUDING TRUNKS, ROOTS AND FOLIAGE NOT INDICATED FOR REMOVAL.
- MEET THE LATEST VERSION OF THE AMERICAN STANDARD FOR NURSERY STOCK ANSI Z66.1.
- VERIFY PLANT COUNTS AND AREAS PRIOR TO SUBMITTING UNIT PRICE BIDS AND ORDERING. THE AGENCY MUST APPROVE ANY NECESSARY SUBSTITUTIONS.
- DO NOT INSTALL PLANTS UNTIL SOIL HAS BEEN PREPARED AND AMENDED TO THE APPROVAL OF THE OWNER'S REP.
- RECEIVE WRITTEN APPROVAL FROM THE AGENCY ACCEPTING ROUGH GRADING AND FINE GRADING BEFORE PLANTING AND SEEDING OPERATIONS COMMENCE.
- LOCATE PLANTS AS SHOWN ON THE PLANS AND AS SHOWN IN THE PLANTING LEGEND. MEASURED CENTER TO CENTER. PLANT LOCATIONS MAY BE ADJUSTED BY THE OWNER'S REP. TO MEET FIELD CONDITIONS SUCH AS SET-BACKS FROM CURBS, SIDEWALKS, PAVES, CHECK DAMS AND UTILITIES.
- THOROUGHLY WATER-IN ALL PLANTS WITHIN 6 HOURS OF PLANTING.
- APPLY SPECIFIED MULCH AROUND PLANTS WITHIN TWO DAYS OF INSTALLING PLANTS.
- DO NOT LIMB-UP TREES, SHEAR OR PRUNE PLANTS UNLESS UNDER THE DIRECTION OF LANDSCAPE ARCHITECT.
- TO CALCULATE THE QUANTITY OF PLANTS PER AREA, USE THE FOLLOWING SPACING MULTIPLIERS:

TRIANGULAR SPACING	0"	12"	15"	18"	24"	30"	36"	48"
SQUARE FT MULTIPLIER	2.027	1.156	0.513	0.322	0.288	0.184	0.128	0.072

7 PLANTING NOTES
SCALE: NTS

PLANTING PLAN

HACKER Mayer/Reed



Cercidiphyllum japonicum 'Rotfuchs'
Red Fox Katsura



Tsuga mertensiana
Mountain Hemlock

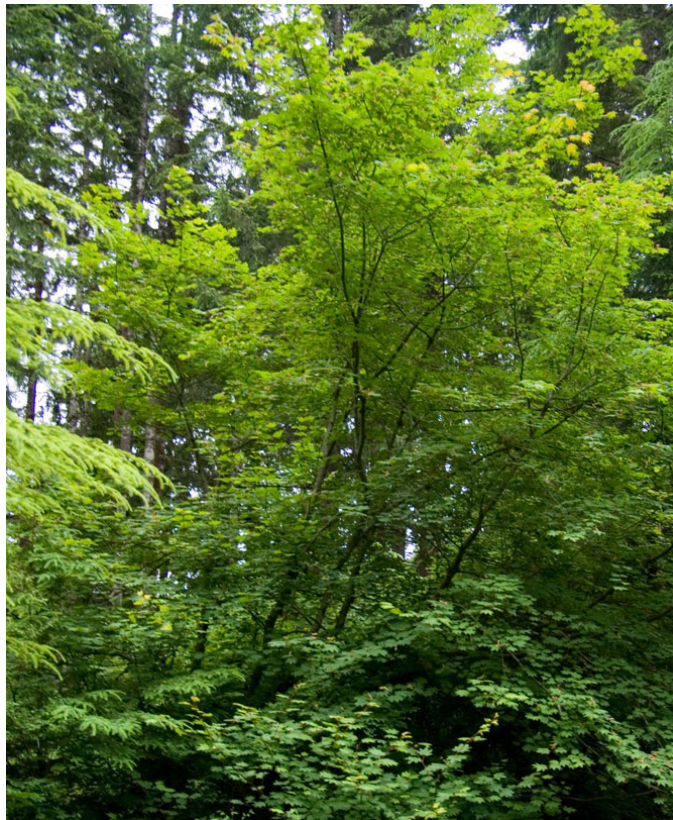

Acer circinatum
Vine Maple



Thuja plicata 'Hogan'
Hogan's Red Cedar



Mahonia eurybracteata 'Soft Caress'
Soft Caress Mahonia



Sarcococca confusa
Sweet Box



Skimmia japonica 'Rubella'
Rubella Japanese Skimmia



Polygonatum odoratum 'Variegatum'
Solomon's Seal



Juncus patens
Spreading Rush



Polystichum munitum
Western Sword Fern

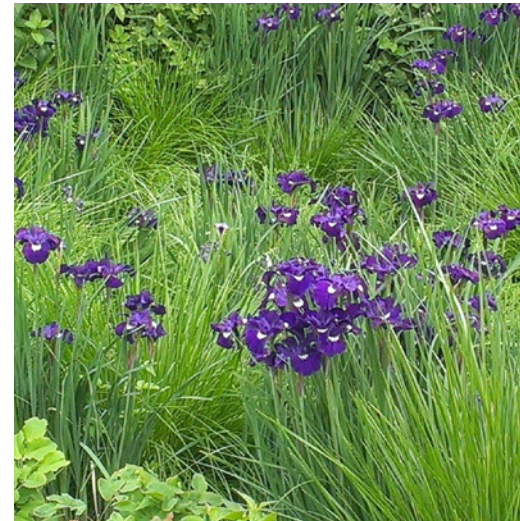

Iris tenax
Oregon Iris



Pachysandra terminalis
Japanese Spurge

PLANT PALETTE



CAMPUS MAP

PUBLIC ART - TOM HARDY RELOCATION

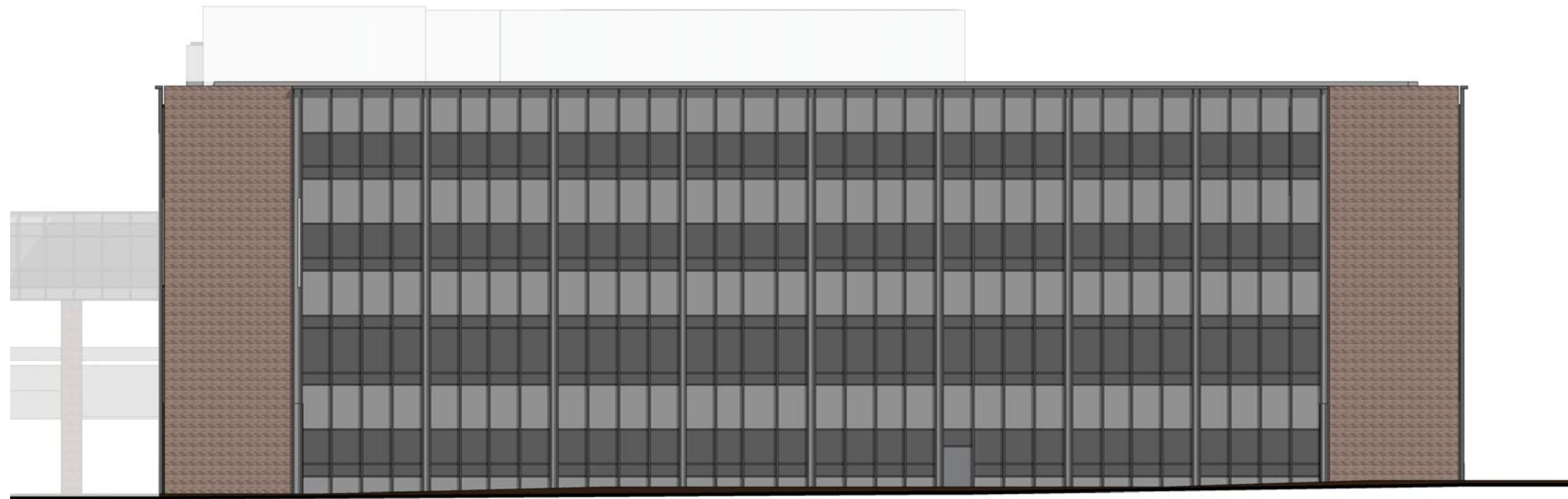

01 WEST ELEVATION (EXISTING)
SCALE : 3/64" = 1'-0"

01 ▶

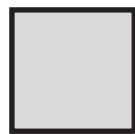

BUILDING ELEVATION - WEST (EXISTING)

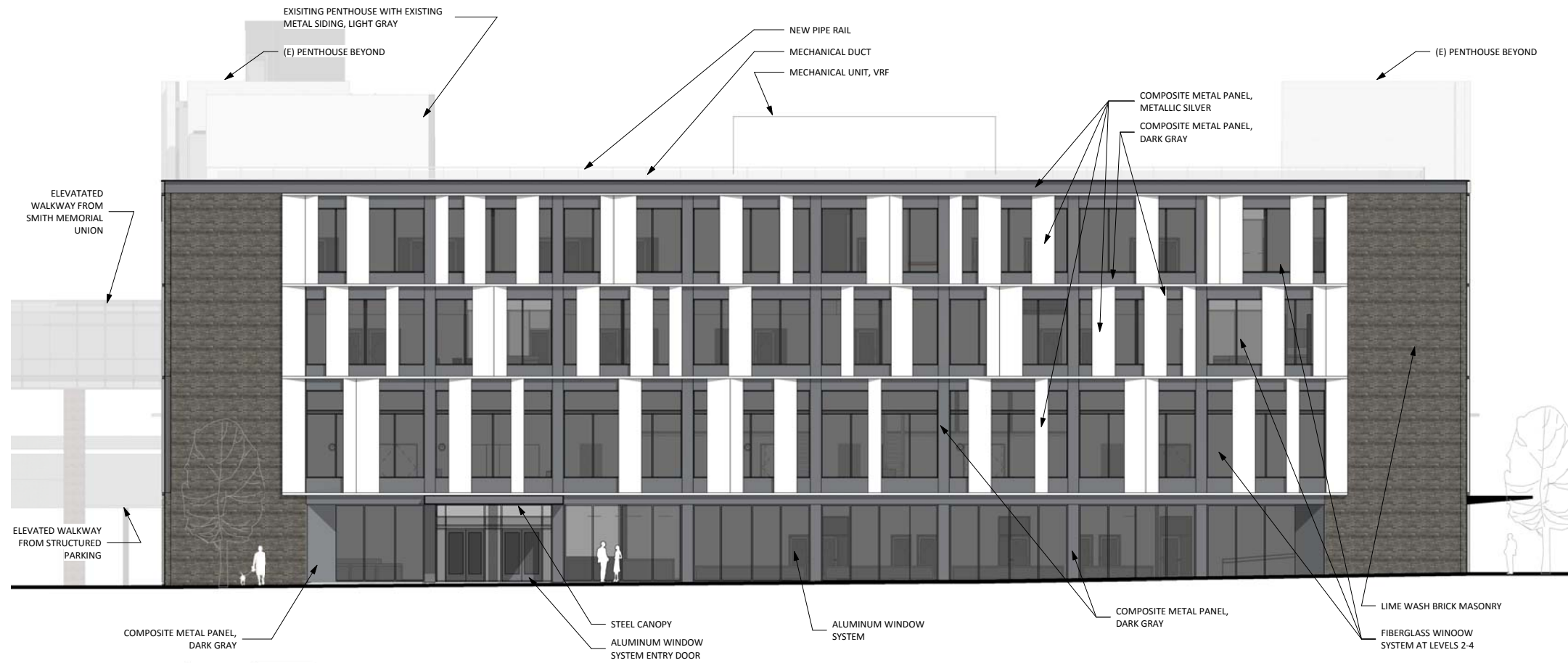

01 WEST ELEVATION
SCALE : 3/64" = 1'-0"

01



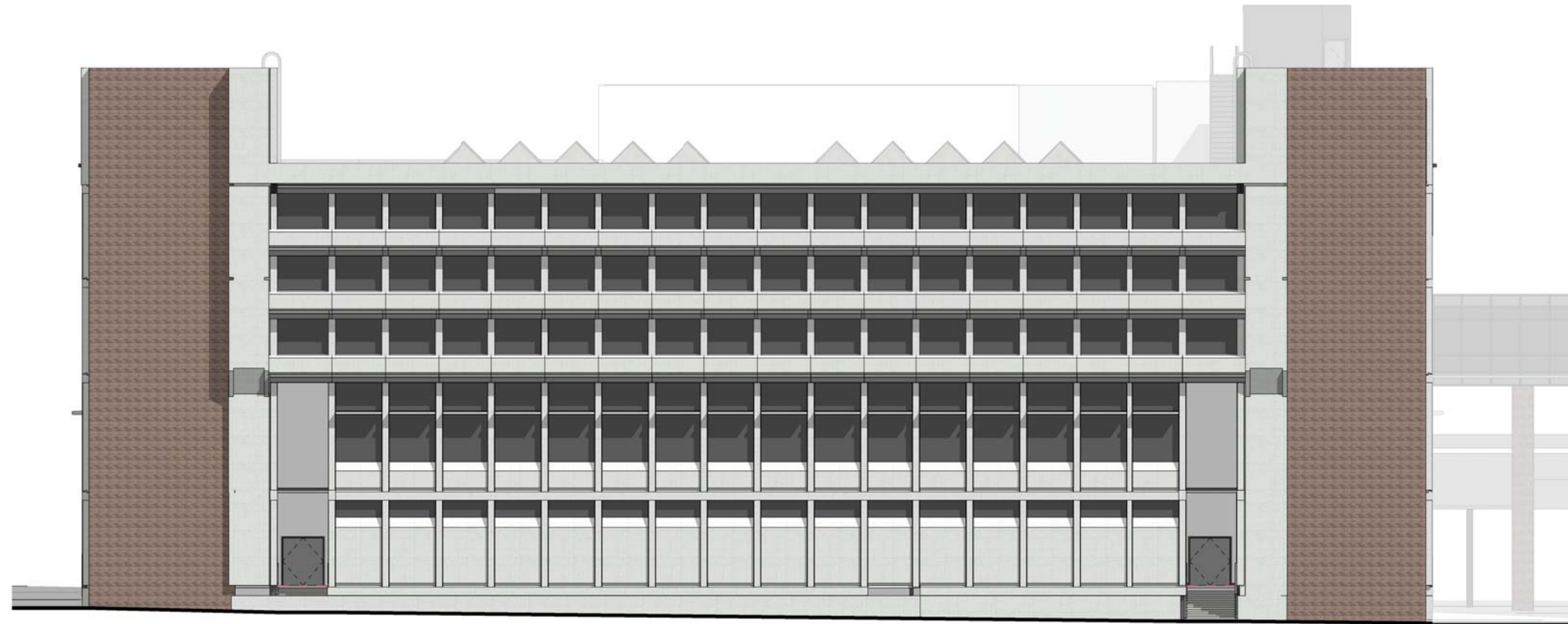

01 EAST ELEVATION (EXISTING)
SCALE : 3/64" = 1'-0"

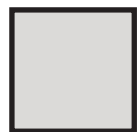

◀ 01

BUILDING ELEVATION - EAST (EXISTING)

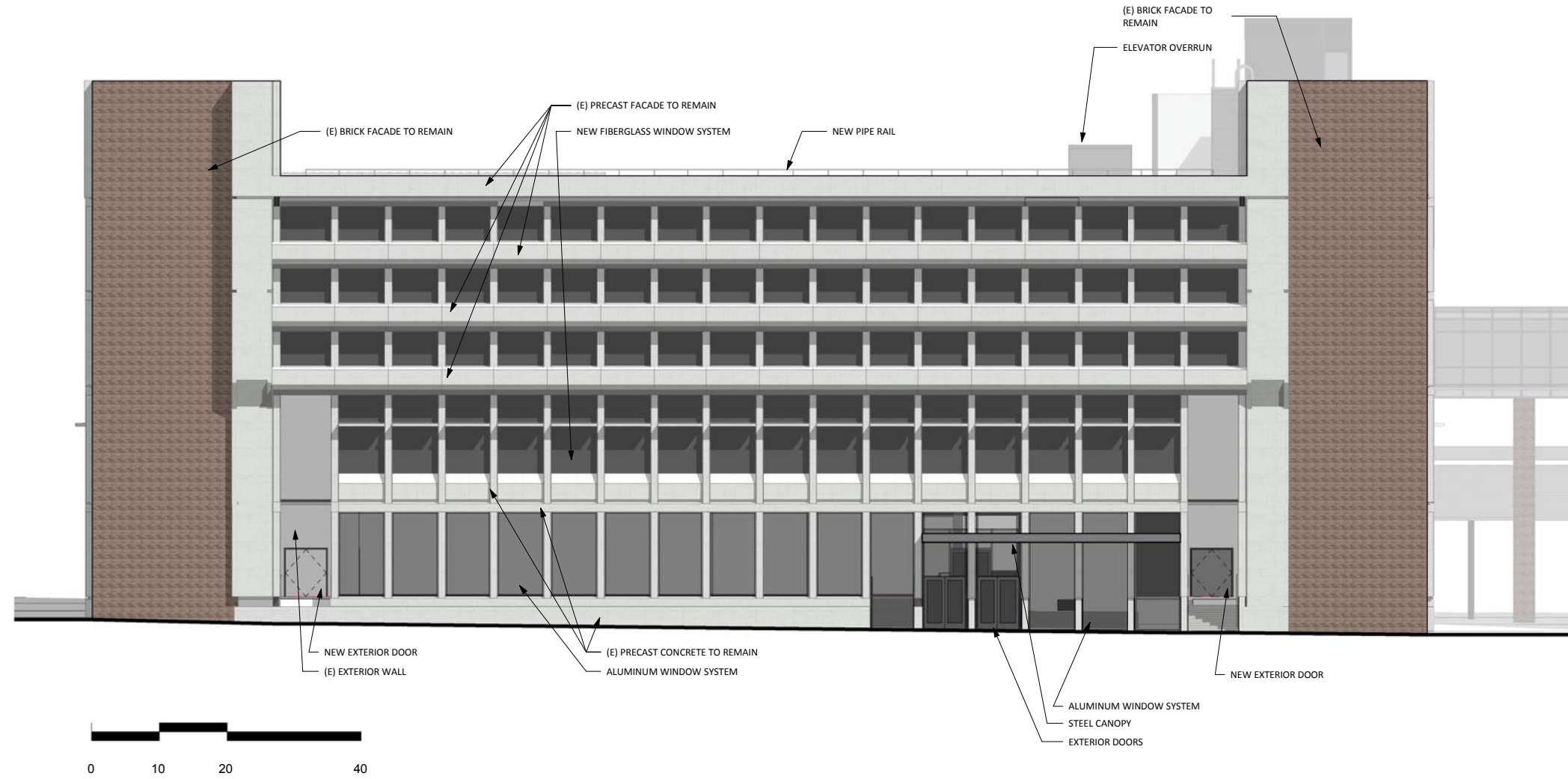

01 EAST ELEVATION
SCALE : 3/64" = 1'-0"





01

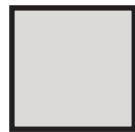

01 NORTH ELEVATION
SCALE : 3/64" = 1'-0"

BUILDING ELEVATION - NORTH (EXISTING)

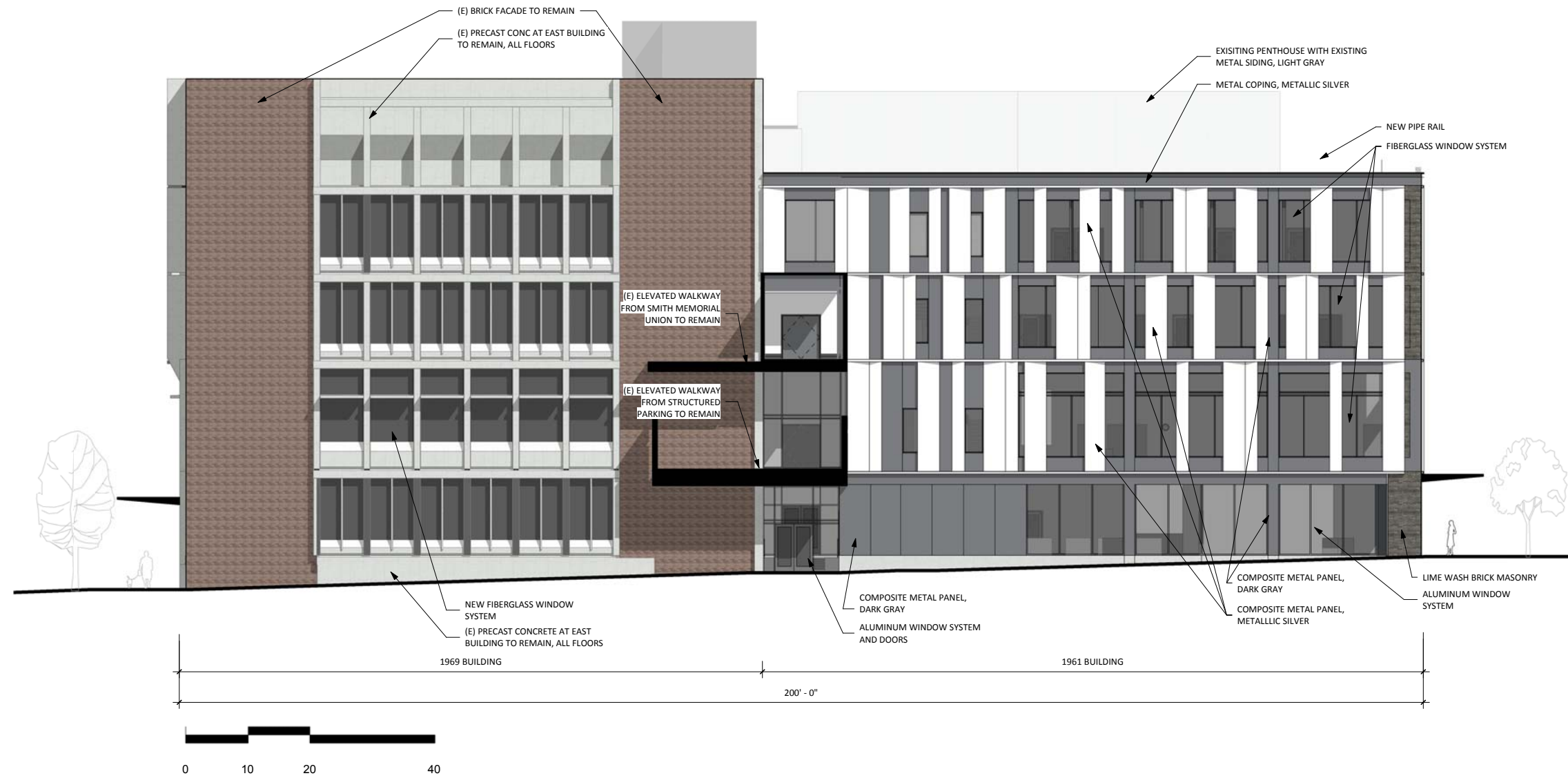

01 NORTH ELEVATION
 SCALE : 3/64" = 1'-0"



01 SOUTH ELEVATION (EXISTING)
SCALE : 3/64" = 1'-0"

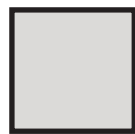

01

BUILDING ELEVATION - SOUTH (EXISTING)

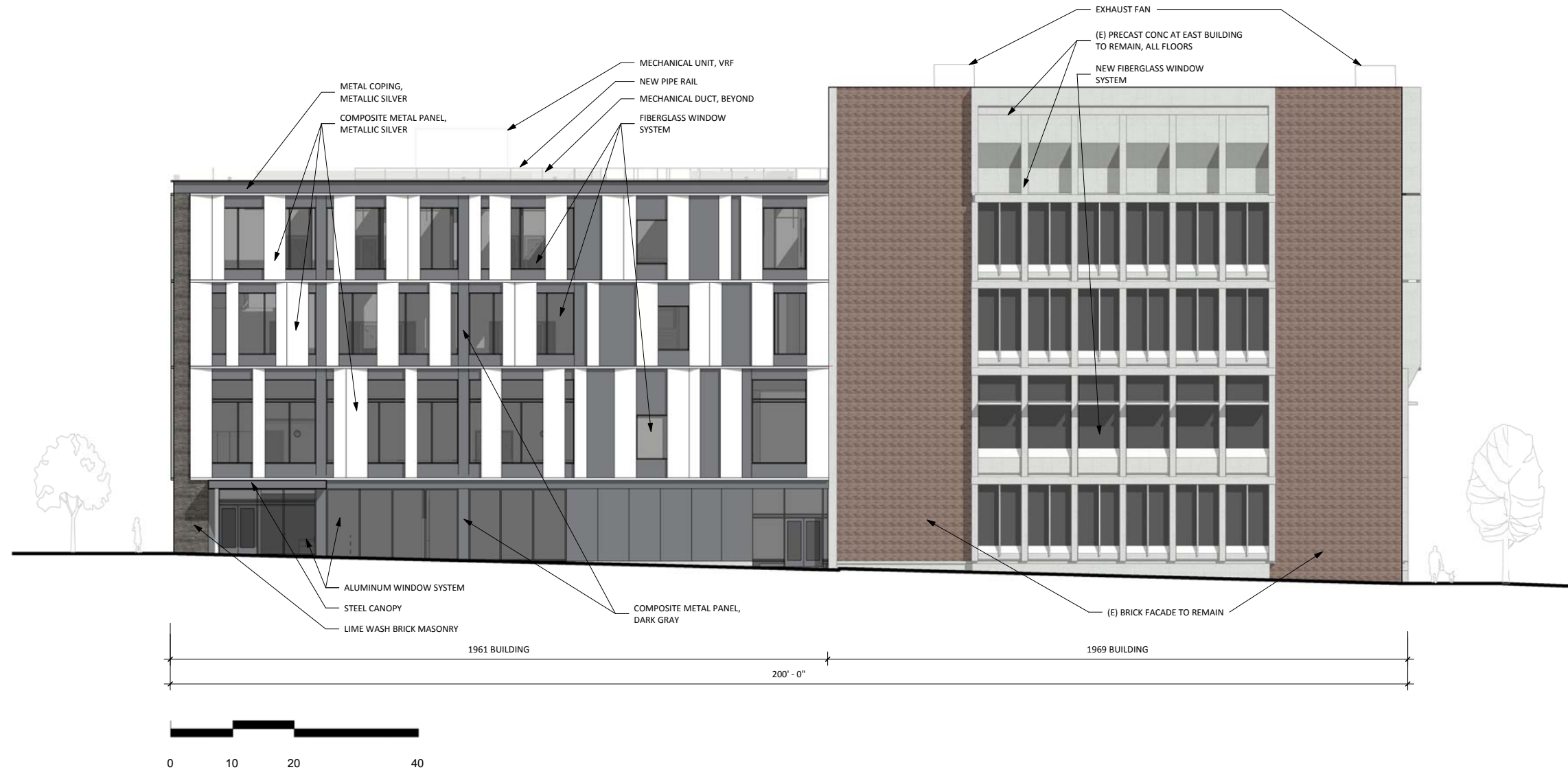

01 SOUTH ELEVATION
 SCALE : 3/64" = 1'-0"



01

BUILDING ELEVATION - SOUTH

HACKER



SW PARK AVE FACING NORTH



SW PARK AVE FACING SOUTHEAST



SW PARK AVE FACING SOUTH



SW BROADWAY FACING NORTH



SW HALL ST FACING NORTHWEST



SW HALL ST FACING WEST



SW HARRISON ST FACING WEST



SW HARRISON ST FACING SOUTHWEST



SW BROADWAY FACING SOUTH

HACKER



SW HARRISON ST PEDESTRIAN BRIDGES FACING EAST



SW BROADWAY PEDESTRIAN BRIDGE FACING EAST



SW HARRISON ST PEDESTRIAN BRIDGES FACING WEST



NEUBERGER HALL EAST FACADE GROUND FLOOR



NEUBERGER HALL NORTHWEST FACADE DETAIL

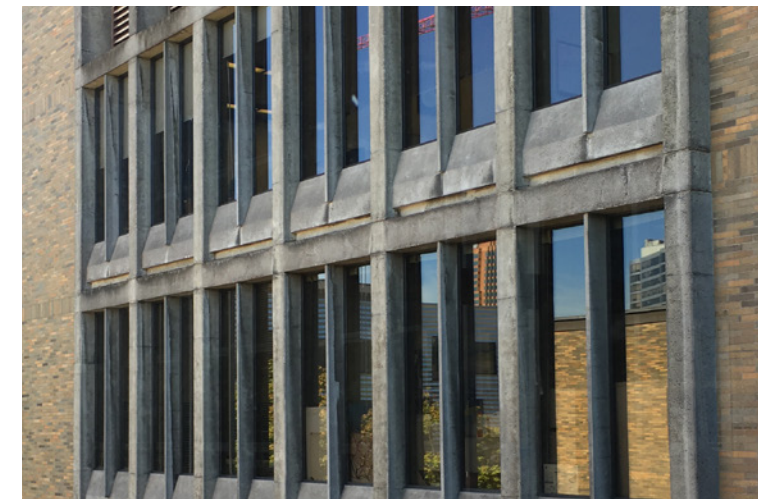

NEUBERGER HALL EAST FACADE LEVEL 3-4



SW BROADWAY EXIT CORRIDOR

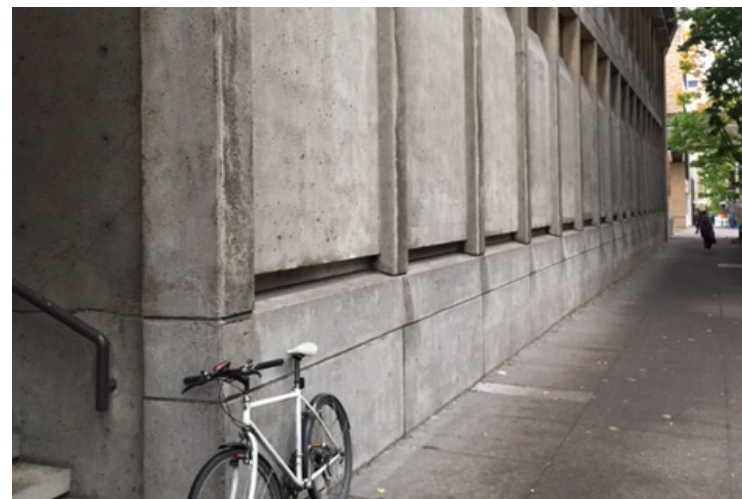

ROW AT SW BROADWAY FACING NORTH



NEUBERGER HALL SOUTH BUILDING ENTRY